

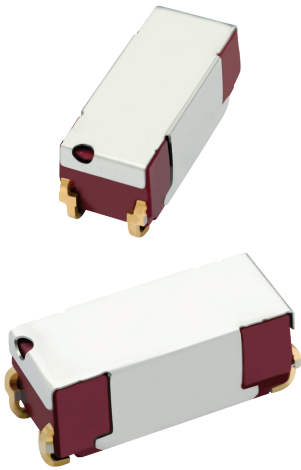

THE DATASHEET OF
9913-05-20TR



9913 SURFACE MOUNT REED RELAYS



9913 Series Surface Mount Reed Relays

Ideally suited to the needs of Automated Test Equipment, Instrumentation and Telecommunications designers, Coto's 9913 Series is an ultraminiature Surface Mount Reed Relay with the smallest footprint available in the market. The external Magnetic Shield reduces interaction between parts in high density boards. Small size allows for high density packaging which makes these relays ideal where high pin count and high performance are needed.

9913 Series Features

- ▶ Available in a compact J Bend SMD package
- ▶ Tape and Reel packaging available
- ▶ High reliability, hermetically sealed contacts for long life
- ▶ High Insulation Resistance - $10^{11} \Omega$ minimum
- ▶ External Magnetic Shield
- ▶ RoHS compliant

DIMENSIONS

in Inches (Millimeters)

Model 9913

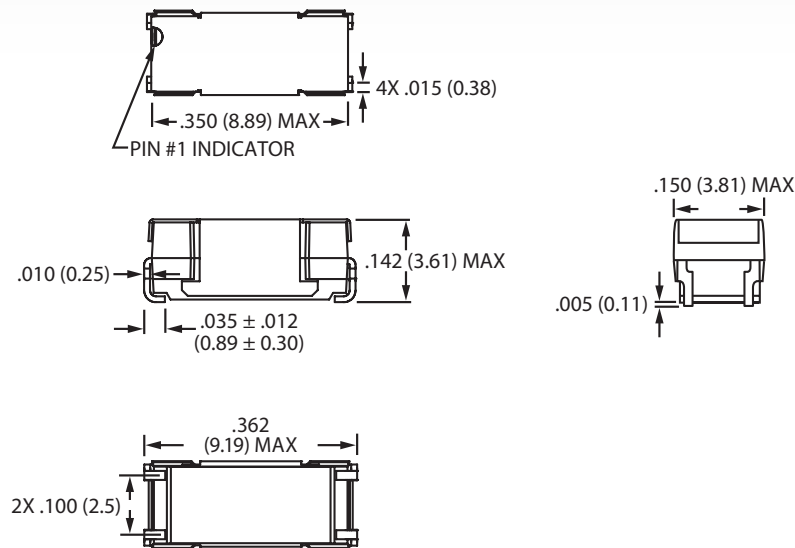

Ordering Information

Part Number	9913-XX-XX	Lead Style
Coil Voltage		20=J-Lead
05=5 volts		

01152015

tel: (401) 943.2686 | fax: (401) 942.0920

MODEL NUMBER			9913		
Parameters	Test Conditions	Units	1 Form A		
COIL SPECS.			MIN	NOM	MAX
Nom. Coil Voltage		VDC	-	5.0	6.0
Coil Resistance	+/- 10%, 25° C	Ω	180	200	220
Operate Voltage	Must Operate by	VDC - Max.	-	-	3.8
Release Voltage	Must Release by	VDC - Min.	0.4	-	-
CONTACT RATINGS					
Switching Voltage	Max DC/Peak AC Resist.	Volts	-	-	100
Switching Current	Max DC/Peak AC Resist.	Amps	-	-	0.25
Carry Current	Max DC/Peak AC Resist.	Amps	-	-	0.5
Contact Rating, Switching	Max DC/Peak AC Resist.	Watts	-	-	5
Life Expectancy-Signal Load	1 V, 10mA	Ops.	-	500 x 10 ⁶	-
Static Contact Resistance	50mV, 10mA	Ω	-	-	0.150
Dynamic Contact Resistance	0.5V, 50mA at 100 Hz, 1.5 msec	Ω	-	-	0.150
Insulation Resistance - All isolated points	@100 VDC 25° , 40% RH	Ω	10 ¹¹	-	-
RELAY SPECIFICATIONS					
Capacitance - Across Open Contacts	-	pF	-	0.2	-
Capacitance - Open Contact to Coil	-	pF	-	0.5	-
Dielectric Strength (minimum)	Between Contacts	VDC/peak AC	150	-	-
Operate Time - including bounce	At Nominal Coil Voltage, 30 Hz Square Wave	msec.	-	0.25	0.3
Release Time - Zener Diode Suppression		msec.	-	-	0.05

Top View:
Dot stamped on top of relay refers to pin #1 location

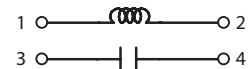

RECOMMENDED PAD LAYOUT

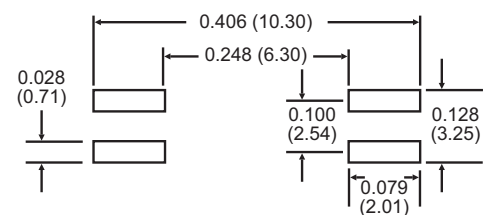

Notes:

- All parameters specified per EIA/NARM Standards for dry reed relays, no #RS-421 & RS-436 unless otherwise noted, all parameters specified @ 25°C & 40% RH.
- Vibration: 20G's to 2000 Hz Shock: 50G's
- All parameters measured at 25°C unless otherwise specified.
- Surface mount component processing temperature: 500°F / 260°C Max 1 minute dwell time.

Environmental Ratings:

Storage Temp: -35°C to +100°C; Operating Temp: -20°C to +85°C

Looking for pricing, stock, or lifecycle information?

Click below to explore more details on WIN SOURCE:

 [View 9913-05-20TR](#) on WIN SOURCE

 [Coto Technology](#) Information

Optimize Your Supply Chain with WIN SOURCE Solutions

-  Global Sourcing Solution
-  Obsolete Management
-  Cost Control Management
-  Shortage Management
-  Alternative Solution
-  Excess Inventory Management