



**THE DATASHEET OF
BQ25172DSGR**



BQ25172: 800-mA Linear Battery Charger for 1- to 6-Cell NiMH Batteries

1 Features

- Input voltage up to 30-V tolerant
- Automatic Sleep Mode for low power consumption
 - 350-nA battery leakage current
 - 85- μ A input leakage current when charge disabled
- Supports 1- to 6-cell NiMH with intermittent-charging
- External resistor programmable operation
 - VSET to set NiMH series cell-count from 1s to 6s
 - ISET to set charge current from 10 mA to 800 mA
 - TMR to set charge safety timer duration from 4 hr to 22 hr
- High accuracy
 - $\pm 0.5\%$ charge voltage accuracy
 - $\pm 10\%$ charge current accuracy
- Charging features
 - NTC thermistor input to monitor battery temperature
 - Cold and hot temperature charging disabled
 - V_{OUT_OVP} reduced at cool temperatures
 - TS pin for charging function control
 - Open-drain output for status and fault indication
- Integrated fault protection
 - 18-V IN overvoltage protection
 - VSET based OUT overvoltage protection
 - 1000-mA overcurrent protection
 - 125°C thermal regulation; 150°C thermal shutdown protection
 - OUT short-circuit protection
 - VSET, ISET, TMR pins short/open protection

2 Applications

- [Fleet management, asset tracking](#)
- [Gas detector](#)
- [Electronic point of sales \(ePOS\)](#)
- [Beauty and grooming](#)
- [Electric toothbrush](#)
- [Pulse oximeter](#)
- [Blood glucose monitor](#)
- [Infrared thermometer](#)

3 Description

The BQ25172 is an integrated 800-mA linear charger for 1-cell to 6-cell NiMH batteries targeted at industrial and medical applications. The device has a single power output that charges the battery. The system load can be placed in parallel with the battery, as long as the average system load does not prevent the battery from being charged fully within the safety timer duration. When the system load is placed in parallel with the battery, the charge current is shared between the system and the battery.

The device charges NiMH cells in constant current mode only and terminates the charge cycle when the programmable timer expires or the battery voltage exceeds the V_{OUT_OVP} threshold. In all charge phases, an internal control loop monitors the IC junction temperature and reduces the charge current if an internal temperature threshold T_{REG} is exceeded.

The charger power stage and charge current sense functions are fully integrated. The charger function has high accuracy current, charge status display, and timer-based charge termination. The series cell-count, charge current, and charge timer are programmable through external resistors. Intermittent charging allows a NiMH battery to automatically recharge for a reduced timer duration once its voltage falls below the recharge threshold.

Device Information

| PART NUMBER | PACKAGE ⁽¹⁾ | BODY SIZE (NOM) |
|-------------|------------------------|-----------------|
| BQ25172 | WSON (8) | 2.0 mm x 2.0 mm |

- (1) For all available packages, see the orderable addendum at the end of the data sheet.

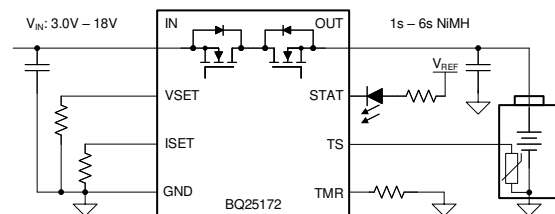

Simplified Schematic



Table of Contents

| | | | |
|------------------------------------------------|----|------------------------------------------------------------------|----|
| 1 Features | 1 | 7.4 Device Functional Modes..... | 16 |
| 2 Applications | 1 | 8 Application and Implementation | 17 |
| 3 Description | 1 | 8.1 Application Information..... | 17 |
| 4 Revision History | 2 | 8.2 Typical Applications..... | 17 |
| 5 Pin Configuration and Functions | 3 | 9 Power Supply Recommendations | 20 |
| 6 Specifications | 4 | 10 Layout | 20 |
| 6.1 Absolute Maximum Ratings..... | 4 | 10.1 Layout Guidelines..... | 20 |
| 6.2 ESD Ratings..... | 4 | 10.2 Layout Example..... | 20 |
| 6.3 Recommended Operating Conditions..... | 4 | 11 Device and Documentation Support | 21 |
| 6.4 Thermal Information..... | 5 | 11.1 Device Support..... | 21 |
| 6.5 Electrical Characteristics..... | 6 | 11.2 Receiving Notification of Documentation Updates.. | 21 |
| 6.6 Timing Requirements..... | 7 | 11.3 Support Resources..... | 21 |
| 6.7 Typical Characteristics..... | 8 | 11.4 Trademarks..... | 21 |
| 7 Detailed Description | 9 | 11.5 Electrostatic Discharge Caution..... | 21 |
| 7.1 Overview..... | 9 | 11.6 Glossary..... | 21 |
| 7.2 Functional Block Diagram..... | 10 | 12 Mechanical, Packaging, and Orderable Information | 22 |
| 7.3 Feature Description..... | 11 | | |

4 Revision History

NOTE: Page numbers for previous revisions may differ from page numbers in the current version.

| DATE | REVISION | NOTES |
|-----------|----------|-----------------|
| June 2022 | * | Initial Release |

5 Pin Configuration and Functions

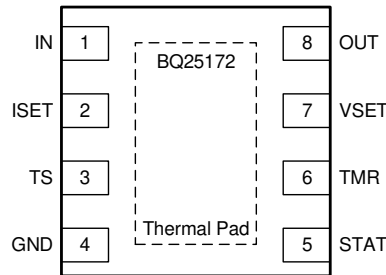

Figure 5-1. DSG Package WSON 8-Pin Top View

Table 5-1. Pin Functions

| PIN | | I/O | DESCRIPTION |
|-------------|--------|-----|------------------------------------------------------------------------------------------------------------------------------------------------------------------------------------------------------------------------------------------------------------------------------------------------------------------------------------------------------------------------------------------------------------|
| NAME | NUMBER | | |
| IN | 1 | P | Input power, connected to external DC supply. Bypass IN with a $\geq 1\text{-}\mu\text{F}$ capacitor to GND, placed close to the IC. |
| ISET | 2 | I | Programs the device charge current. External resistor from ISET to GND defines charge current value. Expected range is 30 k Ω (10 mA) to 375 Ω (800 mA). $I_{CHG} = K_{ISET} / R_{ISET}$. |
| TS | 3 | I | Temperature qualification voltage input. Connect a negative temperature coefficient (NTC) thermistor directly from TS to GND (AT103-2 recommended). Charge suspends when the TS pin voltage is out of range. V_{OUT_OVP} is reduced in cool region. If TS function is not needed, connect an external 10-k Ω resistor from this pin to GND. Pulling $V_{TS} < V_{TS_ENZ}$ disables the charger. |
| GND | 4 | – | Ground pin |
| STAT | 5 | O | Open drain charge status indication output. Connect to the pullup rail via a 10-k Ω resistor. LOW indicates charge in progress. HIGH indicates charge complete or charge disabled. When a fault condition is detected, the STAT pin blinks at 1 Hz. |
| TMR | 6 | I | Connect to a pulldown resistor to program charge safety timer duration. Valid resistor range is 3.6 k Ω to 36 k Ω . Refer to Section 7.3.1.2 . |
| VSET | 7 | I | Programs the number of series NiMH cells. Valid resistor range is 3.6 k Ω to 62 k Ω . Recommend using a $\pm 1\%$ tolerance resistor with < 200 ppm/ $^{\circ}\text{C}$ temperature coefficient. Refer to Section 7.3.1.3 . |
| OUT | 8 | P | Battery connection. System load may be connected in parallel to the battery. Bypass OUT with a $\geq 1\text{-}\mu\text{F}$ capacitor to GND, placed close to the IC. |
| Thermal Pad | — | — | Exposed pad beneath the IC for heat dissipation. Solder thermal pad to the board with vias connecting to solid GND plane. |

6 Specifications

6.1 Absolute Maximum Ratings

over operating free-air temperature range (unless otherwise noted)⁽¹⁾

| | | MIN | MAX | UNIT |
|---------------------------------------|---------------------------|------|-----|------|
| Voltage | IN | -0.3 | 30 | V |
| Voltage | OUT | -0.3 | 13 | V |
| Voltage | ISET, STAT, TMR, TS, VSET | -0.3 | 5.5 | V |
| Output Sink Current | STAT | | 5 | mA |
| Junction temperature, T _J | | -40 | 150 | °C |
| Storage temperature, T _{stg} | | -65 | 150 | °C |

- (1) Operation outside the Absolute Maximum Ratings may cause permanent device damage. Absolute maximum ratings do not imply functional operation of the device at these or any other conditions beyond those listed under Recommended Operating Conditions. If briefly operating outside the Recommended Operating Conditions but within the Absolute Maximum Ratings, the device may not sustain damage, but it may not be fully functional. Operating the device in this manner may affect device reliability, functionality, performance, and shorten the device lifetime.

6.2 ESD Ratings

| | | | VALUE | UNIT |
|--------------------|-------------------------|------------------------------------------------------------------------------------------|-------|------|
| V _(ESD) | Electrostatic discharge | Human body model (HBM), per ANSI/ESDA/ JEDEC JS-001, all pins ⁽¹⁾ | ±2500 | V |
| | | Charged device model (CDM), per JEDEC specification JESD22-C101, all pins ⁽²⁾ | ±1500 | |

- (1) JEDEC document JEP155 states that 500-V HBM allows safe manufacturing with a standard ESD control process.
 (2) JEDEC document JEP157 states that 250-V CDM allows safe manufacturing with a standard ESD control process.

6.3 Recommended Operating Conditions

over operating free-air temperature range (unless otherwise noted)

| | | MIN | NOM | MAX | UNIT |
|------------------------------|-----------------------------------------------------|-------|-----|------|--------|
| V _{IN} | Input voltage | 3.0 | | 18 | V |
| V _{OUT} | Output voltage | | | 10.5 | V |
| I _{OUT} | Output current | | | 0.8 | A |
| T _J | Junction temperature | -40 | | 125 | °C |
| C _{IN} | IN capacitor | 1 | | | μF |
| C _{OUT} | OUT capacitor | 1 | | | μF |
| R _{TMR} | TMR resistor | 3.6 | | 36 | kΩ |
| R _{VSET} | VSET resistor | 3.6 | | 62 | kΩ |
| R _{TMR_VSET_TOL} | Tolerance for TMR, and VSET resistors | -1 | | 1 | % |
| R _{TMR_VSET_TEMPCO} | Temperature coefficient for TMR, and VSET resistors | | | 200 | ppm/°C |
| R _{ISET} | ISET resistor | 0.375 | | 30 | kΩ |
| R _{TS} | TS thermistor resistor (recommend 103AT-2) | | 10 | | kΩ |

6.4 Thermal Information

| THERMAL METRIC ⁽¹⁾ | | BQ25172 | UNIT |
|-------------------------------|----------------------------------------------------------------|-----------|------|
| | | DSG(WSON) | |
| | | 8 PINS | |
| $R_{\theta JA}$ | Junction-to-ambient thermal resistance (JEDEC ⁽¹⁾) | 75.2 | °C/W |
| $R_{\theta JC(top)}$ | Junction-to-case (top) thermal resistance | 93.4 | °C/W |
| $R_{\theta JB}$ | Junction-to-board thermal resistance | 41.8 | °C/W |
| Ψ_{JT} | Junction-to-top characterization parameter | 3.8 | °C/W |
| Ψ_{JB} | Junction-to-board characterization parameter | 41.7 | °C/W |
| $R_{\theta JC(bot)}$ | Junction-to-case (bottom) thermal resistance | 17.0 | °C/W |

- (1) For more information about traditional and new thermal metrics, see the [Semiconductor and IC Package Thermal Metrics](#) application report.

6.5 Electrical Characteristics

3.0V < V_{IN} < 18V and V_{IN} > V_{OUT} + V_{SLEEP}, T_J = -40°C to +125°C, and T_J = 25°C for typical values (unless otherwise noted)

| PARAMETER | | TEST CONDITIONS | MIN | TYP | MAX | UNIT |
|-------------------------------------------------|-----------------------------------------------------------------------------------------|--------------------------------------------------------------------------------------------------------------|------|-------|------|------|
| QUIESCENT CURRENTS | | | | | | |
| I _{Q_OUT} | Quiescent output current (OUT) | OUT= 4.2V, IN floating or IN = 0V - 5V, Charge Disabled, T _J = 25 °C | | 0.350 | 0.6 | μA |
| | | OUT= 4.2V, IN floating or IN = 0V - 5V, Charge Disabled, T _J < 105 °C | | 0.350 | 0.8 | μA |
| I _{Q_OUT} | Quiescent output current (OUT) | OUT = 8.4V, IN floating or IN = 0V - 14V, Charge Disabled, T _J = 25 °C | | 0.8 | 1.2 | μA |
| | | OUT = 8.4V, IN floating or IN = 0V - 14V, Charge Disabled, T _J < 105 °C | | 0.8 | 1.5 | μA |
| I _{SD_IN_TS} | Shutdown input current (IN) with charge disabled via TS pin | IN = 5V, Charge Disabled (V _{TS} < V _{TS_ENZ}), no battery | | 80 | 110 | μA |
| I _{STANDBY_IN} | Standby input current (IN) with charge terminated | IN = 5V, Charge Enabled, charge terminated | | 190 | | μA |
| I _{STANDBY_IN} | Standby input current (IN) with charge terminated | IN = 14V, Charge Enabled, charge terminated | | 230 | | μA |
| I _{Q_IN} | Quiescent input current (IN) | IN = 5V, OUT = 3.8V, Charge Enabled, I _{CHG} = 0A | | 0.45 | 0.6 | mA |
| I _{Q_IN} | Quiescent input current (IN) | IN = 14V, OUT = 7.6V, Charge Enabled, I _{CHG} = 0A | | 0.45 | 0.6 | mA |
| INPUT | | | | | | |
| V _{IN_OP} | IN operating range | | 3.0 | | 18 | V |
| V _{IN_LOWV} | IN voltage to start charging | IN rising | 3.05 | 3.09 | 3.15 | V |
| V _{IN_LOWV} | IN voltage to stop charging | IN falling | 2.80 | 2.95 | 3.10 | V |
| V _{SLEEPZ} | Exit sleep mode threshold | IN rising, V _{IN} - V _{OUT} , OUT = 4V | 95 | 135 | 175 | mV |
| V _{SLEEP} | Sleep mode threshold hysteresis | IN falling, V _{IN} - V _{OUT} , OUT = 4V | | 80 | | mV |
| V _{IN_OV} | VIN overvoltage rising threshold | IN rising | 18.1 | 18.4 | 18.7 | V |
| V _{IN_OVZ} | VIN overvoltage falling threshold | IN falling | | 18.2 | | V |
| CONFIGURATION PINS SHORT/OPEN PROTECTION | | | | | | |
| R _{ISET_SHORT} | Resistor value considered short | R _{ISET} below this at startup, charger does not initiate charge, power cycle or TS toggle to reset | | | 350 | Ω |
| R _{VSET_SHORT} | Resistor value considered short | R _{VSET} below this at startup, charger does not initiate charge, power cycle or toggle to reset | | | 2.8 | kΩ |
| R _{VSET_OPEN} | Resistor value considered open | R _{VSET} above this at startup, charger does not initiate charge, power cycle or toggle to reset | 80 | | | kΩ |
| R _{TMR_SHORT} | Resistor value considered short | R _{TMR} below this at startup, charger latches off, power cycle or TS toggle to reset | | | 2.8 | kΩ |
| R _{TMR_OPEN} | Resistor value considered open | R _{TMR} above this at startup, charger latches off, power cycle or TS toggle to reset | 45 | | | kΩ |
| BATTERY CHARGER | | | | | | |
| I _{CHG_RANGE} | Typical charge current regulation range | | 10 | | 800 | mA |
| K _{ISET} | Charge current setting factor, I _{CHG} = K _{ISET} / R _{ISET} | 10mA < I _{CHG} < 800mA | 270 | 300 | 330 | AΩ |
| I _{CHG_ACC} | Charge current accuracy | R _{ISET} = 375Ω, OUT = 3.8V | 720 | 800 | 880 | mA |
| | | R _{ISET} = 600Ω, OUT = 3.8V | 450 | 500 | 550 | mA |
| | | R _{ISET} = 3.0kΩ, OUT = 3.8V | 90 | 100 | 110 | mA |
| | | R _{ISET} = 30kΩ, OUT = 3.8V | 9 | 10 | 11 | mA |

6.5 Electrical Characteristics (continued)

$3.0V < V_{IN} < 18V$ and $V_{IN} > V_{OUT} + V_{SLEEP}$, $T_J = -40^{\circ}C$ to $+125^{\circ}C$, and $T_J = 25^{\circ}C$ for typical values (unless otherwise noted)

| PARAMETER | | TEST CONDITIONS | MIN | TYP | MAX | UNIT |
|--------------------------------------------------------|-----------------------------------------------------------------------------|-------------------------------------------------|-------|-------|-------|-------------|
| V_{RECHG} | Battery recharge threshold, per cell | OUT falling, VSET configured for 2-cell | 1.305 | 1.330 | 1.355 | V |
| R_{ON} | Charging path FET on-resistance | IOU = 400mA, $T_J = 25^{\circ}C$ | | 845 | 1000 | m Ω |
| | | IOU = 400mA, $T_J = -40 - 125^{\circ}C$ | | 845 | 1450 | m Ω |
| BATTERY CHARGER PROTECTION | | | | | | |
| V_{OUT_OVP} | OUT overvoltage rising threshold, per cell | VOU rising, TS normal | 1.65 | 1.70 | 1.75 | V |
| V_{OUT_OVP} | OUT overvoltage falling threshold, per cell | VOU falling, TS normal | 1.40 | 1.45 | 1.50 | V |
| $V_{OUT_OVP_TSCOO}$ | OUT overvoltage rising threshold, per cell | VOU rising, TS in cool range | 1.45 | 1.50 | 1.55 | V |
| $V_{OUT_OVP_TSCOO}$ | OUT overvoltage falling threshold, per cell | VOU falling, TS in cool range | 1.30 | 1.35 | 1.40 | V |
| I_{OUT_OCP} | Output current limit threshold | IOU rising | 0.9 | 1 | 1.1 | A |
| TEMPERATURE REGULATION AND TEMPERATURE SHUTDOWN | | | | | | |
| T_{REG} | Typical junction temperature regulation | | | 125 | | $^{\circ}C$ |
| T_{SHUT} | Thermal shutdown rising threshold | Temperature increasing | | 150 | | $^{\circ}C$ |
| | Thermal shutdown falling threshold | Temperature decreasing | | 135 | | $^{\circ}C$ |
| BATTERY-PACK NTC MONITOR | | | | | | |
| I_{TS_BIAS} | TS nominal bias current | | 36.5 | 38 | 39.5 | μ A |
| V_{COLD} | Cold temperature threshold | TS pin voltage rising (approx. $0^{\circ}C$) | 0.99 | 1.04 | 1.09 | V |
| | Cold temperature exit threshold | TS pin voltage falling (approx. $4^{\circ}C$) | 0.83 | 0.88 | 0.93 | V |
| V_{COOL} | Cool temperature threshold; V_{OUT_OVP} reduced | TS pin voltage rising (approx. $10^{\circ}C$) | 650 | 680 | 710 | mV |
| | Cool temperature exit threshold; V_{OUT_OVP} returns to normal | TS pin voltage falling (approx. $13^{\circ}C$) | 580 | 610 | 640 | mV |
| V_{HOT} | Hot temperature threshold | TS pin voltage falling (approx. $45^{\circ}C$) | 176 | 188 | 200 | mV |
| | Hot temperature exit threshold | TS pin voltage rising (approx. $40^{\circ}C$) | 208 | 220 | 232 | mV |
| V_{TS_ENZ} | Charge Disable threshold. Crossing this threshold shall shutdown IC | TS pin voltage falling | 40 | 50 | 60 | mV |
| V_{TS_EN} | Charge Enable threshold. Crossing this threshold shall restart IC operation | TS pin voltage rising | 65 | 75 | 85 | mV |
| V_{TS_CLAMP} | TS maximum voltage clamp | TS pin open-circuit (float) | 2.3 | 2.6 | 2.9 | V |
| LOGIC OUTPUT PIN (STAT) | | | | | | |
| V_{OL} | Output low threshold level | Sink current = 5mA | | | 0.4 | V |
| I_{OUT_BIAS} | High-level leakage current | Pull up rail 3.3V | | | 1 | μ A |

6.6 Timing Requirements

| | | MIN | NOM | MAX | UNIT |
|------------------------|-----------------------------------------------------------------------------------|-----|-----|------|---------|
| BATTERY CHARGER | | | | | |
| $t_{TS_DUTY_ON}$ | TS turn-on time during TS duty cycle mode | | 100 | | ms |
| $t_{TS_DUTY_OFF}$ | TS turn-off time during TS duty cycle mode | | 2 | | s |
| $t_{OUT_OCP_DGL}$ | Deglintch time for I_{OUT_OCP} , IOU rising | | 100 | | μ s |
| t_{SAFETY} | Charge safety timer accuracy, $R_{TMR} = 18k\Omega$ | 9.5 | 10 | 10.5 | hr |
| $t_{INTERMITTENT}$ | Commercial Intermittent charge safety timer (NiMH), as percentage of t_{SAFETY} | | 20 | | % |

6.7 Typical Characteristics

$C_{IN} = 1 \mu F$, $C_{OUT} = 1 \mu F$, $V_{IN} = 5 V$, $V_{OUT} = 3.8 V$, Temperature = Ambient (unless otherwise specified)

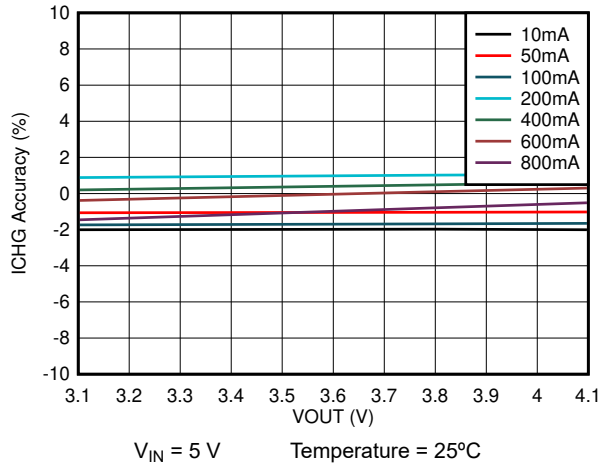

Figure 6-1. ICHG Accuracy vs. Output Voltage

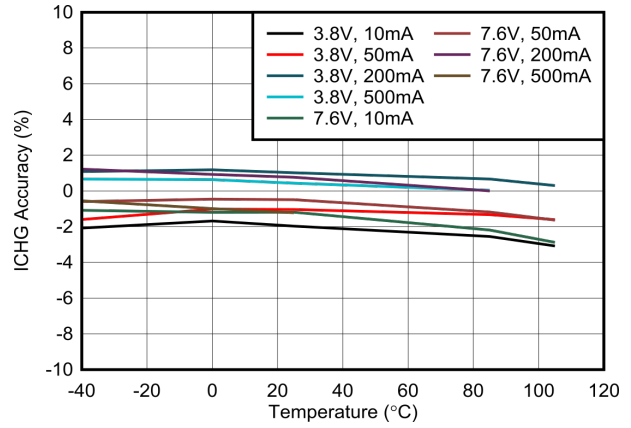

Figure 6-2. ICHG Accuracy vs. Temperature

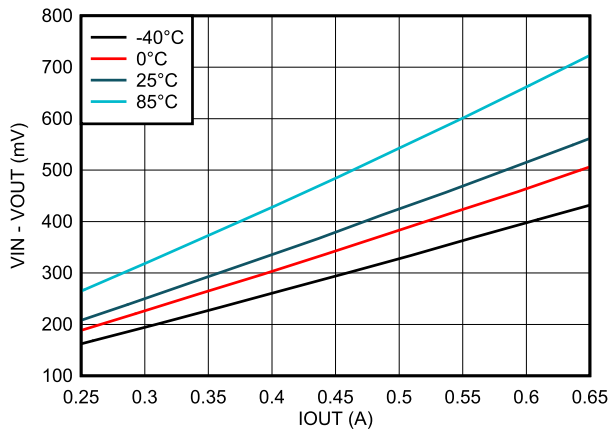

Figure 6-3. Dropout Voltage vs. Output Current

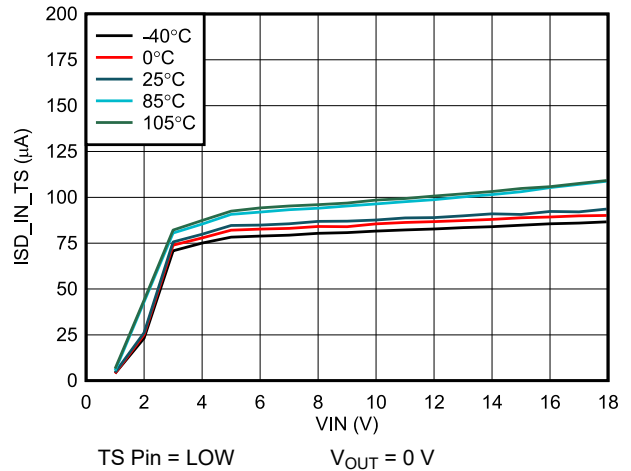

Figure 6-4. Input Shutdown Current vs. Input Voltage

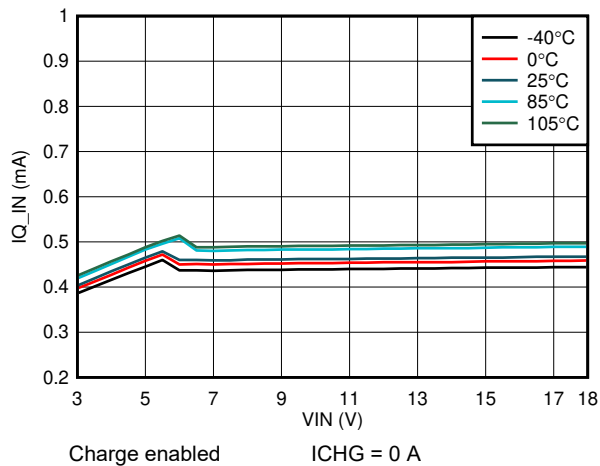

Figure 6-5. Input Quiescent Current vs. Input Voltage

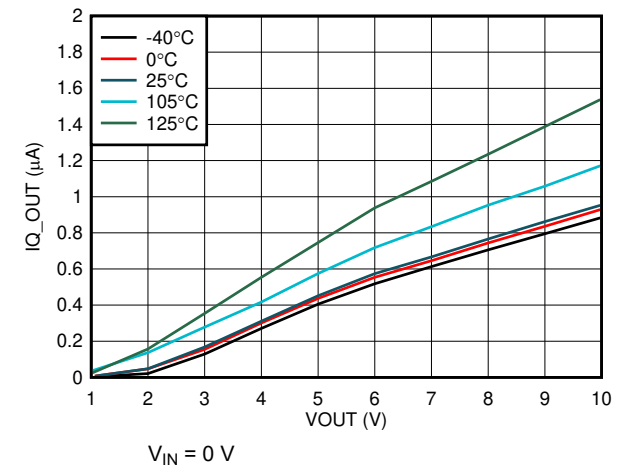

Figure 6-6. Output Quiescent Current vs. Output Voltage

7 Detailed Description

7.1 Overview

The BQ25172 is an integrated 800-mA linear charger for 1-cell to 6-cell NiMH battery applications. The device has a single power output that charges the battery. When the system load is placed in parallel with the battery, the input current is shared between the system and the battery.

The device charges a NiMH battery in constant current mode only and terminates the charge cycle when the programmable timer, t_{SAFETY} , expires or the battery voltage exceeds the $V_{\text{OUT_OVP}}$ threshold. An optional intermittent charging phase can be programmed to automatically recharge the NiMH battery for a reduced timer duration once its voltage falls below V_{RECHG} .

The charger includes flexibility in programming of the charge current, charge safety timer duration, and series cell-count. This charger is designed to work with a standard USB connection or dedicated charging adapter (DC output).

The charger also comes with a full set of safety features: battery temperature monitoring, overvoltage protection, charge safety timer, and configuration pin (VSET, ISET, TMR) short and open protection. Upon application of a valid input power source, the configuration pins are checked for short and open circuits. All of these features and more are described in detail in the following sections.

The charger is designed for a single path from the input to the output to charge the battery. Once the input adapter has been connected, the charge current is applied and the safety timer is started. The charge current is programmed using the ISET pin. The safety timer is programmed by the TMR pin.

Power dissipation in the IC is greatest at high charge currents and low battery voltages. If the IC temperature reaches T_{REG} , the IC enters thermal regulation, slows the timer clock by half, and reduces the charge current as needed to keep the temperature from rising any further.

Further details are described in [Section 7.3](#).

7.2 Functional Block Diagram

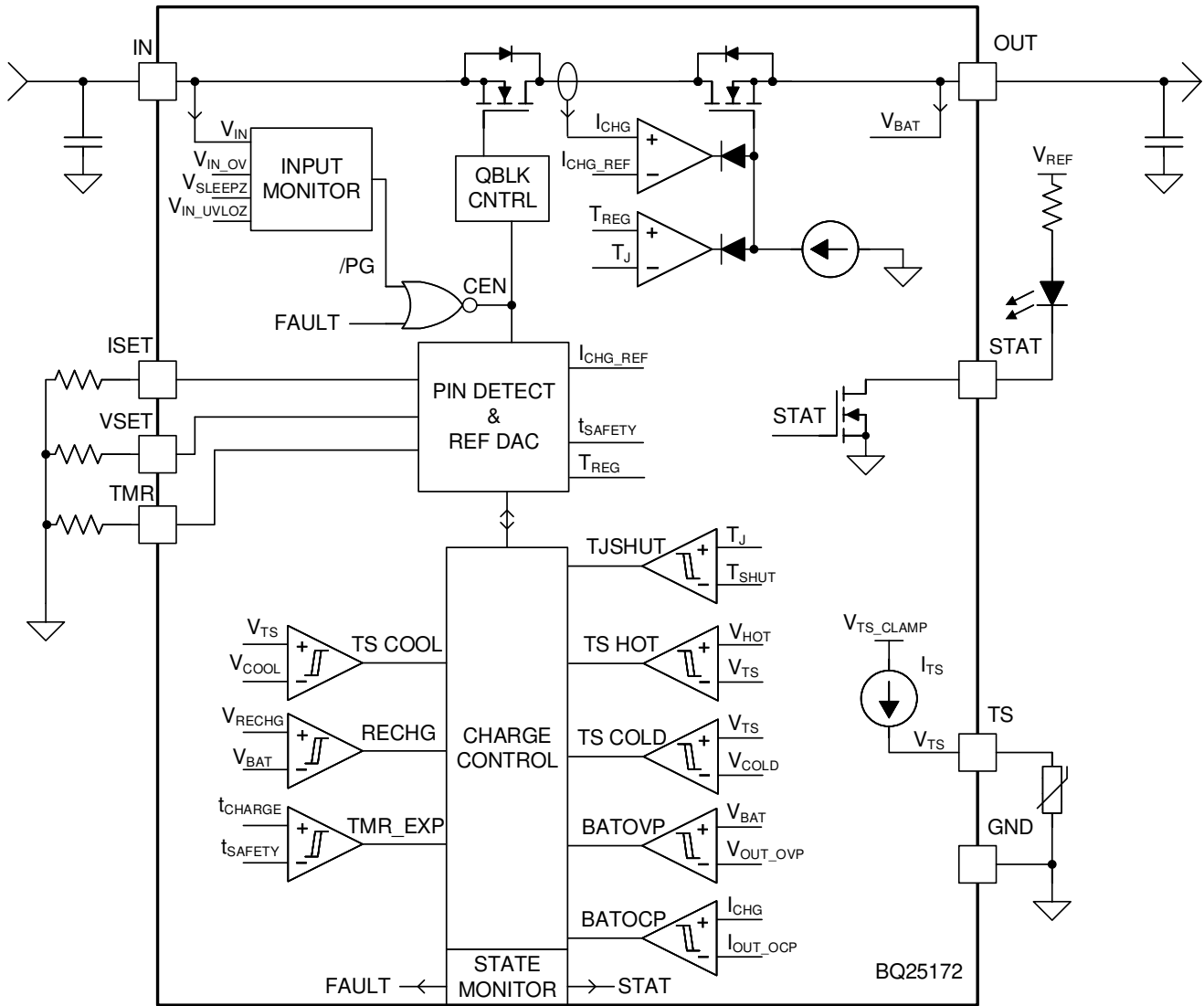

7.3 Feature Description

7.3.1 Device Power Up from Input Source

When an input source is plugged in and charge is enabled ($V_{TS} > V_{TS_EN}$), the device checks the input source voltage to turn on all the bias circuits. It detects and sets the charge current, safety timer length, and series cell-count before the linear regulator is started. The power-up sequence from input source is as listed:

1. ISET pin detection
2. TMR pin detection to select charge timer
3. VSET pin detection to select battery stack configuration
4. Charger power up

7.3.1.1 ISET Pin Detection

After a valid VIN is plugged in and $V_{TS} > V_{TS_EN}$, the device checks the resistor on the ISET pin for a short circuit ($R_{ISET} < R_{ISET_SHORT}$). If a short condition is detected, the charger remains in the FAULT state until the input or TS pin is toggled. If the ISET pin is open-circuit, the charger proceeds through pin detection and starts the charger with no charge current. The ISET pin is monitored while charging and changes in R_{ISET} while the charger is operating immediately translates to changes in charge current.

An external pull-down resistor ($\pm 1\%$ or better is recommended to minimize charge current error) from the ISET pin to GND sets the charge current as:

$$I_{CHG} = \frac{K_{ISET}}{R_{ISET}} \tag{1}$$

where:

- I_{CHG} is the desired charge current
- K_{ISET} is a gain factor found in the electrical characteristics
- R_{ISET} is the pull-down resistor from the ISET pin to GND

For charge currents below 50 mA, an extra RC circuit is recommended on ISET to achieve a more stable current signal. For greater accuracy at lower currents, part of the current-sensing FET is disabled to give better resolution.

7.3.1.2 TMR Pin Detection

The TMR pin is used to program the safety timer using a $\pm 1\%$ pull-down resistor. The available pull-down resistors and corresponding timer lengths are listed in the following table.

Table 7-1. TMR Pin Resistor Value Table

| RESISTOR | CHARGE TIMER (HR) |
|----------|--------------------------|
| > 45 kΩ | No charge (open-circuit) |
| 36 kΩ | 4 hr |
| 27 kΩ | 6 hr |
| 24 kΩ | 8 hr |
| 18 kΩ | 10 hr |
| 15 kΩ | 12 hr |
| 11 kΩ | 14 hr |
| 8.2 kΩ | 16 hr |
| 6.2 kΩ | 18 hr |
| 4.7 kΩ | 20 hr |
| 3.6 kΩ | 22 hr |

Table 7-1. TMR Pin Resistor Value Table (continued)

| RESISTOR | CHARGE TIMER (HR) |
|----------|---------------------------|
| < 3.0 kΩ | No charge (short-circuit) |

If either a short- or open-circuit condition is detected, the charger stops operation and remains in the FAULT state until the input or TS pin is toggled.

Once a value has been detected, it is latched in and the pin is not continuously monitored during operation. A change in this pin is not acknowledged by the IC until the input supply or TS pin is toggled.

7.3.1.3 VSET Pin Detection

The VSET pin is used to program the device cell configuration using a $\pm 1\%$ pulldown resistor. The available pulldown resistors and corresponding cell configurations are listed in the following table.

Table 7-2. VSET Pin Resistor Value Table

| RESISTOR | CELL COUNT |
|---------------|------------------------------|
| > 80 Ω | No charge (open-circuit) |
| 62 kΩ | 1-cell |
| 47 kΩ | 1-cell + intermittent charge |
| 36 kΩ | 2-cell |
| 27 kΩ | 2-cell + intermittent charge |
| 24 kΩ | 3-cell |
| 18 kΩ | 3-cell + intermittent charge |
| 15 kΩ | 4-cell |
| 11 kΩ | 4-cell + intermittent charge |
| 8.2 kΩ | 5-cell |
| 6.2 kΩ | 5-cell + intermittent charge |
| 4.7 kΩ | 6-cell |
| 3.6 kΩ | 6-cell + intermittent charge |
| < 3.0 kΩ | No charge (short-circuit) |

If either a short- or open-circuit condition is detected, the charger stops operation and remains in the FAULT state until the input or TS pin is toggled.

Once a valid resistor value has been detected, the corresponding cell configuration is latched in and the pin is not continuously monitored during operation. A change in this pin is not acknowledged by the IC until the input supply or TS pin is toggled.

7.3.1.4 Charger Power Up

After ISET, TMR, and VSET pin resistor values have been validated, the device proceeds to enable the charger. For more info see [Section 7.3.2.1](#).

7.3.2 Battery Charging Features

When charge is enabled ($V_{TS} > V_{TS_EN}$), the device automatically completes a charging cycle according to the settings on the ISET, TMR, and VSET pins. Charging is terminated when the charge safety timer expires or battery voltage exceeds V_{OUT_OVP} .

7.3.2.1 NiMH Battery Charging Profile

The device charges NiMH batteries in constant current mode only. The charge current programmed by ISET is the only current applied over the charging cycle, as shown in [Figure 7-1](#). The charge termination method for the device is timer-based. The charge safety timer, t_{SAFETY} , sets the charging duration. Programming the charge safety timer is done with a pulldown resistor on the TMR pin.

Intermittent charging is designed to replenish the natural self-discharge of NiMH cells by restarting a short charge cycle (20% of t_{SAFETY}) when the output voltage falls below the V_{RECHG} threshold. If the intermittent charging function is disabled and a full charge cycle has been completed (safety timer expired with V_{OUT} above V_{RECHG}), the device does not start a new charge cycle automatically and requires input supply or TS pin toggle to initiate a new charge cycle.

If battery voltage is above V_{RECHG} at power up, the battery is considered full and the device does not charge. Once the battery voltage falls below V_{RECHG} , the device automatically begins charging. If the intermittent charging function is disabled, a single charge cycle is initiated with the safety timer duration programmed by the TMR pin. If intermittent charging is enabled, an intermittent charge cycle is initiated for 20% of the TMR programmed value.

When the charge timer (full-length or intermittent) expires, the battery voltage is checked again. If the battery voltage is below V_{RECHG} , a fault is reported through the STAT pin and further charging is prevented. If the charge timer expires with V_{OUT} above V_{RECHG} , the STAT pin indicates charge completed. In the case where the TS fault is within the cool threshold, V_{OUT_OVP} is automatically reduced to $V_{OUT_OVP_TSCOOL}$ voltage.

If the charger is in thermal regulation during charging, the actual charging current will be less than the programmed value. Termination by timer is still enabled, but the charging safety timer is counted at half the clock rate. For more information, refer to [Section 7.3.2.2](#).

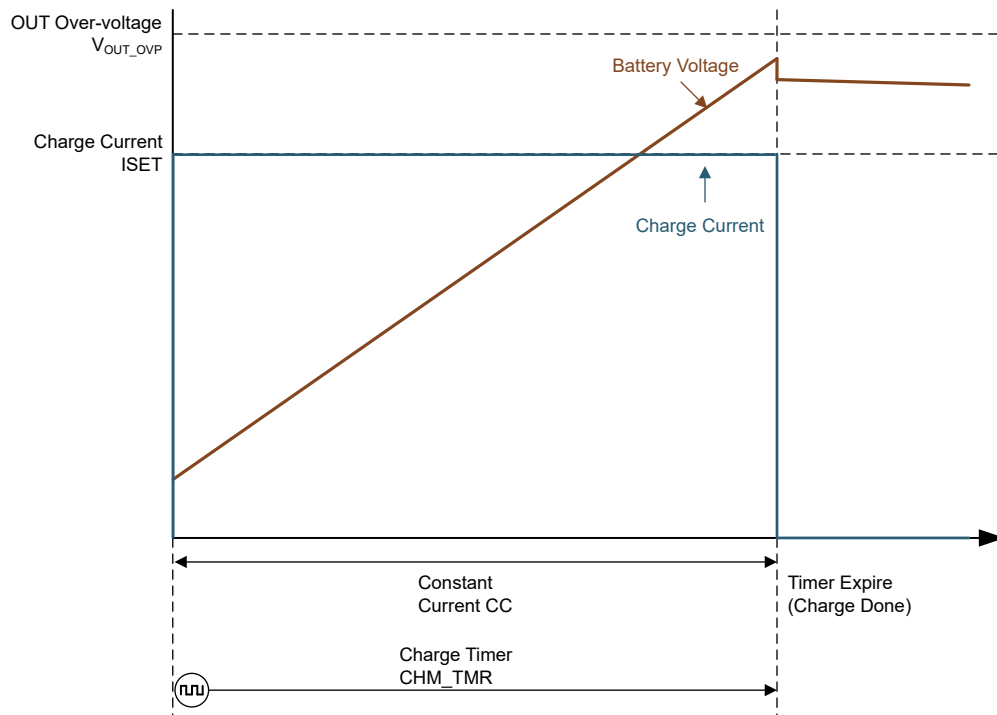

Figure 7-1. NiMH Battery Charging Profile with Intermittent Charging Disabled

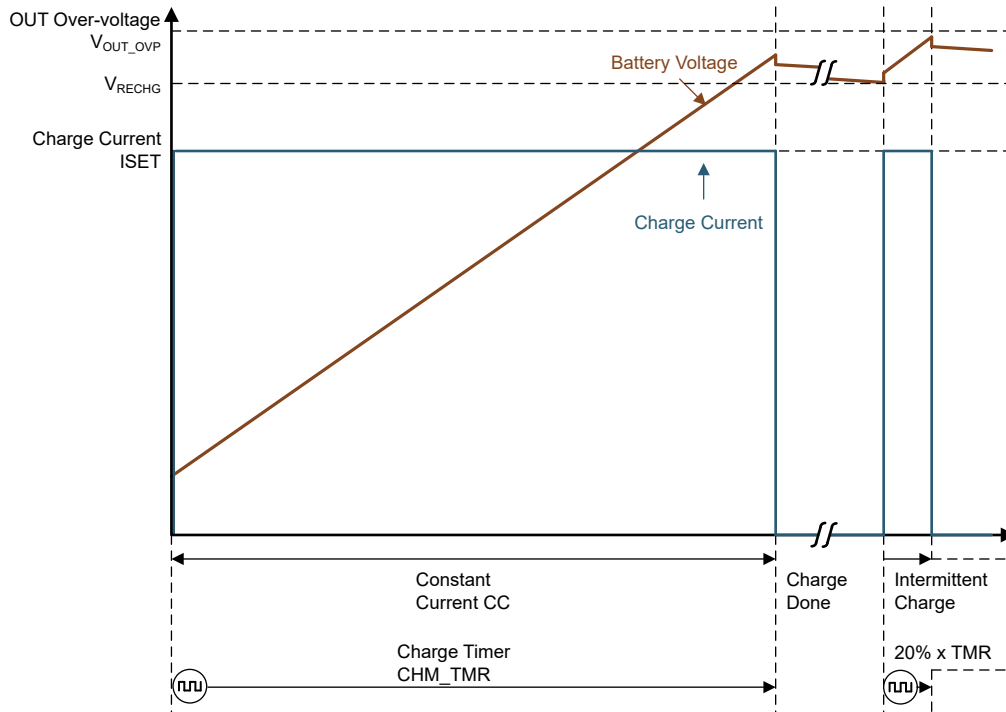

Figure 7-2. NiMH Battery Charging Profile with Intermittent Charging Enabled

7.3.2.2 Charging Safety Timers

The device has built-in safety timers to prevent an extended charging cycle due to abnormal battery conditions. When the safety timer expires, the charge cycle ends.

During thermal regulation, the safety timer counts at half the clock rate as the actual charge current is likely to be below the I_{SET} setting. For example, if the charger is in thermal regulation throughout the whole charging cycle and the safety timer is 10 hours, then the timer will expire in 20 hours.

During faults which disable charging, such as V_{IN} OVP, BAT OVP, TSHUT, or TS faults, the timer is suspended. If the charging cycle is stopped and started again, the timer is reset (toggle of the TS pin restarts the timer).

The safety timer restarts counting when the charging cycle stops and restarts. This can occur as a result of the TS pin being toggled, the battery falling below the recharge threshold, or the input supply being toggled.

7.3.2.3 Battery Cold, Hot Temperature Qualification (TS Pin)

While charging, the device continuously monitors battery temperature by sensing the voltage at the TS pin. A negative temperature coefficient (NTC) thermistor should be connected between the TS and GND pins (recommend: 103AT-2). If temperature sensing is not required in the application, connect a fixed 10-k Ω resistor from the TS pin to GND to allow normal operation. Battery charging is allowed when the TS pin voltage falls between the V_{COLD} and V_{HOT} thresholds (typically 0°C to 45°C).

If the TS pin indicates battery temperature is outside this range, the device stops charging and enters the Standby state. Once battery temperature returns to normal conditions, charging resumes automatically.

In addition to battery temperature sensing, the TS pin can be used to disable the charger at any time by pulling TS voltage below V_{TS_ENZ} . The device disables the charger and consumes $I_{SD_IN_TS}$ from the input supply. In order to minimize quiescent current, the TS current source (I_{TS_BIAS}) is duty-cycled, with an on time of $t_{TS_DUTY_ON}$ and an off time of $t_{TS_DUTY_OFF}$. After the TS pin pulldown is released, the device may take up to $t_{TS_DUTY_OFF}$ to turn I_{TS_BIAS} back on. After the source is turned on, the TS pin voltage goes above V_{TS_EN} and reenables charger operation. The device treats this TS pin toggle as an input supply toggle, triggering a device power up from input source (see Section 7.3.1).

7.3.3 Status Outputs (STAT)

7.3.3.1 Charging Status Indicator (STAT)

The device indicates the charging state on the open-drain STAT pin as listed in the following table. This pin can drive an LED.

Table 7-3. STAT Pin States

| CHARGING STATE | STAT PIN STATE |
|-------------------------------------------------------------------------|----------------|
| Charge completed (TMR_EXP), charger in Sleep mode or charge disabled | High |
| Charge in progress (including intermittent charge active) | Low |
| Fault (VIN OVP, BAT OVP, BAT OCP, or VSET, ISET, TMR pin short or open) | Blink at 1 Hz |

7.3.4 Protection Features

The device closely monitors input and output voltages, as well as internal FET current and temperature for safe linear regulator operation.

7.3.4.1 Input Overvoltage Protection (VIN OVP)

If the voltage at the IN pin exceeds V_{IN_OV} , the device turns off, the safety timer suspends counting, and the device enters Standby mode. Once the IN voltage recovers to a normal level, the charge cycle and the safety timer automatically resume operation.

7.3.4.2 Output Overvoltage Protection (BAT OVP)

If the voltage at the OUT pin exceeds V_{OUT_OVP} , the device immediately stops charging, the safety timer suspends counting, and the device enters Standby mode. Once the OUT voltage recovers to a normal level, the charge cycle and the safety timer resume operation.

7.3.4.3 Output Overcurrent Protection (BAT OCP)

During normal operation, the OUT current should be regulated to the ISET programmed value. However, if a short circuit occurs on the ISET pin, the OUT current may rise to an unintended level. If the current at the OUT pin exceeds I_{OUT_OCP} , the device turns off after a deglitch, $t_{OUT_OCP_DGL}$, the safety timer resets the count, and the device remains latched off. An input supply or pin toggle is required to restart operation.

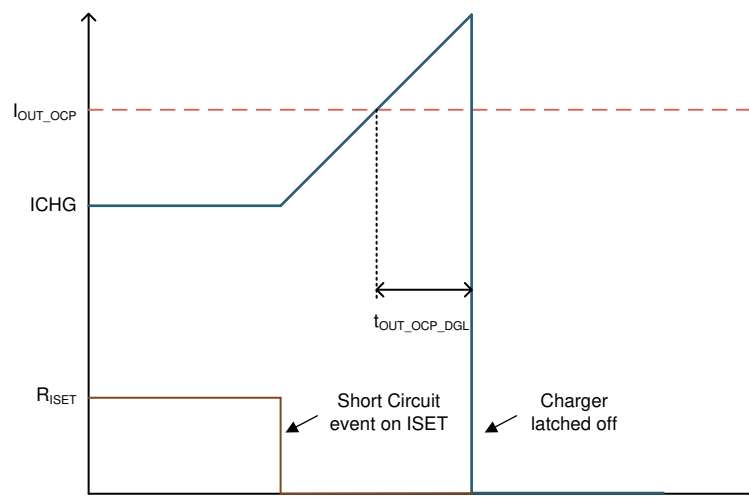

Figure 7-3. Overcurrent Protection

7.3.4.4 Thermal Regulation and Thermal Shutdown (TREG and TSHUT)

The device monitors its internal junction temperature (T_J) to avoid overheating and to limit the IC surface temperature. When the internal junction temperature exceeds the thermal regulation limit, the device automatically reduces the charge current to maintain the junction temperature at the thermal regulation limit (TREG). During thermal regulation, the safety timer runs at half the clock rate and the actual charging current is reduced below the programmed value on the ISET pin.

Additionally, the device has thermal shutdown to turn off the linear regulator when the IC junction temperature exceeds the TSHUT threshold. The charger resumes operation when the IC die temperature decreases below the TSHUT falling threshold.

7.4 Device Functional Modes

7.4.1 Shutdown or Undervoltage Lockout (UVLO)

The device is in the shutdown state if the IN pin voltage is less than V_{IN_LOWV} . The internal circuitry is powered down, all the pins are high impedance, and the device draws from the input supply. Once the IN voltage rises above the V_{IN_LOWV} threshold, the IC enters Sleep mode or Active mode depending on the OUT pin voltage.

7.4.2 Sleep Mode

The device is in Sleep mode when $V_{IN_LOWV} < V_{IN} < V_{OUT} + V_{SLEEPZ}$. The device waits for the input voltage to rise above $V_{OUT} + V_{SLEEPZ}$ to start operation.

7.4.3 Active Mode

The device is powered up and charges the battery when the TS pin is above V_{TS_ENZ} and the IN voltage ramps above both V_{IN_LOWV} and $V_{OUT} + V_{SLEEPZ}$. The device draws I_{Q_IN} from the supply to bias the internal circuitry. For details on the device power-up sequence, refer to [Section 7.3.1](#).

7.4.3.1 Standby Mode

The device is in Standby mode if a valid input supply is present and charge is terminated or if a recoverable fault is detected. The internal circuitry is partially biased, and the device continues to monitor for either V_{OUT} to drop below V_{RECHG} or the recoverable fault to be removed.

7.4.4 Fault Mode

The fault conditions are categorized into recoverable and nonrecoverable as follows:

- Recoverable, from which the device should automatically recover once the fault condition is removed:
 - VIN OVP
 - BAT OVP
 - TS HOT
 - TS COLD
- Nonrecoverable, requiring pin or input supply toggle to resume operation:
 - BAT OCP
 - ISET pin short detected
 - Charge timer expires with V_{OUT} below V_{RECHG}

8 Application and Implementation

Note

Information in the following applications sections is not part of the TI component specification, and TI does not warrant its accuracy or completeness. TI's customers are responsible for determining suitability of components for their purposes, as well as validating and testing their design implementation to confirm system functionality.

8.1 Application Information

A typical application consists of the device configured as a standalone battery charger for a 1-cell to 6-cell NiMH battery. The charge voltage and number of cells is configured using a pull-down resistor on the VSET pin. The charge current is configured using a pull-down resistor on the ISET pin. A battery thermistor may be connected to the TS pin to allow the device to monitor battery temperature and control charging. Pulling the TS pin below V_{TS_ENZ} disables the charging function. The safety timer is programmable through a pull-down resistor on the TMR pin. Faults are indicated through the STAT pin.

8.2 Typical Applications

8.2.1 NiMH Charger Design Example

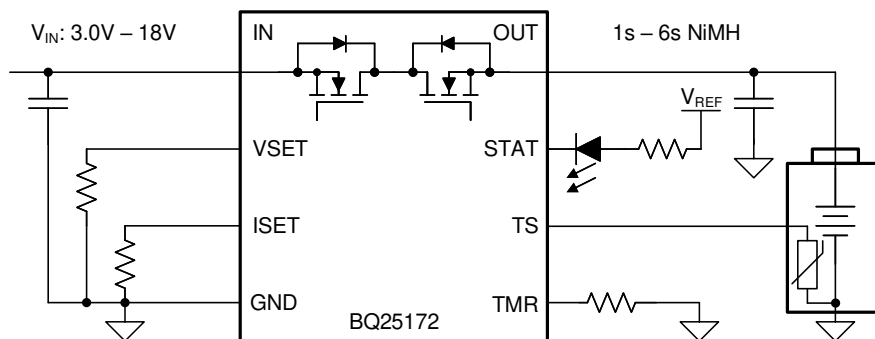

Figure 8-1. BQ25172 Simple Schematic

8.2.1.1 Design Requirements

The design requirements include the following:

- Input supply up to 18 V
- Battery: 4-cell NiMH, $R_{VSET} = 11 \text{ k}\Omega$
- Fast charge current: $I_{CHG} = 30 \text{ mA}$
- Recharge voltage for intermittent cycles: $V_{RECHG} = 1.33\text{V} \times 4 = 5.32 \text{ V}$
- Charge safety timer: $R_{TMR} = 8.2 \text{ k}\Omega$, $t_{SAFETY}: 16 \text{ hr}$
- TS – Battery temperature sense = 10-k Ω NTC (103AT-2)
- TS can be pulled low to disable charging

8.2.1.2 Detailed Design Procedure

The regulation voltage is set via the VSET pin to 2s NiMH, the input voltage is 5 V and the charge current is programmed via the ISET pin to 500 mA.

$$R_{ISET} = [K_{ISET} / I_{CHG}]$$

from electrical characteristics table. . . $K_{ISET} = 300 \text{ A}\Omega$

$$R_{ISET} = [300 \text{ A}\Omega / 0.5 \text{ A}] = 600 \Omega$$

Selecting the closest 1% resistor standard value, use a 604- Ω resistor between ISET and GND, for an expected I_{CHG} 497 mA.

8.2.1.3 Application Curves

$C_{IN} = 1 \mu\text{F}$, $C_{OUT} = 1 \mu\text{F}$, $V_{IN} = 5 \text{ V}$, $V_{OUT} = 3.8 \text{ V}$ (unless otherwise specified)

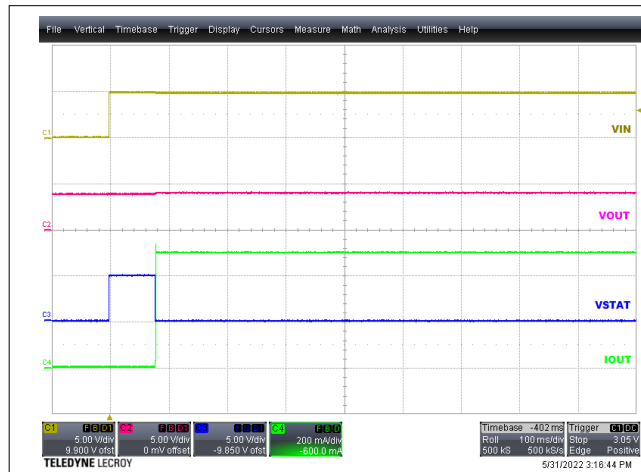

$R_{ISET} = 0.6 \text{ k}\Omega$

Figure 8-2. Power Up with Battery



$R_{ISET} = 0.6 \text{ k}\Omega$ OUT = open-circuit

Figure 8-3. Power Up without Battery



$V_{IN} = 5 \text{ V} \rightarrow 0 \text{ V}$

Figure 8-4. Power Down with Battery



TS pulled LOW

Figure 8-5. Charge Disable

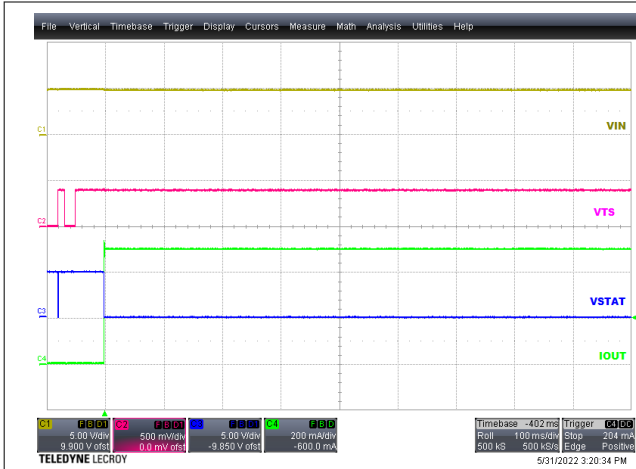

TS pin released

Figure 8-6. Charge Enable



VIN = 5 V → 10 V

Figure 8-7. Input OVP Response

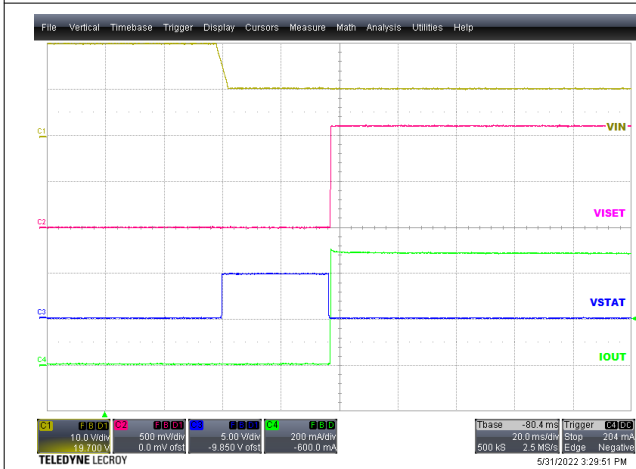

VIN = 20 V → 10 V

Figure 8-8. Input OVP Recovery

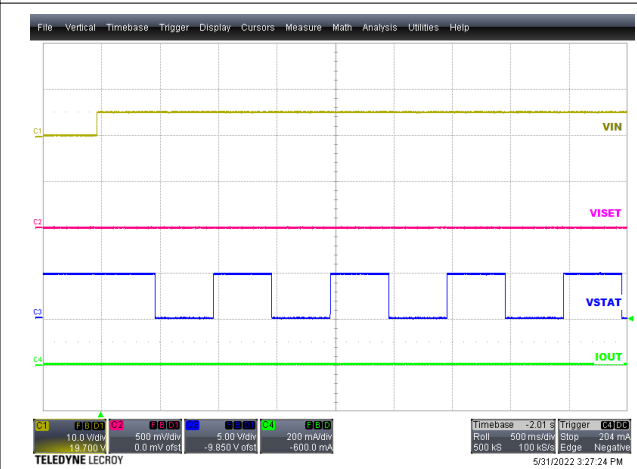

ISET = 0 Ω

Figure 8-9. ISET Short-Circuit Then Power Up

9 Power Supply Recommendations

The device is designed to operate from an input voltage supply range between 3 V and 18 V (tolerant up to 30 V) and current capability of at least the maximum designed charge current. If located more than a few inches from the IN and GND pins, a larger capacitor is recommended.

10 Layout

10.1 Layout Guidelines

To obtain optimal performance, the decoupling capacitor from the IN pin to the GND pin and the output filter capacitor from the OUT pin to the GND pin should be placed as close as possible to the device, with short trace runs to both IN, OUT, and GND.

- All low current GND connections should be kept separate from the high current charge or discharge paths from the battery. Use a single-point ground technique incorporating both the small signal ground path and the power ground path.
- The high current charge paths into the IN pin and from the OUT pin must be sized appropriately for the maximum charge current in order to avoid voltage drops in these traces.

10.2 Layout Example

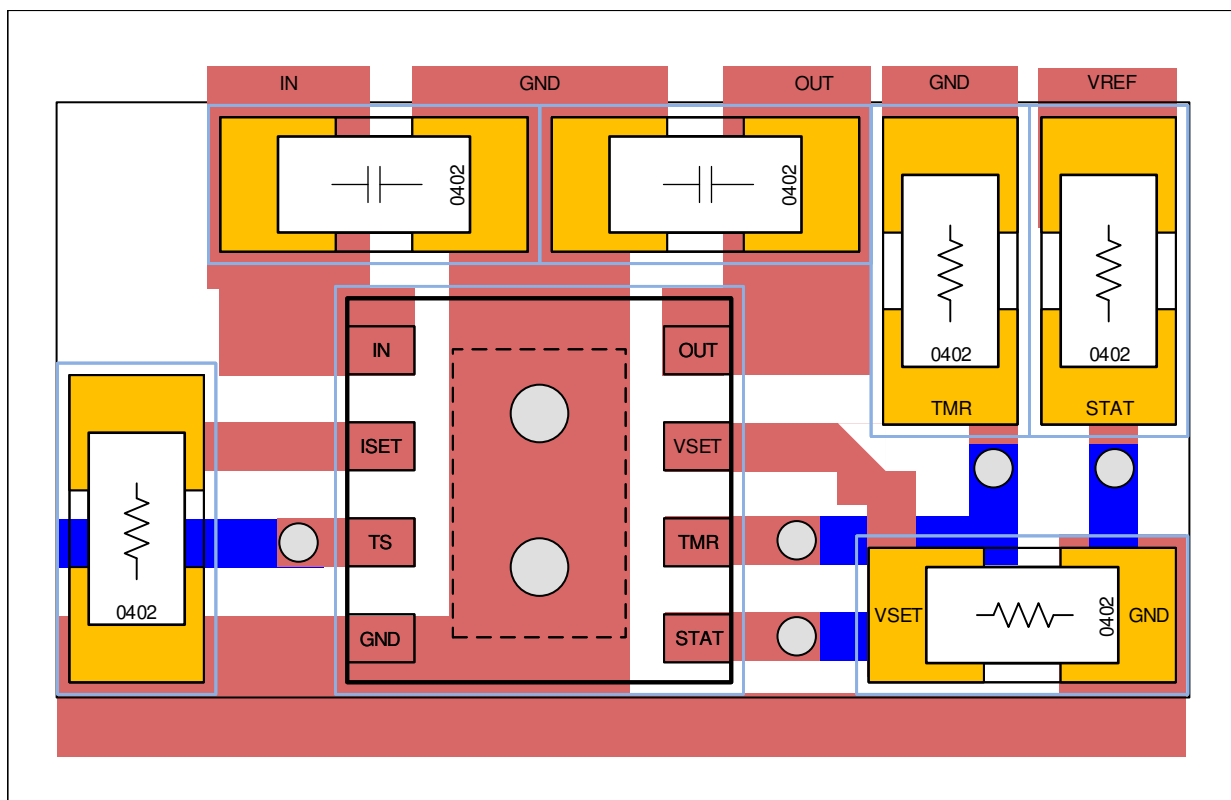

Figure 10-1. BQ25172 Layout Example

11 Device and Documentation Support

11.1 Device Support

11.1.1 Third-Party Products Disclaimer

TI'S PUBLICATION OF INFORMATION REGARDING THIRD-PARTY PRODUCTS OR SERVICES DOES NOT CONSTITUTE AN ENDORSEMENT REGARDING THE SUITABILITY OF SUCH PRODUCTS OR SERVICES OR A WARRANTY, REPRESENTATION OR ENDORSEMENT OF SUCH PRODUCTS OR SERVICES, EITHER ALONE OR IN COMBINATION WITH ANY TI PRODUCT OR SERVICE.

11.2 Receiving Notification of Documentation Updates

To receive notification of documentation updates, navigate to the device product folder on ti.com. Click on *Subscribe to updates* to register and receive a weekly digest of any product information that has changed. For change details, review the revision history included in any revised document.

11.3 Support Resources

[TI E2E™ support forums](#) are an engineer's go-to source for fast, verified answers and design help — straight from the experts. Search existing answers or ask your own question to get the quick design help you need.

Linked content is provided "AS IS" by the respective contributors. They do not constitute TI specifications and do not necessarily reflect TI's views; see TI's [Terms of Use](#).

11.4 Trademarks

TI E2E™ is a trademark of Texas Instruments.
All trademarks are the property of their respective owners.

11.5 Electrostatic Discharge Caution



This integrated circuit can be damaged by ESD. Texas Instruments recommends that all integrated circuits be handled with appropriate precautions. Failure to observe proper handling and installation procedures can cause damage.

ESD damage can range from subtle performance degradation to complete device failure. Precision integrated circuits may be more susceptible to damage because very small parametric changes could cause the device not to meet its published specifications.

11.6 Glossary

[TI Glossary](#) This glossary lists and explains terms, acronyms, and definitions.

12 Mechanical, Packaging, and Orderable Information

The following pages include mechanical, packaging, and orderable information. This information is the most current data available for the designated devices. This data is subject to change without notice and revision of this document. For browser-based versions of this data sheet, refer to the left-hand navigation.

PACKAGING INFORMATION

| Orderable part number | Status (1) | Material type (2) | Package Pins | Package qty Carrier | RoHS (3) | Lead finish/ Ball material (4) | MSL rating/ Peak reflow (5) | Op temp (°C) | Part marking (6) |
|-----------------------------|---------------|----------------------|----------------|-----------------------|-------------|--------------------------------------|-----------------------------------|--------------|---------------------|
| BQ25172DSGR | Active | Production | WSON (DSG) 8 | 3000 LARGE T&R | Yes | NIPDAU | Level-1-260C-UNLIM | -40 to 125 | B172 |

(1) **Status:** For more details on status, see our [product life cycle](#).

(2) **Material type:** When designated, preproduction parts are prototypes/experimental devices, and are not yet approved or released for full production. Testing and final process, including without limitation quality assurance, reliability performance testing, and/or process qualification, may not yet be complete, and this item is subject to further changes or possible discontinuation. If available for ordering, purchases will be subject to an additional waiver at checkout, and are intended for early internal evaluation purposes only. These items are sold without warranties of any kind.

(3) **RoHS values:** Yes, No, RoHS Exempt. See the [TI RoHS Statement](#) for additional information and value definition.

(4) **Lead finish/Ball material:** Parts may have multiple material finish options. Finish options are separated by a vertical ruled line. Lead finish/Ball material values may wrap to two lines if the finish value exceeds the maximum column width.

(5) **MSL rating/Peak reflow:** The moisture sensitivity level ratings and peak solder (reflow) temperatures. In the event that a part has multiple moisture sensitivity ratings, only the lowest level per JEDEC standards is shown. Refer to the shipping label for the actual reflow temperature that will be used to mount the part to the printed circuit board.

(6) **Part marking:** There may be an additional marking, which relates to the logo, the lot trace code information, or the environmental category of the part.

Multiple part markings will be inside parentheses. Only one part marking contained in parentheses and separated by a "-" will appear on a part. If a line is indented then it is a continuation of the previous line and the two combined represent the entire part marking for that device.

Important Information and Disclaimer:The information provided on this page represents TI's knowledge and belief as of the date that it is provided. TI bases its knowledge and belief on information provided by third parties, and makes no representation or warranty as to the accuracy of such information. Efforts are underway to better integrate information from third parties. TI has taken and continues to take reasonable steps to provide representative and accurate information but may not have conducted destructive testing or chemical analysis on incoming materials and chemicals. TI and TI suppliers consider certain information to be proprietary, and thus CAS numbers and other limited information may not be available for release.

In no event shall TI's liability arising out of such information exceed the total purchase price of the TI part(s) at issue in this document sold by TI to Customer on an annual basis.

TAPE AND REEL INFORMATION

QUADRANT ASSIGNMENTS FOR PIN 1 ORIENTATION IN TAPE

*All dimensions are nominal

| Device | Package Type | Package Drawing | Pins | SPQ | Reel Diameter (mm) | Reel Width W1 (mm) | A0 (mm) | B0 (mm) | K0 (mm) | P1 (mm) | W (mm) | Pin1 Quadrant |
|-------------|--------------|-----------------|------|------|--------------------|--------------------|---------|---------|---------|---------|--------|---------------|
| BQ25172DSGR | WSO | DSG | 8 | 3000 | 180.0 | 8.4 | 2.3 | 2.3 | 1.15 | 4.0 | 8.0 | Q2 |

TAPE AND REEL BOX DIMENSIONS

*All dimensions are nominal

| Device | Package Type | Package Drawing | Pins | SPQ | Length (mm) | Width (mm) | Height (mm) |
|-------------|--------------|-----------------|------|------|-------------|------------|-------------|
| BQ25172DSGR | WSON | DSG | 8 | 3000 | 210.0 | 185.0 | 35.0 |

GENERIC PACKAGE VIEW

DSG 8

WSON - 0.8 mm max height

2 x 2, 0.5 mm pitch

PLASTIC SMALL OUTLINE - NO LEAD

This image is a representation of the package family, actual package may vary.
Refer to the product data sheet for package details.



4224783/A

DSG0008A

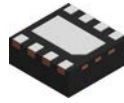

PACKAGE OUTLINE

WSON - 0.8 mm max height

PLASTIC SMALL OUTLINE - NO LEAD

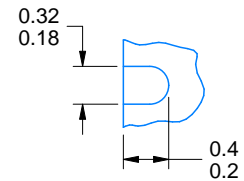
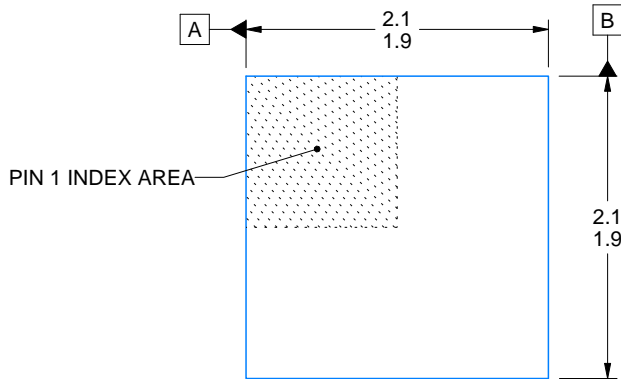

ALTERNATIVE TERMINAL SHAPE TYPICAL

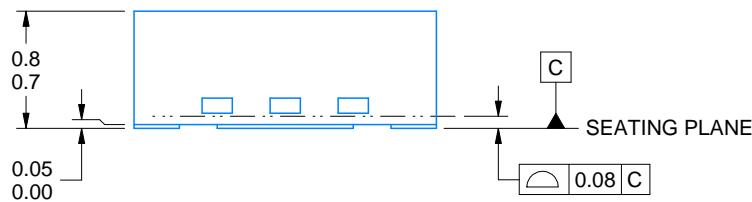

| SIDE WALL METAL THICKNESS DIM A | |
|---------------------------------|----------|
| OPTION 1 | OPTION 2 |
| 0.1 | 0.2 |

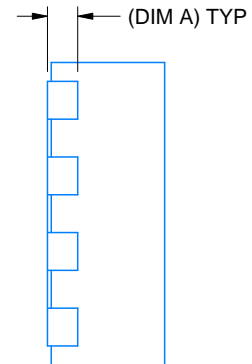
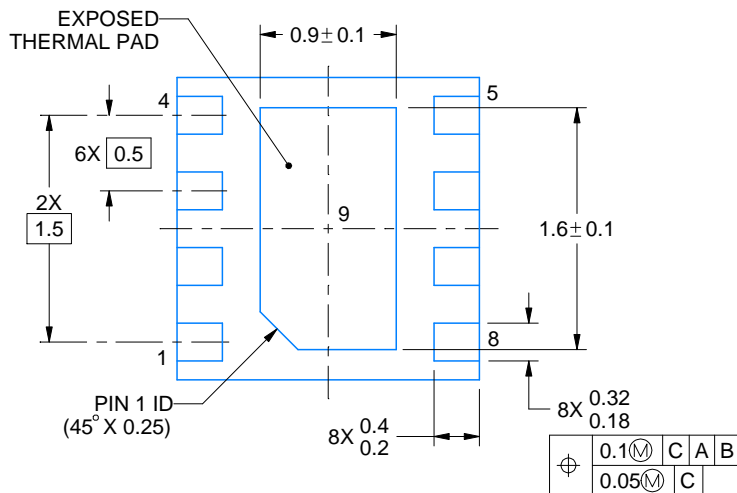

4218900/E 08/2022

NOTES:

1. All linear dimensions are in millimeters. Any dimensions in parenthesis are for reference only. Dimensioning and tolerancing per ASME Y14.5M.
2. This drawing is subject to change without notice.
3. The package thermal pad must be soldered to the printed circuit board for thermal and mechanical performance.

EXAMPLE STENCIL DESIGN

DSG0008A

WSON - 0.8 mm max height

PLASTIC SMALL OUTLINE - NO LEAD

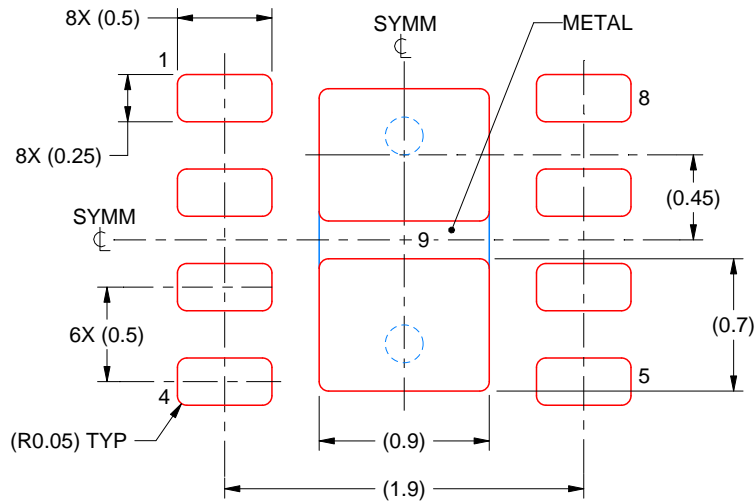

SOLDER PASTE EXAMPLE
BASED ON 0.125 mm THICK STENCIL

EXPOSED PAD 9:
87% PRINTED SOLDER COVERAGE BY AREA UNDER PACKAGE
SCALE:25X

4218900/E 08/2022

NOTES: (continued)

6. Laser cutting apertures with trapezoidal walls and rounded corners may offer better paste release. IPC-7525 may have alternate design recommendations.

IMPORTANT NOTICE AND DISCLAIMER

TI PROVIDES TECHNICAL AND RELIABILITY DATA (INCLUDING DATA SHEETS), DESIGN RESOURCES (INCLUDING REFERENCE DESIGNS), APPLICATION OR OTHER DESIGN ADVICE, WEB TOOLS, SAFETY INFORMATION, AND OTHER RESOURCES "AS IS" AND WITH ALL FAULTS, AND DISCLAIMS ALL WARRANTIES, EXPRESS AND IMPLIED, INCLUDING WITHOUT LIMITATION ANY IMPLIED WARRANTIES OF MERCHANTABILITY, FITNESS FOR A PARTICULAR PURPOSE OR NON-INFRINGEMENT OF THIRD PARTY INTELLECTUAL PROPERTY RIGHTS.

These resources are intended for skilled developers designing with TI products. You are solely responsible for (1) selecting the appropriate TI products for your application, (2) designing, validating and testing your application, and (3) ensuring your application meets applicable standards, and any other safety, security, regulatory or other requirements.

These resources are subject to change without notice. TI grants you permission to use these resources only for development of an application that uses the TI products described in the resource. Other reproduction and display of these resources is prohibited. No license is granted to any other TI intellectual property right or to any third party intellectual property right. TI disclaims responsibility for, and you will fully indemnify TI and its representatives against, any claims, damages, costs, losses, and liabilities arising out of your use of these resources.

TI's products are provided subject to [TI's Terms of Sale](#) or other applicable terms available either on [ti.com](https://www.ti.com) or provided in conjunction with such TI products. TI's provision of these resources does not expand or otherwise alter TI's applicable warranties or warranty disclaimers for TI products.

TI objects to and rejects any additional or different terms you may have proposed.

Mailing Address: Texas Instruments, Post Office Box 655303, Dallas, Texas 75265

Copyright © 2025, Texas Instruments Incorporated

Looking for pricing, stock, or lifecycle information?

Click below to explore more details on WIN SOURCE:

 [View BQ25172DSGR](#) on WIN SOURCE

 [Texas Instruments](#) Information

Optimize Your Supply Chain with WIN SOURCE Solutions

-  Global Sourcing Solution
-  Obsolete Management
-  Cost Control Management
-  Shortage Management
-  Alternative Solution
-  Excess Inventory Management