

Power Inductor ADCC Series

**Automotive
AEC-Q200**

RoHS Compliant
Halogen Free
REACH Compliant



- Power Circuit
- Shield
- Wire Wound
- Metal
- Ultra High Current

Part Numbering

A	DCC	00	201612	1R0	M	C1
Grade	Series Name	Control Code	Dimensions Code (mm)	Inductance (uH)	Tolerance	Internal Code
			201612 2.0x1.6x1.2	R15 0.15	M ±20%	
			252012 2.5x2.0x1.2	R24 0.24		
				R33 0.33		
				R47 0.47		
				1R0 1.00		
				1R5 1.50		

Please be sure to request approval specifications that provide further details of the products. Kindly note that the content of these specifications are subject to change or may be discontinued without prior notice. This product may not be designed/used in medical or high risk applications without Chilisin approval. Please contact our sales department before ordering.

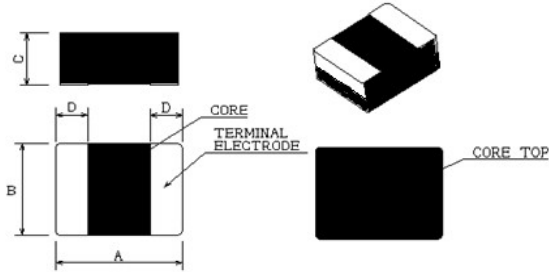
ADCC00201612 Type
■ Dimensions

unit:mm

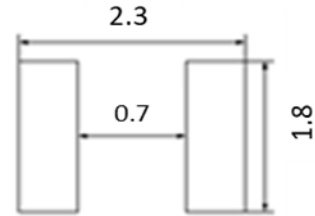
■ Recommended Land Pattern

unit:mm

■ Electrical Characteristics

Part No.	Inductance (uH)	Test Freq.	RDC(mΩ) Max(Typ)	Isat(A) Max(Typ)	Irms(A) Max(Typ)	Tolerance (±%)
ADCC00201612R15MC1	0.15	2MHz	16(10)	7.7(8.6)	5.5(6.9)	20
ADCC00201612R24MC1	0.24	2MHz	21(16)	5.9(6.5)	5.0(6.2)	20
ADCC00201612R33MC1	0.33	2MHz	27(22)	5.2(5.8)	4.3(4.8)	20
ADCC00201612R47MC1	0.47	2MHz	30(24)	4.5(5.0)	3.9(4.5)	20
ADCC002016121R0MC1	1.00	2MHz	50(43)	3.3(3.7)	3.1(3.4)	20
ADCC002016121R5MC1	1.50	2MHz	95(90)	2.5(2.8)	2.3(2.6)	20

Note: When ordering, please specify tolerance code. Tolerance: M=±20%

- Operating temperature range: -40°C~125°C (Including self-temperature rise)
- Isat for Inductance drop 30% from its initial inductance value without applying current
- Irms for a 40°C temperature rise from 25°C ambient with applying current
- Rated current: Isat or Irms, whichever is smaller
- Absolute maximum voltage: 20VDC
- Measure Equipment:
 - L: WK 6500B/HP4285A (or equivalent), 2MHz
 - RDC: Chen Hwa 502BC/HP4338B (or equivalent)
 - Isat: Agilent E4980A+HP42841A (or equivalent)
 - Irms: Agilent 6641 system DC power supply (or equivalent)

ADCC00201612 Type

■ Characteristics Graph

Inductance vs.DC Current

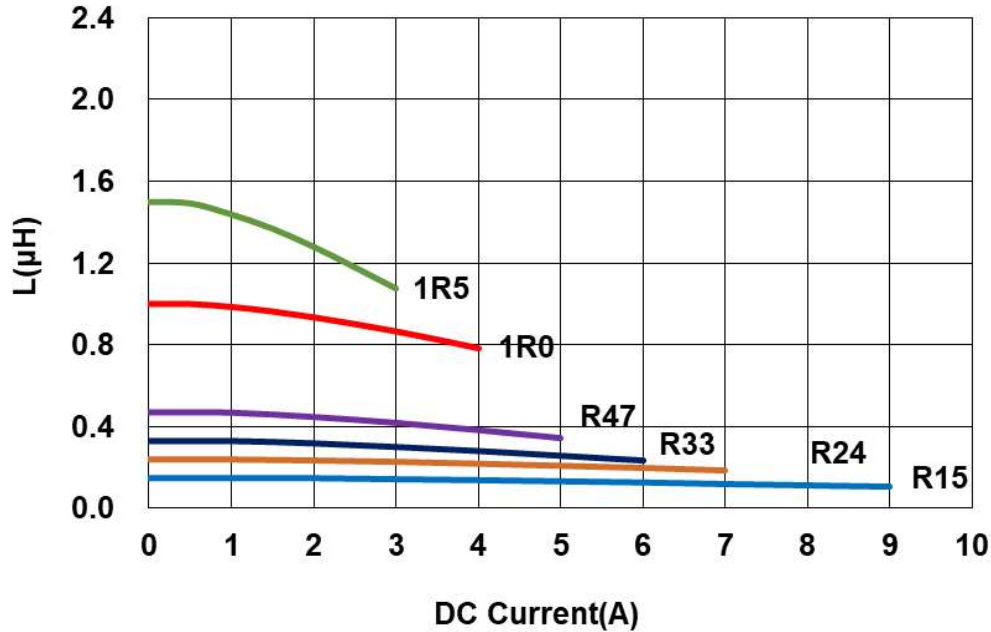

Temperature Change vs. DC Current

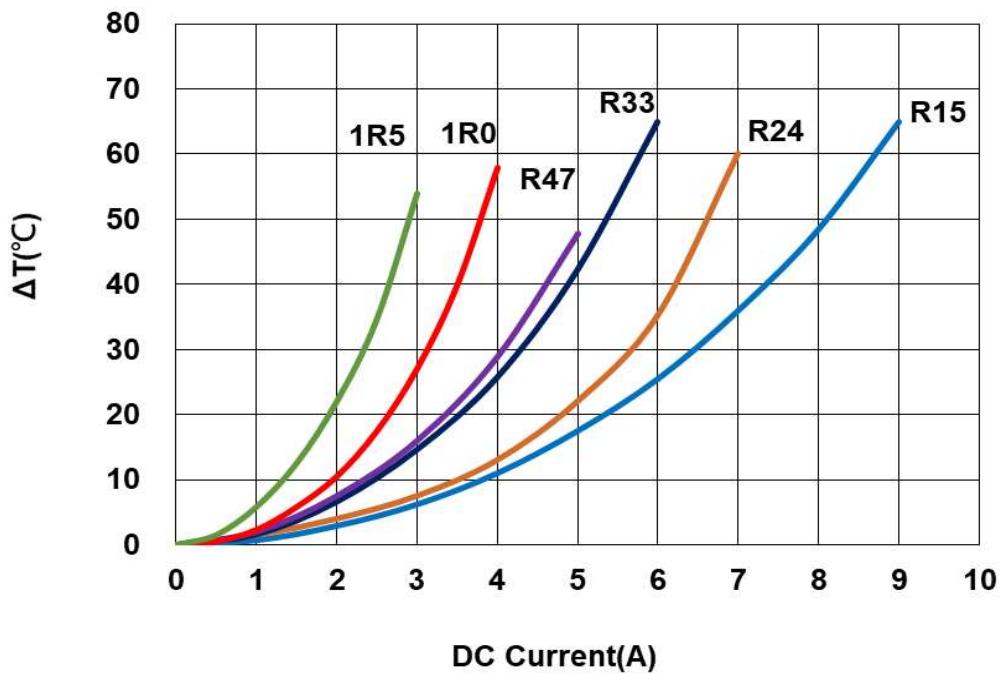

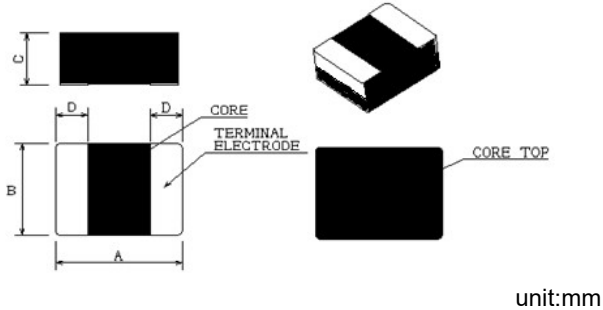
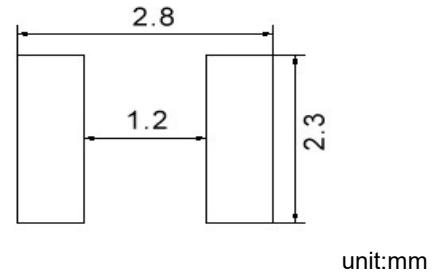
ADCC00252012 Type
Dimensions

Recommended Land Pattern

Electrical Characteristics

Part No.	Inductance (uH)	Test Freq.	RDC(mΩ) Max(Typ)	Isat(A) Max(Typ)	Irms(A) Max(Typ)	Tolerance (±%)
ADCC00252012R24MC1	0.24	2MHz	13(8)	8.0(9.0)	6.7(8.5)	20
ADCC00252012R33MC1	0.33	2MHz	22(16)	6.2(7.0)	4.7(5.4)	20
ADCC00252012R47MC1	0.47	2MHz	27(21)	5.2(6.1)	4.0(4.7)	20
ADCC002520121R0MC1	1.00	2MHz	42(35)	3.7(4.3)	3.3(3.8)	20
ADCC002520121R5MC1	1.50	2MHz	60(55)	3.4(3.8)	2.6(2.9)	20
ADCC002520122R2MC1	2.20	2MHz	92(85)	2.8(3.1)	2.1(2.3)	20

Note: When ordering, please specify tolerance code. Tolerance: M=±20%

- Operating temperature range: -40°C~125°C (Including self-temperature rise)
- Isat for Inductance drop 30% from its initial inductance value without applying current
- Irms for a 40°C temperature rise from 25°C ambient with applying current
- Rated current: Isat or Irms, whichever is smaller
- Absolute maximum voltage: 20VDC
- Measure Equipment:
 - L: WK 6500B/HP4285A (or equivalent), 2MHz
 - RDC: Chen Hwa 502BC/HP4338B (or equivalent)
 - Isat: Agilent E4980A+HP42841A (or equivalent)
 - Irms: Agilent 6641 system DC power supply (or equivalent)

ADCC00252012 Type

■ Characteristics Graph

Inductance vs.DC Current

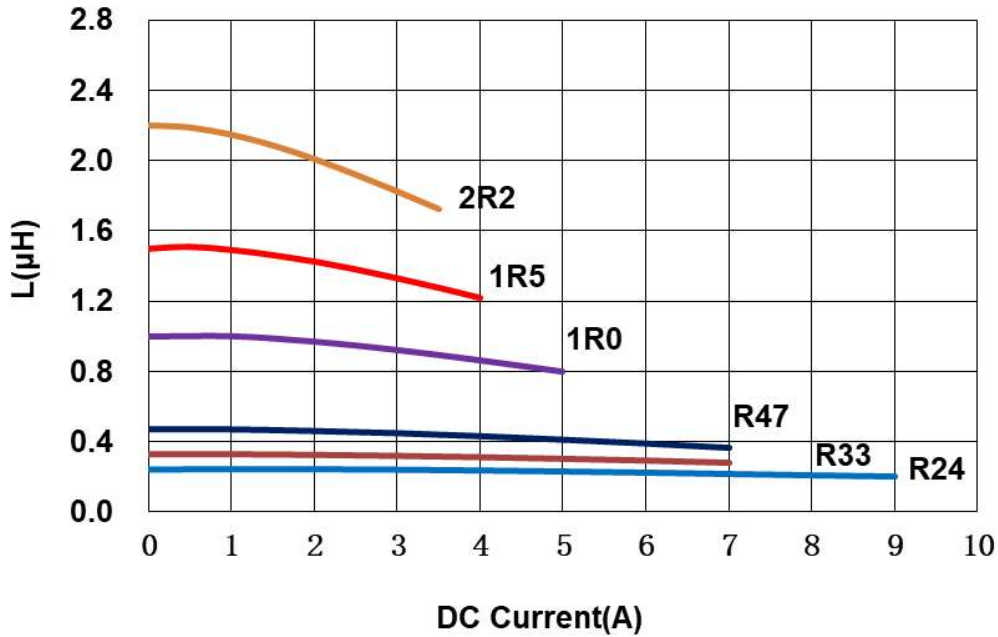

Temperature Change vs. DC Current

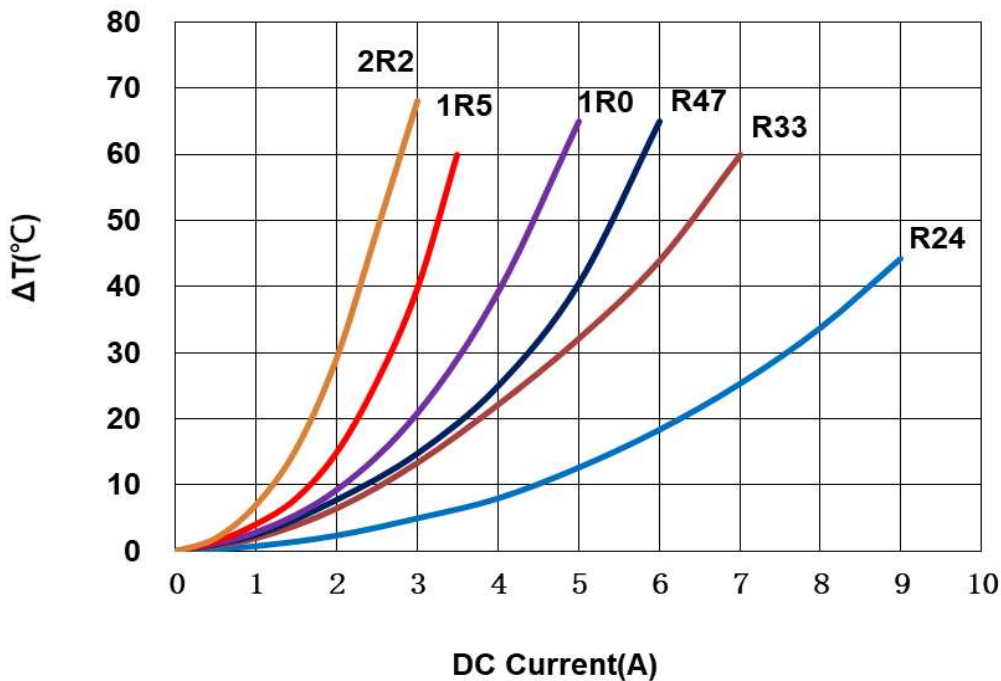

■ Packaging

Tape Dimensions

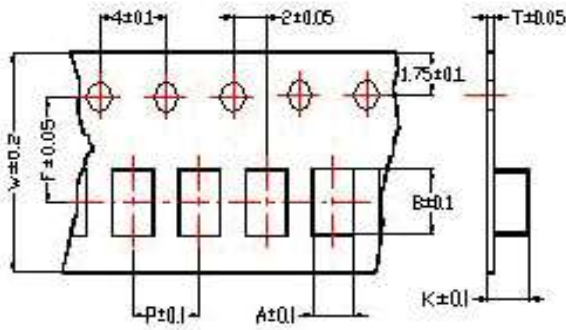

Tape Material

Carrier Tape: Polycarbonate
Cover Tape: Polystyrene

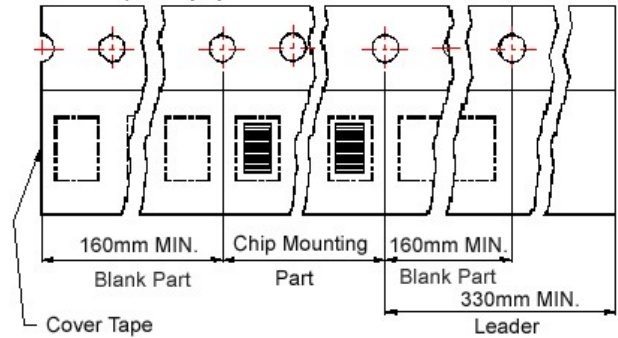

Reel Dimensions

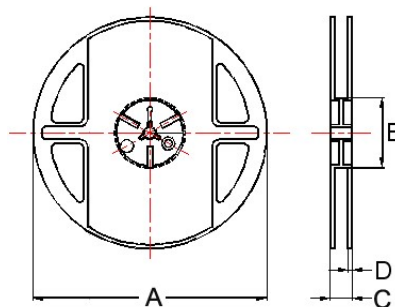

Dimensions in mm

TYPE	Tape Dimensions							Reel Dimensions				Quantity PCS / Reel
	A	B	T	W	P	F	K	A	B	C	D	
ADCC00201612	1.90	2.20	0.22	8	4	3.5	1.15	178	60	12	2	3000
ADCC00252012	2.30	2.80	0.22	8	4	3.5	1.35	178	60	12	2	3000

Looking for pricing, stock, or lifecycle information?

Click below to explore more details on WIN SOURCE:

-  [View ADCC002016121R0MC1 on WIN SOURCE](#)
-  [Pulse Information](#)

Optimize Your Supply Chain with WIN SOURCE Solutions

-  Global Sourcing Solution
-  Obsolete Management
-  Cost Control Management
-  Shortage Management
-  Alternative Solution
-  Excess Inventory Management