

4RCD0232KC1

DDR4RCD02 Register Command Address Buffer and Parity

The 4RCD0232KC1 is a 32-bit 1:2 register command, address buffer with parity, designed for 1.2V VDD operation. The device is intended for RDIMM/LRDIMM applications.

[Planned] decode logic to support DIMMs that populate eight ranks of memory or higher. [Planned] additional SI features to support DIMMs greater than 30mm height.

All inputs are pseudo-differential with an external or internal voltage reference. All outputs are full swing CMOS drivers optimized to drive single terminated 25Ω to 50Ω traces in DDR4 RDIMM and LRDIMM applications. The clock outputs Yn_t and Yn_c and the control net outputs QxCKEn, QxCsN and QxODTn can be driven with a different strengths to compensate for different DIMM net topologies. By disabling unused outputs the power consumption is reduced.

The 4RCD0232KC1 operates from a differential clock, CK_t and CK_c. Inputs are registered at the crossing of CK_t going HIGH, and CK_c going LOW. The input signals could be either re-driven to the outputs or they could be used to access device internal control registers when certain input conditions are met. The control word mechanism is described in more detail in the “Control Word Decoding” section of the datasheet.

Applications

- DDR4 RDIMM
- DDR4 LRDIMM

Features

- Pinout optimized DDR4 RDIMM PCB layout
- DDR4-1600/1866/2133/2400/2666/2933/3200
- Supports CKE Power Down operation modes
- Support Quad Chip Select Operation
 - Direct Dual CS Mode
 - Direct QuadCS Mode
 - Encoded QuadCS Mode
- Provides access to internal control words for configuring the device features and adapting in different RDIMM and system applications
- Compliant to JEDEC DDR4RCD02 Specification, Revision 1.0
- Packaging: 253-ball dual-pitch (0.50mm/0.65mm), 15 × 20 grid, rectangular BGA
 - Available in commercial temp. range (0°C to 70°C) and industrial temp. range (-40°C to 85°C)

Block Diagram

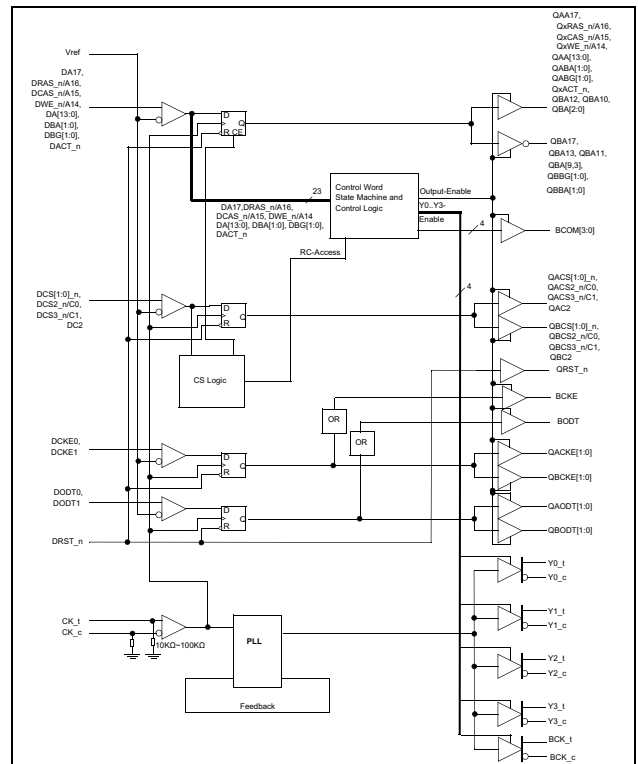

IMPORTANT NOTICE AND DISCLAIMER

RENESAS ELECTRONICS CORPORATION AND ITS SUBSIDIARIES (“RENESAS”) PROVIDES TECHNICAL SPECIFICATIONS AND RELIABILITY DATA (INCLUDING DATASHEETS), DESIGN RESOURCES (INCLUDING REFERENCE DESIGNS), APPLICATION OR OTHER DESIGN ADVICE, WEB TOOLS, SAFETY INFORMATION, AND OTHER RESOURCES “AS IS” AND WITH ALL FAULTS, AND DISCLAIMS ALL WARRANTIES, EXPRESS OR IMPLIED, INCLUDING, WITHOUT LIMITATION, ANY IMPLIED WARRANTIES OF MERCHANTABILITY, FITNESS FOR A PARTICULAR PURPOSE, OR NON-INFRINGEMENT OF THIRD-PARTY INTELLECTUAL PROPERTY RIGHTS.

These resources are intended for developers who are designing with Renesas products. You are solely responsible for (1) selecting the appropriate products for your application, (2) designing, validating, and testing your application, and (3) ensuring your application meets applicable standards, and any other safety, security, or other requirements. These resources are subject to change without notice. Renesas grants you permission to use these resources only to develop an application that uses Renesas products. Other reproduction or use of these resources is strictly prohibited. No license is granted to any other Renesas intellectual property or to any third-party intellectual property. Renesas disclaims responsibility for, and you will fully indemnify Renesas and its representatives against, any claims, damages, costs, losses, or liabilities arising from your use of these resources. Renesas' products are provided only subject to Renesas' Terms and Conditions of Sale or other applicable terms agreed to in writing. No use of any Renesas resources expands or otherwise alters any applicable warranties or warranty disclaimers for these products.

(Disclaimer Rev.1.01)

Corporate Headquarters

TOYOSU FORESIA, 3-2-24 Toyosu,
Koto-ku, Tokyo 135-0061, Japan
www.renesas.com

Trademarks

Renesas and the Renesas logo are trademarks of Renesas Electronics Corporation. All trademarks and registered trademarks are the property of their respective owners.

Contact Information

For further information on a product, technology, the most up-to-date version of a document, or your nearest sales office, please visit www.renesas.com/contact-us/.

Looking for pricing, stock, or lifecycle information?

Click below to explore more details on WIN SOURCE:

 [View N82C08-8 on WIN SOURCE](#)

 [Altera Information](#)

Optimize Your Supply Chain with WIN SOURCE Solutions

-  Global Sourcing Solution
-  Obsolete Management
-  Cost Control Management
-  Shortage Management
-  Alternative Solution
-  Excess Inventory Management