



# THE DATASHEET OF F5NK100Z





# STP5NK100Z, STF5NK100Z STW5NK100Z

N-channel 1000 V, 2.7  $\Omega$ , 3.5 A, TO-220, TO-220FP, TO-247  
SuperMESH3™ Power MOSFET

## Features

Type	V <sub>DSS</sub> (@T <sub>JMAX</sub> )	R <sub>DS(on)</sub> max	I <sub>D</sub>
STF5NK100Z	1000 V	< 3.7 $\Omega$	3.5 A
STP5NK100Z	1000 V	< 3.7 $\Omega$	3.5 A
STW5NK100Z	1000 V	< 3.7 $\Omega$	3.5 A

- Extremely high dv/dt capability
- 100% avalanche tested
- Gate charge minimized
- Very low intrinsic capacitances
- Very good manufacturing repeatability

## Applications

- Switching application

## Description

The new SuperMESH™ series of Power MOSFETS is the result of further design improvements on ST's well-established strip-based PowerMESH™ layout. In addition to significantly lower on-resistance, the device offers superior dv/dt capability to ensure optimal performance even in the most demanding applications. The SuperMESH™ devices further complement an already broad range of innovative high voltage MOSFETs, which includes the revolutionary MDmesh™ products.

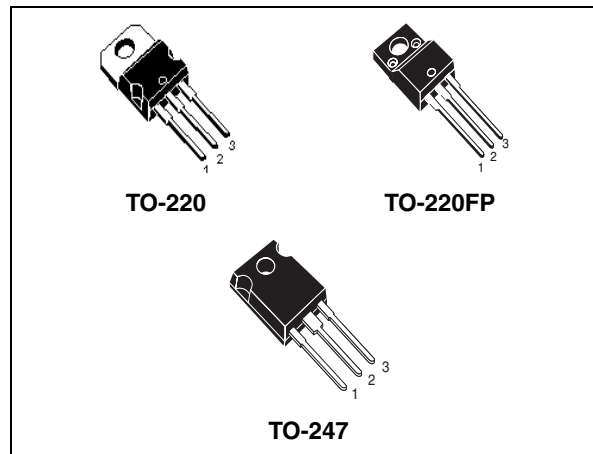

Figure 1. Internal schematic diagram

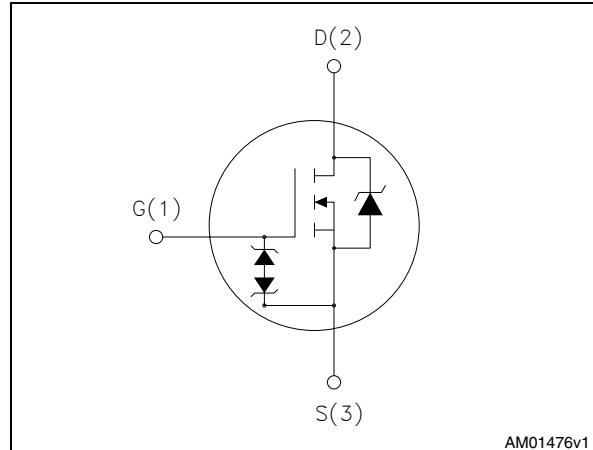

Table 1. Device summary

Order code	Marking	Package	Packaging
STF5NK100Z	F5NK100Z	TO-220FP	Tube
STP5NK100Z	P5NK100Z	TO-220	Tube
STW5NK100Z	W5NK100Z	TO-247	Tube

# Contents

<b>1</b>	<b>Electrical ratings</b> .....	<b>3</b>
<b>2</b>	<b>Electrical characteristics</b> .....	<b>4</b>
2.1	Electrical characteristics (curves) .....	6
<b>3</b>	<b>Test circuit</b> .....	<b>9</b>
<b>4</b>	<b>Package mechanical data</b> .....	<b>10</b>
<b>5</b>	<b>Revision history</b> .....	<b>14</b>

# 1 Electrical ratings

**Table 2. Absolute maximum ratings**

Symbol	Parameter	Value		Unit
		TO-220, TO-247	TO-220FP	
$V_{DS}$	Drain-source voltage ( $V_{GS} = 0$ )	1000		V
$V_{GS}$	Gate-source voltage	$\pm 30$		V
$I_D$	Drain current (continuous) at $T_C = 25^\circ\text{C}$	3.5	3.5 <sup>(1)</sup>	A
$I_D$	Drain current (continuous) at $T_C=100^\circ\text{C}$	2.2	2.2 <sup>(1)</sup>	A
$I_{DM}^{(2)}$	Drain current (pulsed)	14	14 <sup>(1)</sup>	A
$P_{TOT}$	Total dissipation at $T_C = 25^\circ\text{C}$	125	30	W
	Derating factor	1	0.24	W/°C
$V_{ESD(G-S)}$	Gate source ESD (HBM-C=100pF, R=1.5 k $\Omega$ )	4000		V
$dv/dt^{(3)}$	Peak diode recovery voltage slope	4.5		V/ns
$V_{ISO}$	Insulation withstand voltage (RMS) from all three leads to external heat sink ( $t=1$ s; $T_C= 25^\circ\text{C}$ )		2500	V
$T_J$ $T_{stg}$	Operating junction temperature Storage temperature	-55 to 150		°C

- Limited only by maximum temperature allowed
- Pulse width limited by safe operating area
- $I_{SD} \leq 3.5$  A,  $di/dt \leq 200$  A/ $\mu\text{s}$ ,  $V_{DD} \leq V_{(BR)DSS}$ ,  $T_J \leq T_{JMAX}$ .

**Table 3. Thermal data**

Symbol	Parameter	Value		Unit
		TO-220, TO-247	TO-220FP	
$R_{thj-case}$	Thermal resistance junction-case max	1	4.2	°C/W
$R_{thj-a}$	Thermal resistance junction-ambient max	62.5		°C/W
$T_l$	Maximum lead temperature for soldering purpose	300		°C

**Table 4. Avalanche characteristics**

Symbol	Parameter	Value	Unit
$I_{AR}$	Avalanche current, repetitive or not-repetitive (pulse width limited by $T_{JMAX}$ )	3.5	A
$E_{AS}$	Single pulse avalanche energy (starting $T_J=25^\circ\text{C}$ , $I_d=I_{AR}$ , $V_{dd}=50$ V)	250	mJ

## 2 Electrical characteristics

( $T_{CASE}=25^{\circ}C$  unless otherwise specified)

**Table 5. On/off states**

Symbol	Parameter	Test conditions	Min.	Typ.	Max.	Unit
$V_{(BR)DSS}$	Drain-source breakdown voltage	$I_D = 1 \text{ mA}, V_{GS} = 0$	1000			V
$I_{DSS}$	Zero gate voltage drain current ( $V_{GS} = 0$ )	$V_{DS} = \text{Max rating},$ $V_{DS} = \text{Max rating},$ $T_c = 125^{\circ}C$			1 50	$\mu A$ $\mu A$
$I_{GSS}$	Gate body leakage current ( $V_{GS} = 0$ )	$V_{GS} = \pm 20 \text{ V}$			$\pm 10$	$\mu A$
$V_{GS(th)}$	Gate threshold voltage	$V_{DS} = V_{GS}, I_D = 100 \mu A$	3	3.75	4.5	V
$R_{DS(on)}$	Static drain-source on resistance	$V_{GS} = 10 \text{ V}, I_D = 1.75 \text{ A}$		2.7	3.7	$\Omega$

**Table 6. Dynamic**

Symbol	Parameter	Test conditions	Min.	Typ.	Max.	Unit
$g_{fs}^{(1)}$	Forward transconductance	$V_{DS} = 15 \text{ V}, I_D = 1.75 \text{ A}$	-	4		S
$C_{iss}$	Input capacitance	$V_{DS} = 25 \text{ V}, f = 1 \text{ MHz},$ $V_{GS} = 0$	-	1154		pF
$C_{oss}$	Output capacitance			106		pF
$C_{rss}$	Reverse transfer capacitance			21.3		pF
$C_{osseq}^{(2)}$	Equivalent output capacitance	$V_{GS} = 0, V_{DS} = 0 \text{ V to } 800 \text{ V}$	-	46.8		pF
$t_{d(on)}$	Turn-on delay time	$V_{DD} = 500 \text{ V}, I_D = 1.75 \text{ A},$ $R_G = 4.7 \Omega, V_{GS} = 10 \text{ V}$ (see <a href="#">Figure 21</a> )	-	22.5		ns
$t_r$	Rise time			7.7		ns
$t_{d(off)}$	Off-voltage rise time			51.5		ns
$t_f$	Fall time			19		ns
$Q_g$	Total gate charge	$V_{DD} = 800 \text{ V}, I_D = 3.5 \text{ A}$ $V_{GS} = 10 \text{ V}$ (see <a href="#">Figure 22</a> )	-	42	59	nC
$Q_{gs}$	Gate-source charge			7.3		nC
$Q_{gd}$	Gate-drain charge			21.7		nC

1. Pulsed: pulse duration=300  $\mu s$ , duty cycle 1.5%

2.  $C_{oss eq.}$  is defined as a constant equivalent capacitance giving the same charging time as  $C_{oss}$  when  $V_{DS}$  increases from 0 to 80%  $V_{DSS}$

**Table 7. Source drain diode**

Symbol	Parameter	Test conditions	Min.	Typ.	Max.	Unit
$I_{SD}$	Source-drain current		-		3.5	A
$I_{SDM}^{(1)}$	Source-drain current (pulsed)		-		14	A
$V_{SD}^{(2)}$	Forward on voltage	$I_{SD}=3.5\text{ A}$ , $V_{GS}=0$	-		1.6	V
$t_{rr}$ $Q_{rr}$ $I_{RRM}$	Reverse recovery time Reverse recovery charge Reverse recovery current	$I_{SD}=3.5\text{ A}$ , $di/dt = 100\text{ A}/\mu\text{s}$ , $V_{DD}=30\text{ V}$ (see <a href="#">Figure 23</a> )	-	605 3.09 10.5		ns $\mu\text{C}$ A
$t_{rr}$ $Q_{rr}$ $I_{RRM}$	Reverse recovery time Reverse recovery charge Reverse recovery current	$I_{SD}=3.5\text{ A}$ , $di/dt = 100\text{ A}/\mu\text{s}$ , $V_{DD}=35\text{ V}$ , $T_j=150\text{ }^\circ\text{C}$ (see <a href="#">Figure 23</a> )	-	742 4.2 11.2		ns $\mu\text{C}$ A

1. Pulse width limited by safe operating area
2. Pulsed: pulse duration=300  $\mu\text{s}$ , duty cycle 1.5%

**Table 8. Gate-source Zener diode**

Symbol	Parameter	Test conditions	Min.	Typ.	Max.	Unit
$BV_{GSO}$	Gate-source breakdown voltage	$I_{gs}=\pm 1\text{ mA}$ (open drain)	30			V

The built-in back-to-back Zener diodes have specifically been designed to enhance not only the device's ESD capability, but also to make them safely absorb possible voltage transients that may occasionally be applied from gate to source. In this respect the Zener voltage is appropriate to achieve an efficient and cost-effective intervention to protect the device's integrity. These integrated Zener diodes thus avoid the usage of external components.

## 2.1 Electrical characteristics (curves)

Figure 2. Safe operating area for TO-220FP

Figure 3. Thermal impedance for TO-220FP

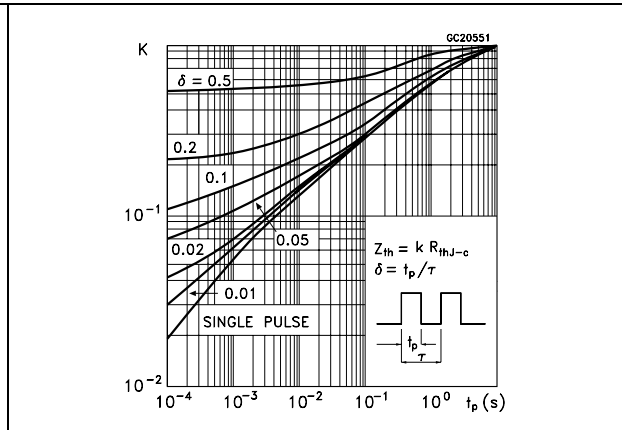
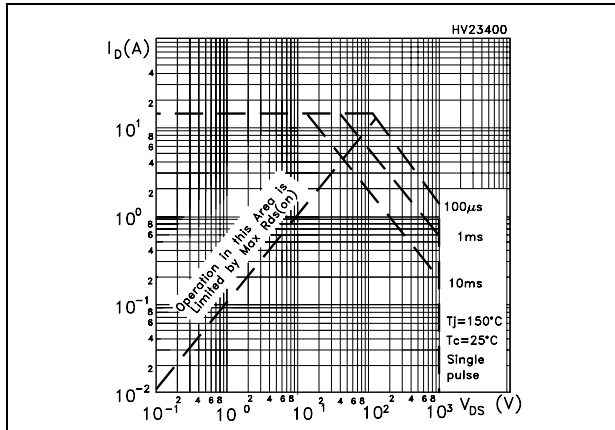

Figure 4. Safe operating area for TO-220

Figure 5. Thermal impedance for TO-220

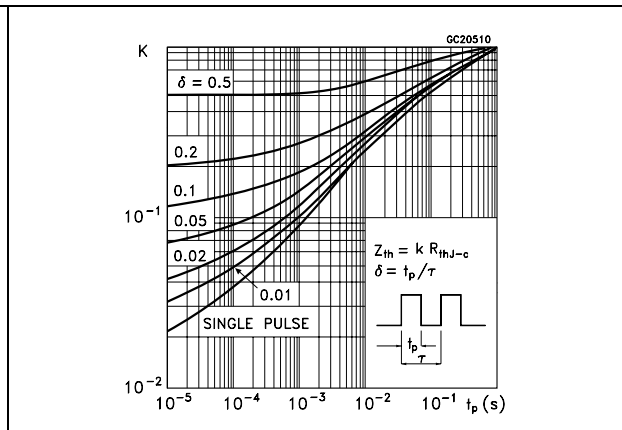
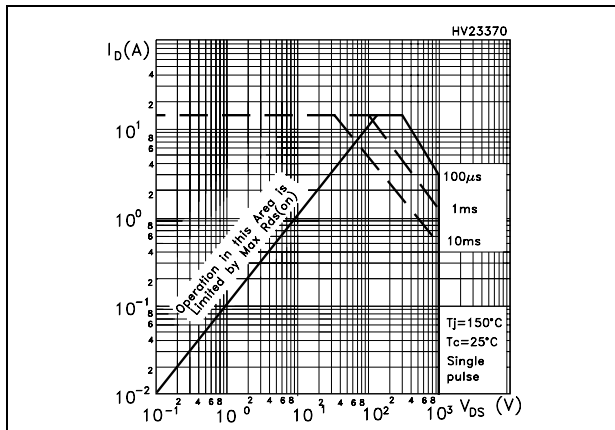

Figure 6. Safe operating area for TO-247

Figure 7. Thermal impedance for TO-247

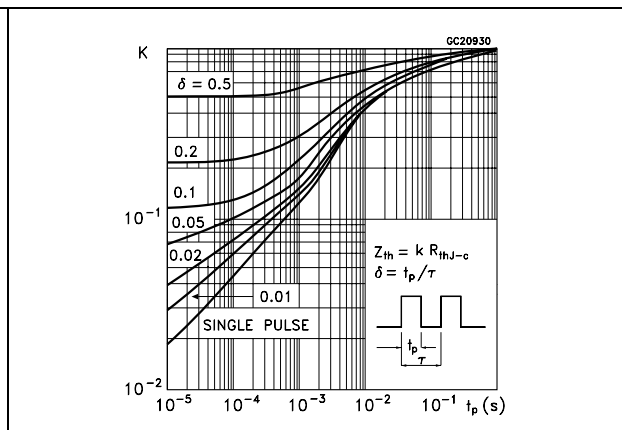
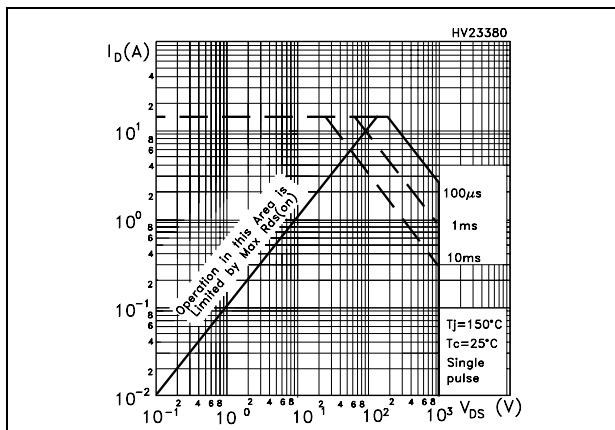

Figure 8. Output characteristics

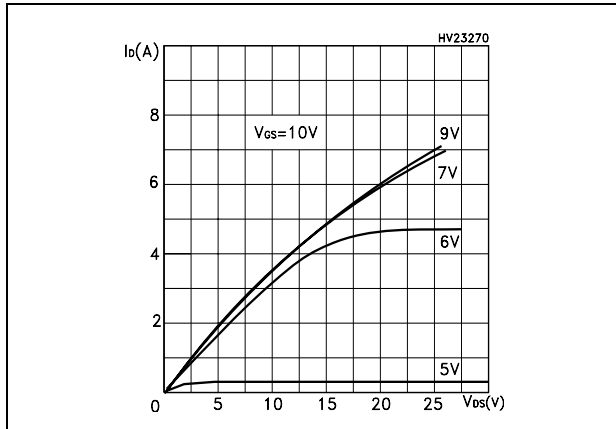

Figure 9. Transfer characteristics

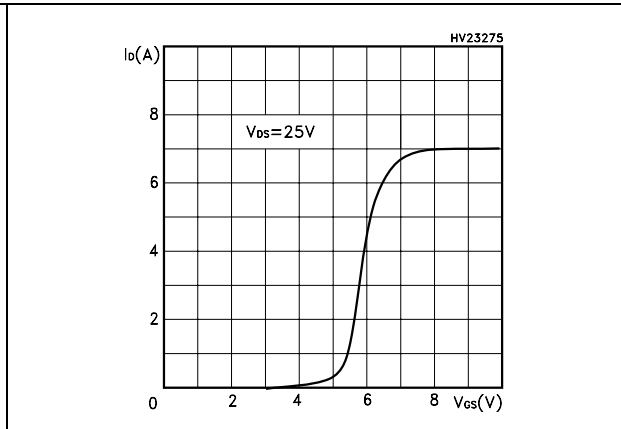

Figure 10. Transconductance

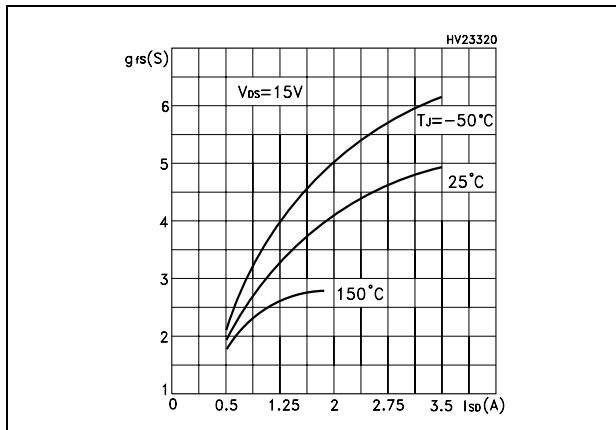

Figure 11. Static drain-source on resistance

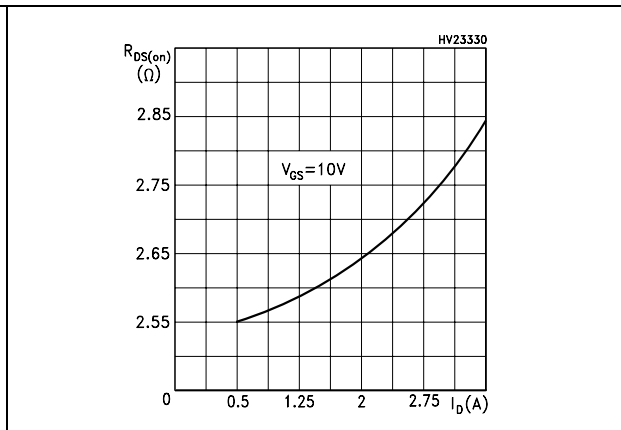

Figure 12. Gate charge vs gate-source voltage

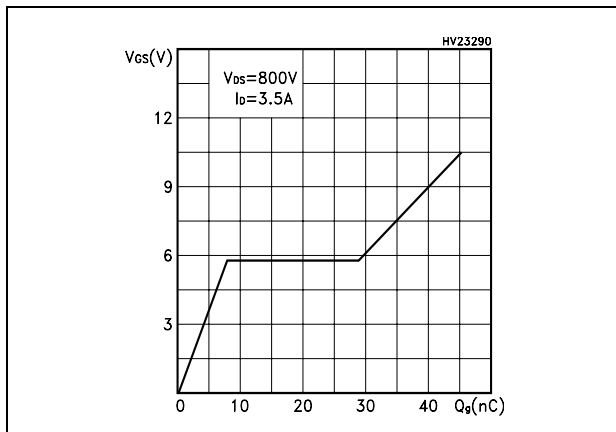

Figure 13. Capacitance variations

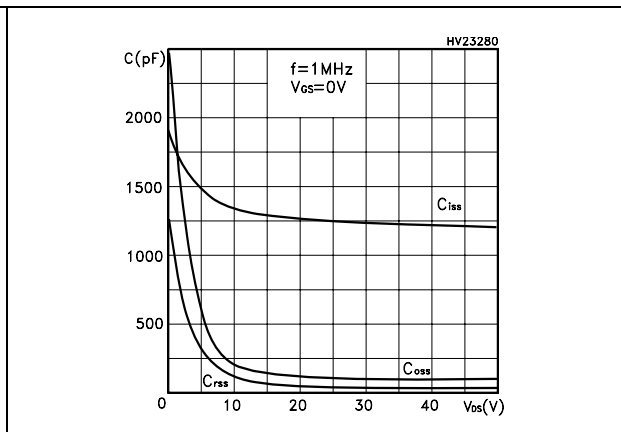

Figure 14. Normalized gate threshold voltage vs temperature

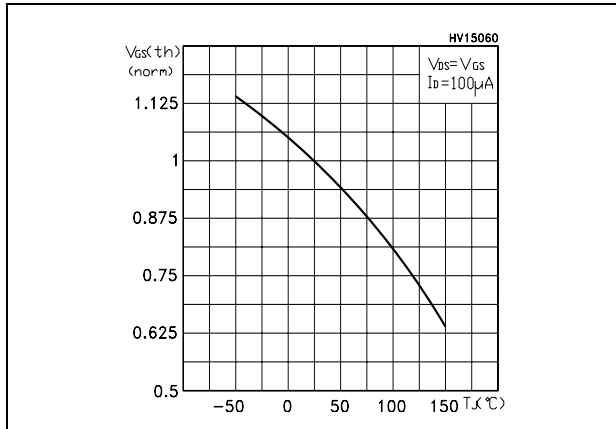

Figure 15. Normalized on resistance vs temperature

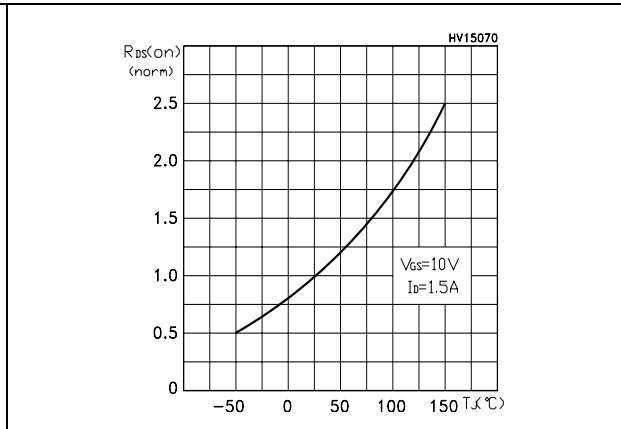

Figure 16. Source-drain diode forward characteristics

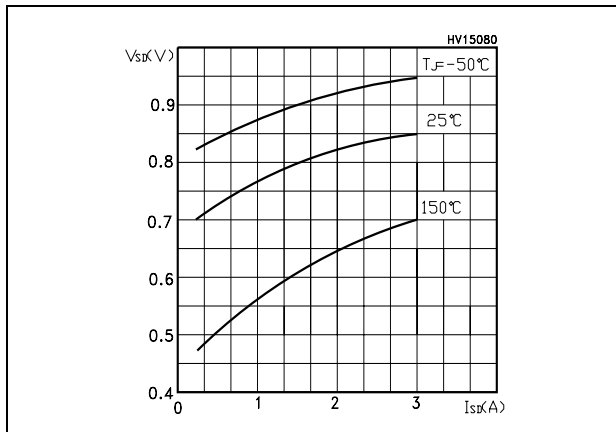

Figure 17. Normalized BVdss vs temperature

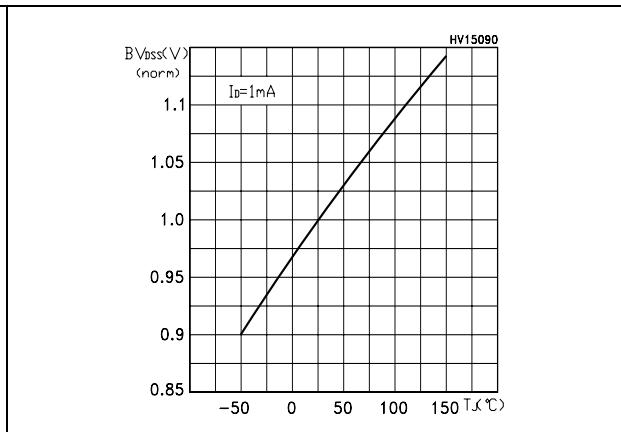
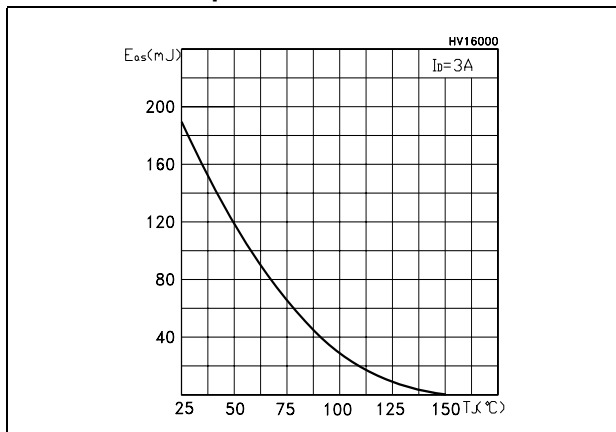

Figure 18. Maximum avalanche energy vs temperature



### 3 Test circuits

Figure 19. Unclamped inductive load test circuit

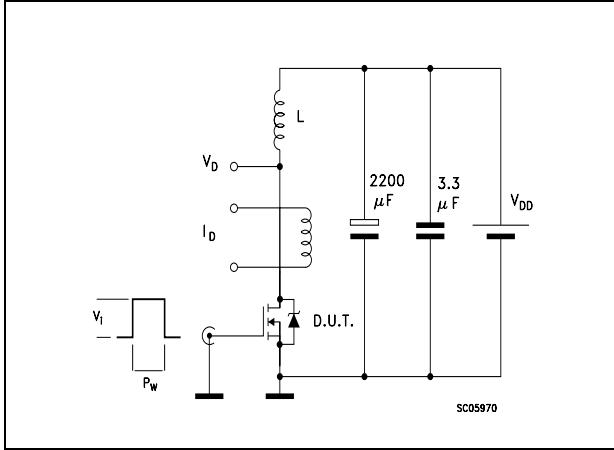

Figure 20. Unclamped inductive waveform

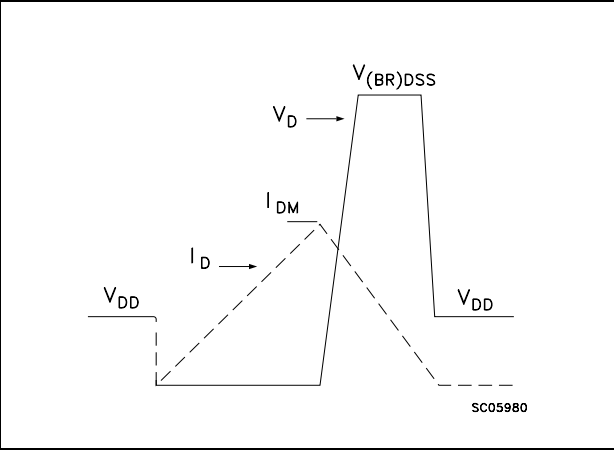

Figure 21. Switching times test circuit for resistive load

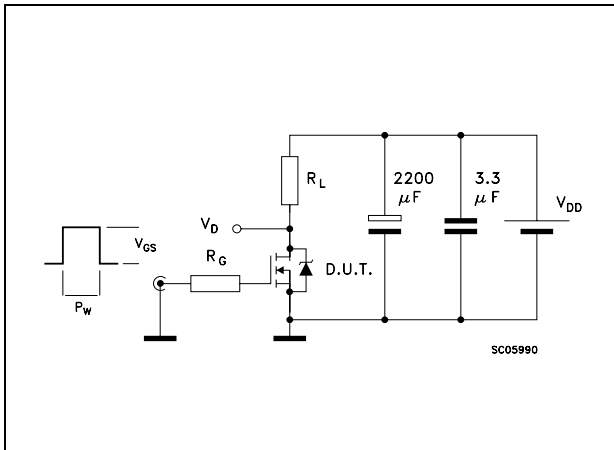

Figure 22. Gate charge test circuit

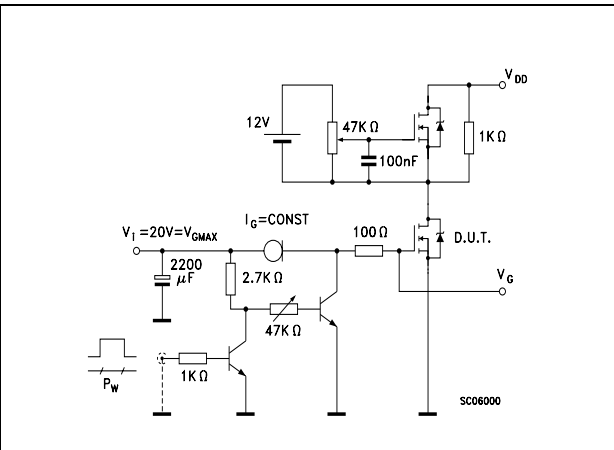
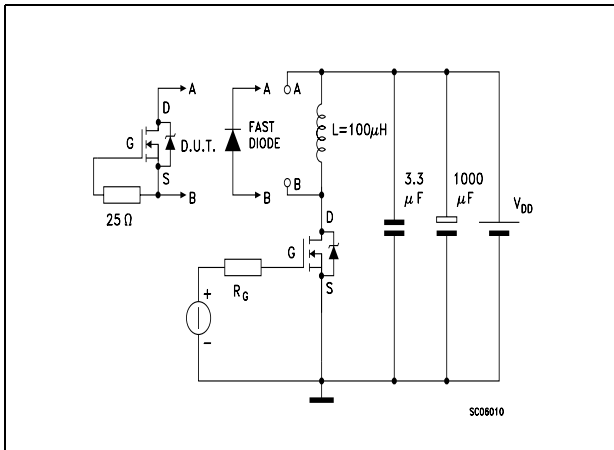

Figure 23. Test circuit for inductive load switching and diode recovery times



## 4 Package mechanical data

In order to meet environmental requirements, ST offers these devices in different grades of ECOPACK<sup>®</sup> packages, depending on their level of environmental compliance. ECOPACK<sup>®</sup> specifications, grade definitions and product status are available at: [www.st.com](http://www.st.com). ECOPACK is an ST trademark.

TO-220FP mechanical data

Dim.	mm		
	Min.	Typ.	Max.
A	4.4		4.6
B	2.5		2.7
D	2.5		2.75
E	0.45		0.7
F	0.75		1
F1	1.15		1.70
F2	1.15		1.5
G	4.95		5.2
G1	2.4		2.7
H	10		10.4
L2		16	
L3	28.6		30.6
L4	9.8		10.6
L5	2.9		3.6
L6	15.9		16.4
L7	9		9.3
Dia	3		3.2

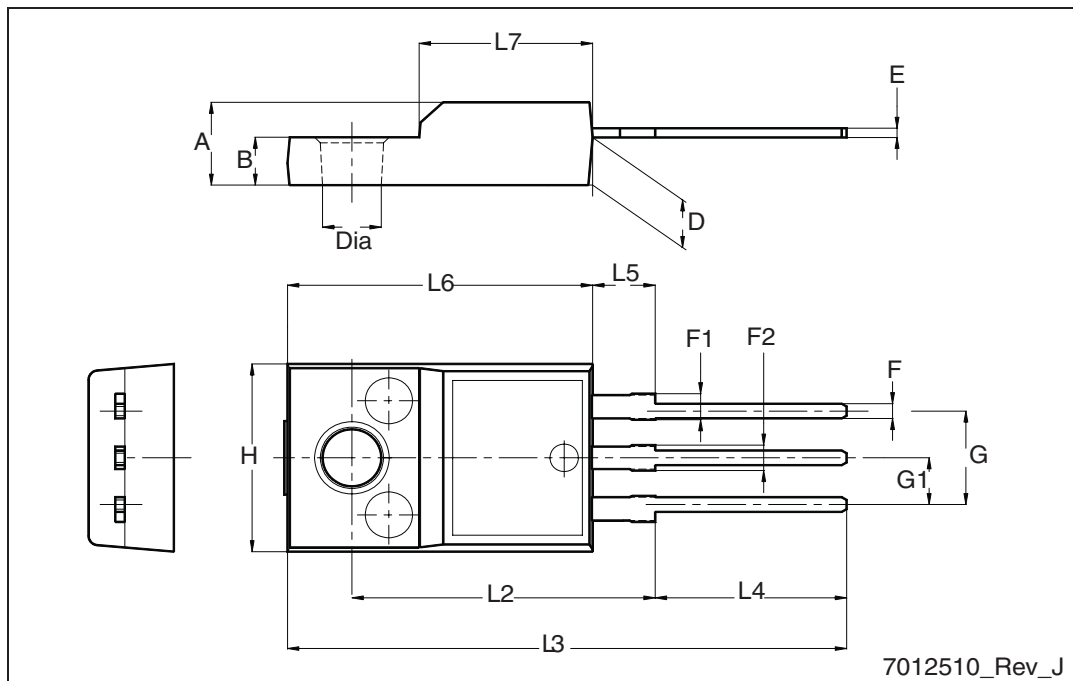

7012510\_Rev\_J

TO-220 mechanical data

Dim	mm			inch		
	Min	Typ	Max	Min	Typ	Max
A	4.40		4.60	0.173		0.181
b	0.61		0.88	0.024		0.034
b1	1.14		1.70	0.044		0.066
c	0.48		0.70	0.019		0.027
D	15.25		15.75	0.6		0.62
D1		1.27			0.050	
E	10		10.40	0.393		0.409
e	2.40		2.70	0.094		0.106
e1	4.95		5.15	0.194		0.202
F	1.23		1.32	0.048		0.051
H1	6.20		6.60	0.244		0.256
J1	2.40		2.72	0.094		0.107
L	13		14	0.511		0.551
L1	3.50		3.93	0.137		0.154
L20		16.40			0.645	
L30		28.90			1.137	
∅P	3.75		3.85	0.147		0.151
Q	2.65		2.95	0.104		0.116

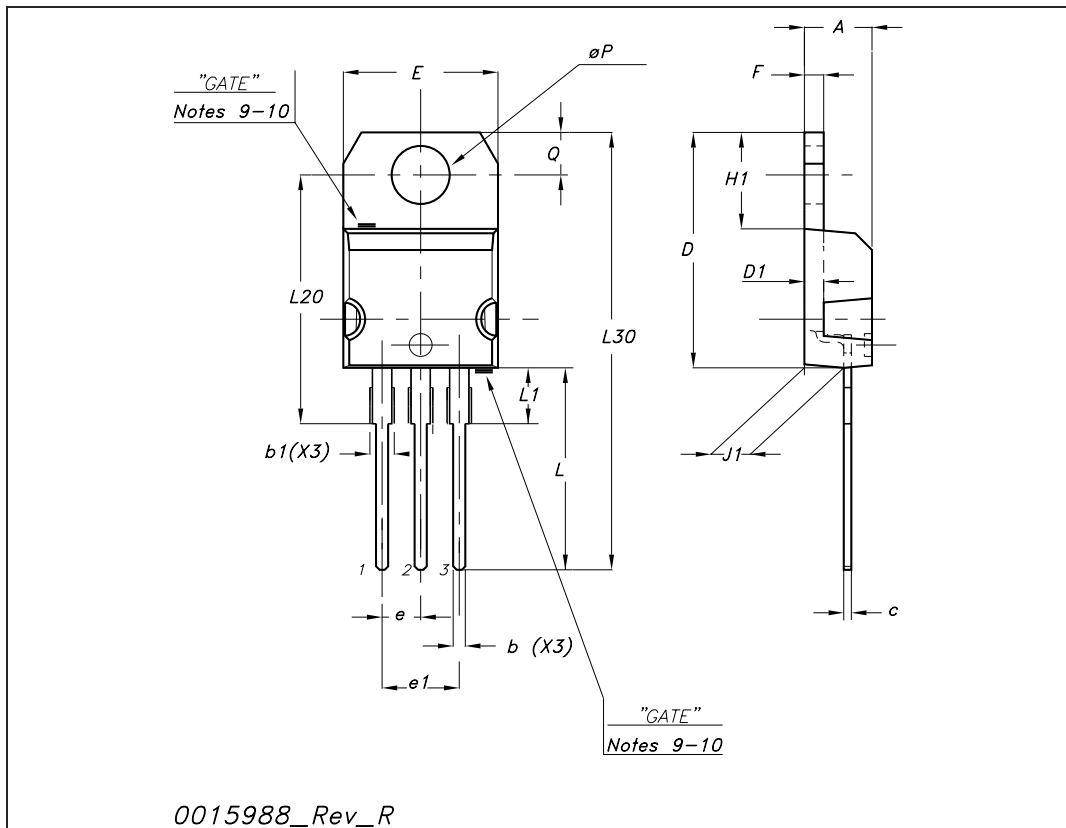

## TO-247 Mechanical data

Dim.	mm.		
	Min.	Typ	Max.
A	4.85		5.15
A1	2.20		2.60
b	1.0		1.40
b1	2.0		2.40
b2	3.0		3.40
c	0.40		0.80
D	19.85		20.15
E	15.45		15.75
e		5.45	
L	14.20		14.80
L1	3.70		4.30
L2		18.50	
øP	3.55		3.65
øR	4.50		5.50
S		5.50	

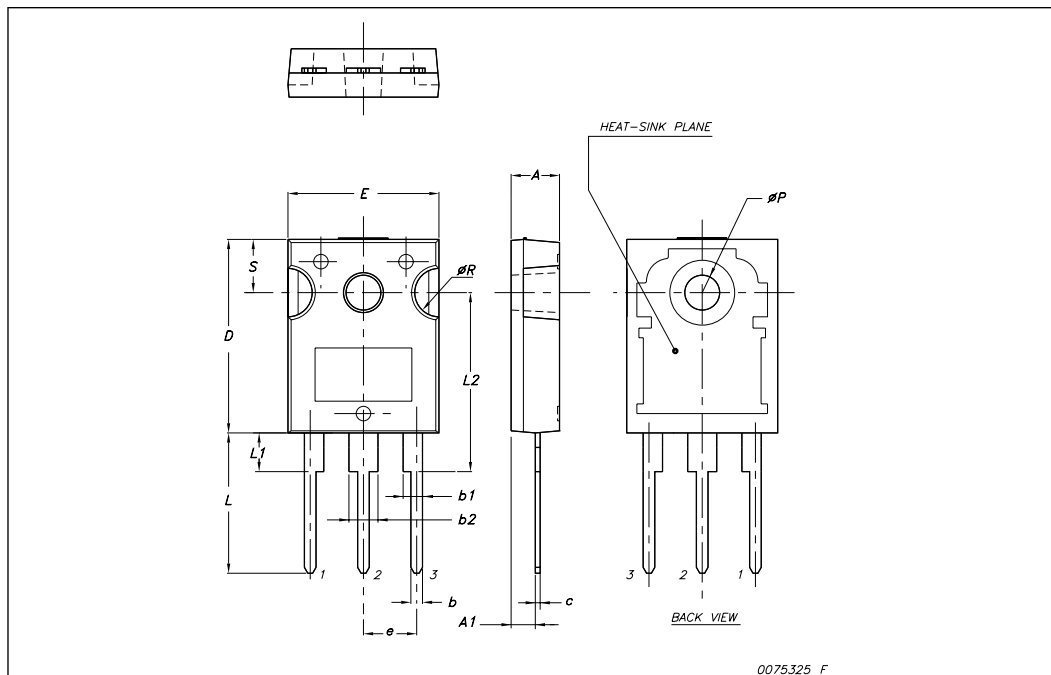

## 5 Revision history

**Table 9. Document revision history**

Date	Revision	Changes
12-Oct-2004	1	First release
08-Sep-2005	2	Complete datasheet
16-Dec-2005	3	Inserted ecopack indication
16-Aug-2006	4	New template, no content change
15-May-2009	5	Modified: <a href="#">Section 2.1: Electrical characteristics (curves)</a>

**Please Read Carefully:**

Information in this document is provided solely in connection with ST products. STMicroelectronics NV and its subsidiaries ("ST") reserve the right to make changes, corrections, modifications or improvements, to this document, and the products and services described herein at any time, without notice.

All ST products are sold pursuant to ST's terms and conditions of sale.

Purchasers are solely responsible for the choice, selection and use of the ST products and services described herein, and ST assumes no liability whatsoever relating to the choice, selection or use of the ST products and services described herein.

No license, express or implied, by estoppel or otherwise, to any intellectual property rights is granted under this document. If any part of this document refers to any third party products or services it shall not be deemed a license grant by ST for the use of such third party products or services, or any intellectual property contained therein or considered as a warranty covering the use in any manner whatsoever of such third party products or services or any intellectual property contained therein.

**UNLESS OTHERWISE SET FORTH IN ST'S TERMS AND CONDITIONS OF SALE ST DISCLAIMS ANY EXPRESS OR IMPLIED WARRANTY WITH RESPECT TO THE USE AND/OR SALE OF ST PRODUCTS INCLUDING WITHOUT LIMITATION IMPLIED WARRANTIES OF MERCHANTABILITY, FITNESS FOR A PARTICULAR PURPOSE (AND THEIR EQUIVALENTS UNDER THE LAWS OF ANY JURISDICTION), OR INFRINGEMENT OF ANY PATENT, COPYRIGHT OR OTHER INTELLECTUAL PROPERTY RIGHT.**

**UNLESS EXPRESSLY APPROVED IN WRITING BY AN AUTHORIZED ST REPRESENTATIVE, ST PRODUCTS ARE NOT RECOMMENDED, AUTHORIZED OR WARRANTED FOR USE IN MILITARY, AIR CRAFT, SPACE, LIFE SAVING, OR LIFE SUSTAINING APPLICATIONS, NOR IN PRODUCTS OR SYSTEMS WHERE FAILURE OR MALFUNCTION MAY RESULT IN PERSONAL INJURY, DEATH, OR SEVERE PROPERTY OR ENVIRONMENTAL DAMAGE. ST PRODUCTS WHICH ARE NOT SPECIFIED AS "AUTOMOTIVE GRADE" MAY ONLY BE USED IN AUTOMOTIVE APPLICATIONS AT USER'S OWN RISK.**

Resale of ST products with provisions different from the statements and/or technical features set forth in this document shall immediately void any warranty granted by ST for the ST product or service described herein and shall not create or extend in any manner whatsoever, any liability of ST.

ST and the ST logo are trademarks or registered trademarks of ST in various countries.

Information in this document supersedes and replaces all information previously supplied.

The ST logo is a registered trademark of STMicroelectronics. All other names are the property of their respective owners.

© 2009 STMicroelectronics - All rights reserved

STMicroelectronics group of companies



Australia - Belgium - Brazil - Canada - China - Czech Republic - Finland - France - Germany - Hong Kong - India - Israel - Italy - Japan - Malaysia - Malta - Morocco - Philippines - Singapore - Spain - Sweden - Switzerland - United Kingdom - United States of America

[www.st.com](http://www.st.com)



## Looking for pricing, stock, or lifecycle information?

Click below to explore more details on WIN SOURCE:

-  [View F5NK100Z on WIN SOURCE](#)
-  [STMicroelectronics Information](#)

## Optimize Your Supply Chain with WIN SOURCE Solutions

-  Global Sourcing Solution
-  Obsolete Management
-  Cost Control Management
-  Shortage Management
-  Alternative Solution
-  Excess Inventory Management