

FAN1581

5A Adjustable/Fixed Ultra Low Dropout Linear Regulator

Features

- Ultra Low dropout voltage, 0.4V typical at 5A
- 1.2V Versions available for GTL termination
- Remote sense operation
- Fast transient response
- Load regulation: 0.05% typical
- 0.5% typical initial accuracy
- On-chip thermal limiting
- TO-263, TO-252 and TO-220 packages

Applications

- Support of GTL+ bus supply
- Low voltage logic supply
- Embedded Processor supplies
- Split plane regulator
- 2.5V, and 1.8V Logic Families
- DDR Termination Supply

Description

The FAN1581, FAN1581-1.2, FAN1581-1.5, and FAN1581-2.5 are ultra-low dropout regulators with 5A output current capability. These devices have been optimized for low voltage applications including V_{TT} bus termination, where transient response and minimum input voltage are critical. The FAN1581 is ideal for low voltage microprocessor applications requiring a regulated output from 1.3V to 5.7V with a power input supply of 1.75V to 6.5V. The FAN1581-1.5 offers fixed 1.5V with 5A current capabilities for GTL+ bus V_{TT} termination. Additionally, the FAN1581-1.2 offers fixed 1.2V output for CPU Bus termination. The FAN1581-2.5 offers fixed 2.5V with 5A current capability for logic IC operation and processors while minimizing the overall power dissipation.

Current limit ensures controlled short-circuit current. On-chip thermal limiting provides protection against any combination of overload and ambient temperature that would create excessive junction temperatures.

The FAN1581 series regulators are available in the 5-pin TO-263, TO-252 and TO-220 packages.

Typical Applications

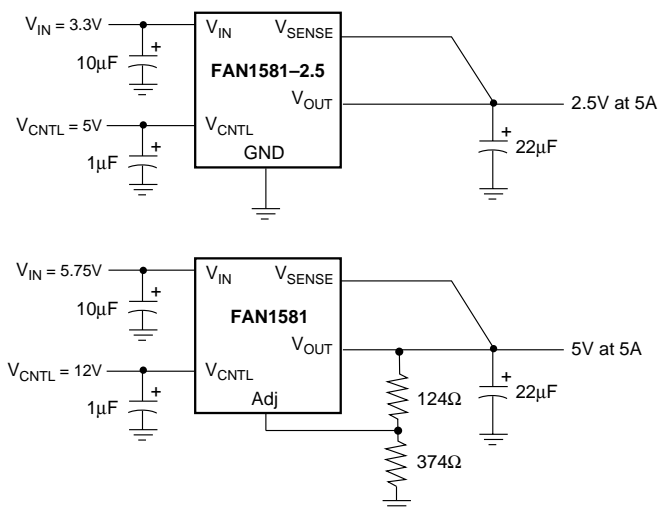
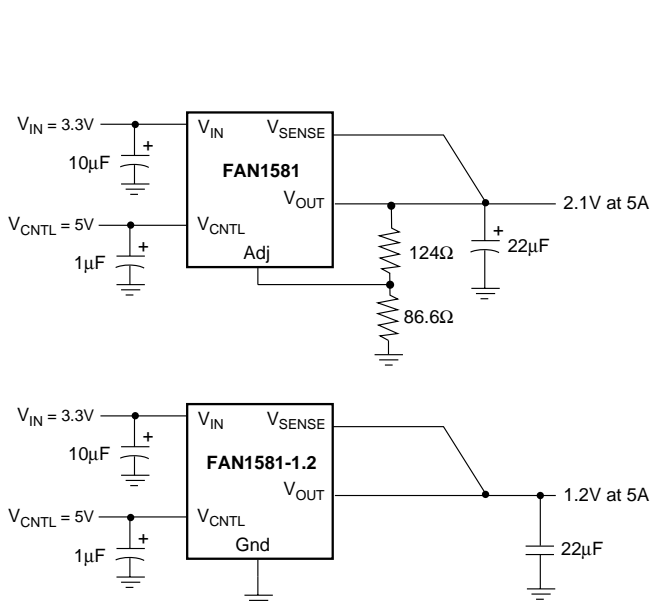

Pin Assignments

FAN1581M-1.2, -1.5, -2.5

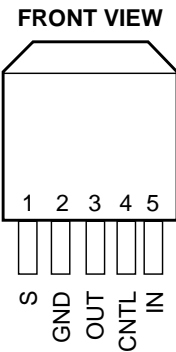

FAN1581M

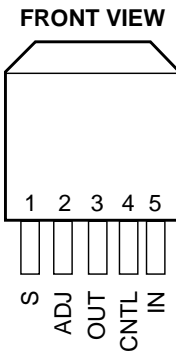

5-Lead Plastic TO-263
 $\theta_{JC}=3^{\circ}\text{C/W}^*$
 Tab is out.

FAN1581D

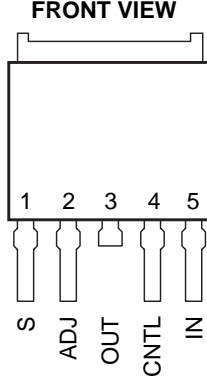

FAN1581D-1.2, -1.5, -2.5

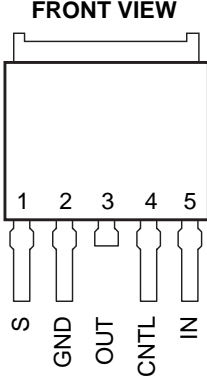

5-Lead Plastic TO-252 DPAK
 $\theta_{JC}=3^{\circ}\text{C/W}^*$
 Tab is out.

FAN1581T

FRONT VIEW

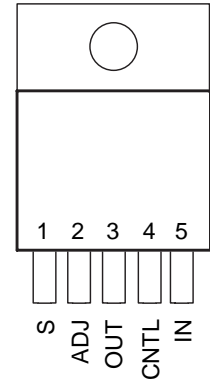

5-Lead TO-220
 $\theta_{JC}=3^{\circ}\text{C/W}^*$ Tab is VOUT.

*With package soldered to 0.5 square inch copper area over backside ground plane or internal power plane, θ_{JA} can vary from 30 °C/W to more than 40 °C/W. Other mounting techniques can provide a thermal resistance lower than 30 °C/W.

Pin Definitions

Pin Number	Pin Name	Pin Function Description
1	VSense	Remote Voltage Sense. Connect this pin to the load to permit true remote sensing and avoid trace drops.
2	ADJ/GND	Adjust or Ground. On the FAN1581, this pin forms the feedback to determine the output voltage. On the FAN1581-1.2, -1.5 and -2.5, connect this pin to ground.
3	VOUT	Output Voltage. This pin and the tab are output.
4	VCNTL	Control Voltage. This pin draws small-signal power to control the FAN1581 circuitry. Connect to a voltage higher than VIN, as shown in the applications circuits.
5	VIN	Input Voltage.

Internal Block Diagram

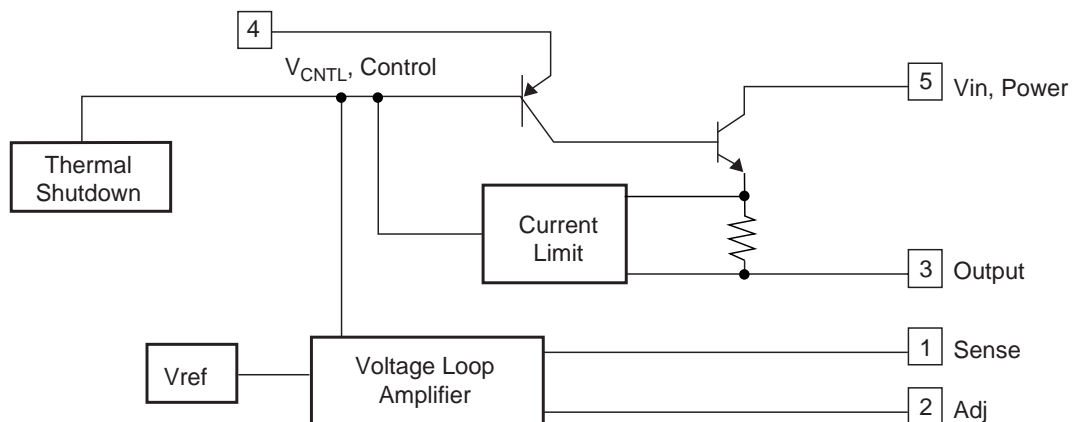

Absolute Maximum Ratings

Parameter	Min.	Max.	Unit
V_{IN}		7	V
V_{CNTL}		13.2	V
Operating Junction Temperature Range	0	125	°C
Lead Temperature (Soldering, 10 sec.)		300	°C
Storage Temperature Range	-65	150	°C

Electrical Characteristics

$T_J=25^{\circ}\text{C}$, $V_{OUT} = V_{SENSE}$, $V_{ADJ} = 0\text{V}$ unless otherwise specified.

The • denotes specifications which apply over the specified operating temperature range.

Parameter	Conditions	Min.	Typ.	Max.	Units
Reference Voltage ³	$2.05\text{V} \leq V_{IN} \leq 5.5\text{V}$, $2.7\text{V} \leq V_{CNTL} \leq 12\text{V}$, $10\text{mA} \leq I_{OUT} \leq 5\text{A}$	• 1.237	1.250	1.263	V
Adjustable Output Voltage	$3\text{V} \leq V_{IN} \leq 7\text{V}$ (function of V_{out}), $10\text{mA} \leq I_{OUT} \leq 5\text{A}$	• V_{ref}	1.5	5.7	V
Output Voltage ⁴	$3\text{V} \leq V_{IN} \leq 7\text{V}$, $10\text{mA} \leq I_{OUT} \leq 5\text{A}$	• 1.47	1.5	1.53	V
Output Voltage ⁵	$4\text{V} \leq V_{IN} \leq 7\text{V}$, $10\text{mA} \leq I_{OUT} \leq 5\text{A}$	• 2.474	2.5	2.526	V
Output Voltage ⁶	$2.7\text{V} \leq V_{IN} \leq 7\text{V}$, $10\text{mA} \leq I_{OUT} \leq 5\text{A}$	• 1.176	1.200	1.224	V
Line Regulation ^{1,2}	$1.75\text{V} \leq V_{IN} \leq 5.5\text{V}$, $2.5\text{V} \leq V_{CNTL} \leq 12\text{V}$, $I_{OUT} = 10\text{mA}$	•	1	3	mV
Load Regulation ^{1,2}	$V_{IN} = 2.1\text{V}$, $V_{CNTL} = 2.75\text{V}$, $10\text{mA} \leq I_{OUT} \leq 5\text{A}$	•	1	5	mV
Dropout Voltage Minimum ($V_{CNTL}-V_{OUT}$)	$V_{IN} = 2.05\text{V}$, $\Delta V_{REF} = 1\%$, $I_{OUT} = 5\text{A}$	•	1.05	1.18	V
Dropout Voltage Minimum ($V_{IN}-V_{OUT}$)	$V_{CNTL} = 2.75\text{V}$, $\Delta V_{REF} = 1\%$, $I_{OUT} = 5\text{A}$		0.4	0.5	V
Dropout Voltage Minimum V_{IN}	$V_{CNTL} = 2.75\text{V}$, $\Delta V_{REF} = 1\%$, $I_{OUT} = 5\text{A}$	•	0.5	0.6	V
Current Limit	$V_{IN} = 2.05\text{V}$, $V_{CNTL} = 2.75\text{V}$	• 5.2			A
Control Pin Current	$V_{IN} = 2.05\text{V}$, $V_{CNTL} = 2.75\text{V}$, $I_{OUT} = 10\text{mA}$	•	3	6	mA
Adjust Pin Current ³	$V_{IN} = 2.05\text{V}$, $V_{CNTL} = 2.75\text{V}$	•	50	120	μA
Minimum Load Current	$V_{IN} = 3.3\text{V}$, $V_{CNTL} = 5\text{V}$	•	5.0	10	mA
Ripple Rejection	$V_{IN} = 3.75\text{V}$, $V_{CNTL} = 3.75\text{V}$, $f = 120\text{Hz}$, $C_{OUT} = 22\mu\text{F}$ Tantalum, $I_{OUT} = 2.5\text{A}$		60	80	dB
Thermal Resistance, Junction to Case	TO-263 SPAK		3 2		°C/W
Thermal Regulation	$T_A = 25^{\circ}\text{C}$, 30ms pulse		0.002	0.02	%/W
Thermal Shutdown			150		°C

Notes:

- See thermal regulation specifications for changes in output voltage due to heating effects. Load and line regulation are measured at a constant junction temperature by low duty cycle pulse testing.
- Line and load regulation are guaranteed up to the maximum power dissipation (18W). Power dissipation is determined by input/output differential and the output current. Guaranteed maximum output power will not be available over the full input/output voltage range.
- FAN1581 only.
- FAN1581-1.5 only.
- FAN1581-2.5 only.
- FAN1581-1.2 only.

Typical Performance Characteristics

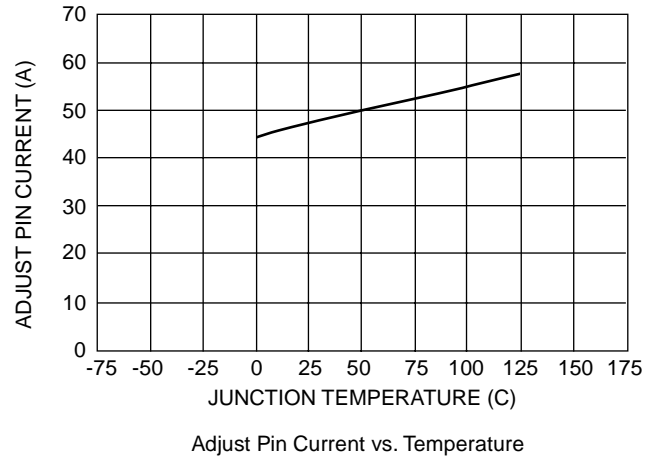
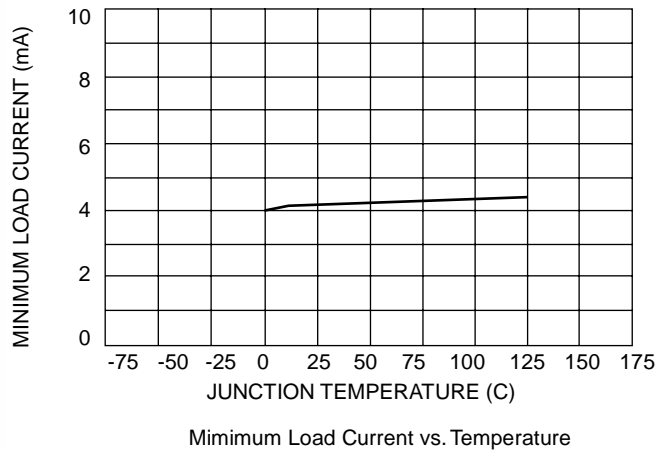
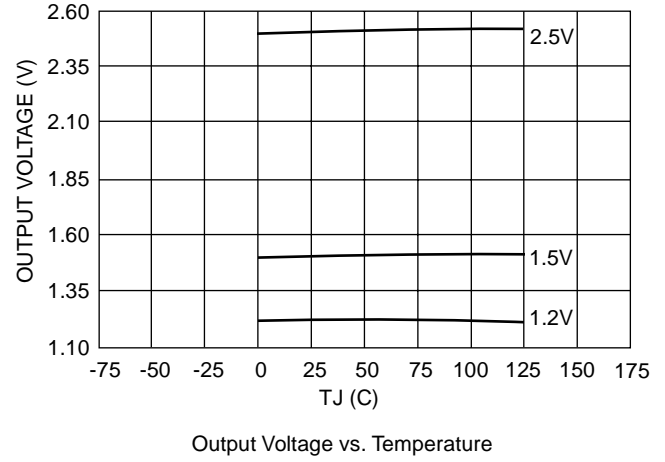
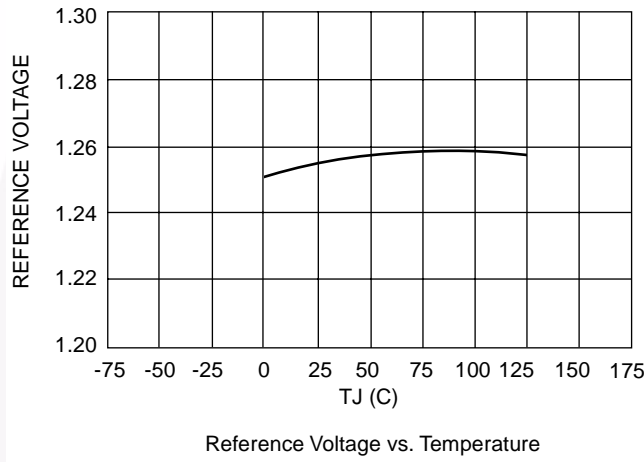
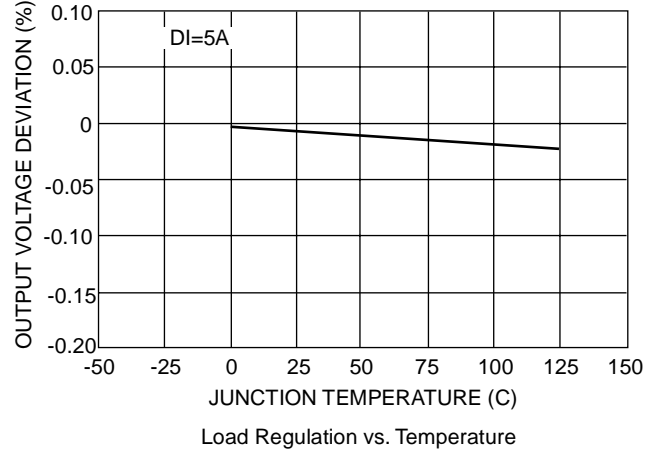
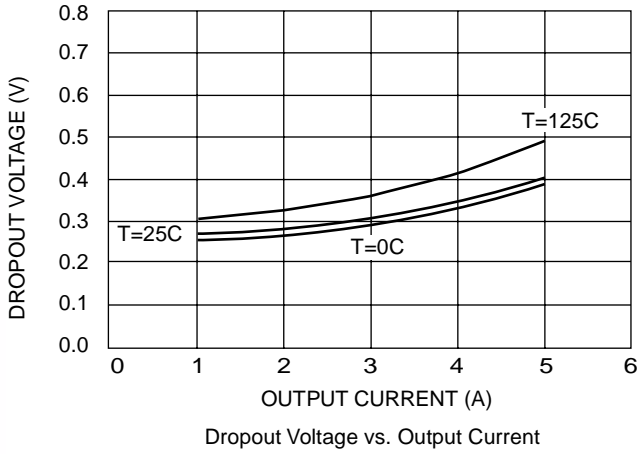

Typical Performance Characteristics (continued)

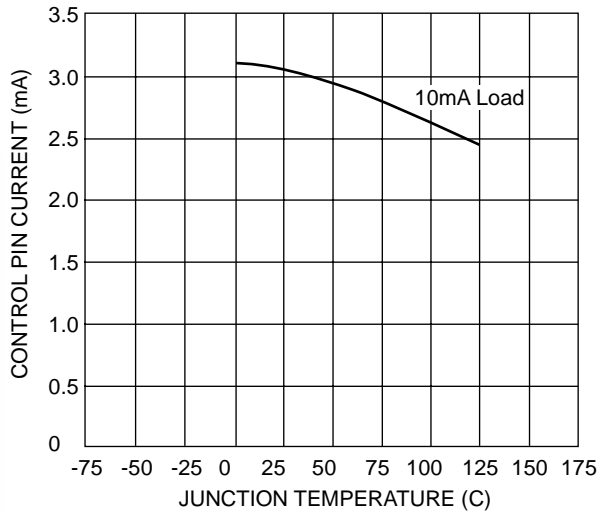

Control Pin Current vs. Temperature

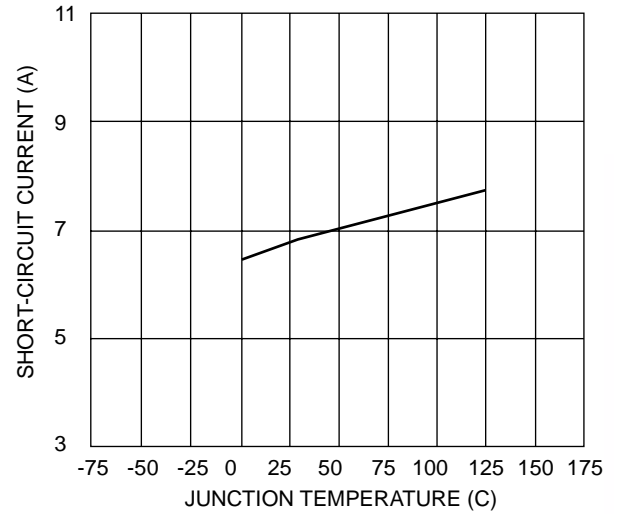

Short-Circuit Current vs. Temperature

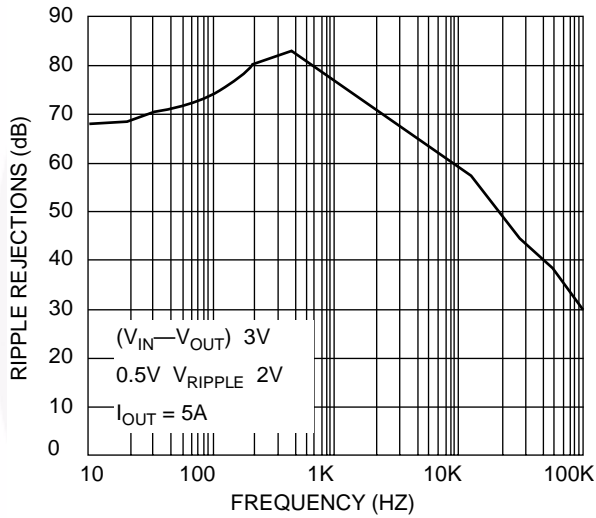

Ripple Rejection vs. Frequency

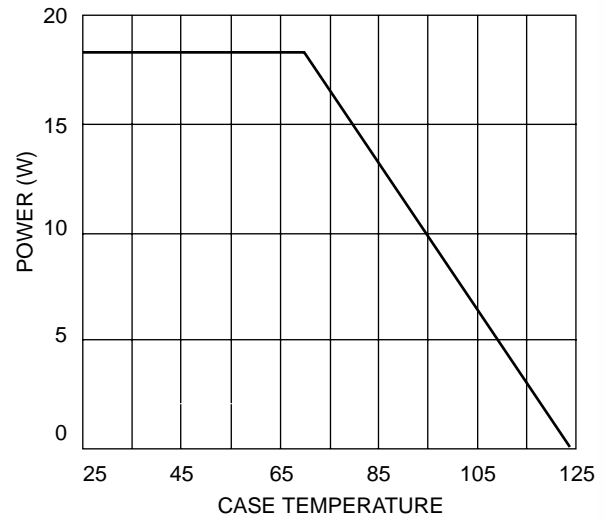

Maximum Power Dissipation

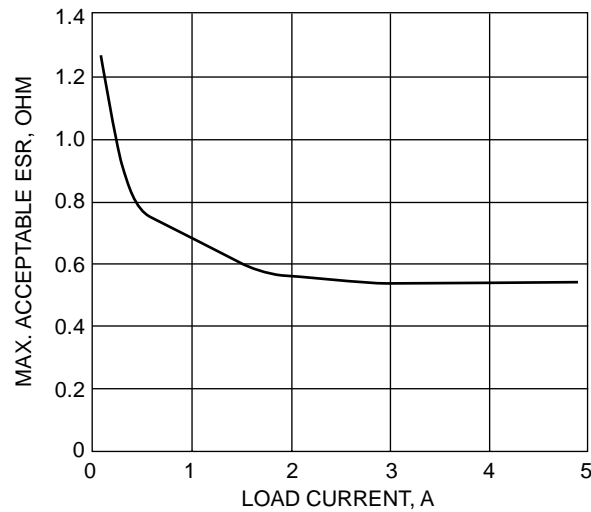

FAN1581 Stability

General

The FAN1581, FAN1581-1.2, FAN1581-1.5, and FAN1581-2.5 are three-terminal regulators optimized for DDR and GTL+ V_{TT} termination and logic applications. These devices are short-circuit protected, and offer thermal shutdown to turn off the regulator when the junction temperature exceeds about 150°C. The FAN1581 series provides low dropout voltage and fast transient response. Frequency compensation uses capacitors with low ESR while still maintaining stability. This is critical in addressing the needs of low voltage high speed microprocessor buses like GTL+.

V_{IN} and V_{CNTL} Functions

The FAN1581 utilizes a dual supply approach to maximize efficiency. The collector of the power device is brought out to the V_{IN} pin to minimize internal power dissipation under high current loads. V_{CNTL} provides power for the control circuitry and the drive for the output NPN transistor. V_{CNTL} should be at least 1.2V higher than the output voltage. Special care was taken to ensure there are no supply-sequencing problems. The output voltage will not turn on until both supplies are operating. If the control voltage comes up first, the output current will be typically limited to about 3.0mA until the power input voltage comes up. If the power input voltage comes up first the output will not turn on at all until the control voltage comes up. The output can never come up unregulated.

The FAN1581 can also be used as a single supply device with the control and power inputs tied together. In this mode, the dropout is determined by the minimum control voltage.

Stability

The FAN1581 series requires an output capacitor as a part of the frequency compensation. It is recommended to use a 22 μ F solid tantalum or a 100 μ F aluminum electrolytic on the output to ensure stability. The frequency compensation of these devices optimizes the frequency response with low ESR capacitors. In general, it is suggested to use capacitors with an ESR of < 0.3 Ω . It is also recommended to use bypass capacitors such as a 22 μ F tantalum or a 100 μ F aluminum on the adjust pin of the FAN1581 for low ripple and fast transient response. When these bypassing capacitors are not used at the adjust pin, smaller values of output capacitors provide equally good results. A graph showing stability of output capacitance ESR vs. load current can be found under Typical Performance Characteristics.

Protection Diodes

In normal operation, the FAN1581 series does not require any protection diodes. For the FAN1581, internal resistors limit internal current paths on the adjust pin. Therefore, even with bypass capacitors on the adjust pin, no protection diode is needed to ensure device safety under short-circuit conditions.

A protection diode between the input and output pins is usually not needed. An internal diode between the input and the output pins on the FAN1581 series can handle microsecond surge currents of 50A to 100A. Even with large value output capacitors it is difficult to obtain those values of surge currents in normal operation. Only with large values of output capacitance, such as 1000 μ F to 5000 μ F, and with the input pin instantaneously shorted to ground can damage occur. A crowbar circuit at the input can generate those levels of current; a diode from output to input is then recommended, as shown in Figure 1. Usually, normal power supply cycling or system “hot plugging and unplugging” will not generate current large enough to do any damage.

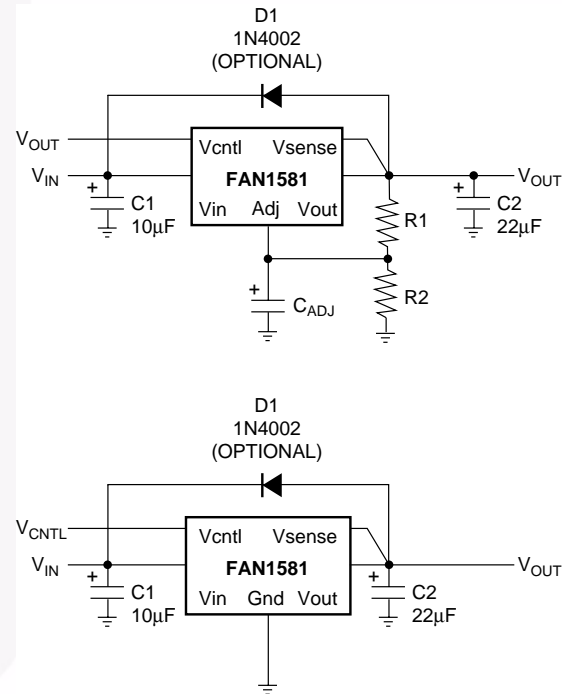

Figure 1. Optional Protection Diode

Ripple Rejection

In applications that require improved ripple rejection, a bypass capacitor from the adjust pin of the FAN1581 to ground reduces the output ripple by the ratio of $V_{OUT}/1.25V$. The impedance of the adjust pin capacitor at the ripple frequency should be less than the value of R1 (typically in the range of 100 Ω to 120 Ω) in the feedback divider network in Figure 1. Therefore, the value of the required adjust pin capacitor is a function of the input ripple frequency. For example, if R1 equals 100 Ω and the ripple frequency equals 120Hz, the adjust pin capacitor should be 22 μ F. At 10kHz, only 0.22 μ F is needed.

Output Voltage

The FAN1581 regulator develops a 1.25V reference voltage between the output pin and the adjust pin (see Figure 2). Placing a resistor R1 between these two terminals causes a constant current to flow through R1 and down through R2 to set the overall output voltage. Normally, this current is the specified minimum load current of 10mA.

The current out of the adjust pin adds to the current from R1 and is typically 50µA. Its output voltage contribution is small and only needs consideration when a very precise output voltage setting is required.

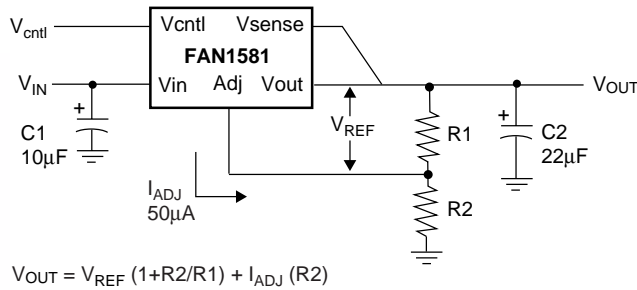

Figure 2. Basic Regulator Circuit

Load Regulation

The FAN1581 family provides true remote sensing, eliminating output voltage errors due to trace resistance. To utilize remote sensing, connect the VSENSE pin directly to the load, rather than at the VOUT pin. If the load is more than 1" away from the FAN1581, it may be necessary to increase the load capacitance to ensure stability.

Thermal Considerations

The FAN1581 series protect themselves under overload conditions with internal power and thermal limiting circuitry. However, for normal continuous load conditions, do not exceed maximum junction temperature ratings. It is important to consider all sources of thermal resistance from junction-to-ambient. These sources include the junction-to-case resistance, the case-to-heat sink interface resistance, and the heat sink resistance. Thermal resistance specifications have been developed to more accurately reflect device temperature and ensure safe operating temperatures. The electrical characteristics section provides a separate thermal resistance and

maximum junction temperature for both the control circuitry and the power transistor. Calculate the maximum junction temperature for both sections to ensure that both thermal limits are met.

For example, look at using an FAN1581M-1.5 to generate 5A @ 1.5V ± 2% from a 3.3V source (3.2V to 3.6V).

Assumptions:

- $V_{in} = 3.6V$ worst case
- $V_{OUT} = 1.47V$ worst case
- $I_{OUT} = 5A$ continuous
- $T_A = 40^{\circ}C$
- $\Theta_{Case-to-Ambient} = 5^{\circ}C/W$ (assuming both a heatsink and a thermally conductive material)

The power dissipation in this application is:

$$P_D = (V_{IN} - V_{OUT}) * (I_{OUT}) = (3.6 - 1.47) * (5) = 10.65W$$

From the specification table,

$$T_J = T_A + (P_D) * (\Theta_{Case-to-Ambient} + \Theta_{JC})$$

$$= 40 + (10.65) * (5 + 3) = 125^{\circ}C$$

The junction temperature is within the maximum rating.

Junction-to-case thermal resistance is specified from the IC junction to the bottom of the case directly below the die. This is the lowest resistance path for heat flow. Proper mounting ensures the best thermal flow from this area of the package to the heat sink. Use of a thermally conductive material at the case-to-heat sink interface is recommended. Use a thermally conductive spacer if the case of the device must be electrically isolated and include its contribution to the total thermal resistance.

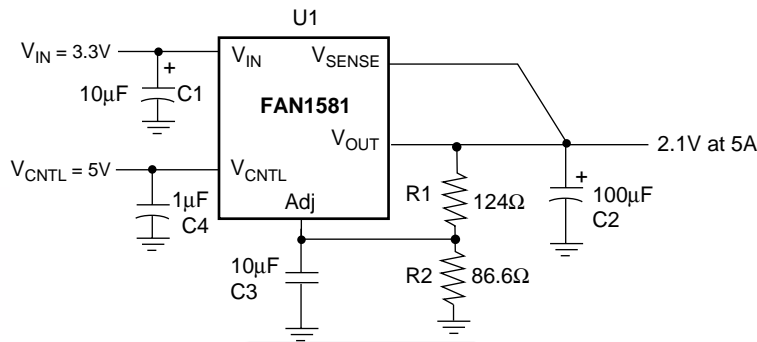

Figure 3. Application Circuit (FAN1581)

Table 1. Bill of Materials for Application Circuit for the FAN1581

Item	Quantity	Manufacturer	Part Number	Description
C1, C3	2	Xicon	L10V10	10µF, 10V Aluminum
C2	1	Xicon	L10V100	100µF, 10V Aluminum
C4	1	Any		1µF Ceramic
R1	1	Generic		124Ω, 1%
R2	1	Generic		86.6Ω, 1%
U1	1	Fairchild	FAN1581P	5A Regulator

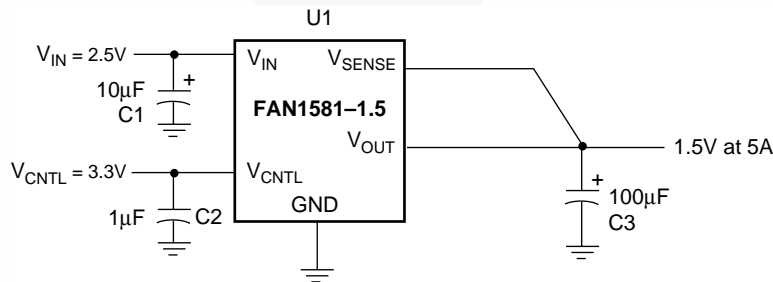

Figure 4. Application Circuit (FAN1581-1.5)

Table 2. Bill of Materials for Application Circuit for the FAN1581-1.5

Item	Quantity	Manufacturer	Part Number	Description
C1	1	Xicon	L10V10	10µF, 10V Aluminum
C2	1	Any		1µF Ceramic
C3	1	Xicon	L10V100	100µF, 10V Aluminum
U1	1	Fairchild	FAN1581P-1.5	5A Regulator

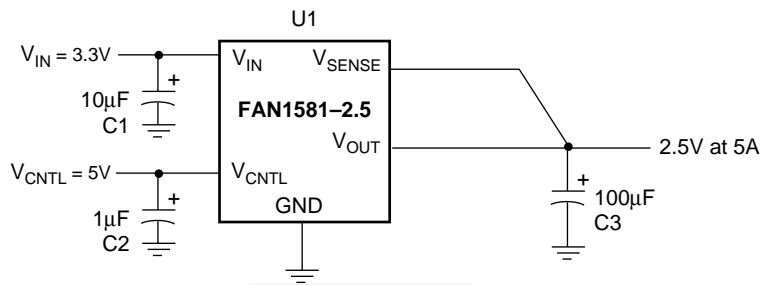

Figure 5. Application Circuit (FAN1581-2.5)

Table 3. Bill of Materials for Application Circuit for the FAN1581-2.5

Item	Quantity	Manufacturer	Part Number	Description
C1	1	Xicon	L10V10	10µF, 10V Aluminum
C2	1	Any		1µF Ceramic
C3	1	Xicon	L10V100	100µF, 10V Aluminum
U1	1	Fairchild	FAN1581P-2.5	5A Regulator

Ordering Information

Product Number	Package
FAN1581MX	TO-263 in Tape and Reel
FAN1581DX	TO-252 DPAK in Tape and Reel
FAN1581M12X	TO-263 in Tape and Reel
FAN1581D15X	TO-252 DPAK in Tape and Reel
FAN1581M25X	TO-263 in Tape and Reel
FAN1581D25X	TO-252 DPAK in Tape and Reel
FAN1581T	TO-220 in Tape and Reel

Mechanical Dimensions

5-Lead TO-263 Package

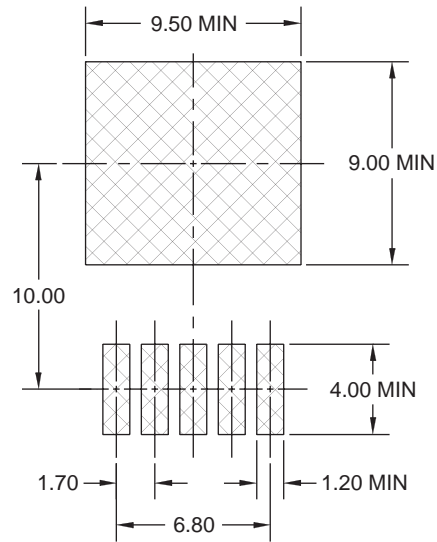
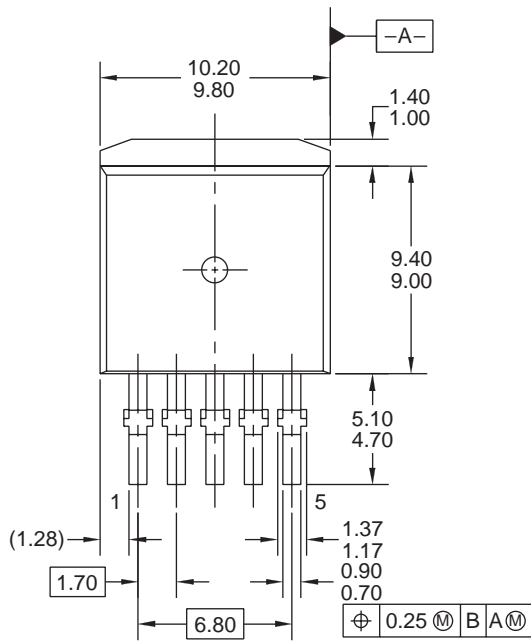

LAND PATTERN RECOMMENDATION

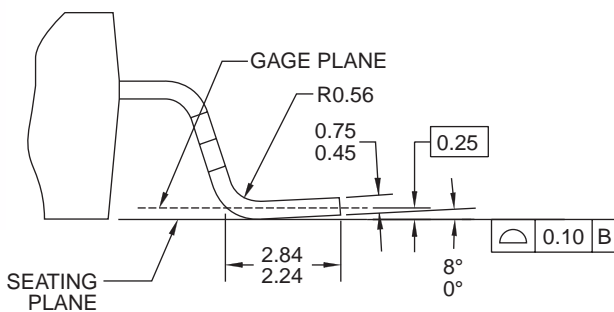
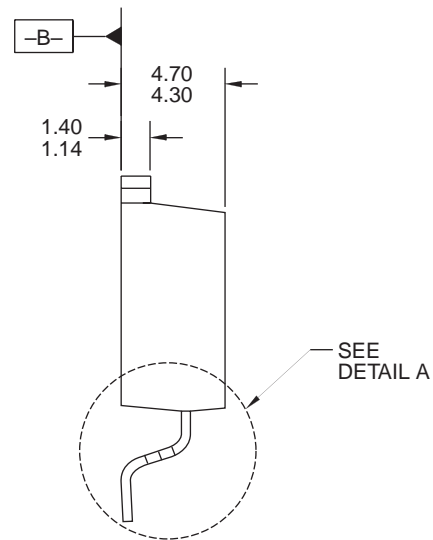
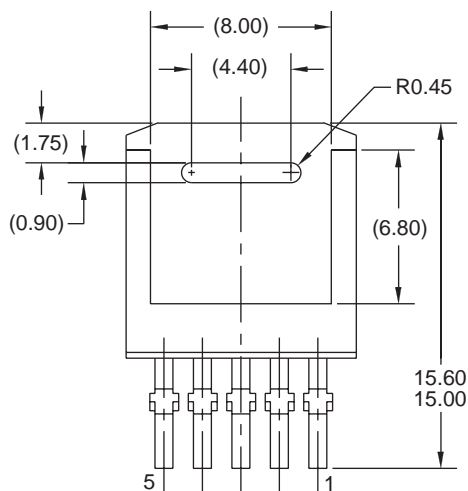

DETAIL A, ROTATED 90°

SCALE: 10X

NOTES: UNLESS OTHERWISE SPECIFIED

- A) ALL DIMENSIONS ARE IN MILLIMETERS.
- B) STANDARD LEAD FINISH: 200 MICRONS/5.08 MICROMETERS MIN. LEAD/TIN 15/85 ON COPPER.
- C) NO PACKAGE STANDARD REFERENCE AS OF JUNE 2002.
- D) DIMENSIONING AND TOLERANCING PER ANSI Y14.5M - 1982.

Mechanical Dimensions (continued)

5-Lead TO-252 Package

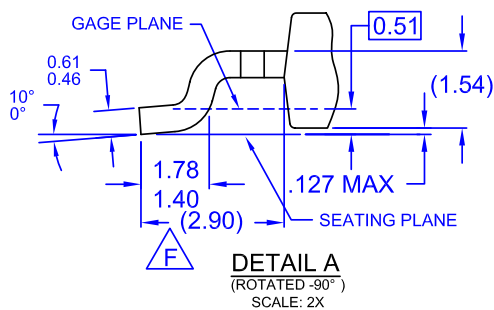
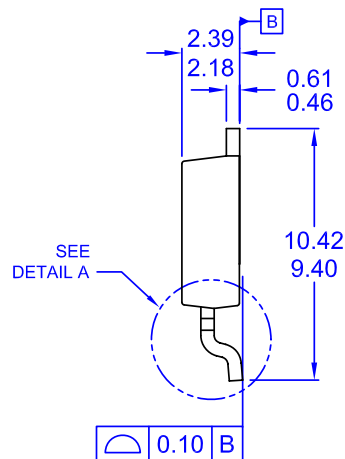
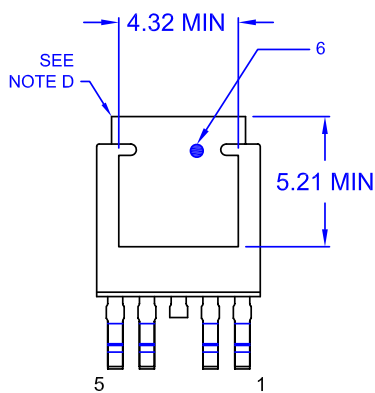
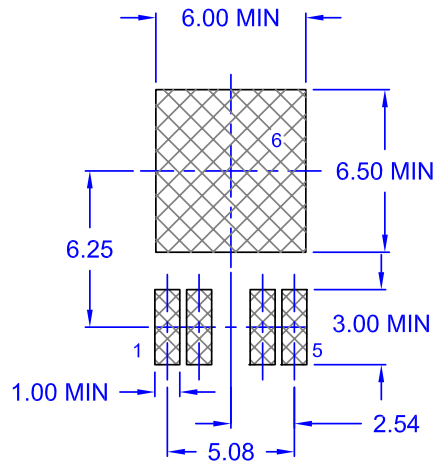
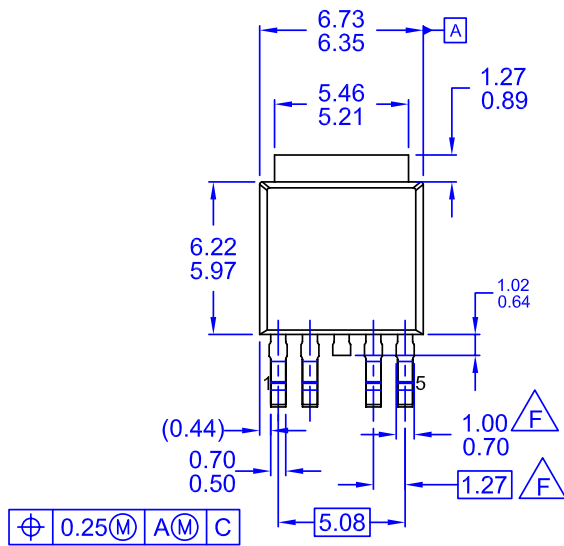

- NOTES: UNLESS OTHERWISE SPECIFIED
- A) PACKAGE REFERENCE. JEDEC TO252 VARIATION "AD" ISSUE "E". DATED JUNE 2004.
 - B) ALL DIMENSIONS ARE IN MILLIMETERS.
 - C) DIMENSIONS ARE EXCLUSIVE OF BURRS, MOLD FLASH, AND TIE BAR EXTRUSIONS.
 - D) HEAT SINK TOP EDGE COULD BE IN CHAMFERD CORNERS OR EDGE PROTRUSION.
 - E) DIMENSIONS AND TOLERANCES PER ASME Y14.5M-1994.
 - \triangle F) DOES NOT COMPLY TO JEDEC STD VALUE.
 - G) DRAWING FILE NAME: TO252A05REV3.

Mechanical Dimensions (continued)

TO-220 Package

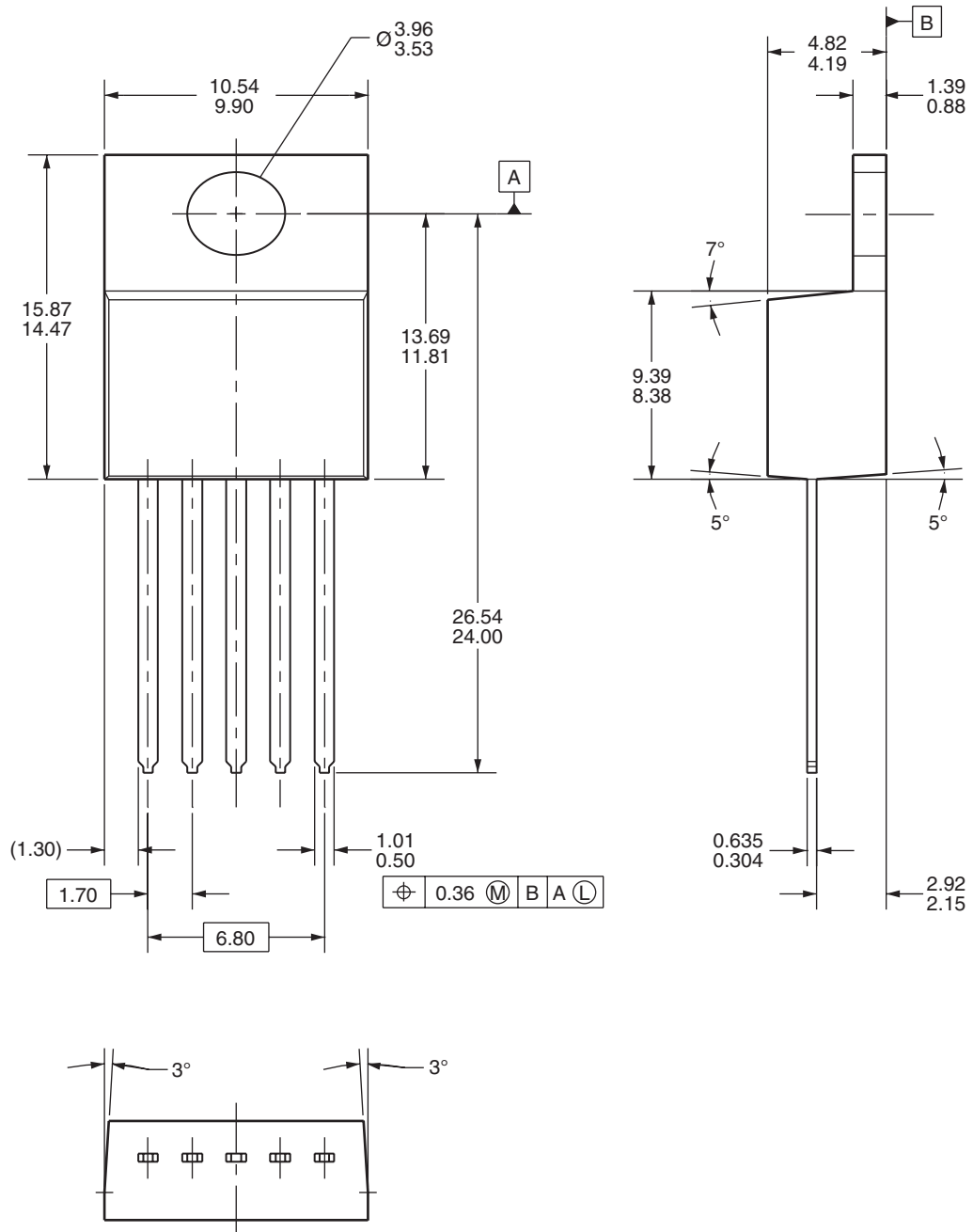







NOTES: UNLESS OTHERWISE SPECIFIED

- A) STANDARD LEAD FINISH: 200 MICRONS / 5.08 MICROMETERS MIN. LEAD/TIN 15/85 ON COPPER.
- B) REFERENCE JEDEC, TS-001, ISSUE A, VARIATION AA, DATED AUGUST 1989
- C) ALL DIMENSIONS ARE IN MILLIMETERS.
- D) DIMENSIONING AND TOLERANCING PER ASME Y14.5M-1994.



TRADEMARKS

The following includes registered and unregistered trademarks and service marks, owned by Fairchild Semiconductor and/or its global subsidiaries, and is not intended to be an exhaustive list of all such trademarks.

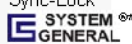
- | | | | |
|---|---|---|---|
| AccuPower™ | FPS™ | PowerTrench® | The Power Franchise® |
| Auto-SPM™ | F-PFST™ | PowerXS™ |  |
| Build it Now™ | FRFET® | Programmable Active Droop™ | TinyBoost™ |
| CorePLUS™ | Global Power Resource™ | QFET® | TinyBuck™ |
| CorePOWER™ | Green FPS™ | QST™ | TinyCalc™ |
| CROSSVOLT™ | Green FPS™ e-Series™ | Quiet Series™ | TinyLogic® |
| CTL™ | Gmax™ | RapidConfigure™ | TINYOPTO™ |
| Current Transfer Logic™ | GTO™ |  | TinyPower™ |
| EcoSPARK® | IntelliMAX™ | Saving our world, 1mW/W/kW at a time™ | TinyPVM™ |
| EfficientMax™ | ISOPLANAR™ | SmartMax™ | TinyWire™ |
| EZSWITCH™ | MegaBuck™ | SMART START™ | TriFault Detect™ |
|  | MICROCOUPLER™ | SPM® | TRUECURRENT™ |
|  | MicroFET™ | STEALTH™ | µSerDes™ |
| Fairchild® | MicroPak™ | SuperFET™ |  |
| Fairchild Semiconductor® | MillerDrive™ | SuperSOT™.3 | UHC® |
| FACT Quiet Series™ | MotionMax™ | SuperSOT™.6 | Ultra FRFET™ |
| FACT® | Motion-SPM™ | SuperSOT™.8 | UniFET™ |
| FAST® | OPTOLOGIC® | SupreMOS™ | VCX™ |
| FastvCore™ | OPTOPLANAR® | SyncFET™ | VisualMax™ |
| FETBench™ |  | Sync-Lock™ | XST™ |
| FlashWriter® | PDP SPM™ |  | |
| | Power-SPM™ | | |

* Trademarks of System General Corporation, used under license by Fairchild Semiconductor.

DISCLAIMER

FAIRCHILD SEMICONDUCTOR RESERVES THE RIGHT TO MAKE CHANGES WITHOUT FURTHER NOTICE TO ANY PRODUCTS HEREIN TO IMPROVE RELIABILITY, FUNCTION, OR DESIGN. FAIRCHILD DOES NOT ASSUME ANY LIABILITY ARISING OUT OF THE APPLICATION OR USE OF ANY PRODUCT OR CIRCUIT DESCRIBED HEREIN; NEITHER DOES IT CONVEY ANY LICENSE UNDER ITS PATENT RIGHTS, NOR THE RIGHTS OF OTHERS. THESE SPECIFICATIONS DO NOT EXPAND THE TERMS OF FAIRCHILD'S WORLDWIDE TERMS AND CONDITIONS, SPECIFICALLY THE WARRANTY THEREIN, WHICH COVERS THESE PRODUCTS.

LIFE SUPPORT POLICY

FAIRCHILD'S PRODUCTS ARE NOT AUTHORIZED FOR USE AS CRITICAL COMPONENTS IN LIFE SUPPORT DEVICES OR SYSTEMS WITHOUT THE EXPRESS WRITTEN APPROVAL OF FAIRCHILD SEMICONDUCTOR CORPORATION.

As used herein:

1. Life support devices or systems are devices or systems which, (a) are intended for surgical implant into the body or (b) support or sustain life, and (c) whose failure to perform when properly used in accordance with instructions for use provided in the labeling, can be reasonably expected to result in a significant injury of the user.
2. A critical component in any component of a life support, device, or system whose failure to perform can be reasonably expected to cause the failure of the life support device or system, or to affect its safety or effectiveness.

ANTI-COUNTERFEITING POLICY

Fairchild Semiconductor Corporation's Anti-Counterfeiting Policy. Fairchild's Anti-Counterfeiting Policy is also stated on our external website, www.fairchildsemi.com, under Sales Support.

Counterfeiting of semiconductor parts is a growing problem in the industry. All manufacturers of semiconductor products are experiencing counterfeiting of their parts. Customers who inadvertently purchase counterfeit parts experience many problems such as loss of brand reputation, substandard performance, failed applications, and increased cost of production and manufacturing delays. Fairchild is taking strong measures to protect ourselves and our customers from the proliferation of counterfeit parts. Fairchild strongly encourages customers to purchase Fairchild parts either directly from Fairchild or from Authorized Fairchild Distributors who are listed by country on our web page cited above. Products customers buy either from Fairchild directly or from Authorized Fairchild Distributors are genuine parts, have full traceability, meet Fairchild's quality standards for handling and storage and provide access to Fairchild's full range of up-to-date technical and product information. Fairchild and our Authorized Distributors will stand behind all warranties and will appropriately address any warranty issues that may arise. Fairchild will not provide any warranty coverage or other assistance for parts bought from Unauthorized Sources. Fairchild is committed to combat this global problem and encourage our customers to do their part in stopping this practice by buying direct or from authorized distributors.

PRODUCT STATUS DEFINITIONS

Definition of Terms

Datasheet Identification	Product Status	Definition
Advance Information	Formative / In Design	Datasheet contains the design specifications for product development. Specifications may change in any manner without notice.
Preliminary	First Production	Datasheet contains preliminary data; supplementary data will be published at a later date. Fairchild Semiconductor reserves the right to make changes at any time without notice to improve design.
No Identification Needed	Full Production	Datasheet contains final specifications. Fairchild Semiconductor reserves the right to make changes at any time without notice to improve the design.
Obsolete	Not In Production	Datasheet contains specifications on a product that is discontinued by Fairchild Semiconductor. The datasheet is for reference information only.

Rev. 141

Looking for pricing, stock, or lifecycle information?

Click below to explore more details on WIN SOURCE:

- ⊖ [View FAN1581T15 on WIN SOURCE](#)
- ⊖ [Fairchild/ON Semiconductor Information](#)

Optimize Your Supply Chain with WIN SOURCE Solutions

- ✓ Global Sourcing Solution
- ✓ Obsolete Management
- ✓ Cost Control Management
- ✓ Shortage Management
- ✓ Alternative Solution
- ✓ Excess Inventory Management