

# FAN2013 — 2A Low-Voltage, Current-Mode Synchronous PWM Buck Regulator

## Features

- 95% Efficiency, Synchronous Operation
- Adjustable Output Voltage from 0.8V to  $V_{IN}-1$
- 4.5V to 5.5V Input Voltage Range
- Up to 2A Output Current
- Fixed-Frequency 1.3 MHz PWM Operation
- 100% Duty Cycle Low-Dropout Operation (LDO)
- Soft-Start Function
- Excellent Load Transient Response
- Power-Good Flag
- Over-Voltage, Under-Voltage Lockout, Short-Circuit, and Thermal Shutdown Protections
- 3x3mm 6-lead MLP Package

## Applications

- Hard Disk Drive
- Set-Top Box
- Point-of-Load Power
- Notebook Computer
- Communications Equipment

## Description

The FAN2013 is a high-efficiency, low-noise, synchronous Pulse Width Modulated (PWM) current-mode DC-DC converter designed for low-voltage applications. It provides up to 2A continuous-load current from the 4.5V to 5.5V input. The output voltage is adjustable over a wide range by means of an external voltage divider.

The FAN2013 is enabled when the input voltage on the  $V_{IN}$  pin exceed the UVLO threshold.

A current-mode control loop with a fast transient response ensures excellent line and load regulation. The fixed 1.3MHz switching frequency enables designers to choose a small, inexpensive external inductor and capacitor. Filtering can be accomplished with small components, reducing space and cost.

Protection features include input under-voltage lockout, short-circuit protection, and thermal shutdown. Soft-start limits inrush current during start-up conditions.

The device is available in a 3x3mm 6-lead MLP.

## Typical Application

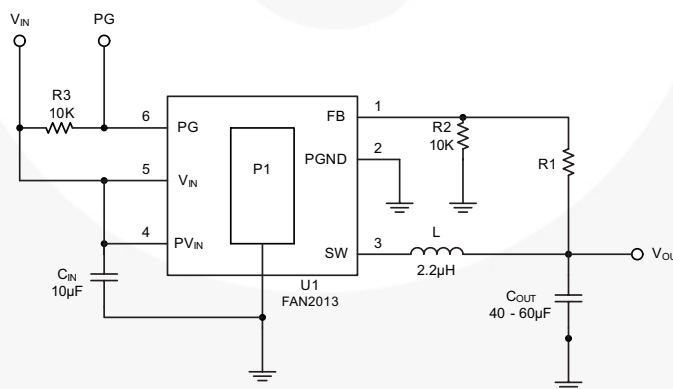

Figure 1. Typical Application

## Ordering Information

Part Number	Output Voltage	Package	Packing Method
FAN2013MPX	0.8V to $V_{IN}-1V$	3x3mm 6-Lead Molded Leadless Package (MLP)	Tape and Reel

All packages are lead free per JEDEC: J-STD-020B standard.

## Pin Assignments

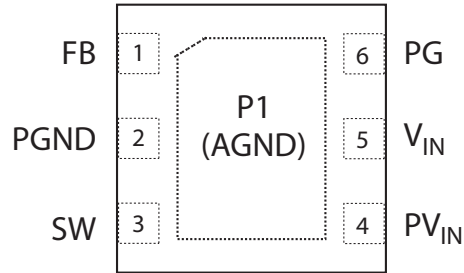

Figure 2. Pin Assignments (Top View)

## Pin Definitions

Pin #	Name	Description
P1	AGND	<b>Analog Ground.</b> P1 must be soldered to the PCB ground.
1	FB	<b>Feedback Input.</b> Adjustable voltage option; connect this pin to the resistor divider.
2	PGND	<b>Power Ground.</b> This pin is connected to the internal MOSFET switches. This pin must be externally connected to AGND.
3	SW	<b>Switching Node.</b> This pin is connected to the internal MOSFET switches.
4	PVIN	<b>Supply Voltage Input.</b> This pin is connected to the internal MOSFET switches.
5	VIN	<b>Supply Voltage Input.</b>
6	PG	<b>Open Drain Power Good.</b>

## Absolute Maximum Ratings

Stresses exceeding the absolute maximum ratings may damage the device. The device may not function or be operable above the recommended operating conditions and stressing the parts to these levels is not recommended. In addition, extended exposure to stresses above the recommended operating conditions may affect device reliability. The absolute maximum ratings are stress ratings only.

Symbol	Parameter	Min.	Max.	Unit
$V_{IN}$	Supply Voltage	-0.3	6.2	V
	Input Voltage on PVIN and Any Other Pin	-0.3	$V_{IN}$	V
$\theta_{JC}$	Thermal Resistance, Junction-to-Tab <sup>(1)</sup>		8	°C/W
$T_L$	Lead Soldering Temperature (10 Seconds)		260	°C
$T_{STG}$	Storage Temperature	-65	150	°C
$T_J$	Junction Temperature	-40	150	°C
ESD	Electrostatic Discharge Protection Level <sup>(2)</sup>	HBM	3.5	kV
		CDM	2	

### Notes:

- Junction-to-ambient thermal resistance,  $\theta_{JA}$ , is a strong function of PCB material, board thickness, thickness and number of copper planes, number of via used, diameter of via used, available copper surface, and attached heat sink characteristics.
- Using Mil Std. 883E, method 3015.7 (Human Body Model) and EIA/JESD22C101-A (Charged Device Model).

## Recommended Operating Conditions

The Recommended Operating Conditions table defines the conditions for actual device operation. Recommended operating conditions are specified to ensure optimal performance to the datasheet specifications. Fairchild does not recommend exceeding them or designing to Absolute Maximum Ratings.

Symbols	Parameter	Min.	Typ.	Max.	Unit
$V_{IN}$	Supply Voltage Range	4.5		5.5	V
$V_{OUT}$	Output Voltage Range, Adjustable Version	0.8		$V_{IN}-1$	V
$I_{OUT}$	Output Current			2.0	A
L	Inductor <sup>(3)</sup>		2.2		μH
$C_{IN}$	Input Capacitor <sup>(3)</sup>	10	20		μF
$C_{OUT}$	Output Capacitor <sup>(3)</sup>	20	40		μF
$T_A$	Operating Ambient Temperature Range	-40		+85	°C

### Note:

- Refer to the *Applications* section for details.

## Electrical Characteristics

$V_{IN} = 4.5V$  to  $5.5V$ ,  $V_{OUT} = 1.2V$ ,  $I_{OUT} = 200mA$ ,  $C_{IN} = 10\mu F$ ,  $C_{OUT} = 40\mu F$ ,  $L = 2.2\mu H$ ,  $T_A = -40^\circ C$  to  $+85^\circ C$ , unless otherwise noted. Typical values are at  $T_A = 25^\circ C$ .

Symbol	Parameter	Conditions	Min.	Typ.	Max.	Units
$V_{IN}$	Input Voltage		4.5		5.5	V
$I_Q$	Quiescent Current	$I_{OUT} = 0mA$		10	16	mA
$V_{UVLO}$	UVLO Threshold	$V_{IN}$ Rising	3.4	3.7	4.0	V
		Hysteresis		150		mV
$R_{ON\_PMOS}$	PMOS On Resistance	$V_{IN} = V_{GS} = 5V$		90		$M\Omega$
$R_{ON\_NMOS}$	NMOS On Resistance	$V_{IN} = V_{GS} = 5V$		90		$m\Omega$
$I_{LIMIT}$	P-Channel Current Limit	$4.5V < V_{IN} < 5.5V$	2.8	3.5	4.2	A
$T_{OVP}$	Over-Temperature Protection	Rising Temperature		150		$^\circ C$
		Hysteresis		20		$^\circ C$
$f_{SW}$	Switching Frequency		1000	1300	1600	kHz
$R_{LINE}$	Line Regulation	$V_{IN} = 4.5$ to $5.5V$ , $I_{OUT} = 100mA$		0.16		%/V
$R_{LOAD}$	Load Regulation	$0mA \leq I_{OUT} \leq 2000mA$		0.2	0.6	%
$V_{OUT}$	Output Voltage During Load Transition <sup>(4)</sup>	$I_{OUT}$ from 1500mA to 100mA, $C_{OUT} = 60\mu F$			5	%
		$I_{OUT}$ from 100mA to 1500mA, $C_{OUT} = 60\mu F$	-5			%
$I_{LEAK}$	Reverse Leakage Current into Pin SW	$V_{IN} = \text{Open}$ , $EN = GND$ , $V_{SW} = 5.5V$		0.1	1.0	$\mu A$
$V_{REF}$	Reference Voltage			0.8		V
$V_{OUT}$	Output Voltage Accuracy	$V_{IN} = 4.5$ to $5.5V$ , $0mA \leq I_{OUT} \leq 2000mA$ , $T_A = 0^\circ C$ to $+85^\circ C$	-2		2	%
		$V_{IN} = 4.5$ to $5.5V$ , $0mA \leq I_{OUT} \leq 2000mA$ , $T_A = -40^\circ C$ to $+85^\circ C$	-3		3	%
$V_{PG}$	Power Good Output Threshold and Hysteresis	FB Voltage Rising		$0.85 \times V_{OUT}$		%
		Hysteresis		2		V
$t_{PG}$	Power Good Output Delay			100		$\mu s$
$V_{PG\_LOW}$	Power Good Voltage Low	$I_{sink} = 6mA$ , Open-Drain Output			0.4	V
$V_{OVP}$	Over-Voltage Protection Threshold and Hysteresis	FB Voltage Rising		$1.07 \times V_{OUT}$		V
		Hysteresis		2		%

### Notes:

4. Please refer to the load transient response test waveform shown in Figure 3.

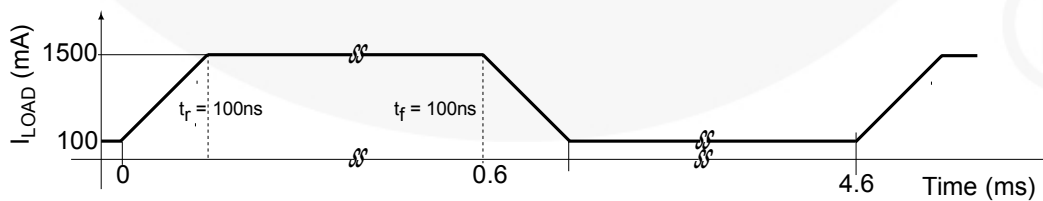

Figure 3. Load Transient Response Test Waveform

## Typical Performance Characteristics

$T_A = 25^\circ\text{C}$ ,  $C_{IN} = 10\mu\text{F}$ ,  $C_{OUT} = 40\mu\text{F}$ ,  $L = 2.2\mu\text{H}$ ,  $V_{IN} = 5\text{V}$ ,  $V_{OUT} = 1.2\text{V}$ , unless otherwise noted.

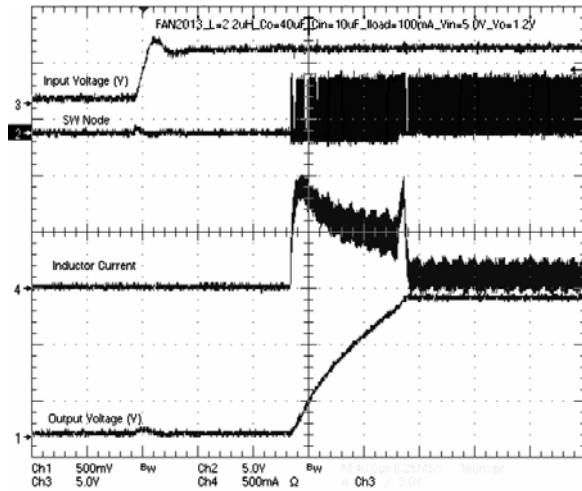

Figure 4. Start-up with 100mA Resistive Load

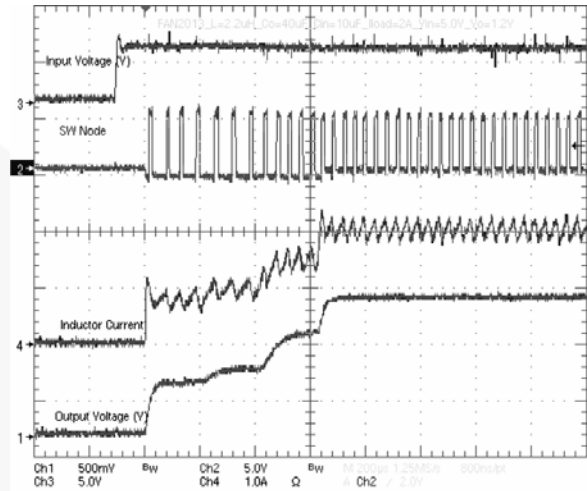

Figure 5. Start-up with 2A Resistive Load

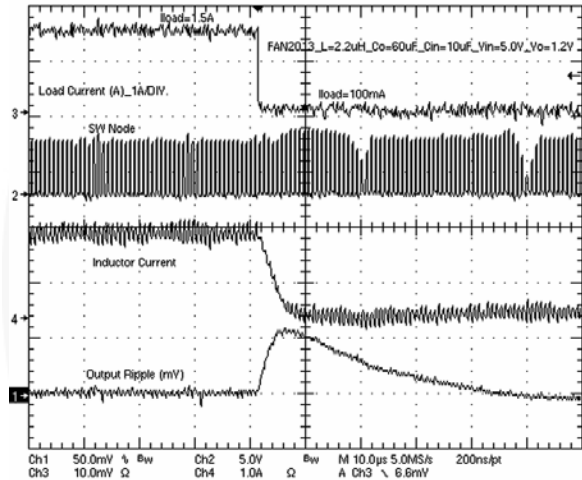

Figure 6. Load Transient Response 1.5A to 100mA

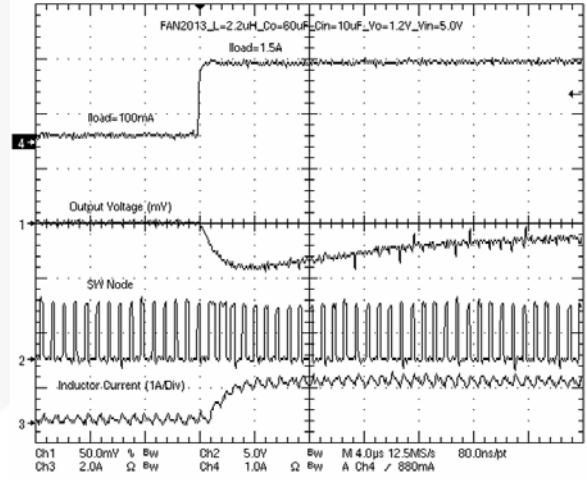

Figure 7. Load Transient Response 100mA to 1.5A

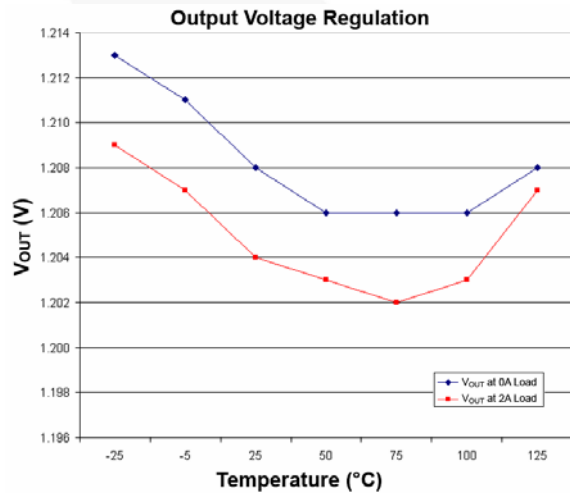

Figure 8. Output Voltage Regulation

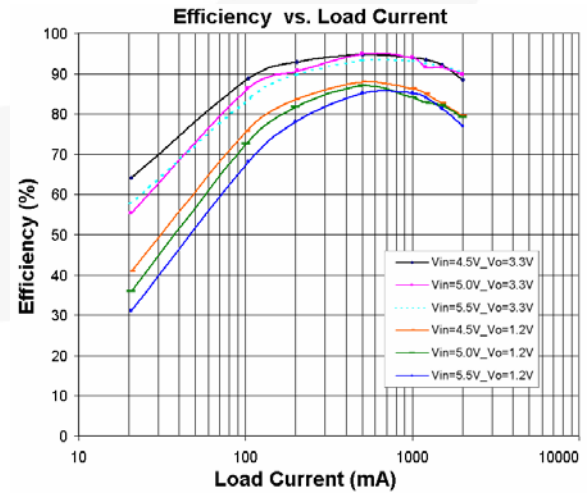

Figure 9. Power Efficiency

## Block Diagram

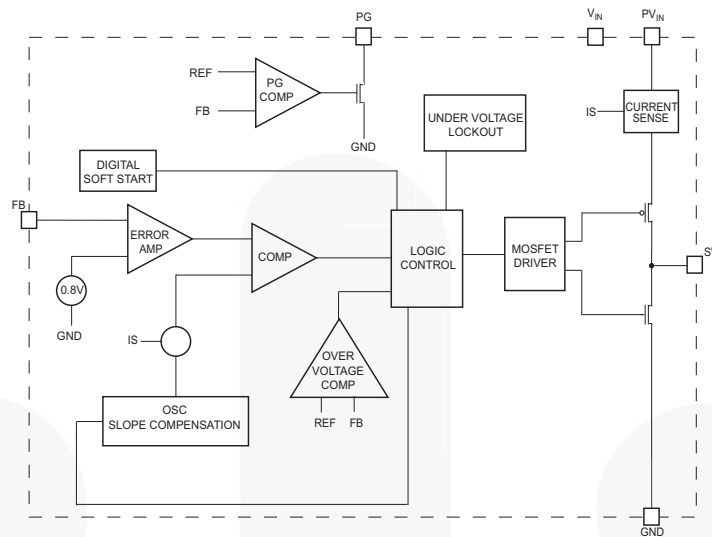

Figure 10. Block Diagram

## Detailed Operation Description

The FAN2013 is a step-down pulse-width modulated (PWM) current mode converter with a fixed switching frequency of 1.3MHz. At the rising edge of each clock cycle, the P-channel transistor is turned on until the PWM comparator trips or the current limit is reached. During the ON time, the inductor current ramps up and is monitored by the internal current-mode control loop. After a minimum dead time, the N-channel transistor is turned ON and the inductor current ramps down. As the clock cycle is completed, the N-channel switch is turned OFF and the next clock cycle starts. The duty cycle is given by the ratio of output voltage and input voltage. The converter runs at minimum duty cycle when output voltage is at minimum and input voltage is at maximum, and at 100% duty cycle when the input voltage approaches the output voltage, as described below.

### 100% Duty Cycle Operation

As the input voltage approaches the output voltage and the duty cycle exceeds the typical 95%, the converter turns the P-channel transistor continuously on. In this mode, the output voltage is equal to the input voltage, minus the voltage drop across the P-channel transistor:

$$V_{OUT} = V_{IN} - I_{LOAD} \times (R_{DS\_ON} + R_L) \quad (1)$$

where

$R_{DS\_ON}$  = P-channel switch on resistance

$I_{LOAD}$  = Output current

$R_L$  = Inductor DC resistance

### UVLO and Soft Start

The internal voltage reference,  $V_{REF}$ , and the IC remain reset until  $V_{IN}$  reaches the 3.7V UVLO threshold.

The FAN2013 has an internal soft-start circuit that limits the inrush current during start-up. This prevents possible voltage drops of the input voltage and eliminates the output voltage overshoot. The soft-start is implemented as a digital circuit, increasing the switch current in four steps to the P-channel current limit (3.5A). Typical start-up time for a 40 $\mu$ F output capacitor with a load current of 2.0A is 800 $\mu$ s.

### Output Over-Voltage Protection

When output voltage,  $V_{OUT}$ , reaches approximately 7% above the nominal value, the device turns OFF the P-channel switch and turns ON part of the N-channel transistor with a built-in current limit of about 400mA. When  $V_{OUT}$  reaches the hysteresis of about 2%, the device starts switching normally in closed loop. If output voltage is pulled up by an external voltage source with a current limit higher than typical 400mA, the output voltage stays up at the external voltage source level.

The over-voltage protection is designed to limit the output voltage excursion in case of a transient response from full load to a minimum load.

### Output Short-Circuit Protection

The switch peak current is limited cycle by cycle to a typical value of 3.5A. In the event of an output voltage short circuit, the device operates with a frequency of 400kHz and minimum duty cycle, making the average typical input current .45A.

### Thermal Shutdown

When the die temperature exceeds 150°C, a reset occurs and remains in effect until the die cools to 130°C, when the circuit is allowed to restart.

## Applications Information

### Setting the Output Voltage

The internal voltage reference is 0.8V. The output is divided down by a voltage divider, R1 and R2 to the FB pin. The output voltage is:

$$V_{OUT} = V_{REF} \left( 1 + \frac{R_1}{R_2} \right) \quad (2)$$

According to this equation, assuming desired output voltage of 1.2V, and given R2 = 10KΩ as the recommended resistance for any output voltage setting, the calculated value of R1 is 5KΩ.

### Inductor Selection

The inductor parameters directly related to device performance are saturation current and DC resistance. The FAN2013 operates with a typical inductor value of 2.2μH. The lower the DC resistance, the higher the efficiency. For saturation current, the inductor should be rated higher than the maximum load current, plus half of the inductor ripple current, calculated by:

$$\Delta I_L = V_{OUT} \times \frac{1 - (V_{OUT}/V_{IN})}{L \times f} \quad (3)$$

where:

ΔI<sub>L</sub> = Inductor Ripple Current  
 f = Switching Frequency  
 L = Inductor Value

Recommended inductors are listed in Table 1.

**Table 1. Recommended Inductors**

Inductor Value	Vendor	Part Number
2.2μH	Coiltronics	SD25 2R2
2.2μH	Murata	LQH66SSN2R2M03

### Capacitors Selection

For best performances, a low-ESR input capacitor is required. A ceramic capacitor of at least 10μF, placed as close to the V<sub>IN</sub> and AGND pins as possible is recommended.

The output capacitor determines the output ripple and the transient response. A minimum of 20μF output capacitor is required for the FAN2013 to operate in stable conditions.

**Table 2. Recommended Capacitors**

Capacitor Value	Vendor	Part Number
10μF	Taiyo Yuden	JMK212BJ106MG
		JMK316BJ106KL
	TDK	C2012X5ROJ106K
		C3216X5ROJ106M
Murata	GRM32ER61C106K	

### PCB Layout Recommendations

The inherently high peak currents and switching frequency of power supplies require a careful PCB layout design. For best results, use wide traces for high-current paths and place the input capacitor, the inductor, and the output capacitor as close as possible to the integrated circuit terminals. To minimize voltage stress to the device resulting from ever-present switching spikes, use an input bypass capacitor with low ESR. Note that the peak amplitude of the switching spikes depends upon the load current; the higher the load current, the higher the switching spikes.

The resistor divider that sets the output voltage should be routed away from the inductor to avoid RF coupling. The ground plane at the bottom side of the PCB acts as an electromagnetic shield to reduce EMI. The recommended PCB layout is shown below in Figure 11.

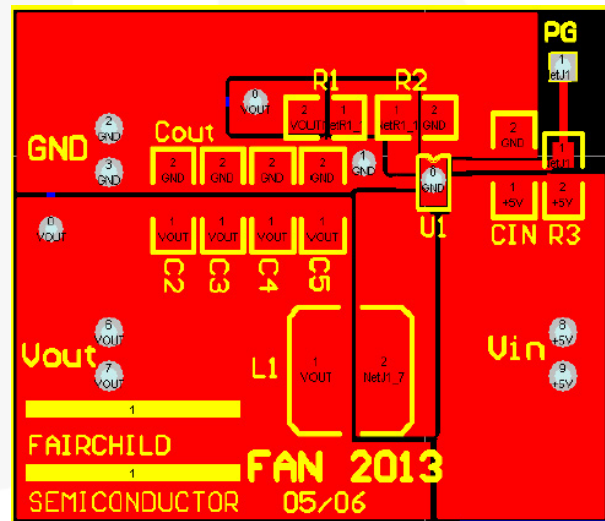

**Figure 11. Recommended PCB Layout**

## Physical Dimensions

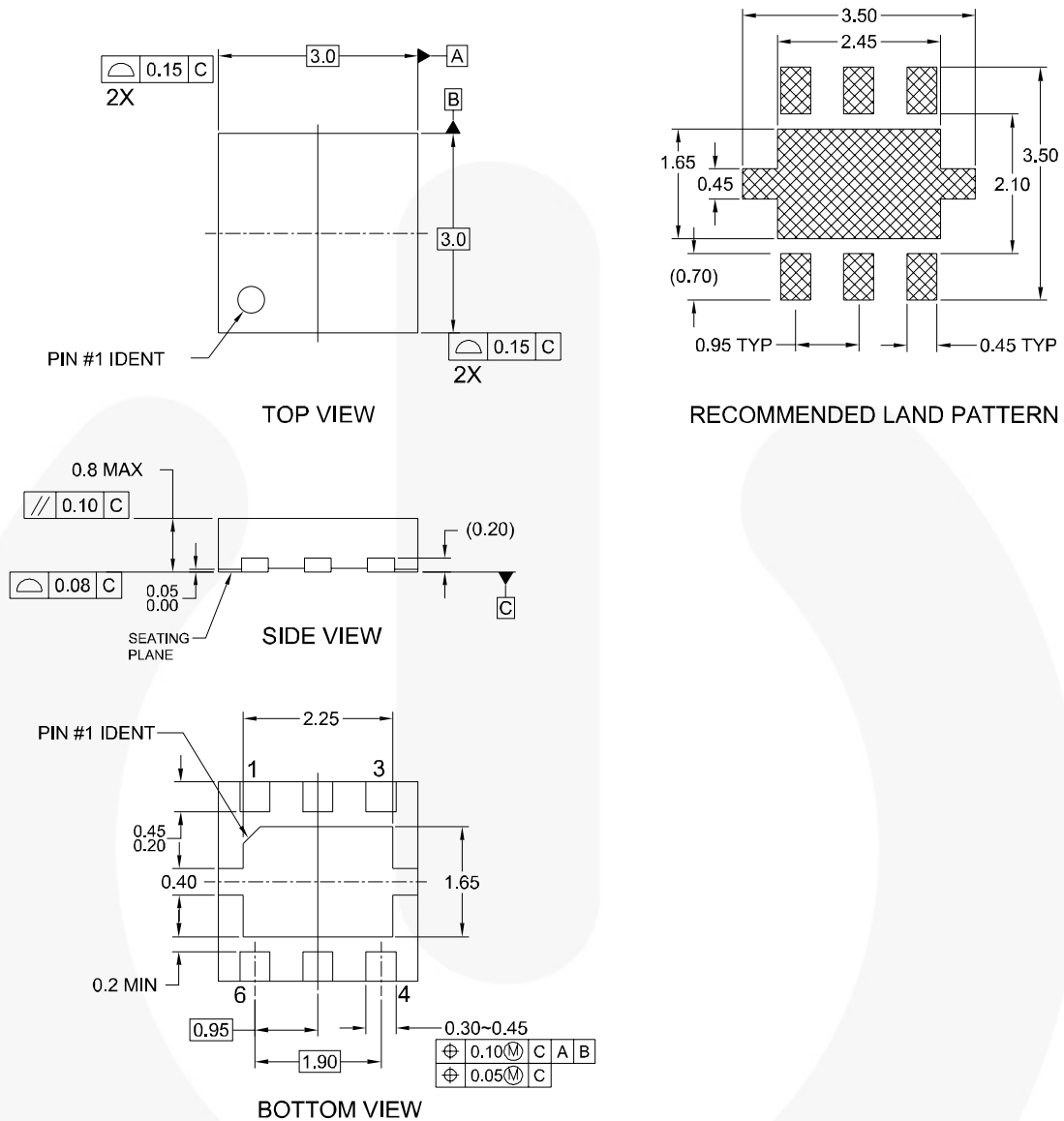

### NOTES:

- A. CONFORMS TO JEDEC REGISTRATION MO-229, VARIATION WEEA, DATED 11/2001 EXCEPT FOR DAP EXTENSION TABS
- B. DIMENSIONS ARE IN MILLIMETERS.
- C. DIMENSIONS AND TOLERANCES PER ASME Y14.5M, 1994

MLP06FrevA

**Figure 12. 3x3mm 6-Lead Molded Leadless Package (MLP)**

Package drawings are provided as a service to customers considering Fairchild components. Drawings may change in any manner without notice. Please note the revision and/or date on the drawing and contact a Fairchild Semiconductor representative to verify or obtain the most recent revision. Package specifications do not expand the terms of Fairchild's worldwide terms and conditions, specifically the warranty therein, which covers Fairchild products.

Always visit Fairchild Semiconductor's online packaging area for the most recent package drawings:  
<http://www.fairchildsemi.com/packaging/>



### TRADEMARKS

The following includes registered and unregistered trademarks and service marks, owned by Fairchild Semiconductor and/or its global subsidiaries, and is not intended to be an exhaustive list of all such trademarks.

ACEX <sup>®</sup>	FPS <sup>™</sup>	PDP-SPM <sup>™</sup>	SupreMOS <sup>™</sup>
Build it Now <sup>™</sup>	FRFET <sup>®</sup>	Power220 <sup>®</sup>	SyncFET <sup>™</sup>
CorePLUS <sup>™</sup>	Global Power Resource <sup>SM</sup>	POWEREDGE <sup>®</sup>	 SYSTEM GENERAL <sup>®</sup>
CROSSVOLT <sup>™</sup>	Green FPS <sup>™</sup>	Power-SPM <sup>™</sup>	The Power Franchise <sup>®</sup>
CTL <sup>™</sup>	Green FPS <sup>™</sup> e-Series <sup>™</sup>	PowerTrench <sup>®</sup>	 the power franchise <sup>®</sup>
Current Transfer Logic <sup>™</sup>	GTO <sup>™</sup>	Programmable Active Droop <sup>™</sup>	TinyBoost <sup>™</sup>
EcoSPARK <sup>®</sup>	<i>i-Lo</i> <sup>™</sup>	QFET <sup>®</sup>	TinyBuck <sup>™</sup>
EZSWITCH <sup>™</sup> *	IntelliMAX <sup>™</sup>	QS <sup>™</sup>	TinyLogic <sup>®</sup>
 EZ <sup>™</sup>	ISOPLANAR <sup>™</sup>	QT Optoelectronics <sup>™</sup>	TINYOPTO <sup>™</sup>
 F <sup>®</sup>	MegaBuck <sup>™</sup>	Quiet Series <sup>™</sup>	TinyPower <sup>™</sup>
Fairchild <sup>®</sup>	MICROCOUPLER <sup>™</sup>	RapidConfigure <sup>™</sup>	TinyPWM <sup>™</sup>
Fairchild Semiconductor <sup>®</sup>	MicroFET <sup>™</sup>	SMART START <sup>™</sup>	TinyWire <sup>™</sup>
FACT Quiet Series <sup>™</sup>	MicroPak <sup>™</sup>	SPM <sup>®</sup>	μSerDes <sup>™</sup>
FACT <sup>®</sup>	MillerDrive <sup>™</sup>	STEALTH <sup>™</sup>	UHC <sup>®</sup>
FAST <sup>®</sup>	Motion-SPM <sup>™</sup>	SuperFET <sup>™</sup>	Ultra FRFET <sup>™</sup>
FastvCore <sup>™</sup>	OPTOLOGIC <sup>®</sup>	SuperSOT <sup>™</sup> .3	UniFET <sup>™</sup>
FlashWriter <sup>®</sup> +	OPTOPLANAR <sup>®</sup>	SuperSOT <sup>™</sup> .6	Vcx <sup>™</sup>
		SuperSOT <sup>™</sup> .8	

\* EZSWITCH<sup>™</sup> and FlashWriter<sup>®</sup> are trademarks of System General Corporation, used under license by Fairchild Semiconductor.

### DISCLAIMER

FAIRCHILD SEMICONDUCTOR RESERVES THE RIGHT TO MAKE CHANGES WITHOUT FURTHER NOTICE TO ANY PRODUCTS HEREIN TO IMPROVE RELIABILITY, FUNCTION, OR DESIGN. FAIRCHILD DOES NOT ASSUME ANY LIABILITY ARISING OUT OF THE APPLICATION OR USE OF ANY PRODUCT OR CIRCUIT DESCRIBED HEREIN; NEITHER DOES IT CONVEY ANY LICENSE UNDER ITS PATENT RIGHTS, NOR THE RIGHTS OF OTHERS. THESE SPECIFICATIONS DO NOT EXPAND THE TERMS OF FAIRCHILD'S WORLDWIDE TERMS AND CONDITIONS, SPECIFICALLY THE WARRANTY THEREIN, WHICH COVERS THESE PRODUCTS.

### LIFE SUPPORT POLICY

FAIRCHILD'S PRODUCTS ARE NOT AUTHORIZED FOR USE AS CRITICAL COMPONENTS IN LIFE SUPPORT DEVICES OR SYSTEMS WITHOUT THE EXPRESS WRITTEN APPROVAL OF FAIRCHILD SEMICONDUCTOR CORPORATION.

As used herein:

1. Life support devices or systems are devices or systems which, (a) are intended for surgical implant into the body or (b) support or sustain life, and (c) whose failure to perform when properly used in accordance with instructions for use provided in the labeling, can be reasonably expected to result in a significant injury of the user.
2. A critical component in any component of a life support device, or system whose failure to perform can be reasonably expected to cause the failure of the life support device or system, or to affect its safety or effectiveness.

### PRODUCT STATUS DEFINITIONS

#### Definition of Terms

Datasheet Identification	Product Status	Definition
Advance Information	Formative or In Design	This datasheet contains the design specifications for product development. Specifications may change in any manner without notice.
Preliminary	First Production	This datasheet contains preliminary data; supplementary data will be published at a later date. Fairchild Semiconductor reserves the right to make changes at any time without notice to improve design.
No Identification Needed	Full Production	This datasheet contains final specifications. Fairchild Semiconductor reserves the right to make changes at any time without notice to improve the design.
Obsolete	Not In Production	This datasheet contains specifications on a product that has been discontinued by Fairchild Semiconductor. The datasheet is printed for reference information only.

Rev. 133

## Looking for pricing, stock, or lifecycle information?

Click below to explore more details on WIN SOURCE:

- ⊖ [View FAN2013MPX on WIN SOURCE](#)
- ⊖ [Fairchild/ON Semiconductor Information](#)

## Optimize Your Supply Chain with WIN SOURCE Solutions

- ✓ Global Sourcing Solution
- ✓ Obsolete Management
- ✓ Cost Control Management
- ✓ Shortage Management
- ✓ Alternative Solution
- ✓ Excess Inventory Management