



**THE DATASHEET OF
CGHV1F006S**



CGHV1F006S

6 W, DC - 15 GHz, 40 V, GaN HEMT

Description

The CGHV1F006S is an unmatched, gallium nitride (GaN) high electron mobility transistor (HEMT) designed specifically for high efficiency, high gain and wide bandwidth capabilities. The device can be deployed for L, S, C, X and Ku-Band amplifier applications. The datasheet specifications are based on a C-Band (5.5 - 6.5 GHz) amplifier. Additional application circuits are available for C-Band at 5.8 GHz - 7.2 GHz and X-Band at 7.9 - 8.4 GHz and 8.5 - 9.6 GHz. The CGHV1F006S operates on a 40 volt rail circuit while housed in a 3mm x 4mm, surface mount, dual-flat-no-lead (DFN) package. Under reduced power, the transistor can operate below 40V to as low as 20V V_{DD} , maintaining high gain and efficiency.

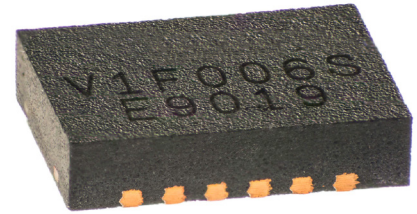

Package Type: 3x4 DFN
PN: CGHV1F006S

Features for 40 V in CGHV1F006S-AMP

- Up to 15 GHz Operation
- 8 W Typical Output Power
- 17 dB Gain at 6.0 GHz
- 15 dB Gain at 9.0 GHz
- Application circuits for 5.8 - 7.2 GHz, 7.9 - 8.4GHz, and 8.5 - 9.6 GHz.
- High degree of APD and DPD correction can be applied

Typical Performance Over 5.5 - 6.5 GHz ($T_c = 25^\circ\text{C}$), 40 V

Parameter	5.5 GHz	6.0 GHz	6.5 GHz	Units
Small Signal Gain	15.4	16.5	17.8	dB
Output Power @ $P_{IN} = 28$ dBm	38.6	39.3	39.0	dBm
Drain Efficiency @ $P_{IN} = 28$ dBm	55	57	52	%

Listing of Available Hardware Application Circuits / Demonstration Circuits

Application Circuit	Operating Frequency	Amplifier Class	Operating Voltage
CGHV1F006S-AMP1	5.85 - 7.2 GHz	Class A/B	40 V
CGHV1F006S-AMP2	7.9 - 8.4 GHz	Class A/B	40 V
CGHV1F006S-AMP3	8.5 - 9.6 GHz	Class A/B	40 V
CGHV1F006S-AMP4	4.9 - 5.9 GHz	Class A/B	20 V



Large Signal Models Available for ADS and MWO



Absolute Maximum Ratings (not simultaneous) at 25°C Case Temperature

Parameter	Symbol	Rating	Units	Notes
Drain-Source Voltage	V_{DSS}	120	V	25 °C
Gate-to-Source Voltage	V_{GS}	-10, +2		
Storage Temperature	T_{STG}	-65, +150	°C	
Operating Junction Temperature	T_J	225		
Maximum Forward Gate Current	I_{GMAX}	1.2	mA	25 °C
Maximum Drain Current ¹	I_{DMAX}	0.95	A	
Soldering Temperature ²	T_S	245	°C	
Case Operating Temperature ^{3,4}	T_C	-40, +150		
Thermal Resistance, Junction to Case ⁵	$R_{\theta JC}$	14.5	°C/W	85 °C

Notes:

¹ Current limit for long term, reliable operation

² Refer to the Application Note on soldering

³ Simulated at $P_{DISS} = 2.4$ W

⁴ T_C = Case temperature for the device. It refers to the temperature at the ground tab underneath the package. The PCB will add additional thermal resistance

⁵ The R_{TH} for the application circuit, CGHV1F006S-AMP, with 31 (Ø11 mil) via holes designed on a 20 mil thick Rogers 5880 PCB, is 3.9°C/W. The total R_{TH} from the heat sink to the junction is 14.5°C/W + 3.9°C/W = 18.4°C/W

Electrical Characteristics (TC = 25°C), 40 V Typical

Characteristics	Symbol	Min.	Typ.	Max.	Units	Conditions
DC Characteristics¹						
Gate Threshold Voltage	$V_{GS(th)}$	-3.6	-3.0	-2.4	V_{DC}	$V_{DS} = 10$ V, $I_D = 1.2$ mA
Gate Quiescent Voltage	$V_{GS(Q)}$	-	-2.7	-	V_{DC}	$V_{DS} = 40$ V, $I_D = 60$ mA
Saturated Drain Current ²	I_{DS}	0.86	1.2	-	A	$V_{DS} = 6.0$ V, $V_{GS} = 2.0$ V
Drain-Source Breakdown Voltage	$V_{(BR)DSS}$	100	-	-	V_{DC}	$V_{GS} = -8$ V, $I_D = 1.2$ mA
RF Characteristics³ ($T_C = 25^\circ\text{C}$, $F_0 = 5.925$ GHz unless otherwise noted)						
Small Signal Gain ^{3,4}	G	15.15	17.4	-	dB	$V_{DD} = 40$ V, $I_{DQ} = 60$ mA, $P_{IN} = 10$ dBm
Output Power ^{3,4}	P_{OUT}	37.5	38.7	-	dBm	$V_{DD} = 40$ V, $I_{DQ} = 60$ mA, $P_{IN} = 25.5$ dBm
Drain Efficiency ^{3,4}	η	35	52	-	%	
Output Mismatch Stress ⁴	VSWR	-	10 : 1	-	Ψ	No damage at all phase angles, $V_{DD} = 40$ V, $I_{DQ} = 60$ mA, $P_{IN} = 25.5$ dBm
Dynamic Characteristics						
Input Capacitance ⁵	C_{GS}	-	1.3	-	pF	$V_{DS} = 40$ V, $V_{GS} = -8$ V, $f = 1$ MHz
Output Capacitance ⁵	C_{DS}	-	0.31	-		
Feedback Capacitance	C_{GD}	-	0.04	-		

Notes:

¹ Measured on wafer prior to packaging

² Scaled from PCM data

³ Measured in production test fixture. This fixture is designed for high volume testing at 5.925 GHz

⁴ Unmodulated Pulsed Signal 100 μ s, 10% duty cycle

⁵ Includes package

Electrical Characteristics When Tested in CGHV1F006S-AMP1 at C-Band Under OQPSK

Characteristics	Symbol	Min.	Typ.	Max.	Units	Conditions
RF Characteristics¹ ($T_c = 25^\circ\text{C}$, $F_0 = 5.8 - 7.2$ GHz unless otherwise noted)						
Gain	G	-	17.5	-	dB	$V_{DD} = 40\text{ V}$, $I_{DQ} = 60\text{ mA}$, $P_{IN} = 0\text{ dBm}$
Output Power ²	P_{OUT}	-	39	-	dBm	$V_{DD} = 40\text{ V}$, $I_{DQ} = 60\text{ mA}$, $P_{IN} = 27\text{ dBm}$
Drain Efficiency ²	η	-	55	-	%	
OQPSK ³	ACLR	-	-36	-	dBc	$V_{DD} = 40\text{ V}$, $I_{DQ} = 60\text{ mA}$, $P_{OUT} = 33\text{ dBm}$
Output Mismatch Stress ²	VSWR	-	10:1	-	Ψ	No damage at all phase angles, $V_{DS} = 40\text{ V}$, $I_{DQ} = 60\text{ mA}$

Notes:

¹ Measured in CGH1F006S-AMP1 Application Circuit

² Pulsed 100 μs , 10% duty cycle

³ OQPSK modulated signal, 1.6 msp/s, PN23, Alpha Filter = 0.2 Offset = 1.6 MHz

Typical Performance - CGHV1F006S-AMP1 at C-Band Under OQPSK

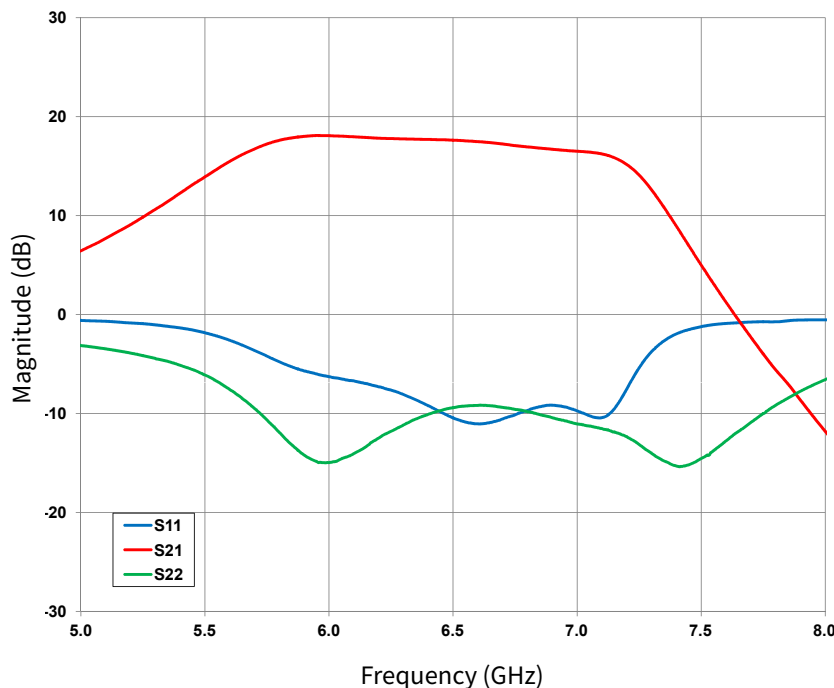

Figure 1. Typical Small Signal Response of CGHV1F006S-AMP1 Application Circuit

$$V_{DD} = 40\text{ V}, I_{DQ} = 60\text{ mA}$$

Typical Performance in Application Circuit CGHV1F006S-AMP1

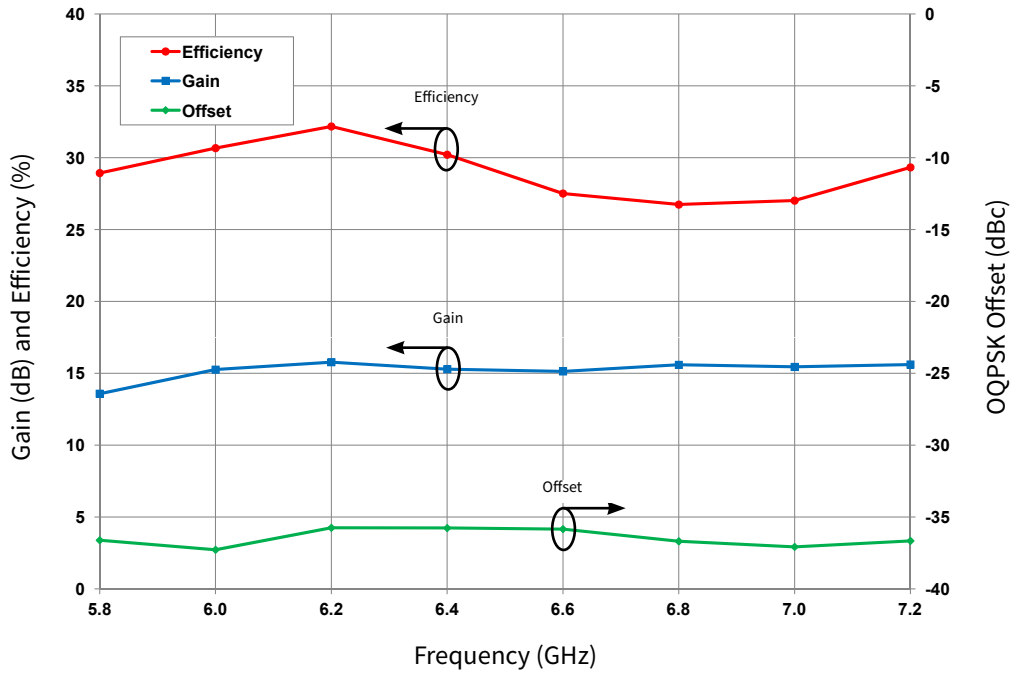

Figure 2. Typical Gain, Efficiency and OQPSK Performance vs Frequency
 $P_{OUT} = 33$ dBm, $V_{DD} = 40$ V, $I_{DQ} = 60$ mA

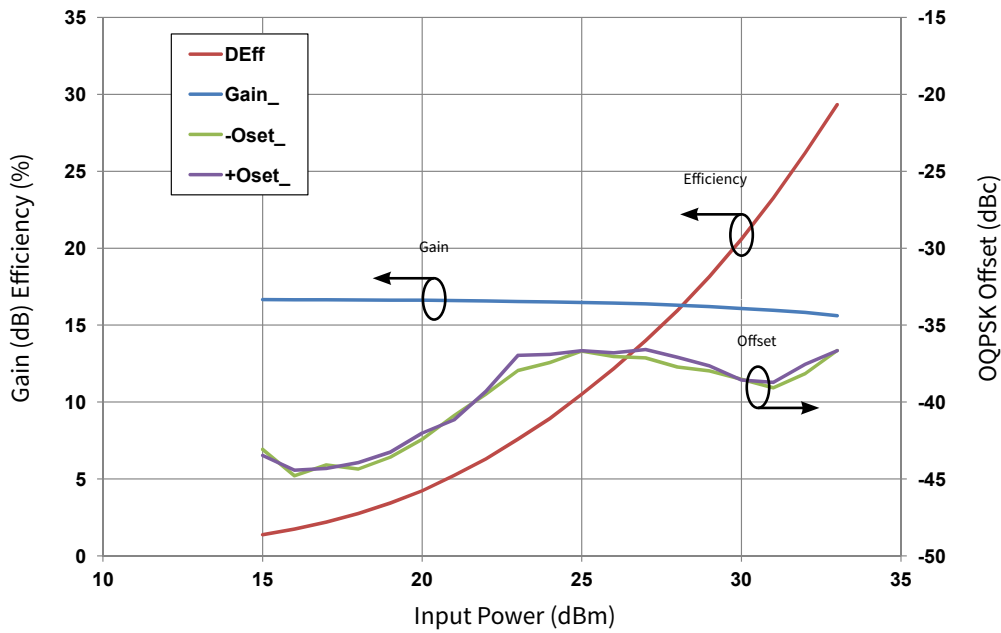

Figure 3. Typical Gain, Efficiency and OQPSK Performance vs Input Power OQPSK Transfer
 Frequency = 7.2 GHz, $V_{DD} = 40$ V, $I_{DQ} = 60$ mA

Typical Performance in Application Circuit CGHV1F006S-AMP1

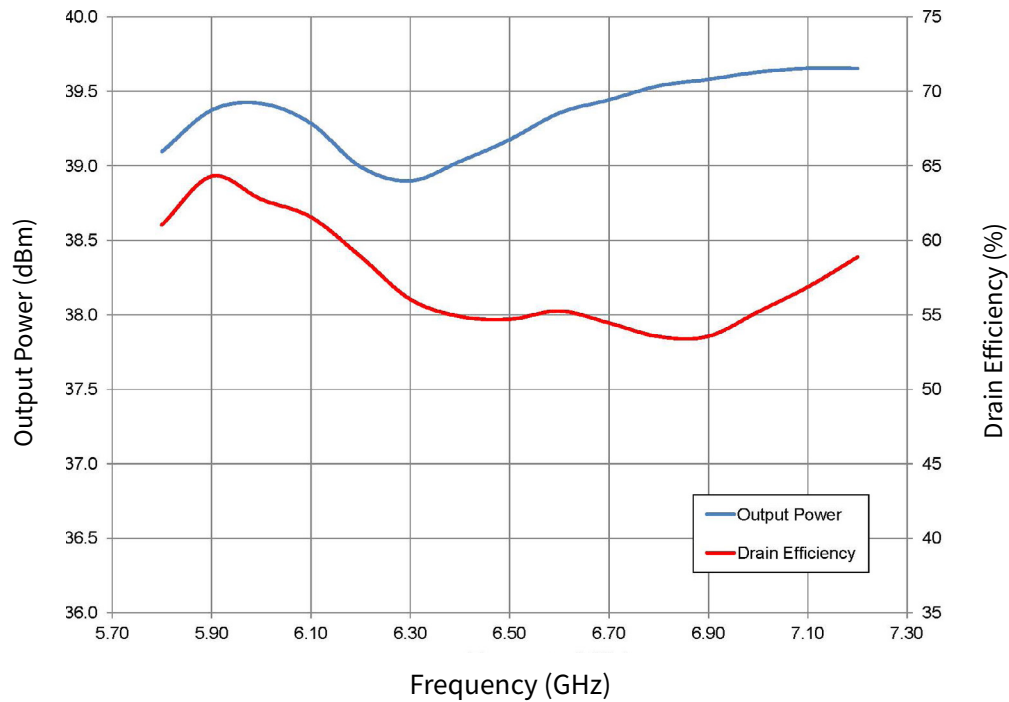
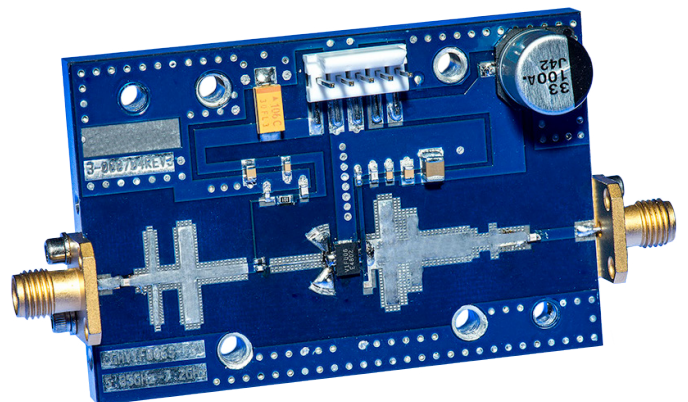

Figure 4. Typical Pulsed Power Response
 $V_{DD} = 40\text{ V}$, $I_{DQ} = 60\text{ mA}$, $100\ \mu\text{s}$, 10% Duty, $P_{IN} = 27\text{ dBm}$

CGHV1F006S-AMP1 Application Circuit Bill of Materials, OQPSK

Designator	Description	Qty
R1	RES, 15 ohm, +/-1%, 1/16 W, 0402	1
R2	RES, 100 ohm, +/-1%, 1/16 W, 0603	1
C1, C14	CAP, 1.8 pF, ±0.1 pF, 0603, ATC	2
C2	CAP, 2.0 pF, ±0.1 pF, 0402, ATC	1
C3, C8	CAP, 1.5 pF, ±0.1 pF, 0402, ATC	2
C4	CAP, 10 pF, ±5%, 0603, ATC	1
C5, C10	CAP, 470 pF, 5%, 100 V, 0603, X	2
C6, C11	CAP, 33000 pF, 0805, 100V, X7R	2
C7	CAP, 10 μF, 16 V, TANTALUM	1
C9	CAP, 20 pF, ±5%, 0603, ATC	1
C12	CAP, 1.0 μF, 100V, 10% X7R, 1210	1
C13	CAP, 33 μF, 20%, G CASE	1
J1, J2	CONN, SMA, PANEL MOUNT JACK, FLANGE	2
	PCB, RT5880, 0.020" THK, CGHV1F006S	1
J3	HEADER RT>PLZ .1CEN LK 5POS	1
Q1	QFN TRANSISTOR CGHV1F006S	1

CGHV1F006S-AMP1 Application Circuit



CGHV1F006S-AMP1 Application Circuit Schematic, OQPSK

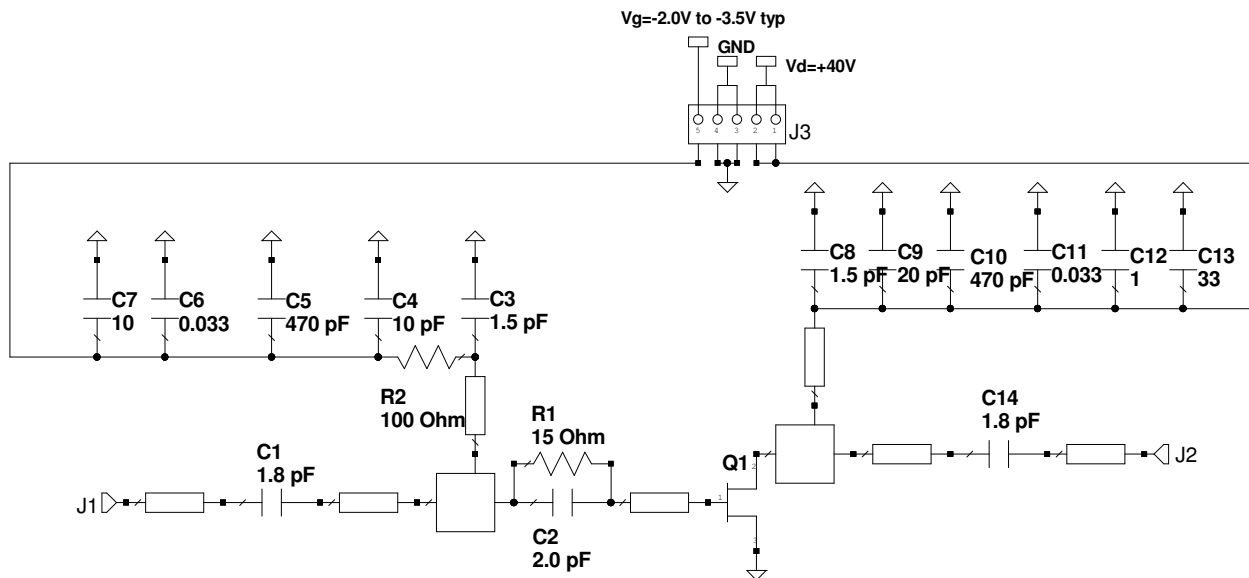

CGHV1F006S-AMP1 Application Circuit Outline, OQPSK

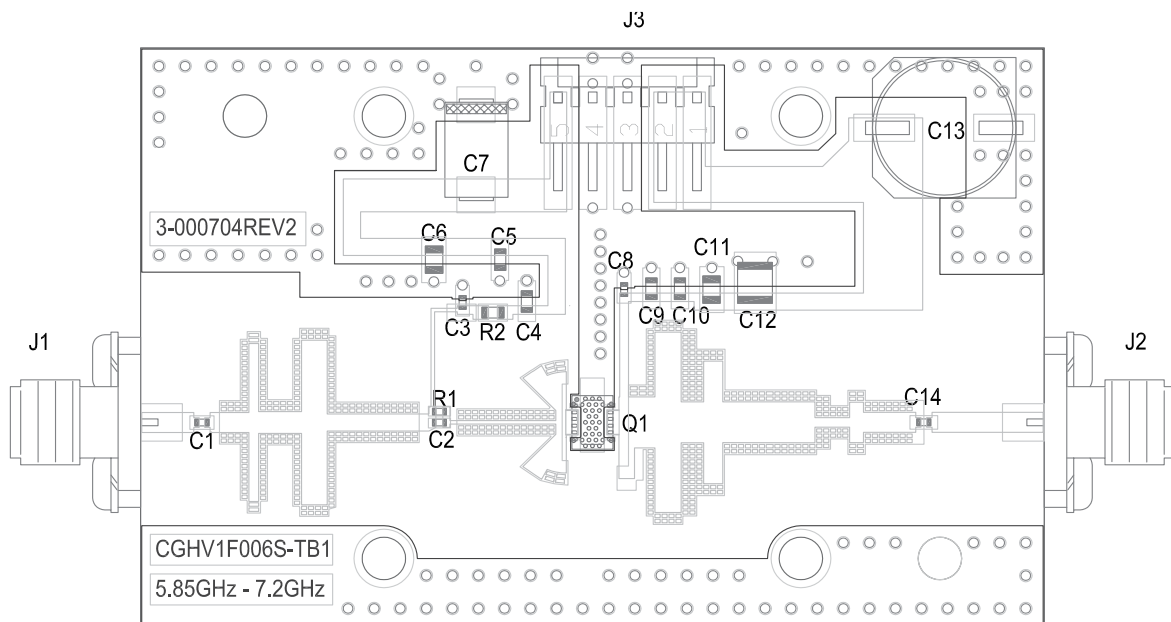

Electrical Characteristics When Tested in CGHV1F006S-AMP2 at X-Band, SATCOM

Characteristics	Symbol	Min.	Typ.	Max.	Units	Conditions
RF Characteristics ¹ ($T_c = 25^\circ\text{C}$, $F_0 = 7.9 - 8.4$ GHz unless otherwise noted)						
Gain	G	-	15	-	dB	$V_{DD} = 40\text{ V}$, $I_{DQ} = 60\text{ mA}$, $P_{IN} = 0\text{ dBm}$
Output Power ²	P_{OUT}	-	39	-	dBm	$V_{DD} = 40\text{ V}$, $I_{DQ} = 60\text{ mA}$, $P_{IN} = 28\text{ dBm}$
Drain Efficiency ²	η	-	55	-	%	
OQPSK ³	ACLR	-	-37		dBc	$V_{DD} = 40\text{ V}$, $I_{DQ} = 60\text{ mA}$, $P_{OUT} = 33\text{ dBm}$
Output Mismatch Stress ²	VSWR	-	10 : 1	-	Ψ	No damage at all phase angles, $V_{DD} = 40\text{ V}$, $I_{DQ} = 60\text{ mA}$, $P_{IN} = 28\text{ dBm}$

Notes:

¹ Measured in CGHV1F006S-AMP2 Application Circuit² Pulsed 100 μs , 10% duty cycle³ OQPSK modulated signal, 1.6 msp/s, PN23, Alpha Filter = 0.2 Offset = 1.6 MHz

Typical Performance in Application Circuit CGHV1F006S-AMP2 at X-Band, SATCOM

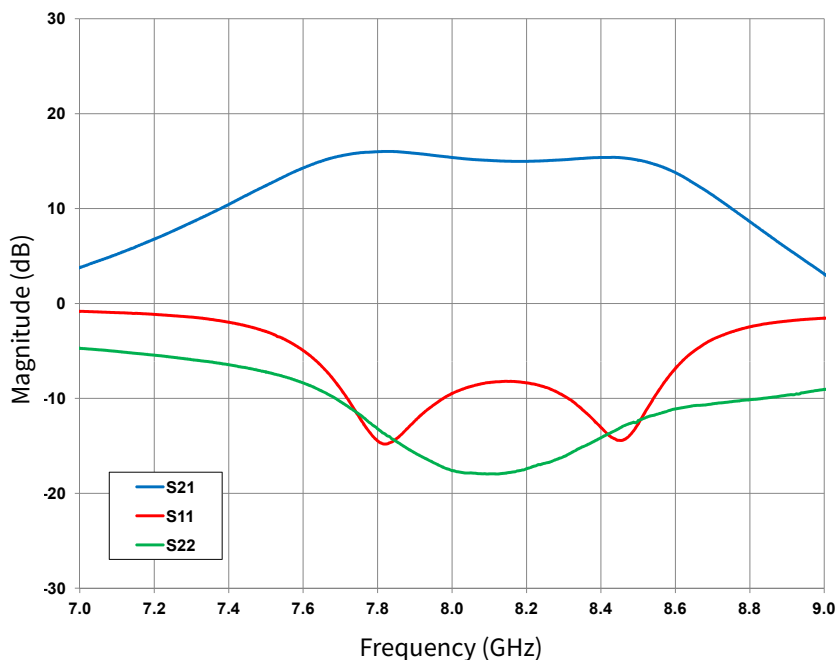

Figure 5. Typical Small Signal Response of CGHV1F006S-AMP2 Application Circuit

$$V_{DD} = 40\text{ V}, I_{DQ} = 60\text{ mA}$$

Typical Performance in Application Circuit CGHV1F006S-AMP2

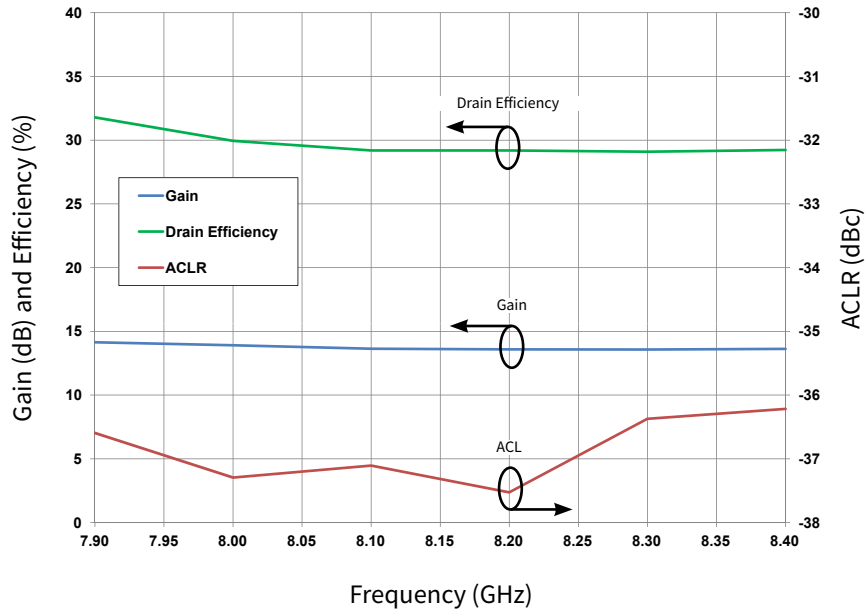

Figure 6. Typical OQPSK Response
 $V_{DD} = 40\text{ V}$, $I_{DQ} = 60\text{ mA}$, 1.6 MSPS, $P_{OUT} = 33\text{ dBm}$

Typical Performance in Application Circuit CGHV1F006S-AMP2

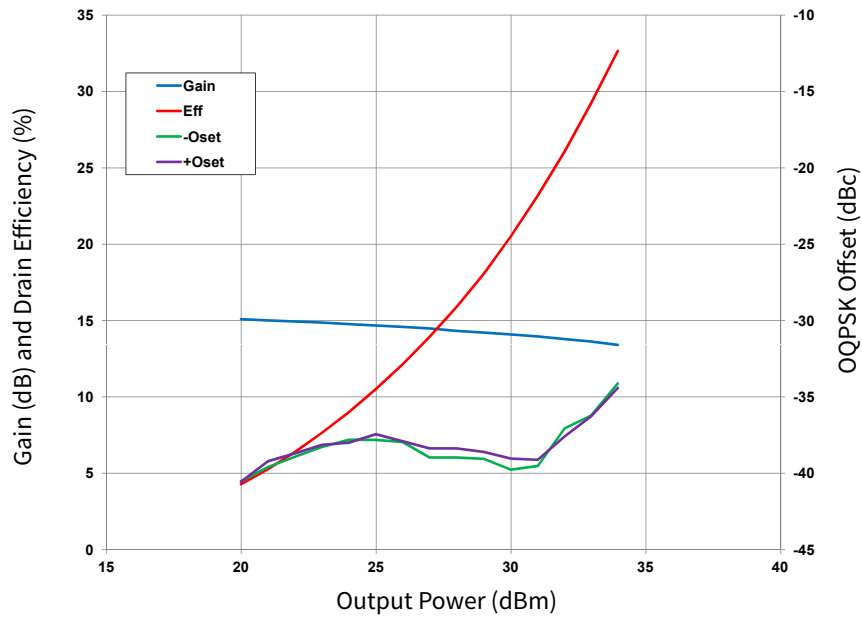

Figure 7. OQPSK Transfer Response
 $V_{DD} = 40\text{ V}$, $I_{DQ} = 60\text{ mA}$, 1.6 MSPS, Frequency = 8.4 GHz

Typical Performance in Application Circuit CGHV1F006S-AMP2

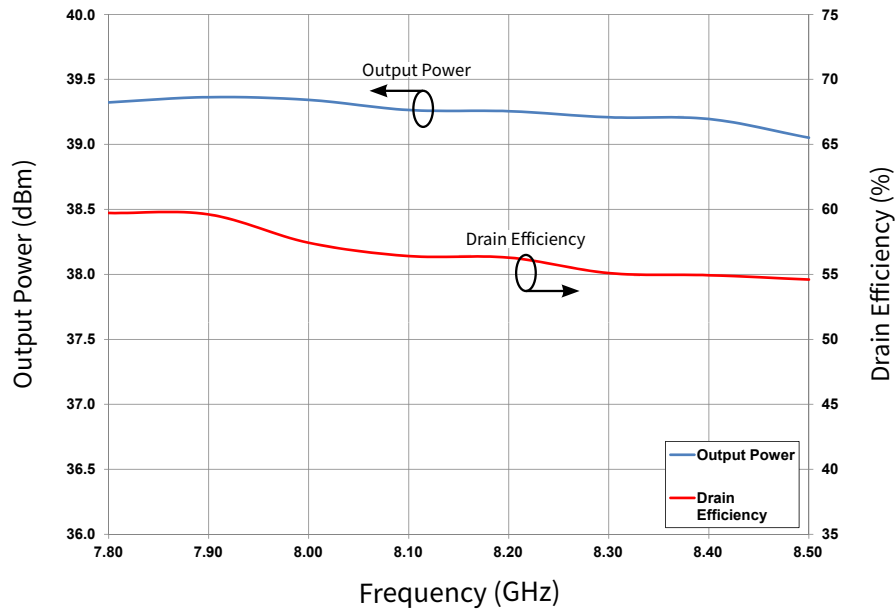
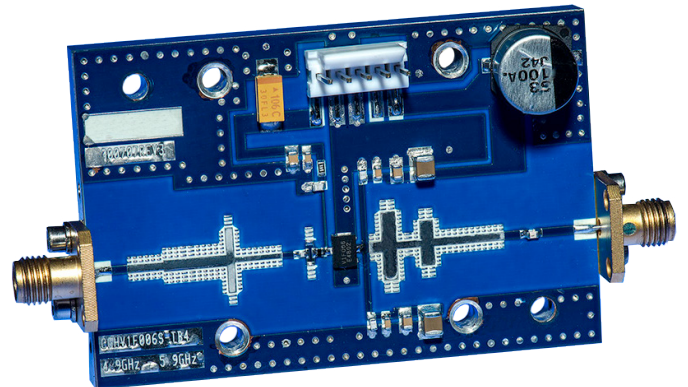

Figure 8. Typical Pulsed Power Response
 $V_{DD} = 40\text{ V}$, $I_{DQ} = 60\text{ mA}$, $100\ \mu\text{s}$, 10% Duty, $P_{IN} = 28\text{ dBm}$

CGHV1F006S-AMP2 Application Circuit Bill of Materials, SATCOM

Designator	Description	Qty
R1	RES, 15 ohm, +/-1%, 1/16 W, 0402	1
R2	RES, 100 ohm, +/-1%, 1/16 W, 0603	1
C3, C8	CAP, 1.0 pF, ±0.05 pF, 0402, ATC	2
C14	CAP, 1.0 pF, ±5%, 0603, ATC	1
C1	CAP, 1.2 pF, ±5%, 0603, ATC	1
C2	CAP, 1.6 pF, ±5%, 0402, ATC	1
C4	CAP, 10 pF, ±5%, 0603, ATC	1
C5, C10	CAP, 470 pF, 5%, 100V, 0603, X	2
C6, C11	CAP, 33000 pF, 0805, 100V, X7R	2
C7	CAP, 10 μF, 16 V, TANTALUM	1
C9	CAP, 20 pF, ±5%, 0603, ATC	1
C12	CAP, 1.0 μF, 100V, 10%, X7R, 1210	1
C13	CAP, 33 μF, 20%, G CASE	1
J1, J2	CONN, SMA, PANEL MOUNT JACK, FLANGE	2
	PCB, RT5880, 0.020" THK, CGHV1F006S	1
	BASEPLATE, AL, 2.60 X 1.70 X 2.50	1
J3	HEADER RT>PLZ .1CN LK 5POS	1
	2-56 SOC HD SCREW 1/4 SS	4
	#2 SPLIT LOCKWASHER SS	4
Q1	QFN TRANSISTOR CGHV1F006S	1

CGHV1F006S-AMP2 Application Circuit



CGHV1F006S-AMP2 Application Circuit Schematic, SATCOM

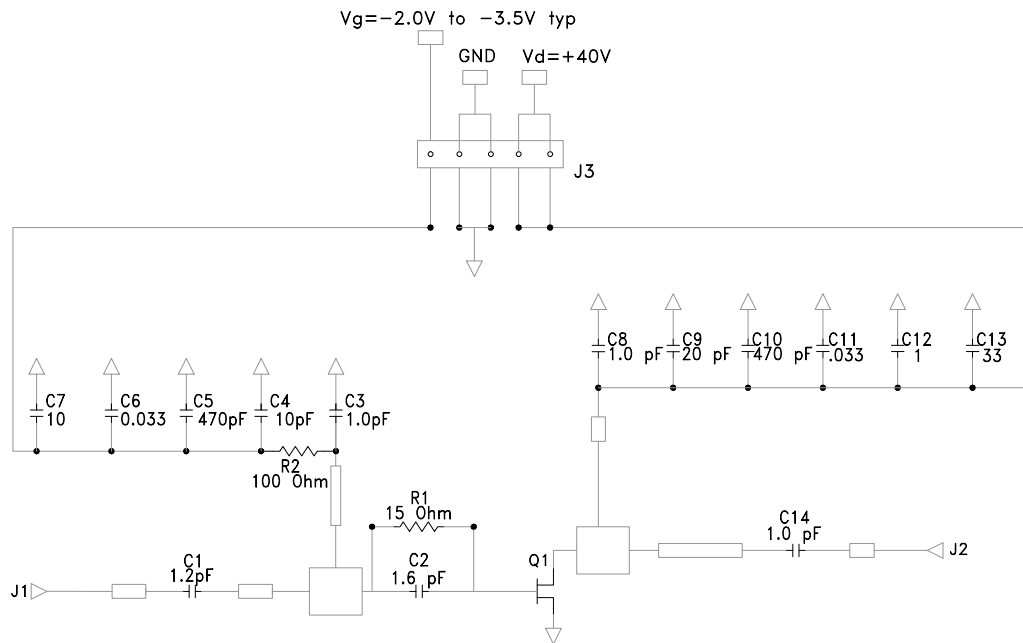

CGHV1F006S-AMP2 Application Circuit Outline, SATCOM

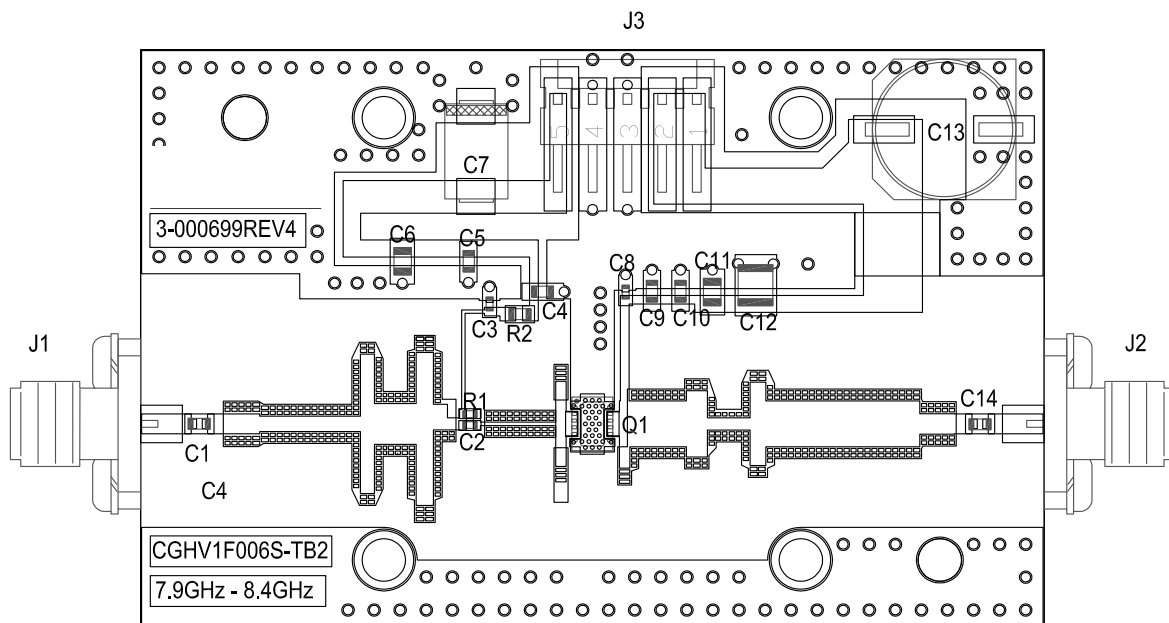

Electrical Characteristics When Tested in CGHV1F006S-AMP3 at X-Band, RADAR

Characteristics	Symbol	Min.	Typ.	Max.	Units	Conditions
RF Characteristics¹ ($T_c = 25^\circ\text{C}$, $F_0 = 8.5 - 9.6\text{ GHz}$ unless otherwise noted)						
Gain	G	-	14.5	-	dB	$V_{DD} = 40\text{ V}$, $I_{DQ} = 60\text{ mA}$, $P_{IN} = 0\text{ dBm}$
Output Power ²	P_{OUT}	-	38.5	-	dBm	$V_{DD} = 40\text{ V}$, $I_{DQ} = 60\text{ mA}$, $P_{IN} = 28\text{ dBm}$
Drain Efficiency ²	η	-	52	-	%	
Output Mismatch Stress ²	VSWR	-	10 : 1	-	Ψ	

Notes:

¹ Measured in CGHV1F006S-AMP3 Application Circuit

² Pulsed 100 μs , 10% duty cycle

Typical Performance in Application Circuit CGHV1F006S-AMP3 at X-Band, RADAR

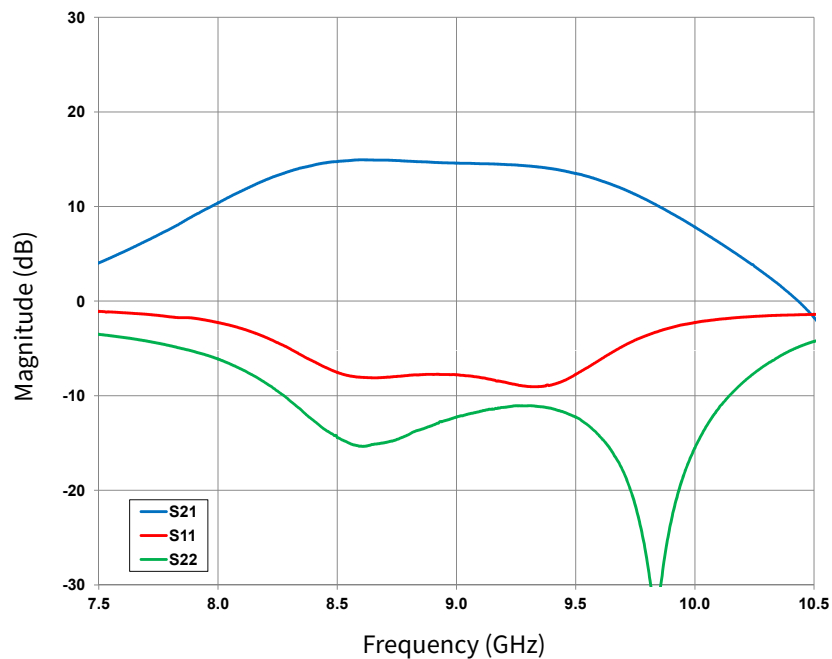

Figure 9. Typical Small Signal Response

$$V_{DD} = 40\text{ V}, I_{DQ} = 60\text{ mA}$$

Typical Performance in Application Circuit CGHV1F006S-AMP3

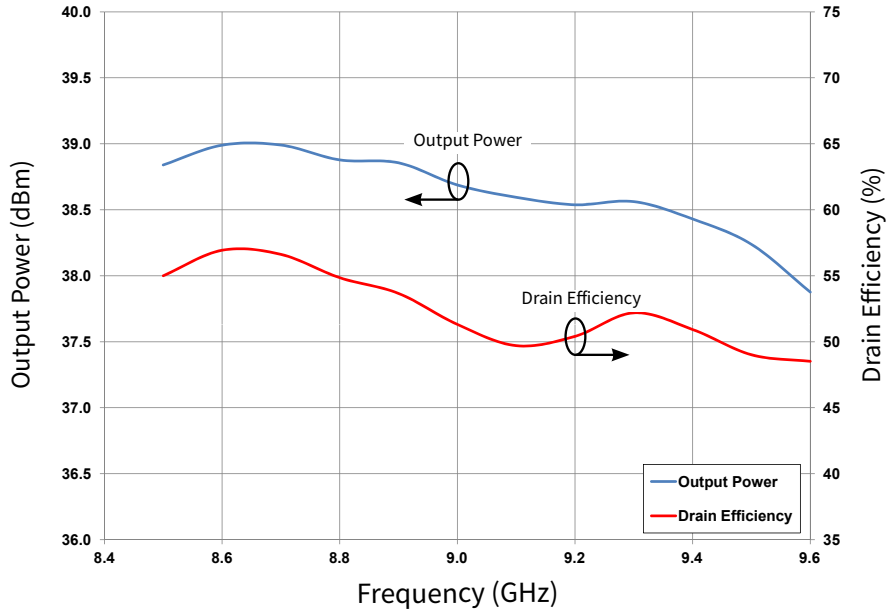
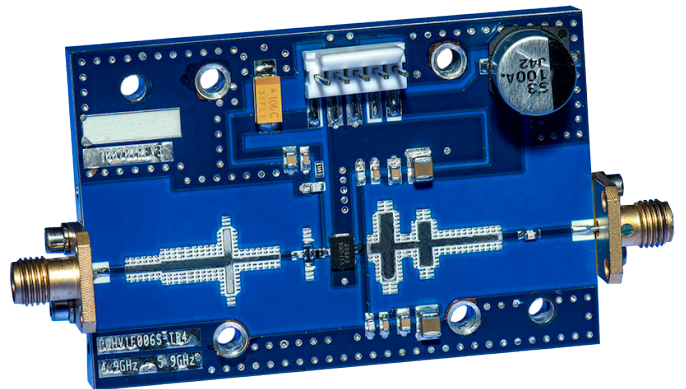

Figure 10. Typical Pulsed Power Response
 $V_{DD} = 40\text{ V}$, $I_{DQ} = 60\text{ mA}$, $100\ \mu\text{s}$, 10% Duty, $P_{IN} = 28\text{ dBm}$

**CGHV1F006S-AMP3 Application Circuit
 Bill of Materials, RADAR**

Designator	Description	Qty
R1	RES, 15 ohm, +/-1%, 1/16 W, 0402	1
R2	RES, 100 ohm, +/-1%, 1/16 W, 0603	1
C1, C14	CAP, 1.0 pF, ±0.05 pF, 0603, ATC	2
C2	CAP, 1.0 pF, ±0.05 pF, 0402, ATC	1
C3, C8	CAP, 0.8 pF, ±0.05 pF, 0402, ATC	2
C4	CAP, 10 pF, ±5%, 0603, ATC	1
C5, C10	CAP, 470 pF, 5%, 100 V, 0603, X	2
C6, C11	CAP, 33000 pF, 0805, 100V, X7R	2
C7	CAP, 10 μF, 16 V, TANTALUM	1
C9	CAP, 20 pF, ±5%, 0603, ATC	1
C12	CAP, 1.0 μF, 100V, 10% X7R, 1210	1
C13	CAP, 33 μF, 20%, G CASE	1
J1, J2	CONN, SMA, PANEL MOUNT JACK, FLANGE	2
J3	HEADER RT>PLZ .1CEN LK 5POS	1
Q1	QFN TRANSISTOR CGHV1F006S	1

CGHV1F006S-AMP3 Application Circuit



CGHV1F006S-AMP3 Application Circuit Schematic, RADAR

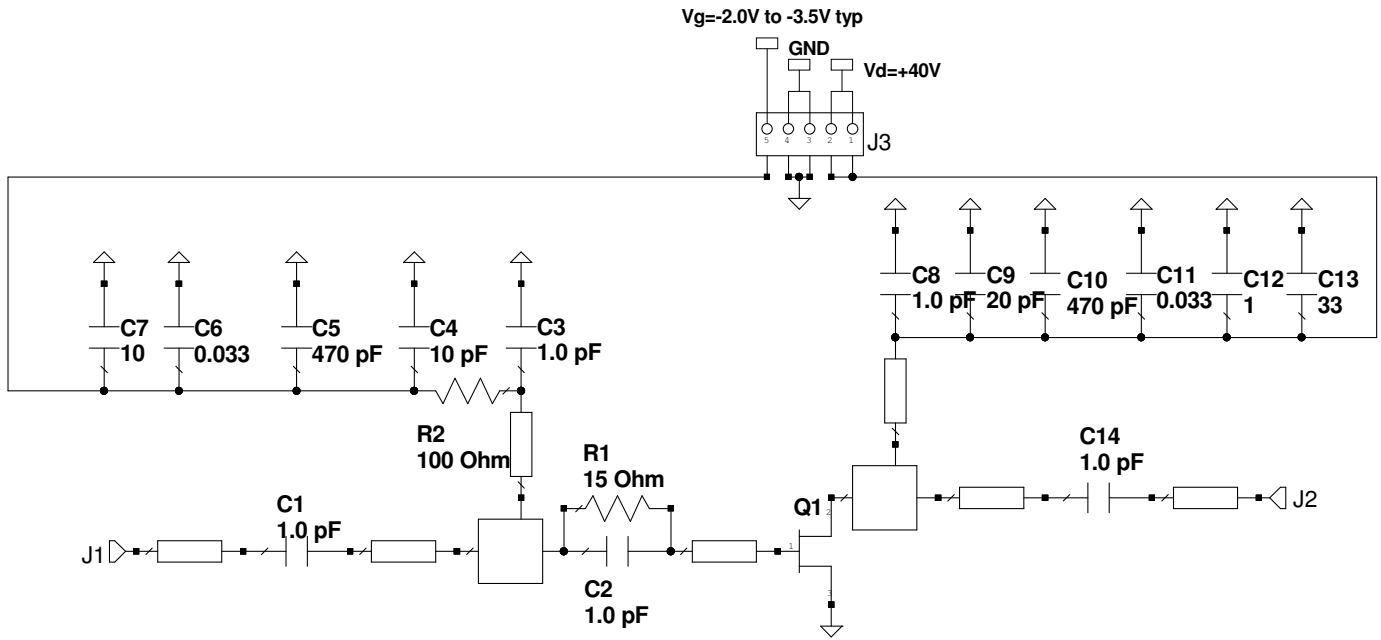

CGHV1F006S-AMP3 Application Circuit Outline, RADAR

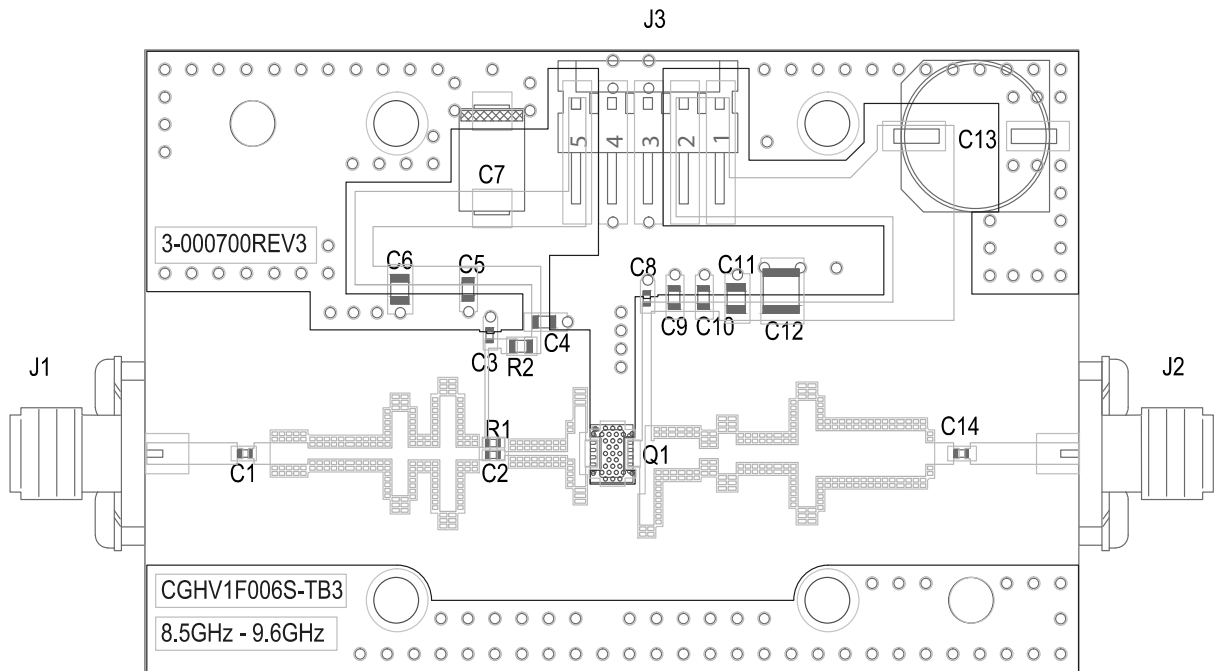

Electrical Characteristics When Tested in CGHV1F006S-AMP4 at 802.11

Characteristics	Symbol	Min.	Typ.	Max.	Units	Conditions
RF Characteristics¹ ($T_c = 25^\circ\text{C}$, $F_0 = 4.9 - 5.9$ GHz unless otherwise noted)						
Gain	G	-	13	-	dB	$V_{DD} = 20\text{ V}$, $I_{DQ} = 30\text{ mA}$, $P_{IN} = 27\text{ dBm}$
Drain Efficiency ²	η	-	27	-	%	
OQPSK ³	ACLR	-	-43	-	dBc	$V_{DD} = 20\text{ V}$, $I_{DQ} = 30\text{ mA}$, $P_{OUT} = 27\text{ dBm}$
Output Mismatch Stress ²	VSWR	-	10 : 1	-	Ψ	No damage at all phase angles, $V_{DD} = 20\text{ V}$, $I_{DQ} = 30\text{ mA}$, $P_{IN} = 27\text{ dBm}$

Notes:

¹ Measured in CGHV1F006S-AMP4 Application Circuit

² Single carrier WCDMA, 3GPP Test Model 1, G4 DPCH, 45% clipping, PAR = 7.5 dB @ 0.01% probability on CCDF

Typical Performance - CGHV1F006S-AMP4 at 802.11

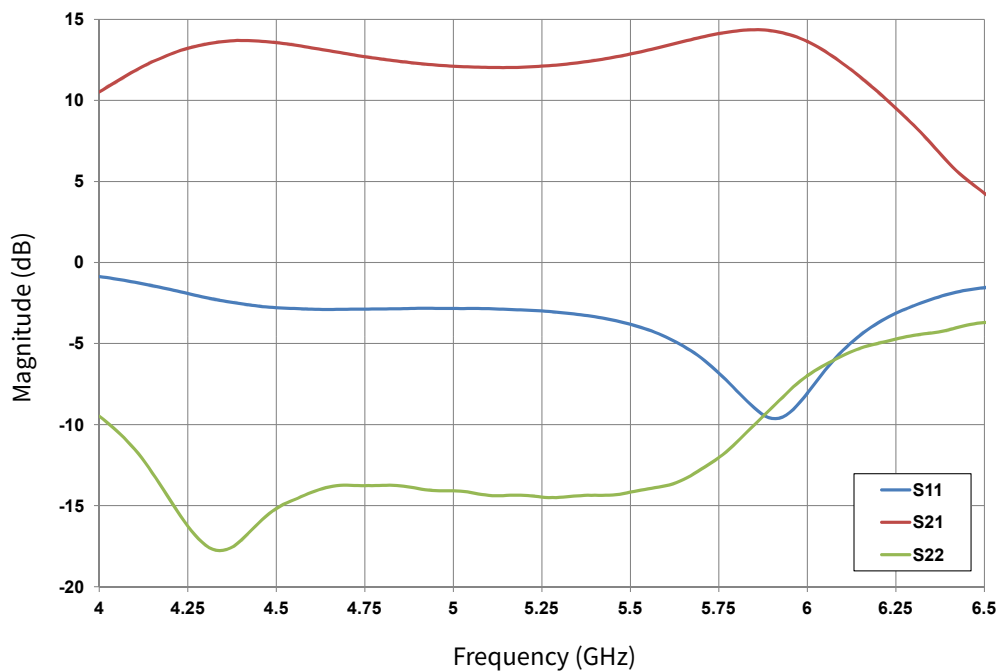

Figure 11. Typical Small Signal Response
 $V_{DD} = 20\text{ V}$, $I_{DQ} = 30\text{ mA}$

Typical Performance in Application Circuit CGHV1F006S-AMP4

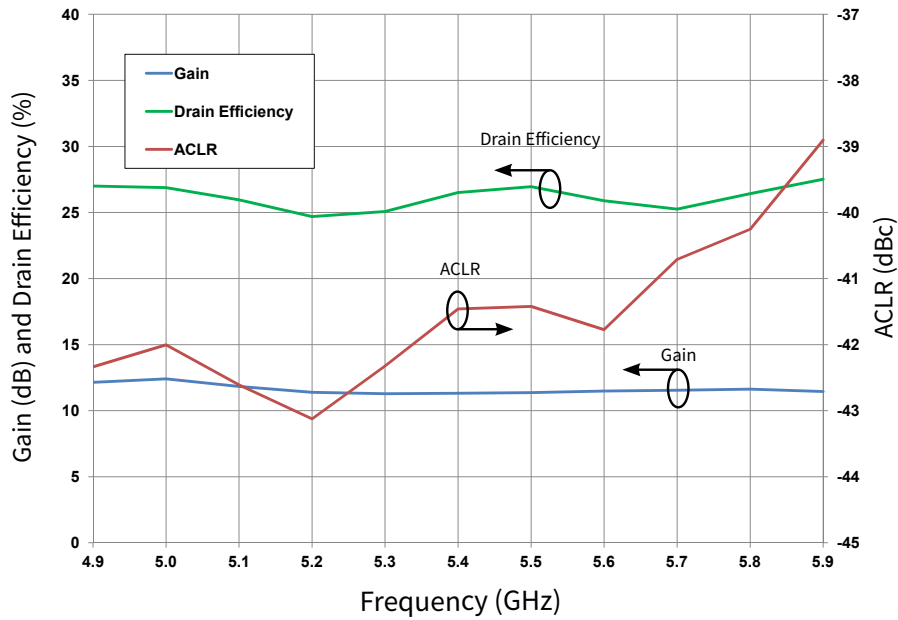
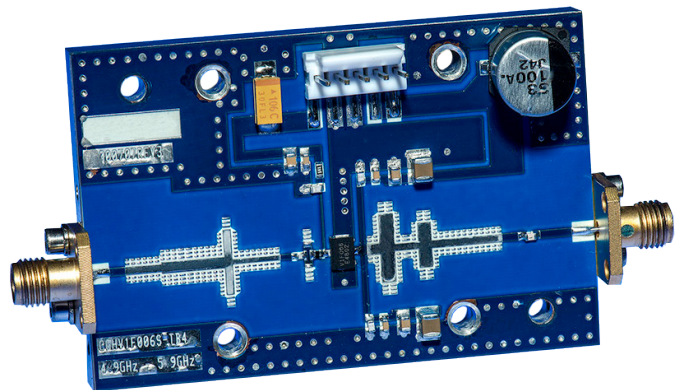

Figure 12. Typical Gain, Efficiency and WCDMA Performance vs Frequency
 $V_{DD} = 20\text{ V}$, $I_{DQ} = 30\text{ mA}$, $P_{OUT} = 27\text{ dBm}$

**CGHV1F006S-AMP4 Application Circuit
 Bill of Materials at 802.11**

Designator	Description	Qty
R1, R3	RES, 1 ohm, +/-1%, 1/16 W, 0402	2
R2	RES, 51.1. ohm, +/-1%, 1/16W, 0603	1
C2, C6, C11	CAP, 1.8 pF, +/-0.1 pF, 0603, ATC	3
C1	CAP, 0.2 pF, +/-0.05 pF, 0402, ATC	1
C3, C7, C12	CAP, 470 pF, 5%, 100 V, 0603, X	3
C4, C8, C13	CAP, 33000 pF, 0805, 100 V, X7R	3
C5	CAP, 10 μF, 16 V, TANTALUM	1
C15	CAP, 6.8 pF, ±0.25 pF, 100 V, 0603	1
C9, C14	CAP, 1.0 μF, 100V, 10% X7R, 1210	2
C10	CAP, 33 μF, 20%, G CASE	1
J1, J2	CONN, SMA, PANEL MOUNT JACK, FLANGE	2
	PCB, RO4350B, 0.020" THK, CGHV1F006S	1
	BASEPLATE, CGH35015, 2.60 X 1.7	1
J3	HEADER RT>PLZ .1CEN LK 5POS	1
	2-56 SOC HD SCREW 1/4 SS	4
	#2 SPLIT LOCKWASHER SS	4
Q1	QFN TRANSISTOR CGHV1F006S	1

CGHV1F006S-AMP4 Application Circuit



CGHV1F006S-AMP4 Application Circuit Schematic, SATCOM

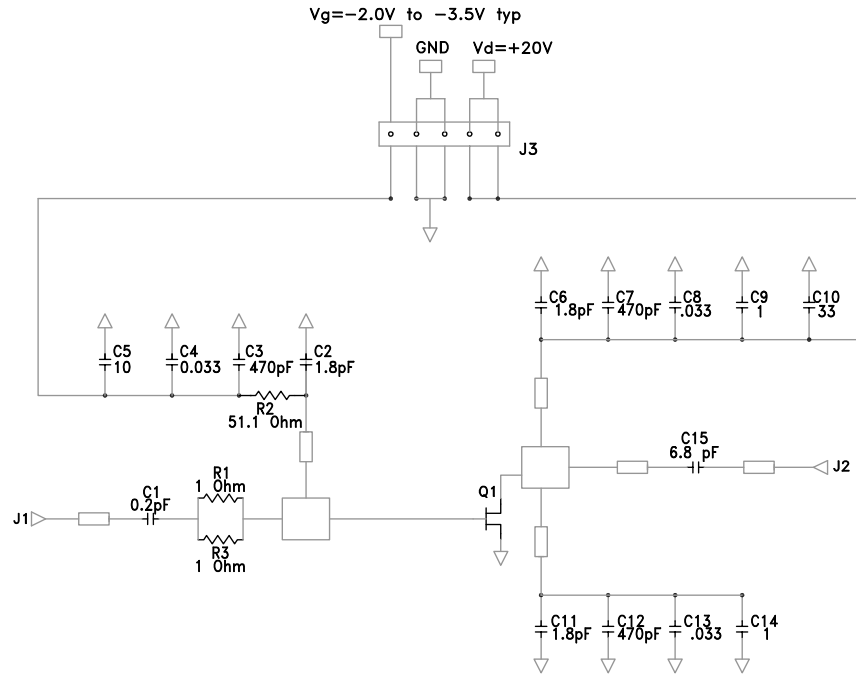

CGHV1F006S-AMP4 Application Circuit Outline, SATCOM

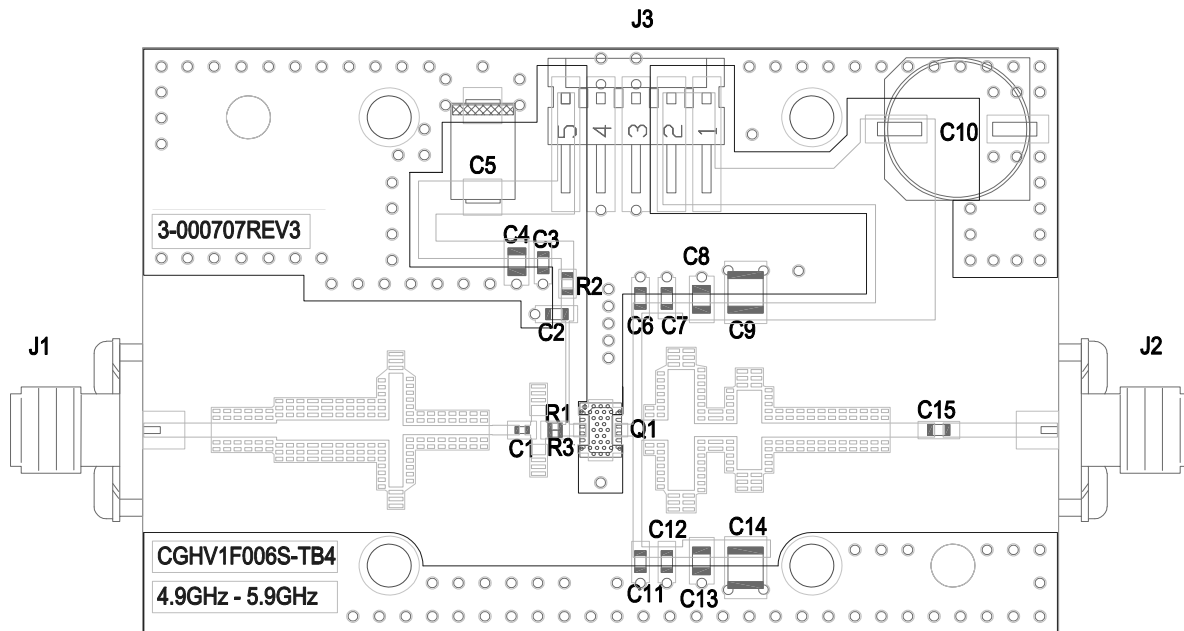

CGHV1F006S Power Dissipation De-rating Curve

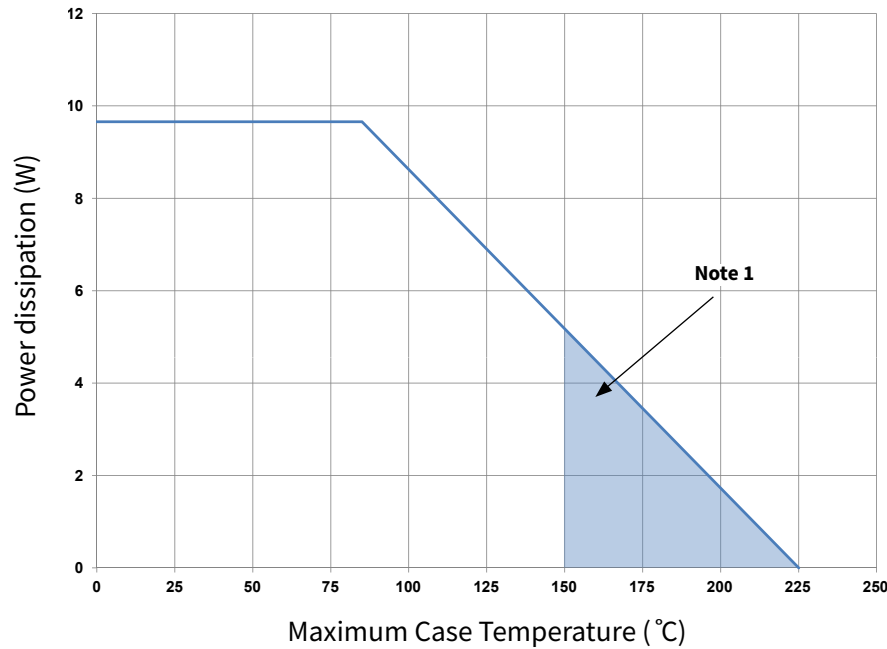

Figure 13. CGHV1F006S Transient Power Dissipation De-Rating Curve

Note:

¹ Area exceeds Maximum Case Temperature (See Page 2)

Electrostatic Discharge (ESD) Classifications

Parameter	Symbol	Class	Classification Level	Test Methodology
Human Body Model	HBM	1B	ANSI/ESDA/JEDEC JS-001 Table 3	JEDEC JESD22 A114-D
Charge Device Model	CDM	0CB	ANSI/ESDA/JEDEC JS-002 Table 3	JEDEC JESD22 C101-C

Moisture Sensitivity Level (MSL) Classification

Parameter	Symbol	Level	Test Methodology
Moisture Sensitivity Level	MSL	3 (168 hours)	IPC/JEDEC J-STD-20

Source and Load Impedances

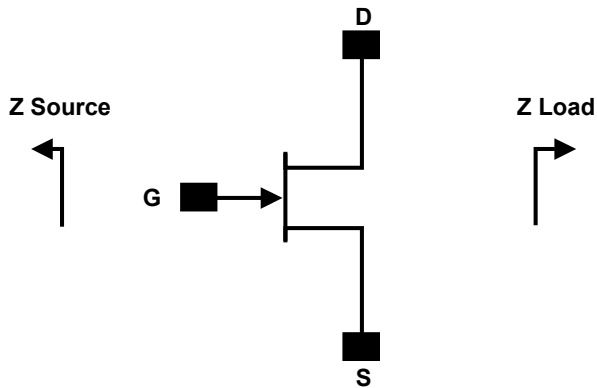

Frequency (GHz)	Z Source	Z Load
1	49.67 + j32.81	184.11 + j6.66
3	11.54 + j3.96	38.83 + j56.37
6	5.94 - j17.97	13.03 + j16.16
10	11.87 - j77.62	11.79 - j17.43
12	47.42 - j205.35	16.39 - j46.22
15	33.78 + j251.03	163.61 - j268.44

Notes:

¹ $V_{DD} = 40\text{ V}$, $I_{DQ} = 60\text{ mA}$

² Impedances are extracted from source and load pull data derived from the transistor

Product Dimensions CGHV1F006S (Package 3 x 4 DFN)

SYMBOL	COMMON DIMENSIONS			NOTE
	MIN.	NOM.	MAX.	
A	0.80	0.90	1.0	
A1	0.00	0.02	0.05	
A3	0.203 REF.			
⌀	0	—	12	2
D	4.00 BSC			
E	3.00 BSC			
Ⓢ	0.50 BSC			
N	12			3
ND	6			⚠
L	0.35	0.40	0.45	
b	0.18	0.25	0.30	⚠
D2	3.20	3.30	3.40	
E2	1.60	1.7	1.80	
K	0.20	—	—	

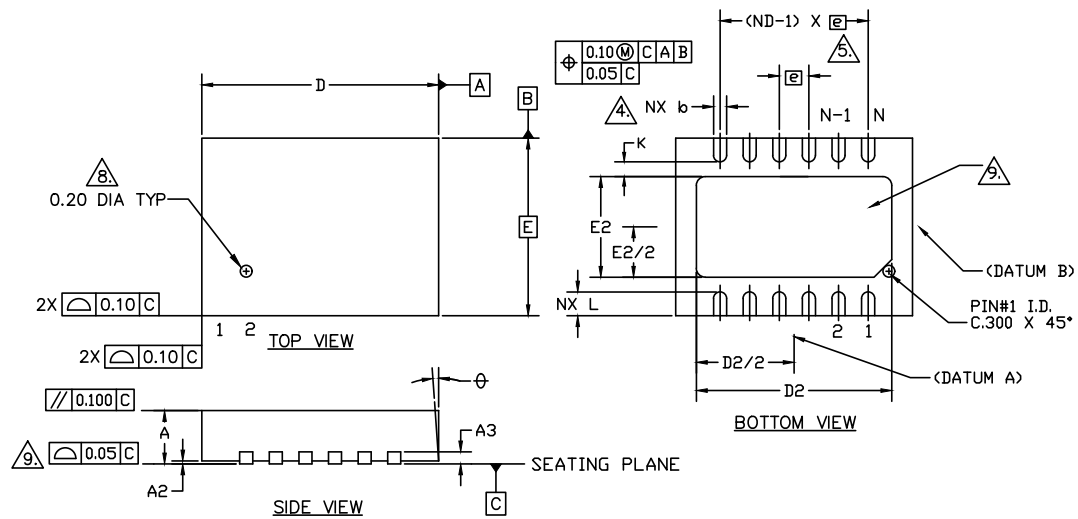

Pin	Input/Output
1	GND
2	NC
3	RF IN
4	RF IN
5	NC
6	GND
7	GND
8	NC
9	RF OUT
10	RF OUT
11	NC
12	GND

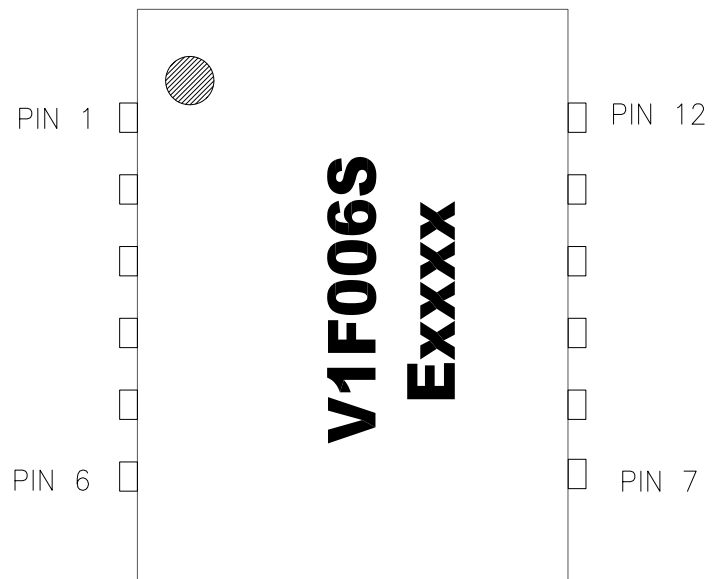

Part Number System

CGHV1F006S

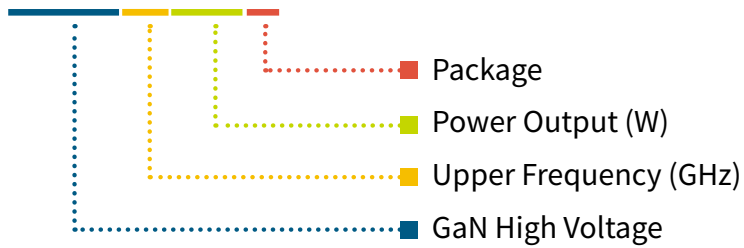

Table 1.

Parameter	Value	Units
Upper Frequency ¹	15.0	GHz
Power Output	6	W
Package	Surface Mount	-

Note:

¹ Alpha characters used in frequency code indicate a value greater than 9.9 GHz. See Table 2 for value.

Table 2.

Character Code	Code Value
A	0
B	1
C	2
D	3
E	4
F	5
G	6
H	7
J	8
K	9
Examples:	1A = 10.0 GHz 2H = 27.0 GHz

Product Ordering Information

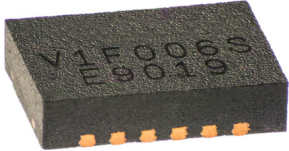
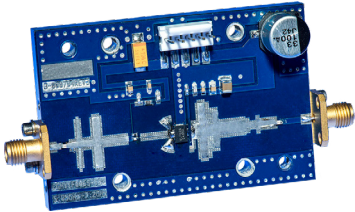
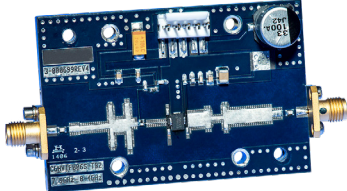
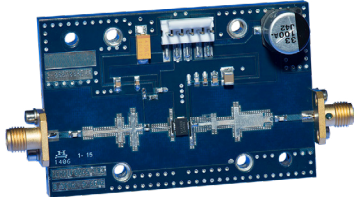
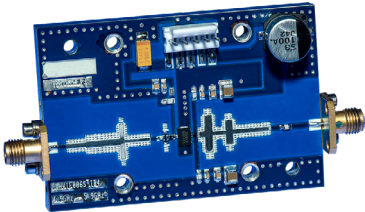
Order Number	Description	Unit of Measure	Image
CGHV1F006S	GaN HEMT	Each	
CGHV1F006S-AMP1	Test board with GaN HEMT installed, 5.85 - 7.2 GHz, 50 V C-Band under OQPSK	Each	
CGHV1F006S-AMP2	Test board with GaN HEMT installed, 7.9 - 8.4 GHz, 28 V X-Band SATCOM	Each	
CGHV1F006S-AMP3	Test board with GaN HEMT installed, 8.5 - 9.6 GHz, 28 V X-Band RADAR	Each	
CGHV1F006S-AMP4	Test board with GaN HEMT installed, 4.9 - 5.9 GHz, 50 V 802.11	Each	

Notes & Disclaimer

MACOM Technology Solutions Inc. ("MACOM"). All rights reserved.

These materials are provided in connection with MACOM's products as a service to its customers and may be used for informational purposes only. Except as provided in its Terms and Conditions of Sale or any separate agreement, MACOM assumes no liability or responsibility whatsoever, including for (i) errors or omissions in these materials; (ii) failure to update these materials; or (iii) conflicts or incompatibilities arising from future changes to specifications and product descriptions, which MACOM may make at any time, without notice. These materials grant no license, express or implied, to any intellectual property rights.

THESE MATERIALS ARE PROVIDED "AS IS" WITH NO WARRANTY OR LIABILITY, EXPRESS OR IMPLIED, RELATING TO SALE AND/OR USE OF MACOM PRODUCTS INCLUDING FITNESS FOR A PARTICULAR PURPOSE, MERCHANTABILITY, INFRINGEMENT OF INTELLECTUAL PROPERTY RIGHT, ACCURACY OR COMPLETENESS, OR SPECIAL, INDIRECT, INCIDENTAL, OR CONSEQUENTIAL DAMAGES WHICH MAY RESULT FROM USE OF THESE MATERIALS.

MACOM products are not intended for use in medical, lifesaving or life sustaining applications. MACOM customers using or selling MACOM products for use in such applications do so at their own risk and agree to fully indemnify MACOM for any damages resulting from such improper use or sale.

Looking for pricing, stock, or lifecycle information?

Click below to explore more details on WIN SOURCE:

- ⊖ [View CGHV1F006S on WIN SOURCE](#)
- ⊖ [MACOM Technology Solutions Information](#)

Optimize Your Supply Chain with WIN SOURCE Solutions

- ✓ Global Sourcing Solution
- ✓ Obsolete Management
- ✓ Cost Control Management
- ✓ Shortage Management
- ✓ Alternative Solution
- ✓ Excess Inventory Management