

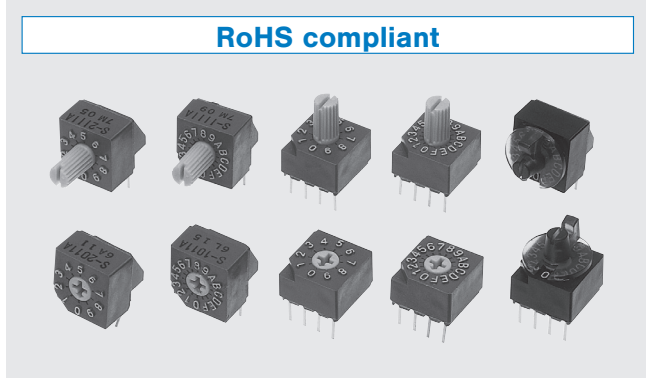

**THE DATASHEET OF  
S-1030A**



# ROTARY CODED SWITCHES **S-1000A/2000A**



## FEATURES

- RoHS compliant
- Protection against dust and whole cleaning after soldering is possible
- Pin compatible with conventional DIP switches
- Translucent knob with flange type (S-1200A/2200A series)
  - Distinguished visibility with translucent flange
  - Settable with fingers or screwdriver
- Resin materials are UL Recognized 94V-2 or 94HB

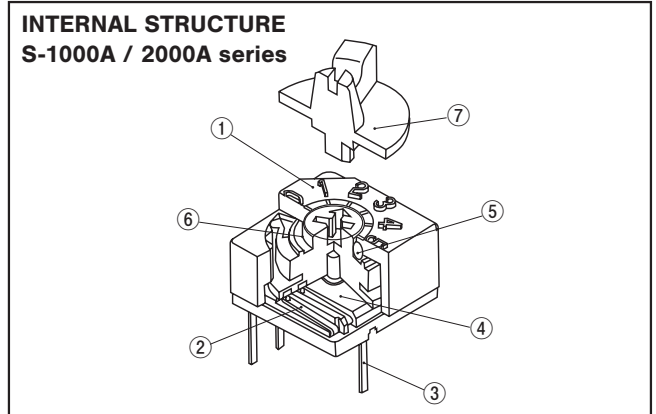

Part name	Material
① Housing	Polybutyleneterephthalate
② Contact	Copper alloy, Gold-plated
③ Terminal pin	
④ Base	Polybutyleneterephthalate
⑤ "O" ring	Silicone rubber
⑥ Insert rotor	Rotor : Polyoxymethylene Pattern : Copper alloy, Gold-plated
⑦ Translucent knob with	PAR (Polyarylate) ※ S-12□□A/22□□A only

## PART NUMBER DESIGNATION

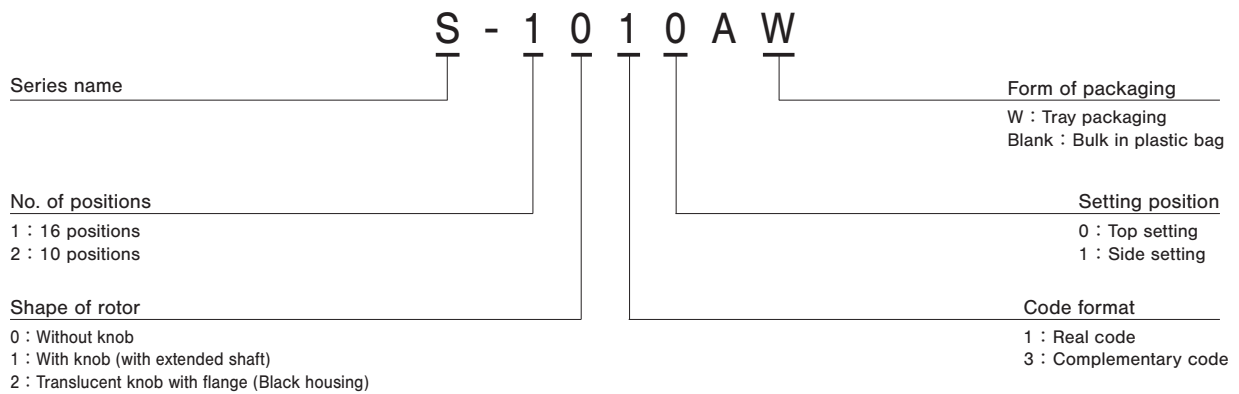

※ Please refer to the LIST OF PART NUMBERS when placing orders.

# S-1000A/2000A

## ROTARY CODED SWITCHES





### LIST OF PART NUMBERS

Shape		Form of packaging	Binary coded decimal		Binary coded hexadecimal		Packaging quantity
			Real code	Complementary code	Real code	Complementary code	
Top setting	Without knob	Tray packaging	S-2010AW	S-2030AW	S-1010AW	S-1030AW	50 pcs./tray
		Plastic bag	S-2010A	S-2030A	S-1010A	S-1030A	25 pcs./pack
	With knob	Tray packaging	S-2110AW	S-2130AW	S-1110AW	S-1130AW	50 pcs./tray
		Plastic bag	S-2110A	S-2130A	S-1110A	S-1130A	25 pcs./pack
	Translucent knob with flange	Tray packaging	S-2210AW	S-2230AW	S-1210AW	S-1230AW	50 pcs./tray
		Plastic bag	S-2210A	S-2230A	S-1210A	S-1230A	25 pcs./pack
Side setting	Without knob	Tray packaging	S-2011AW	S-2031AW	S-1011AW	S-1031AW	50 pcs./tray
		Plastic bag	S-2011A	S-2031A	S-1011A	S-1031A	25 pcs./pack
	With knob	Tray packaging	S-2111AW	S-2131AW	S-1111AW	S-1131AW	50 pcs./tray
		Plastic bag	S-2111A	S-2131A	S-1111A	S-1131A	25 pcs./pack
	Translucent knob with flange	Tray packaging	S-2211AW	S-2231AW	S-1211AW	S-1231AW	50 pcs./tray
		Plastic bag	S-2211A	S-2231A	S-1211A	S-1231A	25 pcs./pack

※ Verify the above part numbers when placing orders.  
Tray version can be supplied only in tray units.

### TERMINAL CONNECTION / P.C.B. THROUGH HOLE DIMENSIONS

(Unit: mm)

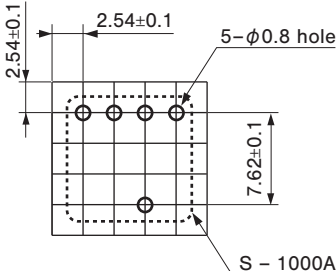
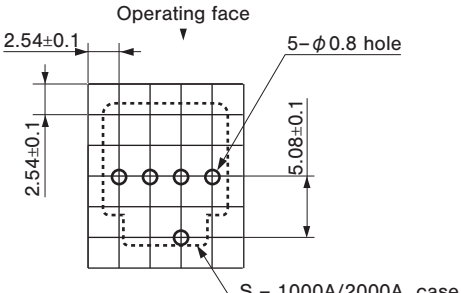
	Top setting	Side setting
Terminal pin layout (Bottom view)	<p>Real code</p>  <p>Complementary code</p> 	<p>Operating face of real code</p>  <p>Operating face of complementary code</p> 
P.C.B. dimensions (Bottom view)		

### CODE FORMAT

No. of positions		S-1000A series (16 positions)																
		S-2000A series (10 positions)										A	B	C	D	E	F	
Position		0	1	2	3	4	5	6	7	8	9	A	B	C	D	E	F	
Code	Real code	8								●	●	●	●	●	●	●	●	
		4					●	●	●	●				●	●	●	●	
		2			●	●			●	●			●	●			●	●
		1		●		●			●	●		●		●		●		●
	Complementary code	8	●	●	●	●	●	●	●	●								
		4	●	●	●	●					●	●	●	●				
		2	●	●			●	●			●	●			●	●		
	1	●		●		●	●		●			●		●		●		

● ...Contact closed

# S-1000A/2000A

## ROTARY CODED SWITCHES

### STANDARD SPECIFICATIONS

Circuit type	BCD (Real code, complementary code) BCH (Real code, complementary code)
Operating temp. range	-40 ~ 85 °C
Storage temp. range	
Sealing	Washable by "O" ring ※ Please refer to page 149,150
Net weight	Approx. 0.87 g (S-1010A, S-1030A, S-2010A, S-2030A) Approx. 1.13 g (S-1011A, S-1031A, S-2011A, S-2031A) Approx. 0.97 g (S-1110A, S-1130A, S-2110A, S-2130A) Approx. 1.23 g (S-1111A, S-1131A, S-2111A, S-2131A) Approx. 1.02 g (S-1210A, S-1230A, S-2210A, S-2230A) Approx. 1.28 g (S-1211A, S-1231A, S-2211A, S-2231A)

### MECHANICAL CHARACTERISTICS

No. of positions	16 (S-1000A), 10 (S-2000A)
Adjustment torque	13 mN·m {133 gf·cm} minimum
Stepping angle	22.5° (S-1000A), 36° (S-2000A)
Terminal strength	15 N {1.53 kgf} minimum
Solderability	245 ± 3 °C, 2 ~ 3 s
Soldering heat	Flow : 260 ± 3 °C as the temperature in a pot of molten solder, immersion from head of terminal to backside of board, 5 ~ 6 s, two times maximum
	Manual soldering : 380 ± 10 °C, 3 ~ 4 s

{ } : Reference only

### ELECTRICAL CHARACTERISTICS

Contact rating Non-switching Switching Minimum	DC50 V 100 mA DC5 V 100 mA DC20 mV 1 μA
Contact resistance	100 mΩ maximum
Insulation resistance	1000 MΩ (DC100 V) minimum
Dielectric strength	AC300 V, 60 s

### ENVIRONMENTAL CHARACTERISTICS

Vibration	Amplitude 1.5 mm or Acceleration 98 m/s <sup>2</sup> , 10-500-10 Hz, 3 directions for 2 h each
Shock	490 m/s <sup>2</sup> , 11 ms 6 directions for 3 times each
Load life	10000 steps DC5 V, 100 mA
Humidity (Steady state)	Resistance load DC50V 100mA 60 °C, Relative humidity 90 ~ 95 %, 1000 h
High temp. exposure	85 °C, 1000 h
Low temp. exposure	-40 °C, 96 h
Thermal shock	-40 (0.5 h) ~ 85 °C (0.5 h), 5 cycles

# S-1000A/2000A

## ROTARY CODED SWITCHES

### OUTLINE DIMENSIONS

Unless otherwise specified, tolerance:  $\pm 0.3$  (Unit: mm)

(S-1000A series)

- S-1010A
  - S-1030A
- Top setting

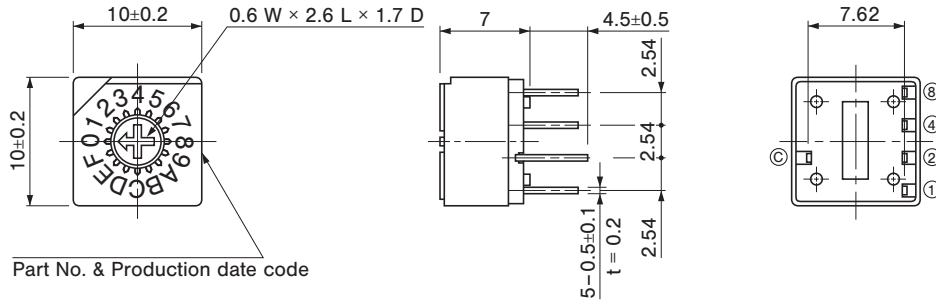

- S-1011A
  - S-1031A
- Side setting

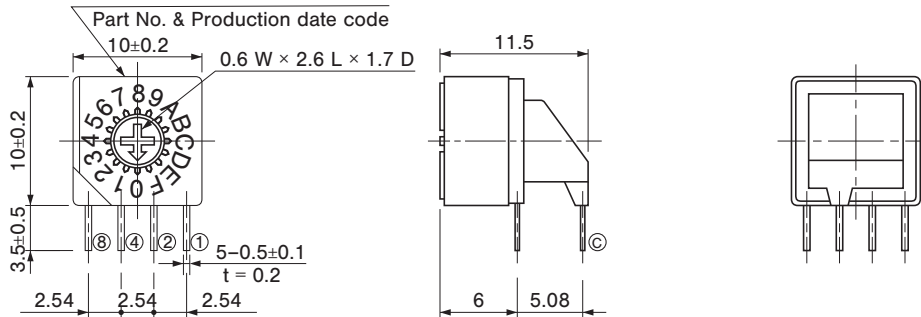

- S-1110A
  - S-1130A
- Top setting

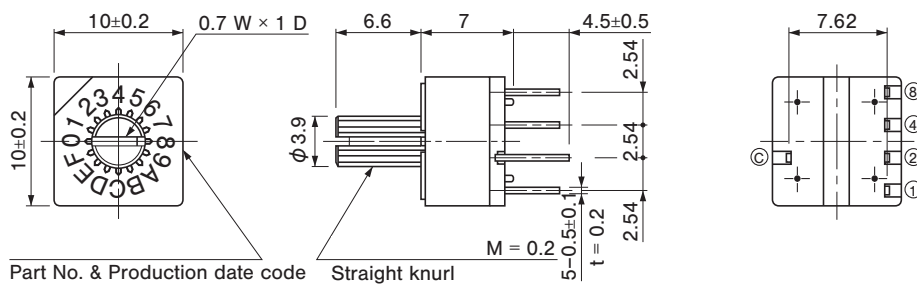

- S-1111A
  - S-1131A
- Side setting

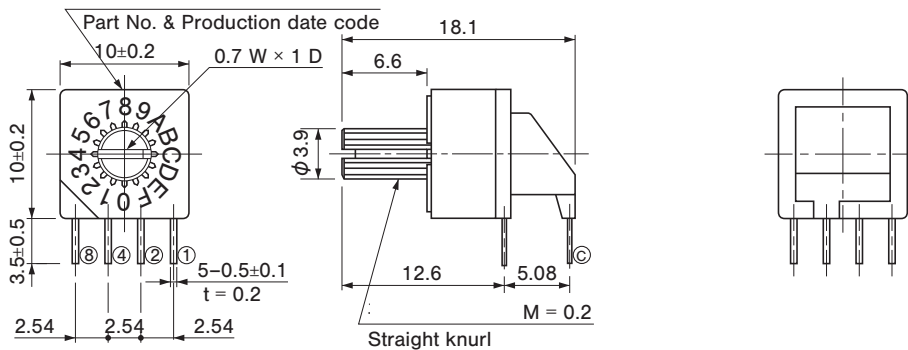

# S-1000A/2000A

## ROTARY CODED SWITCHES

### OUTLINE DIMENSIONS

Unless otherwise specified, tolerance:  $\pm 0.3$  (Unit: mm)

#### (S-2000A series)

- S-2010A
  - S-2030A
- Top setting

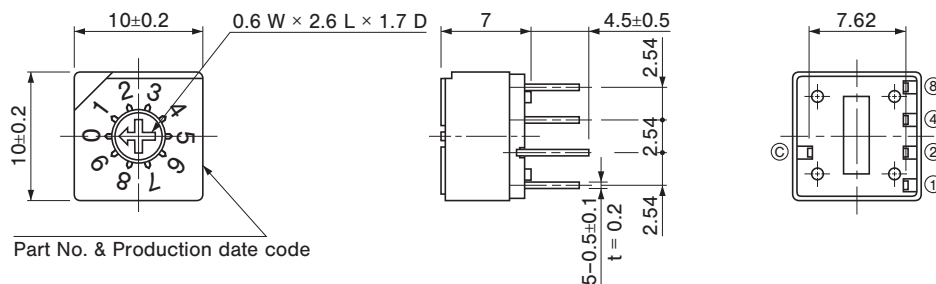

- S-2011A
  - S-2031A
- Side setting

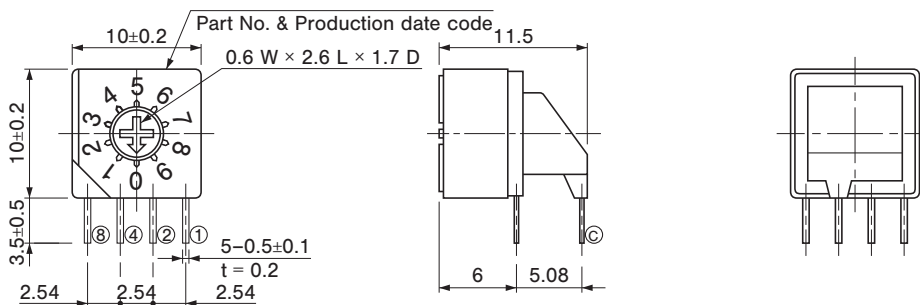

- S-2110A
  - S-2130A
- Top setting

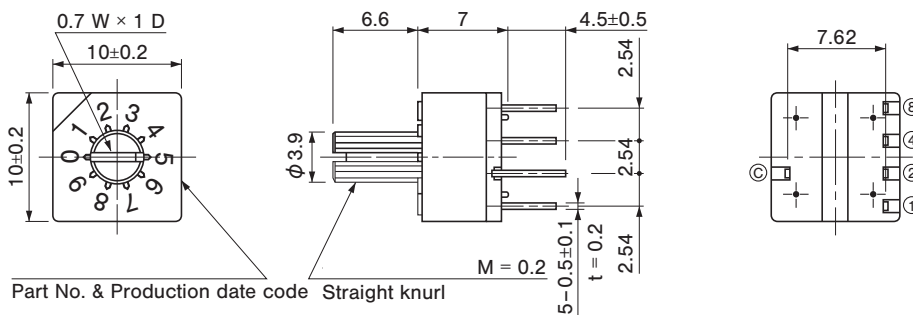

- S-2111A
  - S-2131A
- Side setting

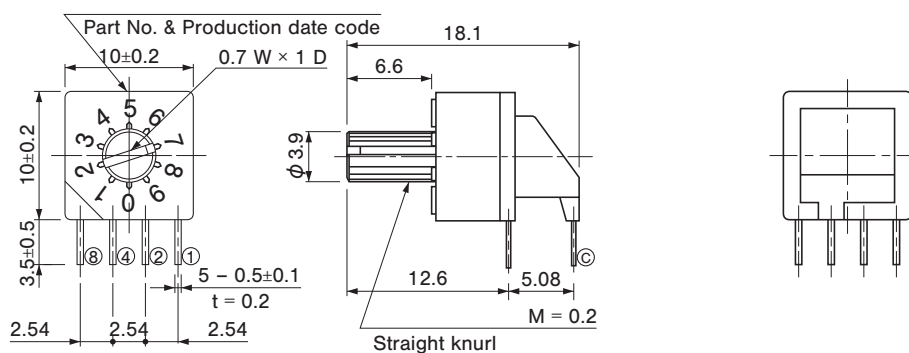

# S-1000A/2000A

## ROTARY CODED SWITCHES

### OUTLINE DIMENSIONS

#### (S-1200A/2200A series)

Unless otherwise specified, tolerance:  $\pm 0.3$  (Unit: mm)

- S-1210A
  - S-1230A
- Top setting

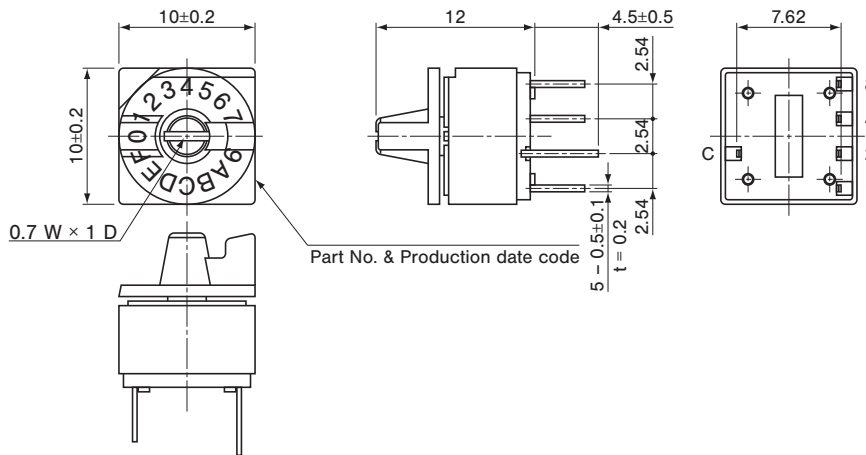

- S-1211A
  - S-1231A
- Side setting

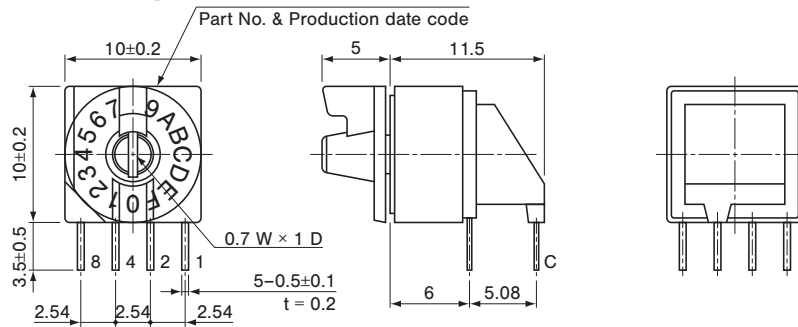

- S-2210A
  - S-2230A
- Top setting

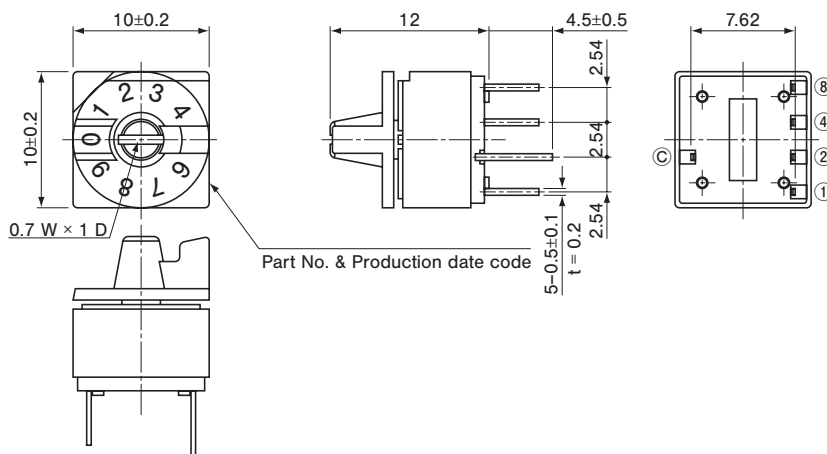

- S-2211A
  - S-2231A
- Side setting

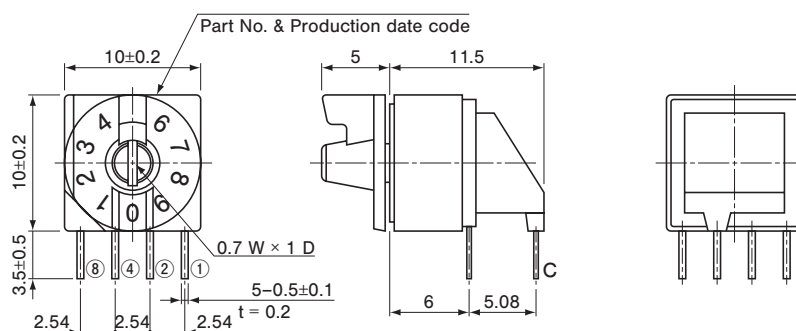

# S-1000A/2000A

## ROTARY CODED SWITCHES

### ■ Snap-in terminal pin with translucent knob with flange (Made to order basis)

#### ● S-1200AK and S-2200AK

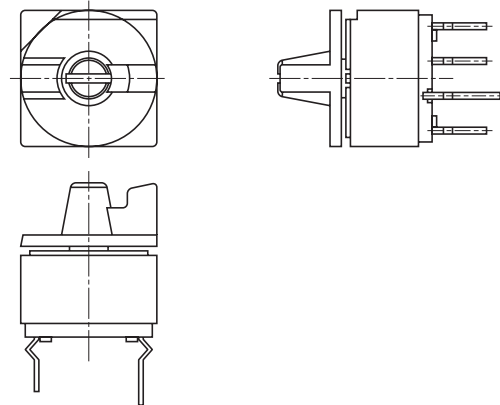
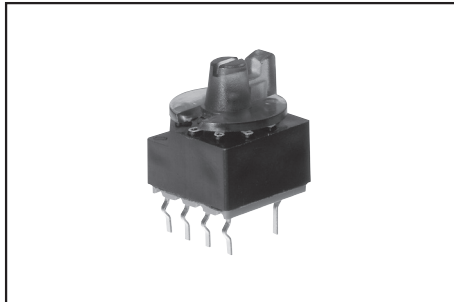

### ■ PACKAGING SPECIFICATIONS

#### <Tray packaging specifications>

- Tray version is packaged in 50 pcs. per tray. Orders will be accepted for units of 50 pcs., i. e., 50, 100, 150 pcs. etc.
- Tray version is boxed with 10 trays.

#### <Bulk pack specifications>

- Boxing of bulk in a plastic bag is performed with 25 pcs. (standard 50 pcs.) per box.

### ■ SWITCHES WITH KNOB AS EXTENDED SHAFT

(Unit: mm)

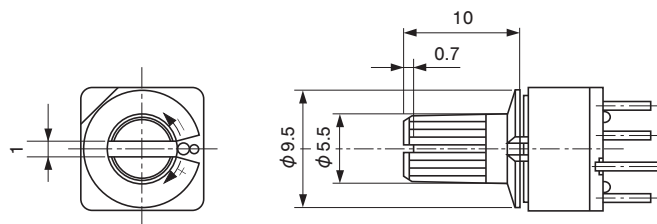
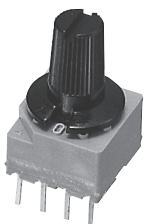



The large knob is common to S-1000A, S-2000A, SA-5000 series.

※ Knob can't be detached due to being fixed. Simple knob can't be sold.

## Looking for pricing, stock, or lifecycle information?

Click below to explore more details on WIN SOURCE:

-  [View S-1030A on WIN SOURCE](#)
-  [Nidec Copal Electronics Information](#)

## Optimize Your Supply Chain with WIN SOURCE Solutions

-  Global Sourcing Solution
-  Obsolete Management
-  Cost Control Management
-  Shortage Management
-  Alternative Solution
-  Excess Inventory Management