



**THE DATASHEET OF
PI6CG33401CZHIEX**



3.3V Very-Low-Power 4-Output PCIe Clock Generator With On-Chip Termination

Description

The DIODES PI6CG33401C is a 4-output very-low-power PCIe Gen1/Gen2/Gen3/Gen4/Gen5/Gen6 clock generator. It uses 25MHz crystal or CMOS reference as an input to generate the 100MHz low-power differential HCSL outputs with on-chip terminations. The on-chip termination can save 16 external resistors and make layout easier. An additional buffered reference output is provided to serve as a low-noise reference for other circuitry.

It uses Diodes' proprietary PLL design to achieve very-low jitter that meets PCIe Gen1/Gen2/Gen3/Gen4/Gen5/Gen6 requirements. It also provides various options such as different slew rate and amplitude through SMBUS, so users can configure the device easily to get the optimized performance for their individual boards. The device also supports selectable spread-spectrum options to reduce EMI for various applications.

Block Diagram

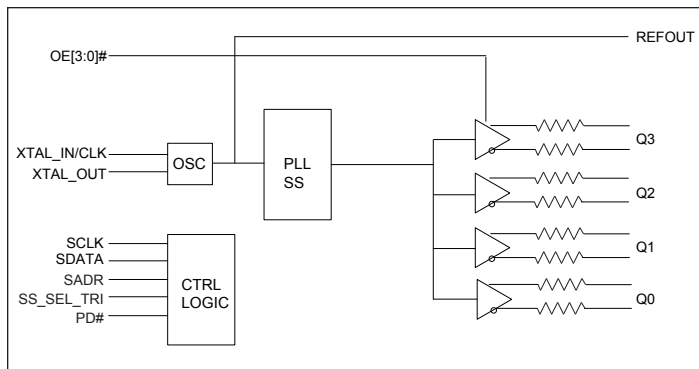

Features

- 3.3V Supply Voltage
- Crystal/CMOS Input: 25MHz
- Four Differential Low Power HCSL Outputs with On-Chip Termination
- Default $Z_{OUT} = 100\Omega$
- Individual Output Enable
- Reference CMOS Output
- Programmable Slew Rate and Output Amplitude for Each Output
- Differential Outputs Blocked until PLL is Locked
- Selectable 0%, -0.25%, or -0.5% Spread on Differential Outputs
- Strapping pins or SMBus for Configuration
- Differential Output-To-Output Skew <50ps
- Very-Low Jitter Outputs
 - Differential Cycle-To-Cycle Jitter <50ps
 - PCIe Gen1/Gen2/Gen3/Gen4/Gen5/Gen6 Compliant
 - CMOS REFOUT Phase Jitter
 - <0.3ps RMS, SSC off
 - <1.5ps RMS, SSC on
- Totally Lead-Free & Fully RoHS Compliant (Notes 1 & 2)
- Halogen and Antimony Free. “Green” Device (Note 3)
- For automotive applications requiring specific change control (i.e. parts qualified to AEC-Q100/101/104/200, PPAP capable, and manufactured in IATF 16949 certified facilities), please [contact us](https://www.diodes.com/quality/product-definitions/) or your local Diodes representative.
- Packaging (Pb-free & Green):
 - 32-lead 5mm × 5mm TQFN

Notes:

1. No purposely added lead. Fully EU Directive 2002/95/EC (RoHS), 2011/65/EU (RoHS 2) & 2015/863/EU (RoHS 3) compliant.
2. See <https://www.diodes.com/quality/lead-free/> for more information about Diodes Incorporated’s definitions of Halogen- and Antimony-free, “Green” and Lead-free.
3. Halogen- and Antimony-free “Green” products are defined as those which contain <900ppm bromine, <900ppm chlorine (<1500ppm total Br + Cl) and <1000ppm antimony compounds.

Pin Configuration

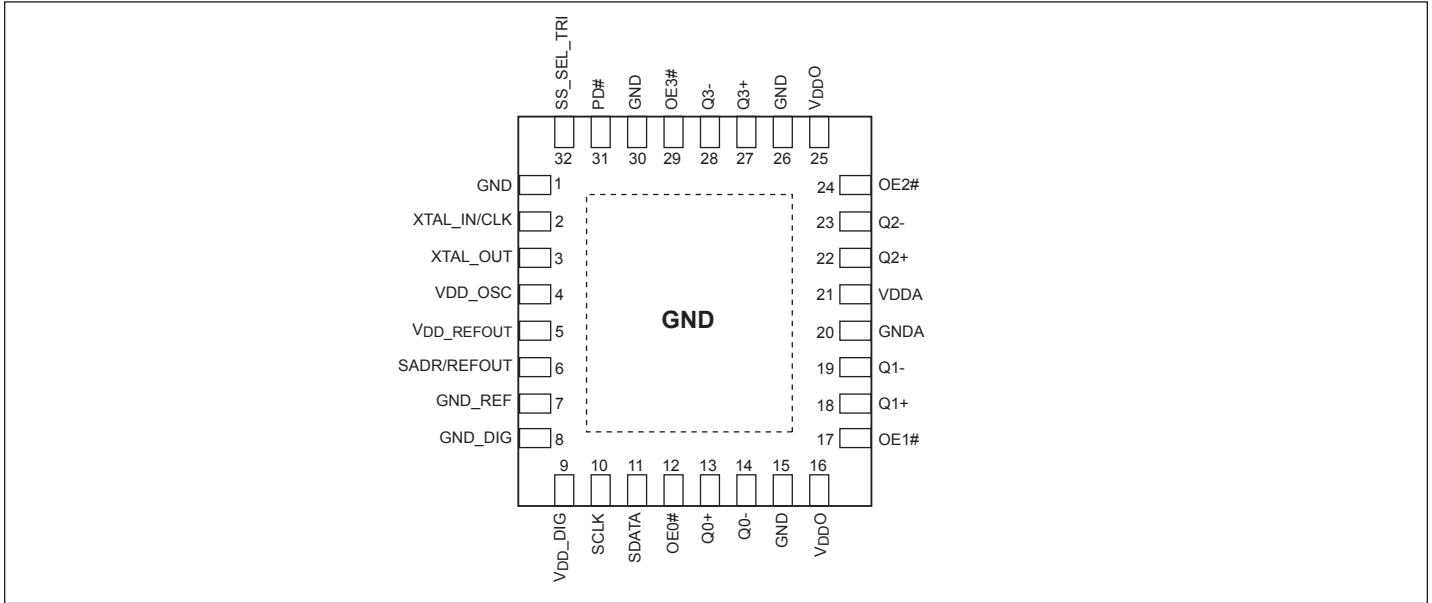

Pin Description

Pin #	Pin Name	Type		Description
1, 15, 26, 30	GND	Power		Ground pin
2	XTAL_IN/CLK	Input		Crystal input or CMOS reference input
3	XTAL_OUT	Output		Crystal output
4	V _{DD} _OSC	Power		Power supply for oscillator circuitry, nominal 3.3V
5	V _{DD} _REFOUT	Power		Power supply for buffered CMOS output
6	SADR/REFOUT	Input/ Output	CMOS	Latch to select SMBus Address or LVCMOS REFOUT. This pin has an internal pulldown.
7	GND_REF	Power		Ground for REFOUT
8	GND_DIG	Power		Ground for digital circuitry
9	V _{DD} _DIG	Power		Power supply for digital circuitry, nominal 3.3V
10	SCLK	Input	CMOS	SMBUS clock input, 3.3V tolerant
11	SDATA	Input/ Output	CMOS	SMBUS Data line, 3.3V tolerant
12	OE0#	Input	CMOS	Active low input for enabling Q0 pair. This pin has an internal pull-down. 1 =disable outputs, 0 = enable outputs
13	Q0+	Output	HCSL	Differential true clock output
14	Q0-	Output	HCSL	Differential complementary clock output
16, 25	V _{DDO}	Power		Power supply for differential outputs

Pin #	Pin Name	Type		Description
17	OE1#	Input	CMOS	Active low input for enabling Q1 pair. This pin has an internal pull-down. 1 =disable outputs, 0 = enable outputs
18	Q1+	Output	HCSL	Differential true clock output
19	Q1-	Output	HCSL	Differential complementary clock output
20	GNDA	Power		Ground for analog circuitry
21	V _{DDA}	Power		Power supply for analog circuitry
22	Q2+	Output	HCSL	Differential true clock output
23	Q2-	Output	HCSL	Differential complementary clock output
24	OE2#	Input	CMOS	Active low input for enabling Q2 pair. This pin has an internal pull-down. 1 =disable outputs, 0 = enable outputs
27	Q3+	Output	HCSL	Differential true clock output
28	Q3-	Output	HCSL	Differential complementary clock output
29	OE3#	Input	CMOS	Active low input for enabling Q3 pair. This pin has an internal pull-down. 1 =disable outputs, 0 = enable outputs
31	PD#	Input	CMOS	Input notifies device to sample latched inputs and start up on first high assertion. Low enters Power Down Mode, subsequent high assertions exit Power Down Mode. This pin has internal pullup resistor.
32	SS_SEL_TRI	Input	Tri-level	Latched select input to select spread-spectrum amount at initial power up. 1 = 0.5% spread, M = Spread off, 0 = Spread off. This pin has both internal pull-up and pull-down. Refer to SMBUS byte_1 bit 4, 3 = '01' to get -0.25% spread.
Epad	GND	Power		Connect to ground

Table 1. SMBus Address Selection

	SADR	Address	+Read/Write Bit
State of SADR on First Application of PD#	0	1101000	X
	1	1101010	X

Table 2. Power Management⁽³⁾

PD#	SMBus OE bit	OEn#	Qn+	Qn-	REFOUT
0	X	X	Low ⁽¹⁾	Low ⁽¹⁾	HiZ ⁽²⁾
1	1	0	Running	Running	Running
1	1	1	Disabled ⁽¹⁾	Disabled ⁽¹⁾	Running
1	0	X	Disabled ⁽¹⁾	Disabled ⁽¹⁾	Disabled ⁽⁴⁾

Note:

1. The output state is set by B11[1:0] (Low/Low default).
2. REF is Hi-Z until the 1st assertion of PD# high. After this, when PD# is low, REF is disabled. If Byte3, bit 5 = 1, then REF is running.
3. Input High/ Low defined at default values for device.
4. See SMBUs Byte 3, bit 4 .

Maximum Ratings

(Above which useful life may be impaired. For user guidelines, not tested.)

Storage Temperature.....	-65°C to +150°C
Supply Voltage to Ground Potential, V_{DDXX}	-0.5V to +4.6V
Input Voltage	-0.5V to $V_{DD}+0.5V$, not exceed 4.6V
SMBus, Input High Voltage	3.6V
ESD Protection (HBM)	2000V
Max Junction Temperature	+125°C

Note:

Stresses greater than those listed under MAXIMUM RATINGS may cause permanent damage to the device. This is a stress rating only and functional operation of the device at these or any other conditions above those indicated in the operational sections of this specification is not implied. Exposure to absolute maximum rating conditions for extended periods may affect reliability.

Operating Conditions

Temperature = T_A ; Supply voltages per normal operation conditions; See test circuits for the load conditions

Symbol	Parameters	Conditions	Min.	Typ.	Max.	Units
$V_{DDO}, V_{DDA}, V_{DD_OSC}, V_{DD_DIG}, V_{DD_RE-FOUT}$	Power Supply Voltage		3.135	3.3	3.465	V
I_{DDA}	Analog Power Supply Current	All outputs active @ 100MHz		22	25	mA
I_{DD}	Power Supply Current	All V_{DD} , except V_{DDA} and V_{DDO} , All outputs active @ 100MHz		13	16	mA
I_{DDO}	IO Power Supply Current ⁽³⁾	V_{DDO} , All outputs active @ 100MHz		20	25	mA
I_{DDA_WL}	Analog Power Supply Wake-on-LAN ⁽¹⁾ Current	Q outputs off, REF output running		0.5	1	mA
I_{DD_WL}	Power Supply Wake-on-LAN ⁽¹⁾ Current	All V_{DD} , except V_{DDA} and V_{DDO} , Q outputs off, REF output running		3	6	mA
I_{DDO_WL}	Power Supply Wake-on-LAN ⁽¹⁾ Current for Outputs	Q outputs off, REF output running		1	2	mA
I_{DDA_PD}	Analog Power Supply Power Down ⁽²⁾ Current	All outputs off		0.5	1	mA
I_{DDO_PD}	IO Power Down ⁽²⁾ Current	All outputs off		1	2	mA
I_{DD_PD}	Power Supply Power Down ⁽²⁾ Current	All outputs off		1	2	mA
T_A	Ambient Temperature	Industrial grade	-40		85	°C

Note:

1. Wake-on-LAN mode: PD# = '0' Byte 3, bit 5 = '1'.
2. Power down mode: PD# = '0' Byte 3, bit 5 = '0'.
3. Outputs drive 5 inch trace.

Input Electrical Characteristics

Symbol	Parameters	Conditions	Min.	Typ.	Max.	Units
R _{pu}	Internal Pullup Resistance			120		KΩ
R _{dn}	Internal Pulldown Resistance			120		KΩ
C _{XTAL}	Internal Capacitance on X_IN and X_OUT pins			8		pF
L _{PIN}	Pin Inductance				7	nH

Crystal Characteristic

Parameters	Description	Min.	Typ	Max.	Units
OSCmode	Mode of Oscillation	Fundamental			
FREQ	Frequency		25		MHz
ESR ⁽¹⁾	Equivalent Series Resistance			50	Ω
Cload	Load Capacitance		8		pF
Cshunt	Shunt Capacitance			7	pF
—	Drive Level			200	μW

Note:

- ESR value is dependent upon frequency of oscillation.

SMBus Electrical Characteristics

Temperature = T_A; Supply voltages per normal operation conditions; See test circuits for the load conditions.

Symbol	Parameters	Conditions	Min.	Typ.	Max.	Units
V _{DDSMB}	Nominal Bus Voltage		2.7		3.6	V
V _{IHSMB}	SMBus Input High Voltage	SMBus, V _{DDSMB} = 3.3V	2.1		3.6	V
		SMBus, V _{DDSMB} < 3.3V	0.65 V _{DDSMB}			
V _{ILSMB}	SMBus Input Low Voltage	SMBus, V _{DDSMB} = 3.3V			0.8	V
		SMBus, V _{DDSMB} < 3.3V			0.8	
I _{SMBSINK}	SMBus Sink Current	SMBus, at V _{OLSMB}	4			mA
V _{OLSMB}	SMBus Output Low Voltage	SMBus, at I _{SMBSINK}			0.4	V
f _{MAXSMB}	SMBus Operating Frequency	Maximum frequency			500	kHz
t _{RMSB}	SMBus Rise Time	(Max V _{IL} - 0.15) to (Min V _{IH} + 0.15)			1000	ns
t _{FMSB}	SMBus Fall Time	(Min V _{IH} + 0.15) to (Max V _{IL} - 0.15)			300	ns

Spread Spectrum Characteristic

Temperature = T_A ; Supply voltages per normal operation conditions; See test circuits for the load conditions.

Symbol	Parameters	Conditions	Min.	Typ.	Max.	Units
f_{MOD}	SS Modulation Frequency	Triangular modulation	30	31.8	33	kHz

LVC MOS DC Electrical Characteristics

Temperature = T_A ; Supply voltages per normal operation conditions; See test circuits for the load conditions

Symbol	Parameters	Conditions	Min.	Typ.	Max.	Units
V_{IH}	Input High Voltage	Single-ended inputs, except SMBus	0.75 V_{DD}		V_{DD} +0.3	V
V_{IM}	Input Mid Voltage	SS_SEL_TRI	$0.4V_{DD}$	$0.5V_{DD}$	$0.6V_{DD}$	V
V_{IL}	Input Low Voltage	Single-ended inputs, except SMBus	-0.3		0.25 V_{DD}	V
I_{IH}	Input High Current	Single-ended inputs, $V_{IN} = V_{DD}$			5	μA
I_{IL}	Input Low Current	Single-ended inputs, $V_{IN} = 0V$	-5			μA
I_{IH}	Input High Current	Single-ended inputs with pullup/ pulldown resistor, $V_{IN} = V_{DD}$			50	μA
I_{IL}	Input Low Current	Single-ended inputs with pullup/ pulldown resistor, $V_{IN} = 0V$	-50			μA
V_{OH}	Output High Voltage	REFOUT, except SMBus; $I_{OH} = -2mA$	$0.8 \times$ $V_{DD_}$ REFOUT			V
V_{OL}	Output Low Voltage	REFOUT, except SMBus; $I_{OL} = 2mA$			$0.2 \times$ $V_{DD_}$ REFOUT	V
R_{OUT}	CMOS Output Impedance			20		Ω
C_{IN}	Input Capacitance		1.5		5	pF

LVC MOS AC Characteristics

Temperature = T_A ; Supply voltages per normal operation conditions; See test circuits for the load conditions

Symbol	Parameters	Conditions	Min.	Typ.	Max.	Units
f_{INPUT}	Input Frequency	XTAL_IN/CLK		25		MHz
t_{RIN}	Input Rise Time	Single-ended inputs			5	ns
t_{FIN}	Input Fall Time	Single-ended inputs			5	ns
t_{STAB}	Clock Stabilization	From power up and after input clock stabilization or deassertion of PD# to first clock		0.75	1	ms
t_{OELAT}	Output Enable Latency	Q start after OE# assertion Q stop after OE# deassertion	1		3	clocks

Symbol	Parameters	Conditions	Min.	Typ.	Max.	Units
t _{PDLAT}	PD# Deassertion	Differential outputs enable after PD# deassertion		20	300	μs
t _{PERIOD}	REFOUT Clock Period	REFOUT, assume input is at 25MHz		40		ns
f _{ACC}	REFOUT Frequency Accuracy ⁽¹⁾	REFOUT, long term accuracy to input		0		ppm
t _{SLEW}	REFOUT Slew Rate ⁽¹⁾	Byte 3 = 1F, 20% to 80% of V _{D-DREF}	0.9	1.4	2	V/ns
		Byte 3 = 5F, 20% to 80% of V _{D-DREF}	1.5	2.4	3.2	V/ns
		Byte 3 = 9F, 20% to 80% of V _{D-DREF}	2.0	3.0	3.8	V/ns
		Byte 3 = DF, 20% to 80% of V _{D-DREF}	2.3	3.2	4	V/ns
t _{DC}	REFOUT Duty Cycle ⁽¹⁾	V _T = V _{DD} / 2V, driven by a Xtal	45	50	55	%
t _{DCDIS}	REFOUT Duty Cycle Distortion	V _T = V _{DD} / 2V, driven by an external source	-2	0	+2	%
t _{JITCC}	REFOUT Cycle-Cycle Jitter	V _T = V _{DD} / 2V, driven by a Xtal		70	150	ps
t _{JITPH}	REFOUT Phase Jitter, RMS	12kHz to 5MHz, SSC off, driven by a Xtal		0.16	0.3	ps
		12kHz to 5MHz, SSC on, driven by a Xtal		0.9	1.5	ps
t _{JITN}	Noise Floor	1kHz offset, driven by a Xtal		-149	-135	dBc/Hz
		10kHz offset to Nyquist, driven by a Xtal		-158	-140	dBc/Hz

Note:

1. Guaranteed by design and characterization—not 100% tested in production.

HCSL Output Characteristics

Temperature = T_A ; Supply voltages per normal operation conditions; See test circuits for the load conditions

Symbol	Parameters	Condition	Min.	Typ.	Max.	Units
V_{OH}	Output Voltage High ⁽¹⁾	Statistical measurement on single-ended signal using oscilloscope math function	660	784	850	mV
V_{OL}	Output Voltage Low ⁽¹⁾		-150		150	mV
V_{OMAX}	Output Voltage Maximum ⁽¹⁾	Measurement on single ended signal using absolute value		816	1150	mV
V_{OMIN}	Output Voltage Minimum ⁽¹⁾		-300	-42		mV
V_{OC}	Output Cross Voltage ^(1,2,4)		250	430	550	mV
DV_{OC}	V_{OC} Magnitude Change ^(1,2,5)			12	140	mV

Note:

- At default SMBUS amplitude settings.
- Guaranteed by design and characterization—not 100% tested in production.
- Measured from differential waveform.
- This one is defined as voltage where $Q+ = Q-$ measured on a component test board and only applied to the differential rising edge.
- The total variation of all V_{cross} measurements in any particular system. This is a subset of $V_{cross_min/max}$ allowed.

HCSL Output AC Characteristics

Temperature = T_A ; Supply voltages per normal operation conditions; See test circuits for the load conditions.

Symbol	Parameters	Condition	Min.	Typ.	Max.	Units
f_{OUT}	Output Frequency			100		MHz
t_{RF}	Slew Rate ^(1,2,3)	Scope averaging on fast setting	2.5	3.2	4	V/ns
		Scope averaging on slow setting	2.2	3	3.7	V/ns
D_{tRF}	Slew Rate Matching ^(1,2,4)	Scope averaging on		7	15	%
t_{DC}	Duty Cycle ^(1,2)	Measured differentially, PLL Mode	45	50	55	%
t_{SKEW}	Output Skew ^(1,2)	Averaging on, $V_T = 50\%$		20	50	ps
t_{jC-C}	Cycle-to-Cycle Jitter ^(1,2)			20	50	ps

Note:

- Guaranteed by design and characterization—not 100% tested in production.
- Measured from differential waveform.
- Slew rate is measured through the V_{swing} voltage range centered around differential 0V, within $\pm 150mV$ window.
- It is measured using a $\pm 75mV$ window centered on the average cross point.

PCIe Common Clock (CC) Architecture Jitter

Symbol	Parameters	Condition	Min.	Typ.	Max.	Spec Limit	Units
t _{JPHASE}	Integrated phase jitter (RMS)	PCIe 1.0		20	30	86	ps (pkpk)
		PCIe 2.0 Low Band, 10kHz < f < 1.5MHz (PLL BW 5-16MHz or 8-5MHz, CDR = 10MHz)		0.1	0.2	3	ps
		PCIe 2.0 High Band, 1.5MHz < f < Nyquist (50MHz); (PLL BW 5-16MHz or 8-5MHz, CDR = 10MHz)		0.4	0.5	3.1	ps
		PCIe 3.0 (PLL BW 2-4MHz or 2-5MHz, CDR = 10MHz)		0.15	0.2	1	ps
		PCIe 4.0 (PLL BW 2-4MHz or 2-5MHz, CDR = 10MHz)		0.15	0.2	0.5	ps
		PCIe 5.0		0.05	0.06	0.15	ps
		PCIe 6.0		0.03	0.04	0.1	ps

PCIe Independent Reference Clock Architecture Jitter

Symbol	Parameters	Condition	Min.	Typ.	Max.	Spec Limit	Units
t _{JPHASE}	Integrated phase jitter (RMS)	PCIe 3.0 SRIS (PLL BW 2-4MHz or 2-5MHz, CDR = 10MHz)		0.15	0.25		ps
		PCIe 4.0 SRIS (PLL BW 2-4MHz or 2-5MHz, CDR = 10MHz)		0.15	0.25		ps
		PCIe 5.0 SRIS		0.04	0.07		ps
		PCIe 6.0 SRIS		0.03	0.05		ps

PI6CG33401C

Differential Output Clock Periods - Spread Spectrum Disabled

Center Freq. MHz	Measurement Window							Units
	1 clock	1 μ s	0.1 s	0.1 s	0.1 s	1 μ s	1 clock	
	-c2c jitter AbsPer Min	-SSC Short-term Avg. Min	-ppm Long-term Avg. min	0 ppm Period Nominal	+ppm Long-term Avg. max	+SSC Short-term Avg. Max	-c2c jitter AbsPer Max	
100.00	9.94900		9.99900	10.00000	10.00100		10.05100	ns

Differential Output Clock Periods - Spread Spectrum Enabled

Center Freq. MHz	Measurement Window							Units
	1 clock	1 μ s	0.1 s	0.1 s	0.1 s	1 μ s	1 clock	
	-c2c jitter AbsPer Min	-SSC Short-term Avg. Min	-ppm Long-term Avg. min	0 ppm Period Nominal	+ppm Long-term Avg. max	+SSC Short-term Avg. Max	-c2c jitter AbsPer Max	
99.75	9.94906	9.99906	10.02406	10.02506	10.02607	10.05107	10.10107	ns

Note:

1. Guaranteed by design and characterization—not 100% tested in production.
2. All long term accuracy and clock period specifications are guaranteed assuming REF is trimmed to 25.00MHz.

SMBus Serial Data Interface

PI6CG33401C is a slave-only device that supports block read and block write protocol using a single 7-bit address and read/write bit as shown below.

Read and write block transfers can be stopped after any complete byte transfer.

Address Assignment

A6	A5	A4	A3	A2	A1	A0	R/W
1	1	0	1	0	SADR	0	1/0

Note:

1. SMBus address is latched on SADR pin.

How to Write

1 bit	7 bits	1 bit	1 bit	8 bits	1 bit	8 bits	1 bit	8 bits	1 bit		8 bits	1 bit	1 bit
Start bit	Add.	W(0)	Ack	Beginning Byte location = N	Ack	Data Byte count = X	Ack	Beginning Data Byte (N)	Ack	Data Byte (N+X-1)	Ack	Stop bit

How to Read

1 bit	7 bits	1 bit	1 bit	8 bits	1 bit	1 bit	7 bits	1 bit	1 bit	8 bits	1 bit	8 bits	1 bit
Start bit	Address	W(0)	Ack	Beginning Byte location = N	Ack	Repeat Start bit	Address	R(1)	Ack	Data Byte count = X	Ack	Beginning Data Byte (N)	Ack

	8 bits	1 bit	1 bit
.....	Data Byte (N+X-1)	NAck	Stop bit

Byte 0: Output Enable Register

Bit	Control Function	Description	Type	Power-up Condition	0	1
7	Reserved			0	See B11[1:0]	
6	Reserved			0		
5	Reserved			0		
4	Reserved			0		
3	Q3_OE	Q3 output enable	RW	1		Pin Control
2	Q2_OE	Q2 output enable	RW	1		Pin Control
1	Q1_OE	Q1 output enable	RW	1		Pin Control
0	Q0_OE	Q0 output enable	RW	1		Pin Control

Note:

1. A low on these bits will override the OE# pins and force the differential outputs to the state indicated by B11[1:0] (Low/ Low default).

Byte 1: SS Spread Spectrum and Control Register						
Bit	Control Function	Description	Type	Power-up Condition	0	1
7	SSENRB1	SS Enable Readback Bit1	R	Latch	'00' for SS_SEL_TRI = '0', '10' for SS_SEL_TRI = 'M', '11' for SS_SEL_TRI = '1'	
6	SSENRB0	SS Enable Readback Bit0	R	Latch		
5	SSEN_SWCTR	Enable SW control of SS	RW	0	Values in B1[7:6] control SS amount	Values in B1[4:3] control SS amount
4	SSENSW1	SS enable SW control Bit1	RW ⁽¹⁾	0	'00' = SS off, '01' = -0.25% SS, '10' = SS off, '11' = -0.5% SS	
3	SSENSW0	SS enable SW control Bit0	RW ⁽¹⁾	0		
2	Reserved			1		
1	Amplitude1	Control output amplitude	RW	1	'00' = 0.6V, '01' = 0.68V, '10' = 0.75V, '11' = 0.85V	
0	Amplitude0		RW	0		

Note:

1. Spread must be selected OFF or ON with the hardware latch pin. These bits must not be used to turn spread ON or OFF after power up. These bits can be used to change the spread amount, and B1[5] must be set to a 1 for these bits to have any effect on the part. If these bits are used to turn spread OFF or ON, the system must be reset.

Byte 2: Differential Output Slew Rate Control Register						
Bit	Control Function	Description	Type	Power-up Condition	0	1
7	Reserved			1		
6	Reserved			1		
5	Reserved			1		
4	Reserved			1		
3	SLEWRATECTR_Q3	Control slew rate of Q3	RW	1	Slow setting	Fast setting
2	SLEWRATECTR_Q2	Control slew rate of Q2	RW	1	Slow setting	Fast setting
1	SLEWRATECTR_Q1	Control slew rate of Q1	RW	1	Slow setting	Fast setting
0	SLEWRATECTR_Q0	Control slew rate of Q0	RW	1	Slow setting	Fast setting

Byte 3: REF Control Register						
Bit	Control Function	Description	Type	Power-up Condition	0	1
7	REFSLEWRATE	Slew rate control for REF	RW	0	'00' = 1.4V/ns '01' = 2.4V/ns, '10' = 3V/ns, '11' = 3.2V/ns	
6			RW	1		
5	REF_PDSTATE	Wake-on-Lan enable for REF	RW	0	REF = Disabled in PD state ⁽¹⁾	REF = running in PD state
4	REF_OE	Output enable for REF	RW	1	REF = Disabled ⁽¹⁾	REF = running
3	Reserved			1		
2	Reserved			1		
1	Reserved			1		
0	Reserved			1		

Note:

- The disabled state depends on Byte11[1:0]. '00' = Low, '01'=HiZ, '10'=Low, '11'=High.

Byte 4: Reserved						
Bit	Control Function	Description	Type	Power-up Condition	0	1
7:0	Reserved			0x40		

Byte 5: Revision and Vendor ID Register						
Bit	Control Function	Description	Type	Power-up Condition	0	1
7	RID3	Revision ID	R	0	Rev = 0000	
6	RID2		R	0		
5	RID1		R	0		
4	RID0		R	0		
3	PVID3	Vendor ID	R	0	Diodes = 0011	
2	PVID2		R	0		
1	PVID1		R	1		
0	PVID0		R	1		

Byte 6: Device Type/Device ID Register						
Bit	Control Function	Description	Type	Power-up Condition	0	1
7	DTYPE1	Device type	R	0	'00' = CG, '01' = ZDB, '10' = Reserved, '11' = NZDB	
6	DTYPE0		R	0		
5	DID5	Device ID	R	0	000100 binary, 04Hex	
4	DID4		R	0		
3	DID3		R	0		
2	DID2		R	1		
1	DID1		R	0		
0	DID0		R	0		
Byte 7: Byte Count Register						
Bit	Control Function	Description	Type	Power-up Condition	0	1
7	Reserved			0		
6	Reserved			0		
5	Reserved			0		
4	BC4	Byte count programming	RW	0	Writing to this register will configure how many bytes will be read back, default is 8 bytes	
3	BC3		RW	1		
2	BC2		RW	0		
1	BC1		RW	0		
0	BC0		RW	0		
Byte 8 and 9: Reserved						
Bit	Control Function	Description	Type	Power-up Condition	0	1
7:0	Reserved			B8: 0x36 B9: 0x00		
Byte 10: PD Restore						
Bit	Control Function	Description	Type	Power-up Condition	0	1
7	Reserved			0		
6	PD Restore	PD Restore to default configuration	RW	1	Clear PD Config	Keep PD Config
5:0	Reserved			0		

Byte 11: Stop Control						
Bit	Control Function	Description	Type	Power-up Condition	0	1
7:2	Reserved			0		
1	STP1	True/ Compliment DIF Output Disable Sate	RW	0	00 = Low/Low	10 = High/Low
0	STP0		RW	0	01 = HiZ/HiZ	11 = Low/High

Byte 12: Impedance Control						
Bit	Control Function	Description	Type	Power-up Condition	0	1
7	Q1_Zout1	Q1 Zout	RW	10	00 = Reserved 01 = 85Ω 10 = 100Ω 11 = Reserved	
6	Q1_Zout0	Q1 Zout	RW			
5	Reserved					
4	Reserved					
3	Q0_Zout1	Q0 Zout	RW			
2	Q0_Zout0	Q0 Zout	RW			
1	Reserved					
0	Reserved					

Byte 13: Impedance Control						
Bit	Control Function	Description	Type	Power Up Condition	0	1
7	Reserved			10	00 = Reserved 01 = 85Ω 10 = 100Ω 11 = Reserved	
6	Reserved					
5	Q3_Zout1	Q3 Zout	RW			
4	Q3_Zout0	Q3 Zout	RW			
3	Q2_Zout1	Q2 Zout	RW			
2	Q2_Zout0	Q2 Zout	RW			
1	Reserved					
0	Reserved					

Byte 14: OE Termination Control						
Bit	Control Function	Description	Type	Power-up Condition	0	1
7	OE1_term1	OE1 pullup or down	RW	0	00 = None	10 = Pullup
6	OE1_term0	OE1 pullup or down	RW	1	01 = Pull-down	11 = Pullup and Down
5	Reserved			0		
4	Reserved			1		
3	OE0_term1	OE0 pullup or down	RW	0	00 = None	10 = Pullup
2	OE0_term0	OE0 pullup or down	RW	1	01 = Pull-down	11 = Pullup and Down
1	Reserved			0		
0	Reserved			1		

Byte 15: OE Termination Control						
Bit	Control Function	Description	Type	Power-up Condition	0	1
7	Reserved			0		
6	Reserved			1		
5	OE3_term1	OE3 pullup or down	RW	0	00 = None	10 = Pullup
4	OE3_term0	OE3 pullup or down	RW	1	01 = Pull-down	11 = Pullup and Down
3	OE2_term1	OE2 pullup or down	RW	0	00 = None	10 = Pullup
2	OE2_term0	OE2 pullup or down	RW	1	01 = Pull-down	11 = Pullup and Down
1	Reserved			0		
0	Reserved			1		

Byte 16: Power Good Termination Control						
Bit	Control Function	Description	Type	Power-up Condition	0	1
7:2	Reserved			0x09		
1	PWRGD_PD1	Clock power good and power-down pullup or pulldown	RW	1	00 = None	10 = Pullup
0	PWRGD_PD0		RW	0	01 = Pull-down	11 = Pullup and Down

Byte 17: Reserved						
--------------------------	--	--	--	--	--	--

Byte 18: Enable Pin Control						
Bit	Control Function	Description	Type	Power-up Condition	0	1
7	Reserved			0		
6	OE3_Enable	Sets Enable High or Low	RW	0	Enable = Low	Enable = High
5	OE2_Enable	Sets Enable High or Low	RW	0	Enable = Low	Enable = High
4	Reserved			0		
3	OE1_Enable	Sets Enable High or Low	RW	0	Enable = Low	Enable = High
2	Reserved			0		
1	OE0_Enable	Sets Enable High or Low	RW	0	Enable = Low	Enable = High
0	Reserved			0		

Byte 19: Power Down Pin Control						
Bit	Control Function	Description	Type	Power-up Condition	0	1
7:1	Reserved			0		
0	PWRGD_PD	PWRGD_PD Active via Pullup or Pulldown	RW	0	Power Down = Low	Power Down = High

Phase Noise Plots

100MHz HCSL Clock (12k to 20MHz)

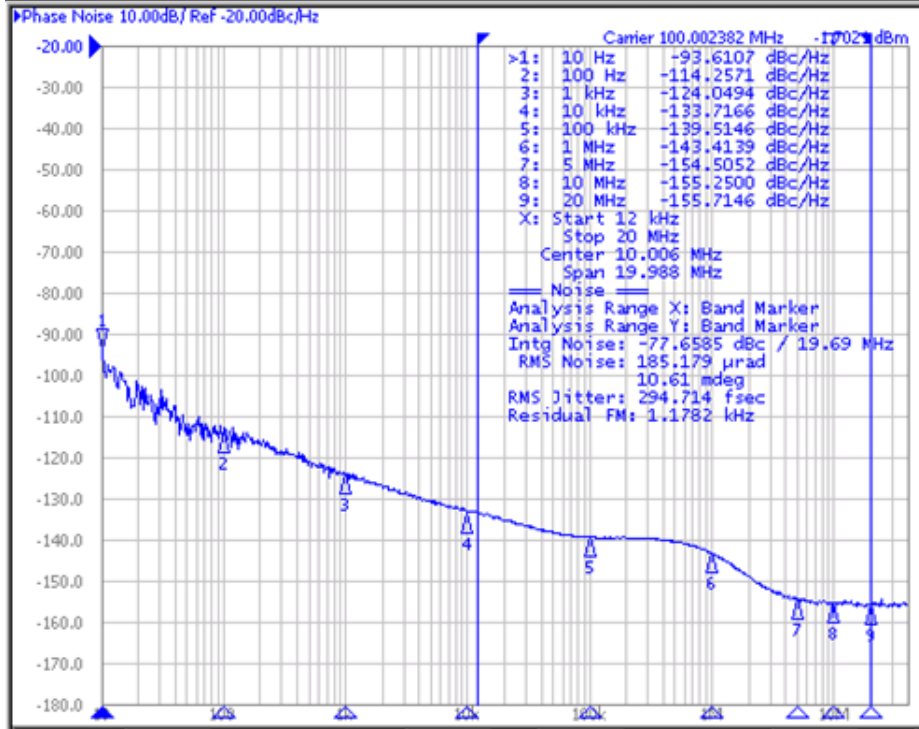

25MHz CMOS Clock

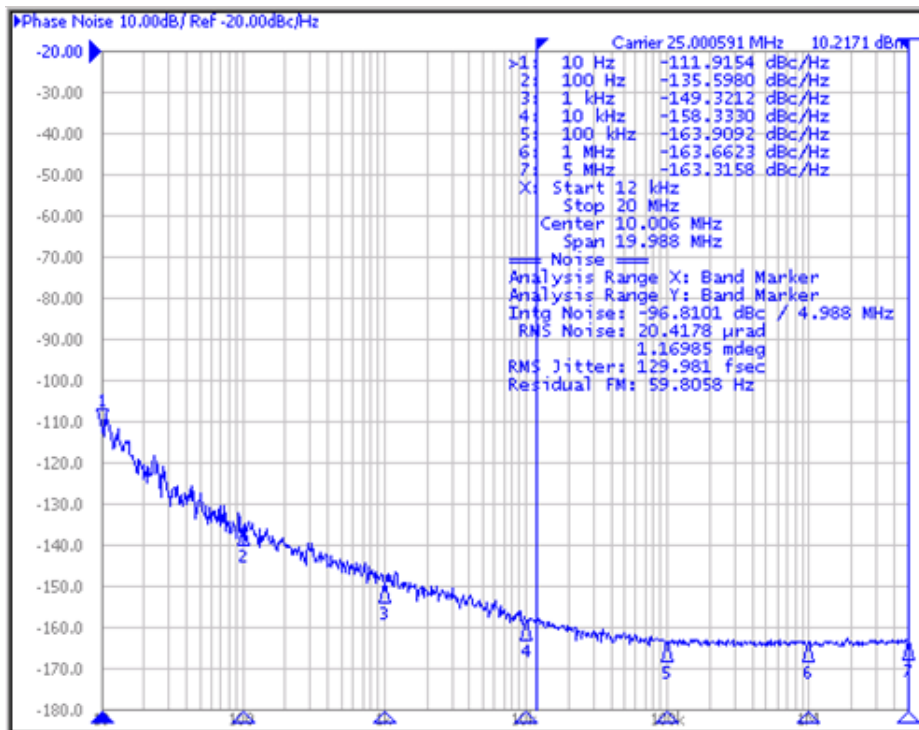

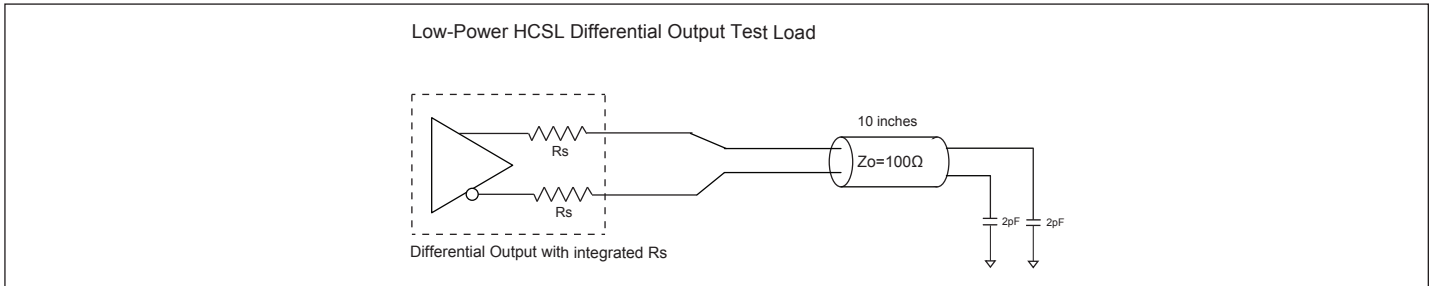

Figure 1. Low Power HCSL Test Circuit

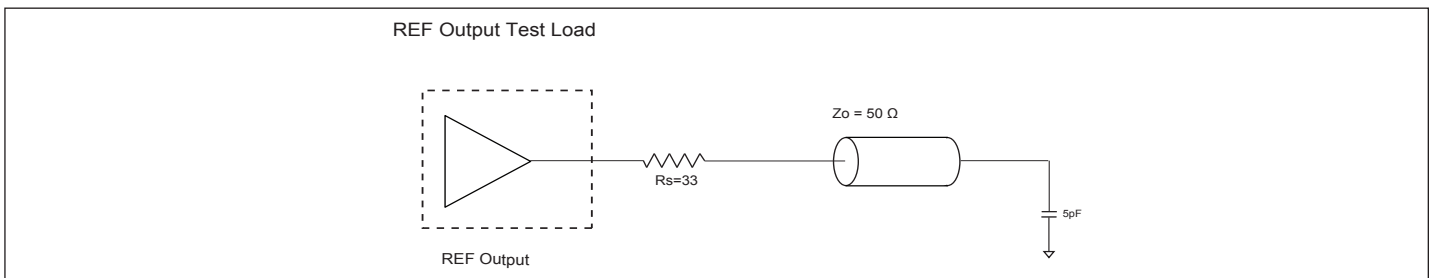

Figure 2. CMOS REF Test Circuit

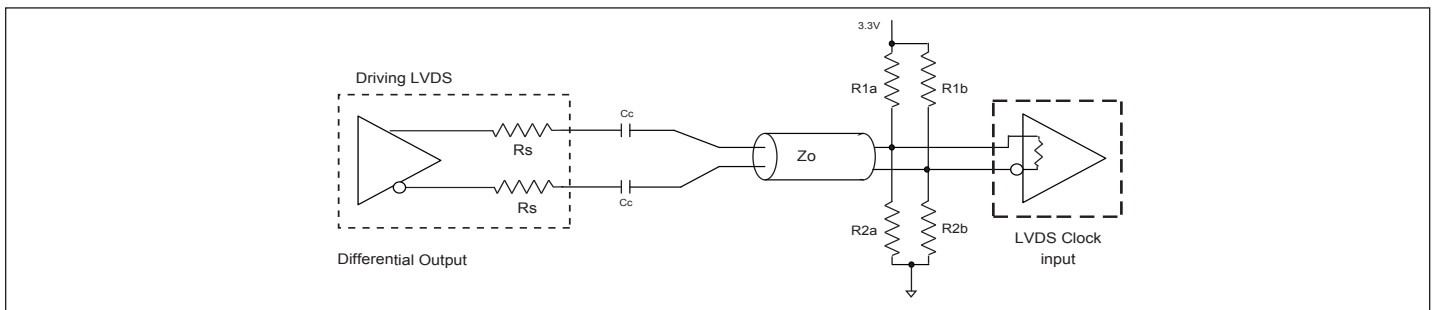

Figure 3. Differential Output Driving LVDS

Table 3. Alternate Differential Output Terminations

Component	Receiver with Termination	Receiver without Termination	Unit
R _{1a} , R _{1b}	10,000	140	Ω
R _{2a} , R _{2b}	5600	75	Ω
C _C	0.1	0.1	μF
V _{CM}	1.2	1.2	V

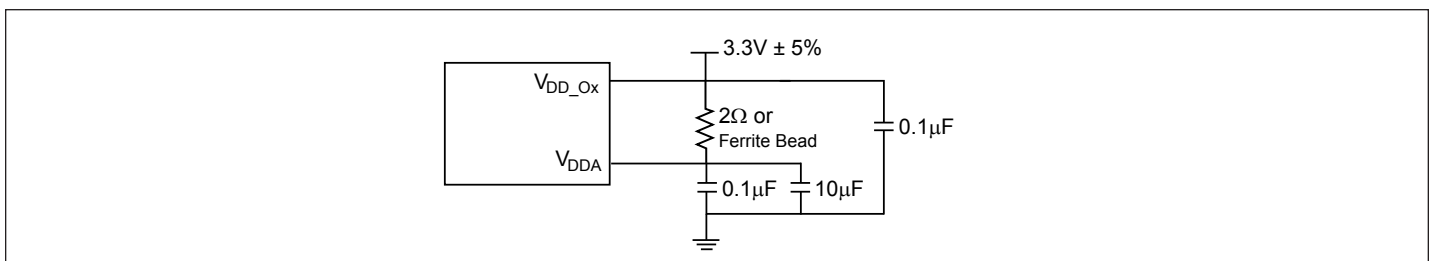
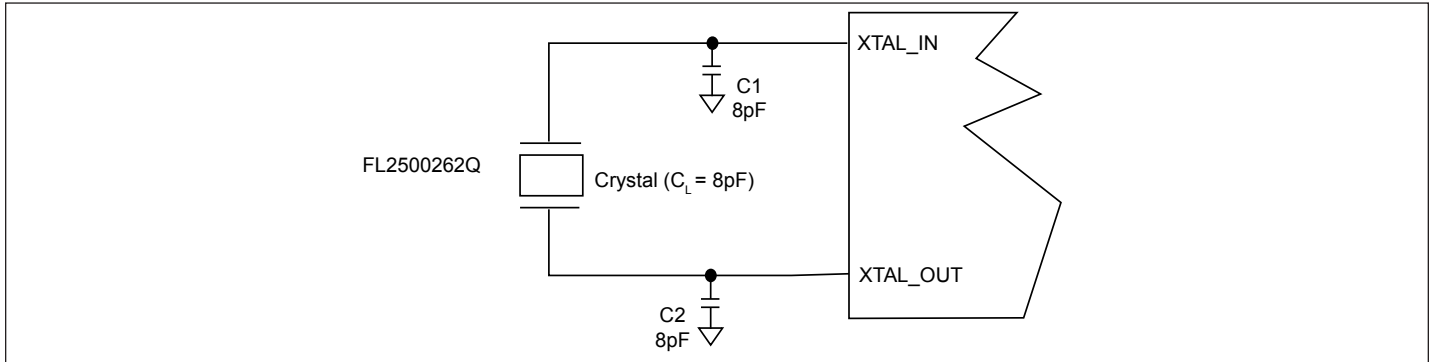

Figure 4. Power Supply Filter

Crystal Circuit Connection

The following diagram shows PI6CG33401C crystal circuit connection with a parallel crystal. For the $CL = 8\text{pF}$ crystal, it is suggested to use $C1 = 8\text{pF}$ and $C2 = 8\text{pF}$. $C1$ and $C2$ can be adjusted to fine tune to the target ppm of crystal oscillator according to different board layouts based on the following formula in the Crystal Capacitor Calculation diagram.

Crystal Oscillator Circuit



Crystal Capacitor Calculation

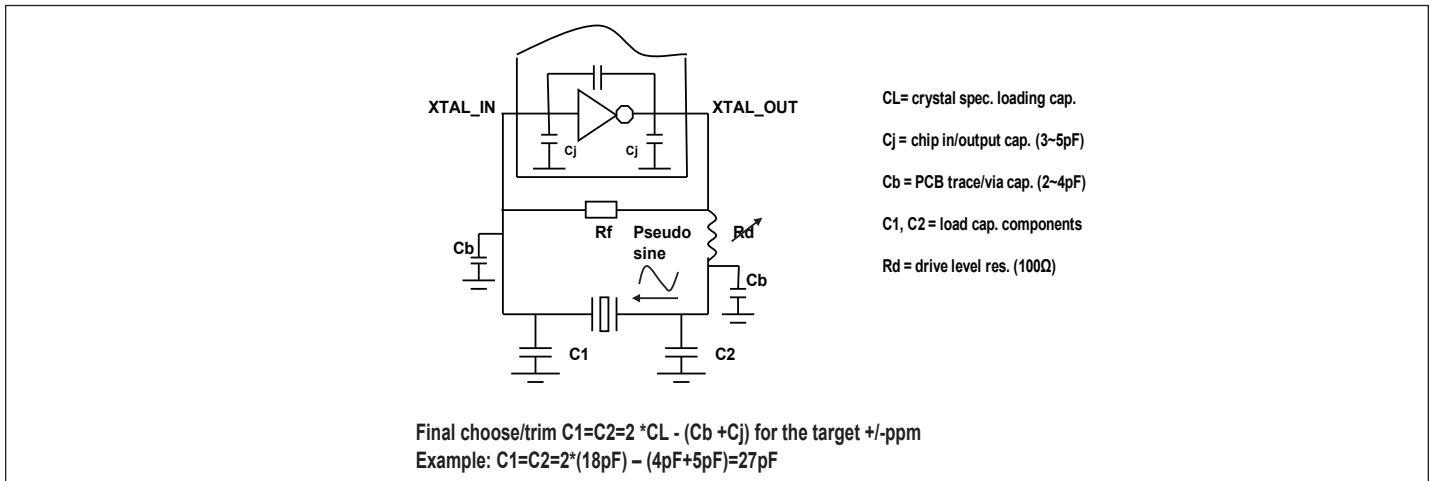

Recommended Crystal Specification

Diodes Recommends:

- FL2500217, SMD 3.2x2.5(4P), 25MHz, $CL=8\text{pF}$, +/-20ppm, <https://www.diodes.com/assets/Datasheets/FL.pdf>
- FH2500016, SMD 2.5x2.0(4P), 25MHz, $CL=8\text{pF}$, +/-30ppm, <https://www.diodes.com/assets/Datasheets/FH.pdf>
- FW2500031, SMD 2.0x1.6(4P), 25MHz, $CL=8\text{pF}$, +/-30ppm, <https://www.diodes.com/assets/Datasheets/FW.pdf>
- US2500003, SMD 1.6x1.2(4P), 25MHz, $CL=12\text{pF}$, +/-30ppm, <https://www.diodes.com/assets/Datasheets/US.pdf>

Table 4. Thermal Characteristics

Symbol	Parameter	Conditions	Min.	Typ.	Max.	Unit
θ_{JA}	Thermal Resistance Junction to Ambient	Still air			44.7	$^{\circ}\text{C}/\text{W}$
θ_{JC}	Thermal Resistance Junction to Case				21.7	$^{\circ}\text{C}/\text{W}$

PI6CG33401C

Part Marking

PI6CG33
401CZHIE
YYWWXX
○

YY: Year
WW: Workweek
1st X: Assembly Code
2nd X: Fab Code

Package Information

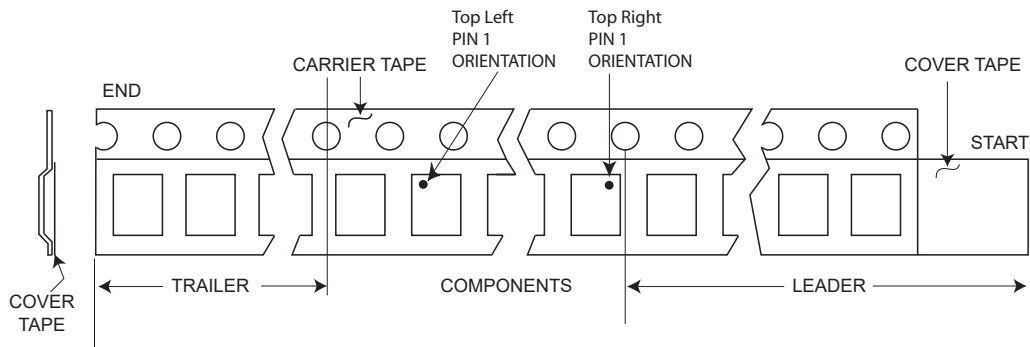

Packaging Mechanical

32-TQFN (ZH)

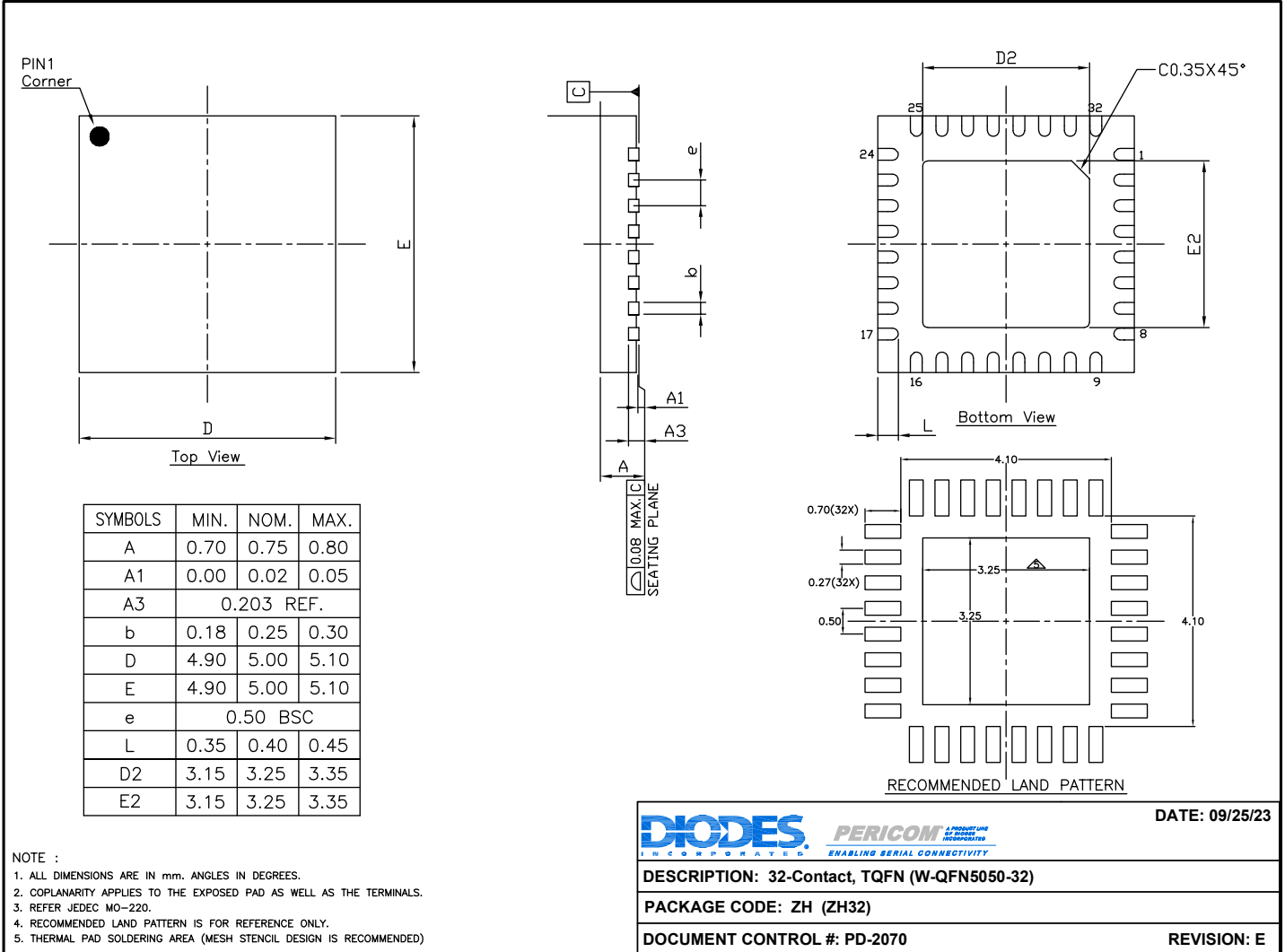

For latest package information:

See <http://www.diodes.com/design/support/packaging/pericom-packaging/packaging-mechanicals-and-thermal-characteristics/>.

Ordering Information

Ordering Code	Package Code	Package Description	Pin 1 Location
PI6CG33401CZHIEX	ZH	32-Contact, Thin Quad Flat No-Lead (TQFN)	Top Right Corner
PI6CG33401CZHIEX-13R	ZH	32-Contact, Thin Quad Flat No-Lead (TQFN)	Top Left Corner

Notes:

1. No purposely added lead. Fully EU Directive 2002/95/EC (RoHS), 2011/65/EU (RoHS 2) & 2015/863/EU (RoHS 3) compliant.
2. See <https://www.diodes.com/quality/lead-free/> for more information about Diodes Incorporated's definitions of Halogen- and Antimony-free, "Green" and Lead-free.
3. Halogen- and Antimony-free "Green" products are defined as those which contain <900ppm bromine, <900ppm chlorine (<1500ppm total Br + Cl) and <1000ppm antimony compounds.
4. E = Pb-free and Green
5. X suffix = Tape/Reel
6. For packaging details, go to our website at: <https://www.diodes.com/assets/MediaList-Attachments/Diodes-Package-Information.pdf>

IMPORTANT NOTICE

1. DIODES INCORPORATED (Diodes) AND ITS SUBSIDIARIES MAKE NO WARRANTY OF ANY KIND, EXPRESS OR IMPLIED, WITH REGARDS TO ANY INFORMATION CONTAINED IN THIS DOCUMENT, INCLUDING, BUT NOT LIMITED TO, THE IMPLIED WARRANTIES OF MERCHANTABILITY, FITNESS FOR A PARTICULAR PURPOSE OR NON-INFRINGEMENT OF THIRD PARTY INTELLECTUAL PROPERTY RIGHTS (AND THEIR EQUIVALENTS UNDER THE LAWS OF ANY JURISDICTION).
2. The Information contained herein is for informational purpose only and is provided only to illustrate the operation of Diodes' products described herein and application examples. Diodes does not assume any liability arising out of the application or use of this document or any product described herein. This document is intended for skilled and technically trained engineering customers and users who design with Diodes' products. Diodes' products may be used to facilitate safety-related applications; however, in all instances customers and users are responsible for (a) selecting the appropriate Diodes products for their applications, (b) evaluating the suitability of Diodes' products for their intended applications, (c) ensuring their applications, which incorporate Diodes' products, comply the applicable legal and regulatory requirements as well as safety and functional-safety related standards, and (d) ensuring they design with appropriate safeguards (including testing, validation, quality control techniques, redundancy, malfunction prevention, and appropriate treatment for aging degradation) to minimize the risks associated with their applications.
3. Diodes assumes no liability for any application-related information, support, assistance or feedback that may be provided by Diodes from time to time. Any customer or user of this document or products described herein will assume all risks and liabilities associated with such use, and will hold Diodes and all companies whose products are represented herein or on Diodes' websites, harmless against all damages and liabilities.
4. Products described herein may be covered by one or more United States, international or foreign patents and pending patent applications. Product names and markings noted herein may also be covered by one or more United States, international or foreign trademarks and trademark applications. Diodes does not convey any license under any of its intellectual property rights or the rights of any third parties (including third parties whose products and services may be described in this document or on Diodes' website) under this document.
5. Diodes' products are provided subject to Diodes' Standard Terms and Conditions of Sale (<https://www.diodes.com/about/company/terms-and-conditions/terms-and-conditions-of-sales/>) or other applicable terms. This document does not alter or expand the applicable warranties provided by Diodes. Diodes does not warrant or accept any liability whatsoever in respect of any products purchased through unauthorized sales channel.
6. Diodes' products and technology may not be used for or incorporated into any products or systems whose manufacture, use or sale is prohibited under any applicable laws and regulations. Should customers or users use Diodes' products in contravention of any applicable laws or regulations, or for any unintended or unauthorized application, customers and users will (a) be solely responsible for any damages, losses or penalties arising in connection therewith or as a result thereof, and (b) indemnify and hold Diodes and its representatives and agents harmless against any and all claims, damages, expenses, and attorney fees arising out of, directly or indirectly, any claim relating to any noncompliance with the applicable laws and regulations, as well as any unintended or unauthorized application.
7. While efforts have been made to ensure the information contained in this document is accurate, complete and current, it may contain technical inaccuracies, omissions and typographical errors. Diodes does not warrant that information contained in this document is error-free and Diodes is under no obligation to update or otherwise correct this information. Notwithstanding the foregoing, Diodes reserves the right to make modifications, enhancements, improvements, corrections or other changes without further notice to this document and any product described herein. This document is written in English but may be translated into multiple languages for reference. Only the English version of this document is the final and determinative format released by Diodes.
8. Any unauthorized copying, modification, distribution, transmission, display or other use of this document (or any portion hereof) is prohibited. Diodes assumes no responsibility for any losses incurred by the customers or users or any third parties arising from any such unauthorized use.
9. This Notice may be periodically updated with the most recent version available at <https://www.diodes.com/about/company/terms-and-conditions/important-notice>

The Diodes logo is a registered trademark of Diodes Incorporated in the United States and other countries.
All other trademarks are the property of their respective owners.
© 2024 Diodes Incorporated. All Rights Reserved.

www.diodes.com

Looking for pricing, stock, or lifecycle information?

Click below to explore more details on WIN SOURCE:

 [View PI6CG33401CZHIEX on WIN SOURCE](#)

 [Diodes Incorporated](#) Information

Optimize Your Supply Chain with WIN SOURCE Solutions

-  Global Sourcing Solution
-  Obsolete Management
-  Cost Control Management
-  Shortage Management
-  Alternative Solution
-  Excess Inventory Management