



**THE DATASHEET OF
SS4-30-3.50-L-D-K-TR**



DESIGNED & DIMENSIONED
IN MILLIMETERS [INCHES]

SS4-XX-X.XX-X-D-X-XX-XR

DO NOT
SCALE FROM
THIS PRINT

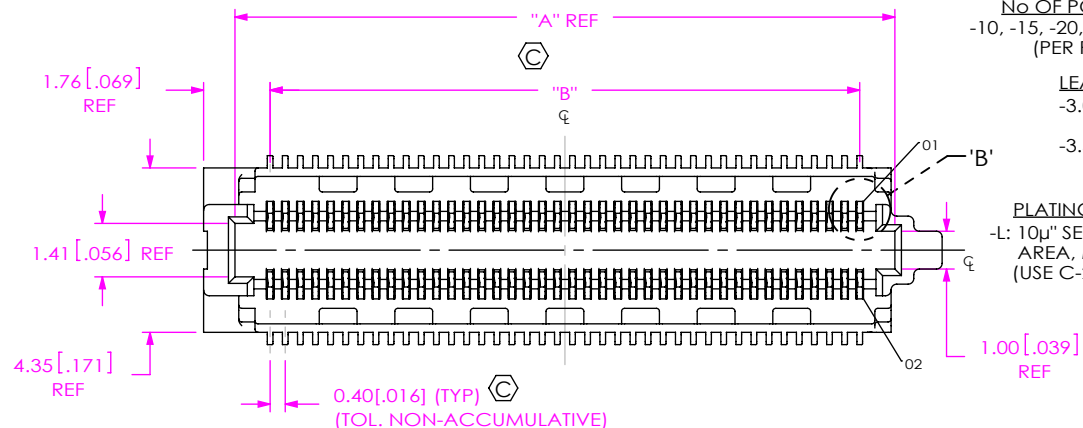

No OF POSITIONS
-10, -15, -20, -30, -40, -50
(PER ROW)

LEAD STYLE
-3.00: SEE FIG 1
(USE C-229-3.00-X)
-3.50: SEE FIG 2, SHT 2
(USE C-229-3.50-X)

PLATING
-L: 10µ" SELECTIVE GOLD IN CONTACT
AREA, MATTE TIN ON TAIL
(USE C-229-X.XX-X)

ROW SPECIFICATION
-D: DOUBLE

TAPE & REEL (SEE NOTES 5 & 6)
-TR: TAPE & REEL
-FR: FULL REEL QTY TAPE & REEL

PLACEMENT PAD
-K: KAPTON PAD
(USE K-DOT-.138-.250-.005)
(SEE FIG 4 & 5, SHT 3)
**-PA: PICK & PLACE WITH
ALIGNMENT PINS
(SEE FIG 6, SHT 4)
(NOT AVAILABLE IN -15 POS)

OPTIONS
*, **-L: LATCHING
(USE WT-40-X.XX-T)
(SEE FIG 3, SHT 2 AND NOTE 3)
(LEAVE BLANK FOR NO OPTION)

* = TOOLED ONLY FOR THE -3.00 LEAD STYLE
** = AVAILABLE FOR EXISTING CUSTOMERS ONLY

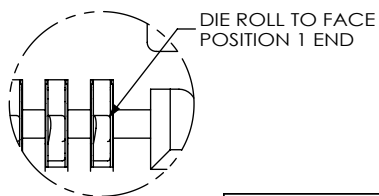
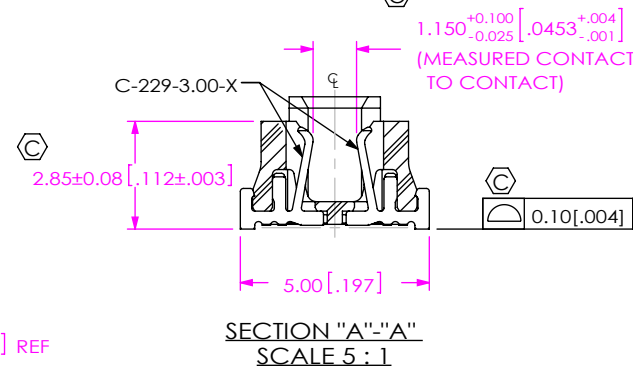
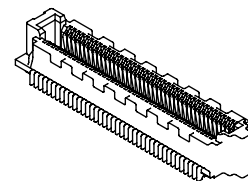
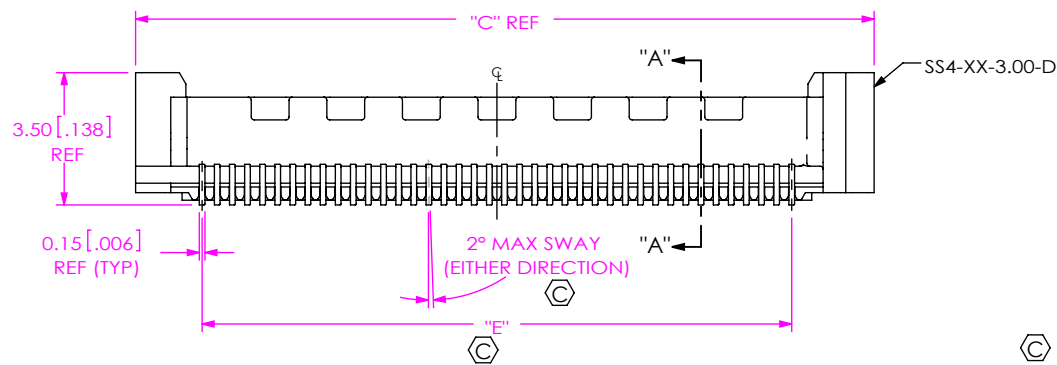

POS	"A"	"B"	"C"	"E"
-10	5.46 [0.215]	3.60 [0.142]	7.54 [0.297]	3.60 [0.142]
-15	7.46 [0.294]	5.60 [0.220]	9.54 [0.376]	5.60 [0.220]
-20	9.46 [0.372]	7.60 [0.299]	11.54 [0.454]	7.60 [0.299]
-30	13.46 [0.530]	11.60 [0.457]	15.54 [0.612]	11.60 [0.457]
-40	17.46 [0.687]	15.60 [0.614]	19.54 [0.769]	15.60 [0.614]
-50	21.46 [0.845]	19.60 [0.772]	23.54 [0.927]	19.60 [0.772]

FIG 1
SS4-40-3.00-L-D SHOWN

SS4 LEAD STYLE	TABLE 2 REF STACK HEIGHT		
	ST4 LEAD STYLE		
-1.00	-1.00	-1.50	-2.50
-3.00	4.0 [0.16]	4.5 [0.18]	5.5 [0.22]
-3.50	4.5 [0.18]	5.0 [0.20]	6.0 [0.24]

NOTES:

- REPRESENTS A CRITICAL DIMENSION.
- MINIMUM PUSHOUT FORCE: 1.11 N [0.25 LB].
- L: LATCHING OPTION NOT INTENDED FOR ALIGNMENT TO PCB. AUTOMATED PLACEMENT IS RECOMMENDED.
- NOTE DELETED.
- ORDERS WILL BE PACKAGED ACCORDING TO THE SAMTEC PACKAGING EFFICIENCY STANDARDS (SPES) FOUND ON WWW.SAMTEC.COM.
- ATTACH LABEL TO EACH REEL.

UNLESS OTHERWISE SPECIFIED,
DIMENSIONS ARE IN MILLIMETERS.
TOLERANCES ARE:
DECIMALS ANGLES
.X: ±0.3 [0.1] 2°
.XX: ±0.13 [0.05]
.XXX: ±0.051 [0.020]

PROPRIETARY NOTE
THIS DOCUMENT CONTAINS CONFIDENTIAL AND PROPRIETARY INFORMATION AND ALL DESIGN, MANUFACTURING, REPRODUCTION, USE, PATENT RIGHTS AND SALES RIGHTS ARE EXPRESSLY RESERVED BY SAMTEC, INC. THIS DOCUMENT SHALL NOT BE DISCLOSED, IN WHOLE OR PART, TO ANY UNAUTHORIZED PERSON OR ENTITY NOR REPRODUCED, TRANSFERRED OR INCORPORATED IN ANY OTHER PROJECT IN ANY MANNER WITHOUT THE EXPRESS WRITTEN CONSENT OF SAMTEC, INC.

MATERIAL: DO NOT SCALE DRAWING SHEET SCALE: 2:1
INSULATOR: LCP, UL 94 V0, COLOR: BLACK
CONTACT: PHOS BRONZE
LATCH: PHOS BRONZE

DESCRIPTION:
0.4mm [0.016] SOCKET STRIP ASSEMBLY
DWG. NO.
SS4-XX-X.XX-X-D-X-XX-XR
BY: CLAY W 4/19/2007 SHEET 1 OF 4



520 PARK EAST BLVD, NEW ALBANY, IN 47150
PHONE: 812-944-6733 FAX: 812-948-5047
e-Mail: info@SAMTEC.com code: 55322

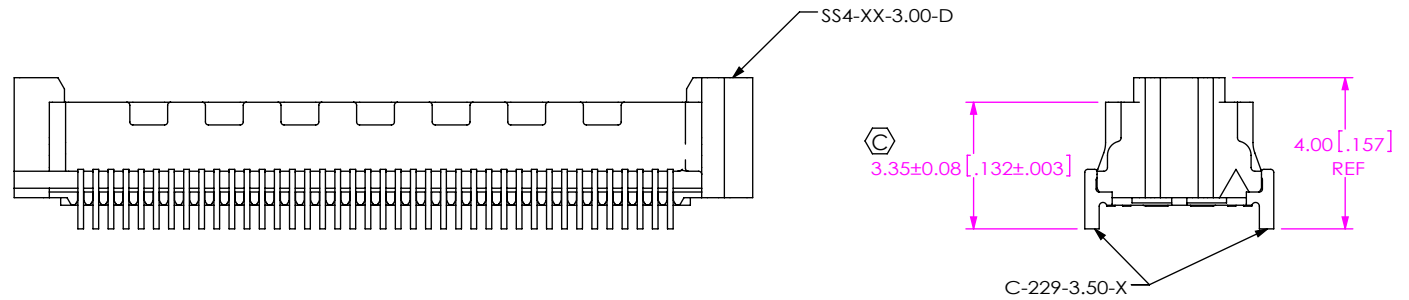

FIG 2
-3.50 BODY HEIGHT
SS4-40-3.50-X-D SHOWN
(DIFFERENT AS SHOWN, OTHERWISE SAME AS FIG 1)

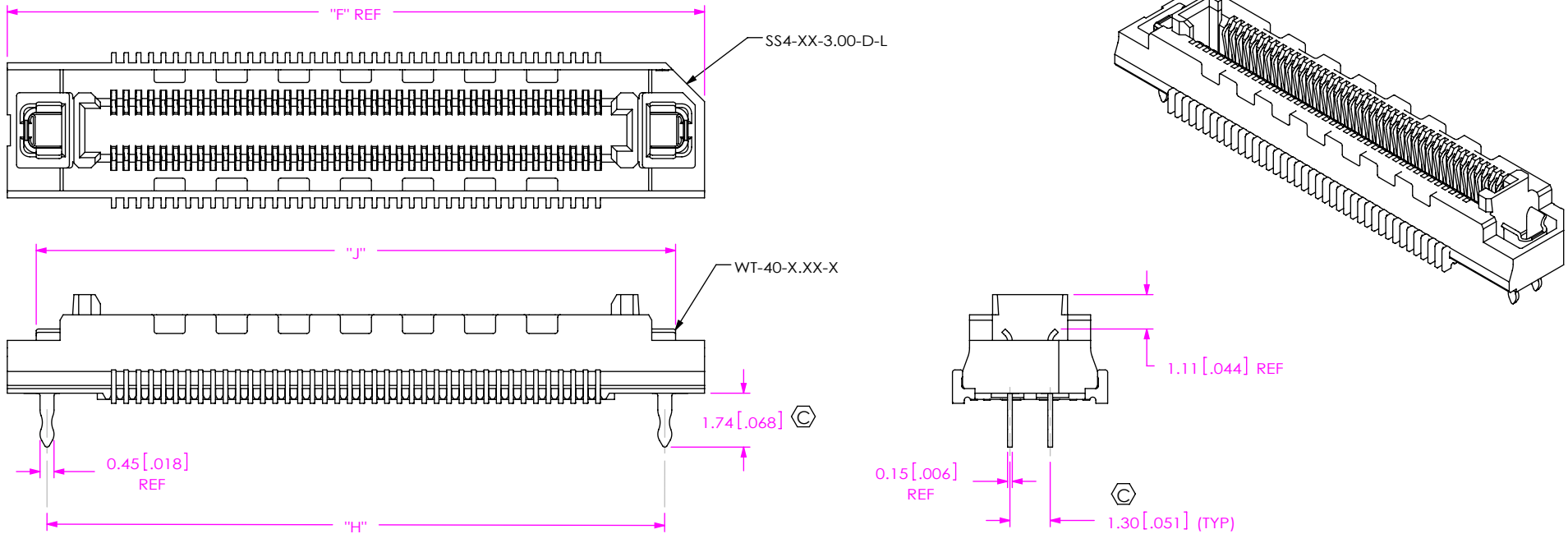

FIG 3
-L: LATCHING OPTION
SS4-40-3.00-X-D-L SHOWN
(DIFFERENT AS SHOWN, OTHERWISE SAME AS FIG 1)

POS	"F"	"H"	"J"
-10	10.46 [0.412]	7.90 [0.311]	8.60 [0.339]
-15	12.46 [0.491]	9.90 [0.390]	10.60 [0.417]
-20	14.46 [0.569]	11.90 [0.469]	12.60 [0.496]
-30	18.46 [0.727]	15.90 [0.626]	16.60 [0.654]
-40	22.46 [0.884]	19.90 [0.783]	20.60 [0.811]
-50	26.46 [1.042]	23.90 [0.941]	24.60 [0.969]

LEAD STYLE	LATCH
-3.00	W-40-3.00-T
-3.50	WT-40-3.50-T

PROPRIETARY NOTE
THIS DOCUMENT CONTAINS CONFIDENTIAL AND PROPRIETARY INFORMATION AND ALL DESIGN, MANUFACTURING, REPRODUCTION, USE, PATENT RIGHTS AND SALES RIGHTS ARE EXPRESSLY RESERVED BY SAMTEC, INC. THIS DOCUMENT SHALL NOT BE DISCLOSED, IN WHOLE OR PART, TO ANY UNAUTHORIZED PERSON OR ENTITY NOR REPRODUCED, TRANSFERRED OR INCORPORATED IN ANY OTHER PROJECT IN ANY MANNER WITHOUT THE EXPRESS WRITTEN CONSENT OF SAMTEC, INC.

DO NOT SCALE DRAWING

SHEET SCALE: 5:1



520 PARK EAST BLVD, NEW ALBANY, IN 47150
PHONE: 812-944-6733 FAX: 812-948-5047
e-Mail: info@SAMTEC.com code: 55322

DESCRIPTION:
0.4mm [0.016] SOCKET STRIP ASSEMBLY

DWG. NO.
SS4-XX-X.XX-X-D-X-XX-XR

BY: CLAY W 4/19/2007 SHEET 2 OF 4

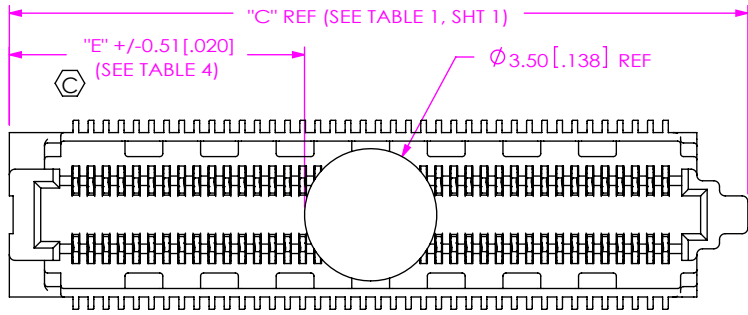

FIG 4
-K: KAPTON OPTION
SS4-40-3.00-X-D-K SHOWN
(DIFFERENT AS SHOWN, OTHERWISE SAME AS FIG 1)

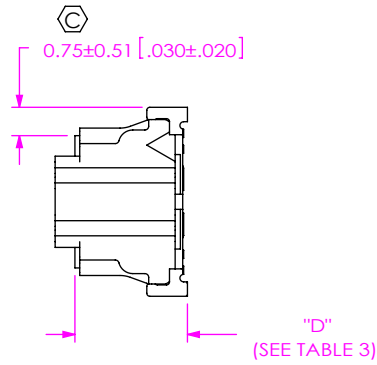

TABLE 3	
LEAD STYLE	"D"
-3.00	2.98 [.117]
-3.50	3.48 [.137]

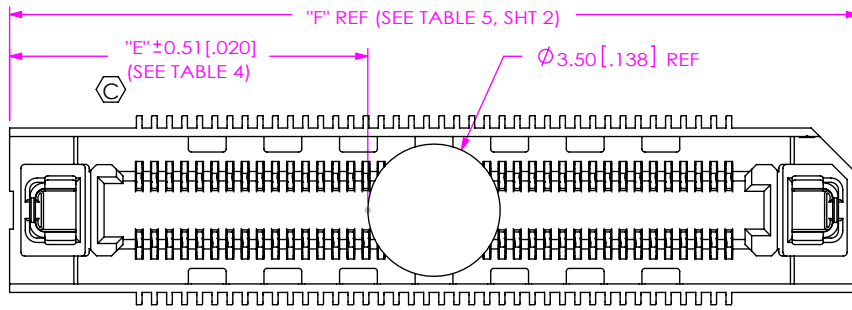

FIG 5
-K: KAPTON OPTION(W/ -L OPTION)
SS4-40-3.00-X-D-L-K SHOWN
(DIFFERENT AS SHOWN, OTHERWISE SAME AS FIG 1)

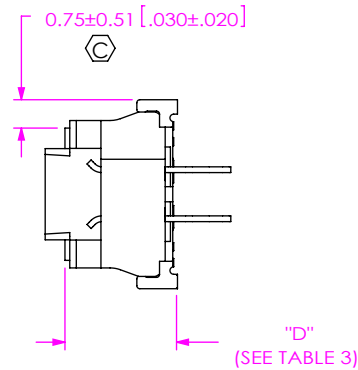

TABLE 4		
POS	"E" W/O -L OPTION	"E" W/ -L OPTION
-10	1.81 [0.071]	3.48 [0.137]
-15	2.81 [0.111]	4.48 [0.176]
-20	3.81 [0.150]	5.48 [0.216]
-30	5.81 [0.229]	7.48 [0.294]
-40	7.81 [0.307]	9.48 [0.373]
-50	9.81 [0.386]	11.48 [0.452]

PROPRIETARY NOTE

THIS DOCUMENT CONTAINS CONFIDENTIAL AND PROPRIETARY INFORMATION AND ALL DESIGN, MANUFACTURING, REPRODUCTION, USE, PATENT RIGHTS AND SALES RIGHTS ARE EXPRESSLY RESERVED BY SAMTEC, INC. THIS DOCUMENT SHALL NOT BE DISCLOSED, IN WHOLE OR PART, TO ANY UNAUTHORIZED PERSON OR ENTITY NOR REPRODUCED, TRANSFERRED OR INCORPORATED IN ANY OTHER PROJECT IN ANY MANNER WITHOUT THE EXPRESS WRITTEN CONSENT OF SAMTEC, INC.

DO NOT SCALE DRAWING

SHEET SCALE: 5:1



520 PARK EAST BLVD, NEW ALBANY, IN 47150
PHONE: 812-944-6733 FAX: 812-948-5047
e-Mail: info@SAMTEC.com code: 55322

DESCRIPTION:
0.4mm[.016] SOCKET STRIP ASSEMBLY

DWG. NO.
SS4-XX-X.XX-X-D-X-XX-XR

BY: CLAY W 4/19/2007 SHEET 3 OF 4

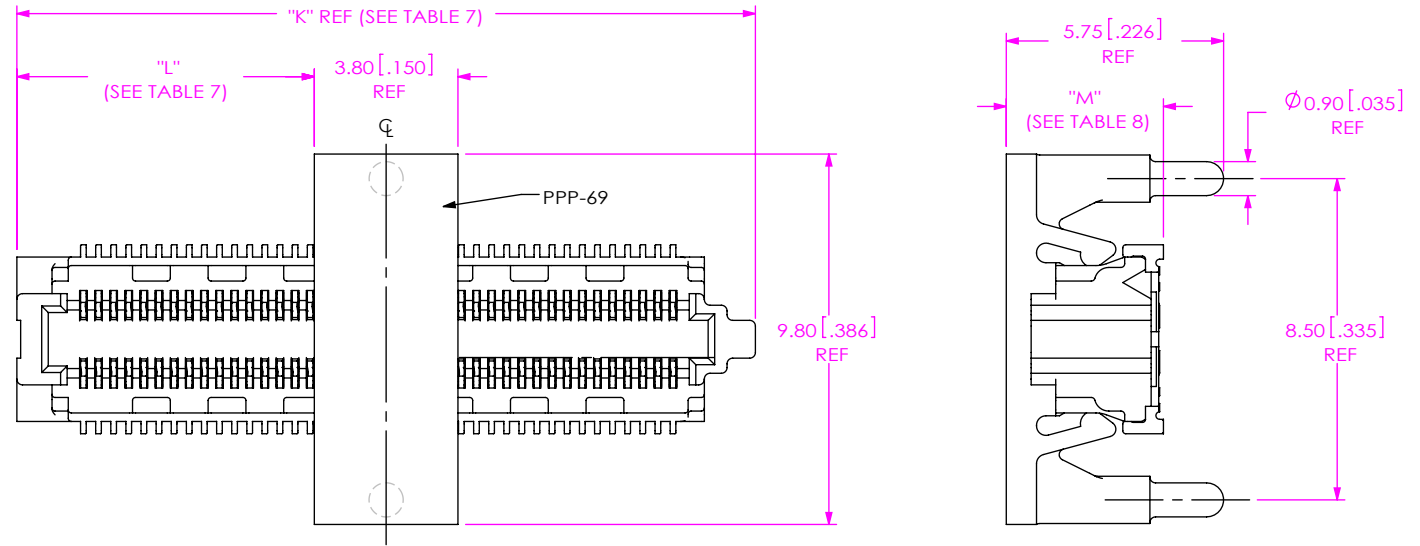

FIG 6
 SS4-40-3.00-X-D-PA SHOWN
 (DIFFERENT AS SHOWN, OTHERWISE SAME AS FIG 1)
 (NOT AVAILABLE IN -15 POS)

LEAD STYLE	"M"
-3.00	4.16 [.164]
-3.50	4.66 [.183]

POS	"K"	"K"	"L"	"L"
	W/O -L OPTION	W/ -L OPTION	W/O -L OPTION	W/ -L OPTION
-10	7.54 [0.297]	10.46 [0.412]	1.87 [0.074]	3.33 [0.131]
-20	11.54 [0.454]	14.46 [0.569]	3.87 [0.152]	5.33 [0.210]
-30	15.54 [0.612]	18.46 [0.727]	5.87 [0.231]	7.33 [0.289]
-40	19.54 [0.769]	22.46 [0.884]	7.87 [0.310]	9.33 [0.367]
-50	23.54 [0.927]	26.46 [1.042]	9.87 [0.389]	11.33 [0.446]

PROPRIETARY NOTE
 THIS DOCUMENT CONTAINS CONFIDENTIAL AND PROPRIETARY INFORMATION AND ALL DESIGN, MANUFACTURING, REPRODUCTION, USE, PATENT RIGHTS AND SALES RIGHTS ARE EXPRESSLY RESERVED BY SAMTEC, INC. THIS DOCUMENT SHALL NOT BE DISCLOSED, IN WHOLE OR PART, TO ANY UNAUTHORIZED PERSON OR ENTITY NOR REPRODUCED, TRANSFERRED OR INCORPORATED IN ANY OTHER PROJECT IN ANY MANNER WITHOUT THE EXPRESS WRITTEN CONSENT OF SAMTEC, INC.

DO NOT SCALE DRAWING

SHEET SCALE: 5:1



520 PARK EAST BLVD, NEW ALBANY, IN 47150
 PHONE: 812-944-6733 FAX: 812-948-5047
 e-Mail: info@SAMTEC.com code: 55322

DESCRIPTION:
 0.4mm [.016] SOCKET STRIP ASSEMBLY

DWG. NO.
 SS4-XX-X.XX-X-D-X-XX-XR

BY: CLAY W 4/19/2007 SHEET 4 OF 4

Looking for pricing, stock, or lifecycle information?

Click below to explore more details on WIN SOURCE:

 [View SS4-30-3.50-L-D-K-TR on WIN SOURCE](#)

 [Samtec Inc. Information](#)

Optimize Your Supply Chain with WIN SOURCE Solutions

-  Global Sourcing Solution
-  Obsolete Management
-  Cost Control Management
-  Shortage Management
-  Alternative Solution
-  Excess Inventory Management