



**THE DATASHEET OF  
TSM-105-01-L-DV-P**



DO NOT SCALE FROM THIS PRINT

NOTES:

- ⊙ REPRESENTS A CRITICAL DIMENSION.
- MAXIMUM POST HEIGHT VARIATION: .005[0.13].
- LOAD PARTS POS 1 IN SAME DIRECTION AS ARROW.
- TUBE POSITIONS 03 THRU 50.
- TAPE & REEL AVAILABLE ON POSITION 02 THRU 28 ONLY.  
LEADS MAY NOT BE VISIBLE FOR CUSTOMER'S VISUAL INSPECTION ON SMALLER POSITIONED PARTS WHEN USED WITH THE -P OR -M OPTIONS.
- MEASURE AT BEND RADIUS.
- MINIMUM PUSHOUT FORCE: 3 LBS.
- FOR -TV USE T-31724-01.
- DUE TO THE HIGH AMOUNT OF INSERTION FORCE NEEDED, THE -LC OPTION IS NOT COMPATIBLE WITH AUTO PLACEMENT. SAMTEC RECOMMENDS MANUAL PLACEMENT FOR ALL ASSEMBLIES WITH THE -LC OPTION.
- ONLY AVAILABLE ON -01-DV OPTION, MATES ONLY WITH SSM, SSW, SSQ, BCS, ESW AND ESQ.
- MAXIMUM ALLOWABLE CUT FLASH .010[0.25], .015[0.38] ALLOWED TOWARDS TAILS.
- THIS DIMENSION TO BE MEASURED RELATIVE TO DATUM -Z-.
- FR OPTIONS WILL BE SHIPPED AT THE MAX QUANTITY PER REEL, BASED ON OPTIONS SELECTED.

MOUNT STYLE	POSITIONS	COPLANARITY
-DV	-02 THRU -05	.004 [0.10]
	-06 THRU -10	.005 [0.13]
	-11 THRU -50	.006 [0.15]
-TV & -TM	-02 THRU -10	.004 [0.10]
	-11 THRU -20	.005 [0.13]
	-21 THRU -30	.006 [0.15]

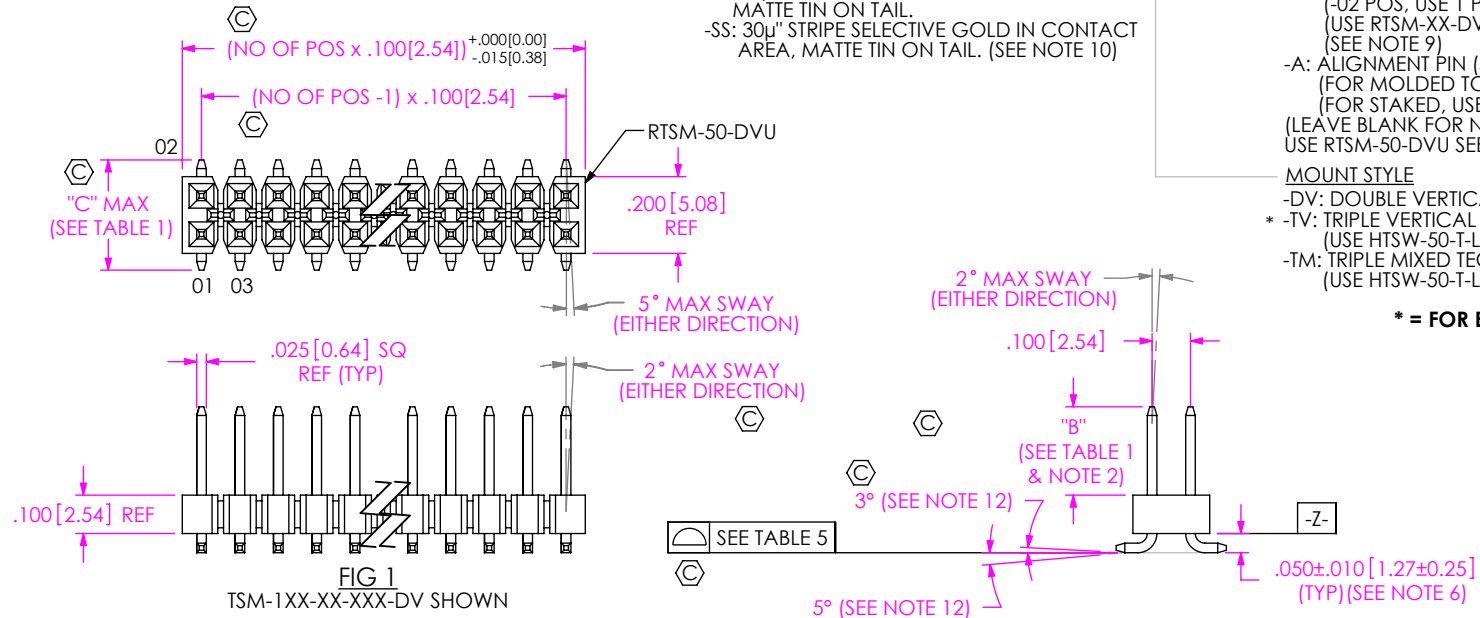


FIG 1  
TSM-1XX-XX-XXX-DV SHOWN

TSM-1XX-XX-XXX-XX-X-XXX-X

No OF POSITIONS  
-02 THRU -50

LEAD STYLE  
(SEE TABLE 1)

PLATING SPECIFICATION

- T: MATTE TIN ON ENTIRE PIN.
- S: 30μ" SELECTIVE GOLD IN CONTACT AREA, MATTE TIN ON TAIL.
- G: 10μ" SELECTIVE GOLD IN CONTACT AREA, 3μ" SELECTIVE GOLD ON TAIL.
- L: 10μ" SELECTIVE GOLD IN CONTACT AREA, MATTE TIN ON TAIL.
- TL: TIN/LEAD (90/10) ON ENTIRE PIN.
- STL: 30μ" SELECTIVE GOLD IN CONTACT AREA, TIN/LEAD (90/10) ON TAIL.
- F: 3μ" SELECTIVE GOLD IN CONTACT AREA, MATTE TIN ON TAIL.
- H: 30μ" SELECTIVE GOLD IN CONTACT AREA, 3μ" SELECTIVE GOLD ON TAIL.
- TM: MATTE TIN ON ENTIRE PIN.
- SM: 30μ" SELECTIVE GOLD IN CONTACT AREA, MATTE TIN ON TAIL.
- LM: 10μ" SELECTIVE GOLD IN CONTACT AREA, MATTE TIN ON TAIL.
- FM: 3μ" SELECTIVE GOLD IN CONTACT AREA, MATTE TIN ON TAIL.
- SS: 30μ" STRIPE SELECTIVE GOLD IN CONTACT AREA, MATTE TIN ON TAIL. (SEE NOTE 10)

OPTION #3

- (NOT AVAILABLE WITH -TV & -TM MOUNT STYLES)
- P: PICK AND PLACE PAD  
(POS -04 THRU -36, 50 USE PPP-06, SEE FIG 4, SHT 2)  
(POS -02, USE PPP-81, SEE FIG 9, SHT 2)  
(POS -03, USE PPP-86, SEE FIG 10, SHT 2)  
(AVAILABLE ON POS -02 & -03 WITH -TR & -FR OPTION ONLY)
- \*-M: METAL PICK AND PLACE PAD

\* FOR EXISTING CUSTOMERS ONLY

- (USE LMP-01, SEE FIG 5, SHT 2)
- (NOT RECOMMENDED WITH -T OR -TM PLATING)
- (LEAD STYLES -01 & -04 ONLY)
- (AVAILABLE ON POS 04 THRU 36)
- (AVAILABLE ON POS 02 AND 03 WITH -TR & -FR OPTION ONLY, SEE NOTE 5)
- TR: TAPE AND REEL (SEE FIG 8, SHT 3)  
(02 THRU 28 POS)
- FR: FULL REEL QTY. TAPE & REEL (SEE FIG 8, SHT 3)  
(02 THRU 28 POS)(SEE NOTE 13)

OPTION #2

- POLARIZED POSITION
- SPECIFY OMITTED PIN

OPTION #1

- (AVAILABLE FOR -DV MOUNT STYLE ONLY)
- LC: LOCKING CLIP (SEE FIG 2, SHT 2)

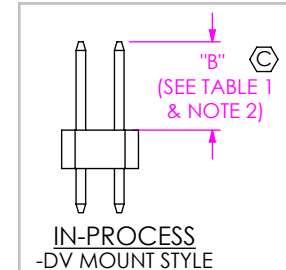
- (USE LC-05-TM)
- (-03 THRU -36 POS, USE 2 PER STRIP)
- (-02 POS, USE 1 PER STRIP)
- (USE RTSM-XX-DVU)
- (SEE NOTE 9)

- A: ALIGNMENT PIN (SEE FIG 3, SHT 2)
- (FOR MOLDED TO POSITION, USE RTSM-XX-DVU-XX BODY)
- (FOR STAKED, USE RTSM-50-DVU BODY, 5 POS MIN)
- (LEAVE BLANK FOR NO HOLD DOWN OPTION)
- USE RTSM-50-DVU SEE FIG 1, CAN BE CUT TO POSITION)

MOUNT STYLE

- DV: DOUBLE VERTICAL
- \* -TV: TRIPLE VERTICAL (-02 THRU -30 ONLY)  
(USE HTSW-50-T-LCP, SEE NOTE 8)
- TM: TRIPLE MIXED TECHNOLOGY (-02 THRU -30 ONLY)  
(USE HTSW-50-T-LCP, AVAILABLE ON -01 LEAD STYLE ONLY)

\* = FOR EXISTING CUSTOMERS ONLY



IN-PROCESS  
-DV MOUNT STYLE

LEAD STYLE	MOUNT STYLE	"B"	"C"	"D"	TERMINAL	OVERALL PIN LENGTH
-01	-DV	0.230 [5.84]	0.303 [7.70]	0.280 [7.11]	T-1S6-16-X-2	0.445 [11.30] REF
	-TM, -TV	0.230 [5.84]	---	---	T-1S6-17-X-2	0.480 [12.19] REF
-02	-DV	0.320 [8.13]	0.293 [7.44]	0.370 [9.40]	T-1S6-08-X-2	0.530 [13.46] REF
-03	-DV	0.420 [10.67]	0.293 [7.44]	0.470 [11.94]	T-1S6-15-X-2	0.630 [16.00] REF
-04	-DV	0.120 [3.05]	0.303 [7.70]	0.270 [6.86]	T-1S6-21-X-2	0.335 [8.51] REF
-05	-DV	0.075 [1.91]	0.323 [8.20]	0.270 [6.86]	T-1S6-18-X-2	0.300 [7.62] REF

UNLESS OTHERWISE SPECIFIED, DIMENSIONS ARE IN INCHES.

TOLERANCES ARE:

- DECIMALS
- ANGLES
- .XX: ±.01 [.3]
- .XXX: ±.005 [.13]
- .XXXX: ±.0020 [.051]

PROPRIETARY NOTE  
THIS DOCUMENT CONTAINS CONFIDENTIAL AND PROPRIETARY INFORMATION AND ALL DESIGN, MANUFACTURING, REPRODUCTION, USE, PATENT RIGHTS AND SALES RIGHTS ARE EXPRESSLY RESERVED BY SAMTEC, INC. THIS DOCUMENT SHALL NOT BE DISCLOSED, IN WHOLE OR PART, TO ANY UNAUTHORIZED PERSON OR ENTITY NOR REPRODUCED, TRANSFERRED OR INCORPORATED IN ANY OTHER PROJECT IN ANY MANNER WITHOUT THE EXPRESS WRITTEN CONSENT OF SAMTEC, INC.

MATERIAL: DO NOT SCALE DRAWING SHEET SCALE: 2:1  
INSULATOR: LCP, UL94V0, COLOR: BLACK  
TERMINAL: PHOS BRONZE

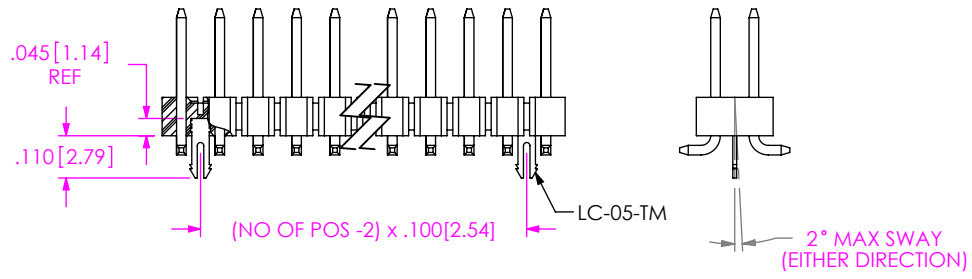
DESCRIPTION: DOUBLE ROW GULLWING ASM

DWG. NO. TSM-1XX-XX-XXX-XX-X-XXX-X

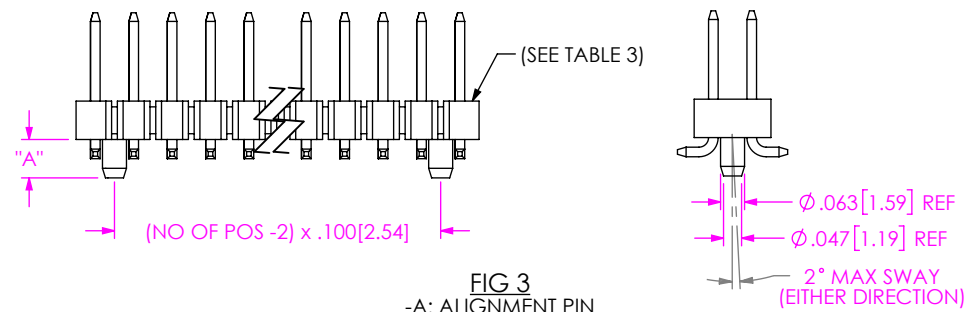
BY: BRYANT 04/24/1991 SHEET 1 OF 3

TABLE 3			
	"A"	BODY	MIN NO OF POS
MOLDED	.100[2.54] REF	RTSM-50-DVU-XX	2
*STAKED	.100[2.54]	RTSM-50-DVU-XX	5

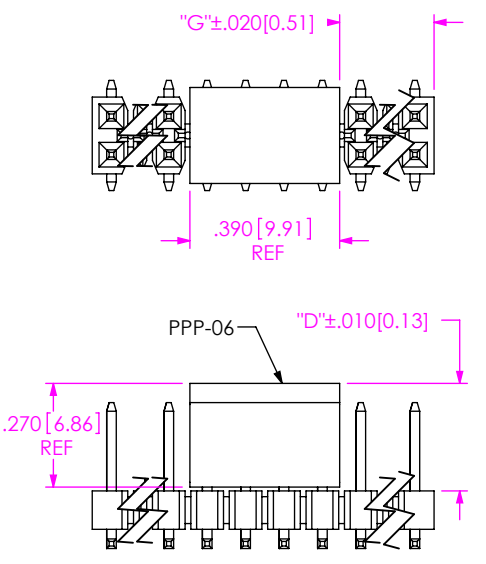
\* = USE TWO SM-AH'S



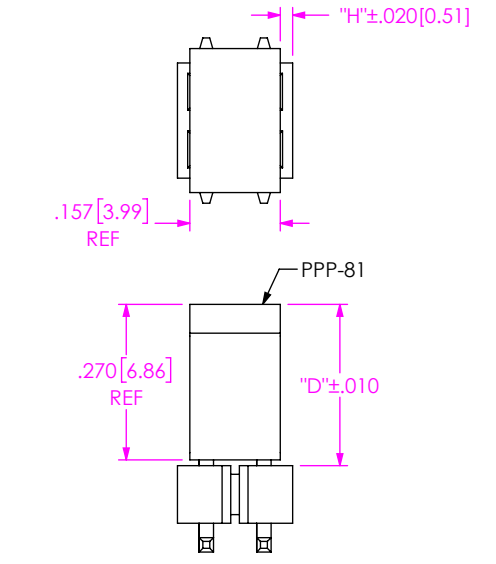
**FIG 2**  
-LC: LOCKING CLIP  
(DIFFERENT AS SHOWN, OTHERWISE SAME AS FIG 1)



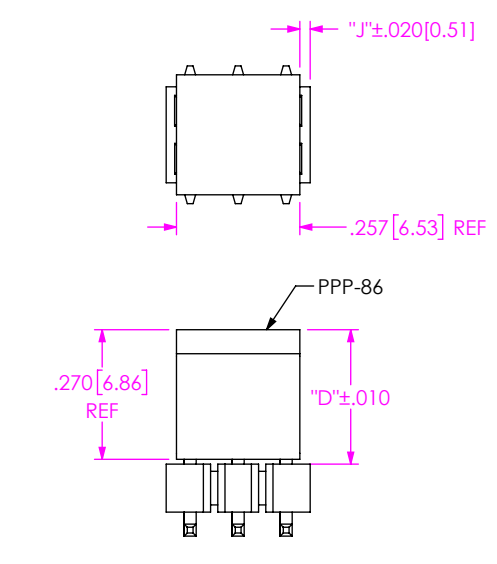
**FIG 3**  
-A: ALIGNMENT PIN  
(DIFFERENT AS SHOWN, OTHERWISE SAME AS FIG 1)



**FIG 4**  
-P: PICK AND PLACE PAD  
(DIFFERENT AS SHOWN, OTHERWISE SAME AS FIG 1)  
 $"G" = ((NO\ OF\ POS \times .100[2.54]) - .390[9.91])/2$

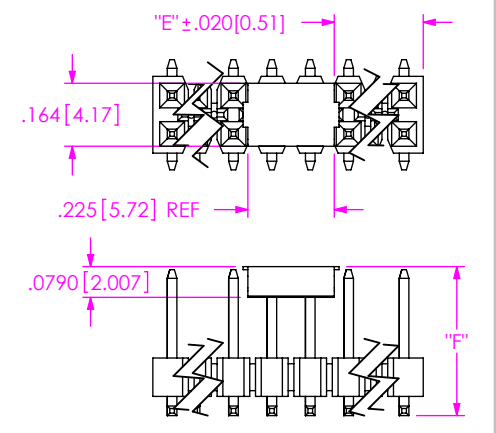


**FIG 9**  
-P: PICK AND PLACE PAD  
(-02 POS ONLY)  
(DIFFERENT AS SHOWN, OTHERWISE SAME AS FIG 1)  
 $"H" = ((NO\ OF\ POS \times .100[2.54]) - .157[3.99])/2$



**FIG 10**  
-P: PICK AND PLACE PAD  
(-03 POS ONLY)  
(DIFFERENT AS SHOWN, OTHERWISE SAME AS FIG 1)  
 $"J" = ((NO\ OF\ POS \times .100[2.54]) - .257[6.53])/2$

TABLE 2	
LEAD STYLE	"F"
-01	0.388[9.86]
-04	0.278[7.06]



**FIG 5**  
-M: METAL PICK AND PLACE PAD  
(DIFFERENT AS SHOWN, OTHERWISE SAME AS FIG 1)  
 $"E" = ((NO\ OF\ POS \times .100[2.54]) - .225[5.72]) / 2$   
NOTE:  
HAND FILL USE LMP-01  
MACHINE FILL USE LMP-01

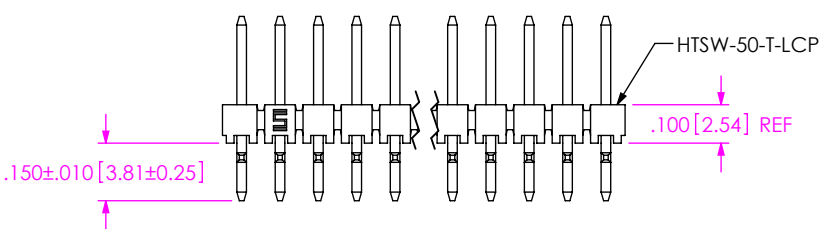
**PROPRIETARY NOTE**  
THIS DOCUMENT CONTAINS CONFIDENTIAL AND PROPRIETARY INFORMATION AND ALL DESIGN, MANUFACTURING, REPRODUCTION, USE, PATENT RIGHTS AND SALES RIGHTS ARE EXPRESSLY RESERVED BY SAMTEC, INC. THIS DOCUMENT SHALL NOT BE DISCLOSED, IN WHOLE OR PART, TO ANY UNAUTHORIZED PERSON OR ENTITY NOR REPRODUCED, TRANSFERRED OR INCORPORATED IN ANY OTHER PROJECT IN ANY MANNER WITHOUT THE EXPRESS WRITTEN CONSENT OF SAMTEC, INC.

DO NOT SCALE DRAWING  
SHEET SCALE: 2:1

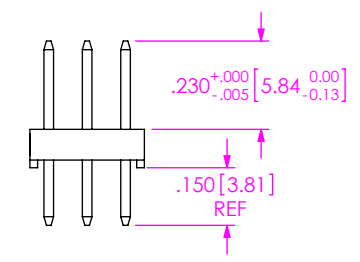
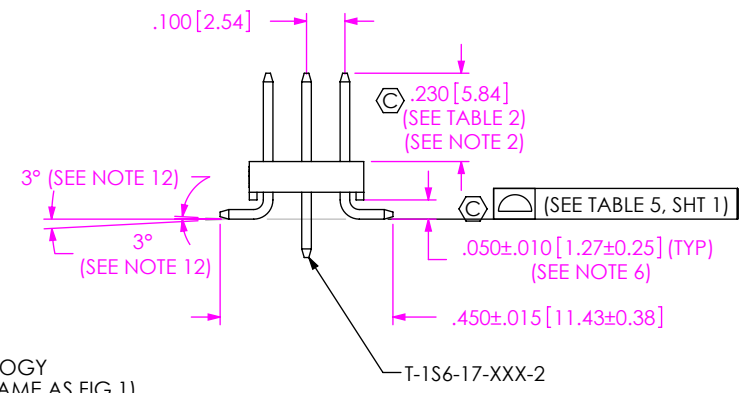


520 PARK EAST BLVD, NEW ALBANY, IN 47150  
PHONE: 812-944-6733 FAX: 812-948-5047  
e-Mail info@SAMTEC.com code 55322

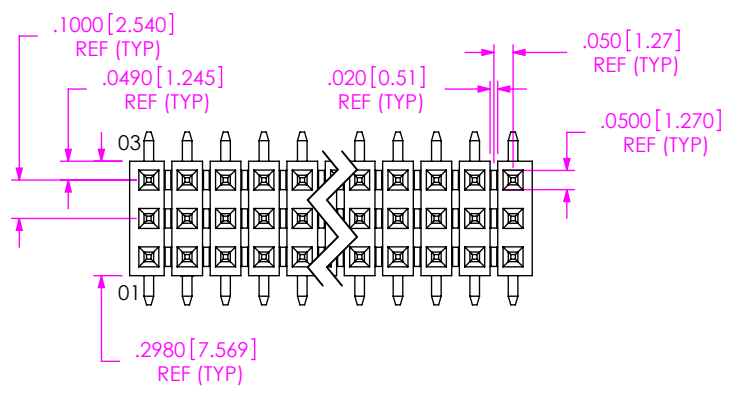
DESCRIPTION: DOUBLE ROW GULLWING ASM  
DWG. NO. TSM-1XX-XX-XXX-XX-X-XXX-X  
BY: BRYANT 04/24/1991 SHEET 2 OF 3



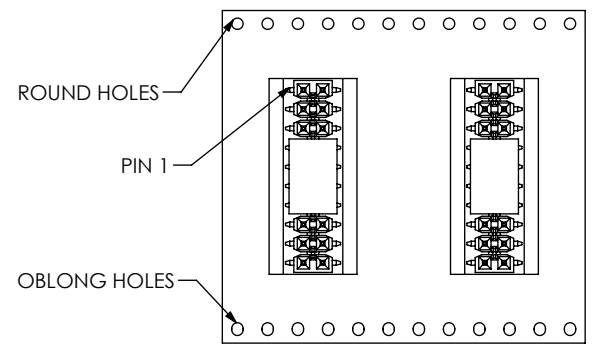
**FIG 6**  
-TM: TRIPLE MIXED TECHNOLOGY  
(DIFFERENT AS SHOWN, OTHERWISE SAME AS FIG 1)



**IN-PROCESS**  
-TM MOUNT STYLE

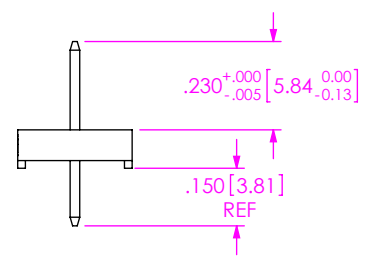


**FIG 7**  
-TV: TRIPLE VERTICAL  
(DIFFERENT AS SHOWN, OTHERWISE SAME AS FIG 6)  
**FOR EXISTING CUSTOMERS ONLY**

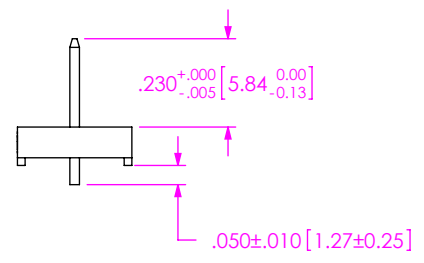


**FIG 8**  
PACKAGING VIEWS

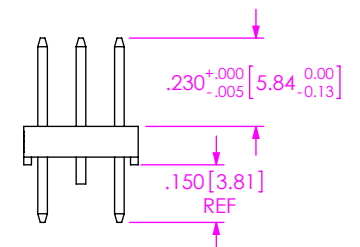
TABLE 4					
LEAD STYLE	MOUNT STYLE	OPTION	TUBE	PLUG	NOTE
01, 02, 04, 05	-DV	NONE	PT-1-24-01-29	TP-03	4
01, 02	-DV	-LC, -A	PT-1-24-01-29	TP-03	4
01, 04, 05	-DV	-P	PT-1-24-06-29	TP-03	4
01, 04, 05	-DV	-LC-P, -A-P	PT-1-24-06-29	TP-03	4
02	-DV	-P	PT-1-24-15-29	TP-07	4
02	-DV	-LC-P, -A-P	PT-1-24-15-29	TP-07	4
03	-DV	NONE	PT-1-24-09-29	TP-03	4
03	-DV	-LC, -A	PT-1-24-09-29	TP-03	4
03	-DV	-P	PT-1-24-16-29	TP-03	4
03	-DV	-LC-P, -A-P	PT-1-24-16-29	TP-03	4
04, 05	-DV	-LC, -A	PT-1-24-03-15	TP-03	4
01, 04, 05	-DV	-M, -LC-M, -A-M, -LC-A-M	PT-TSM004-DV	TP-03	4
01	-TM	NONE	PT-1-24-02-08	TP-13	4
01	-TV	NONE	PT-1-24-01-70	TP-07	4



**IN-PROCESS 1**  
-TV MOUNT STYLE



**IN-PROCESS 2**  
-TV MOUNT STYLE



**IN-PROCESS 3**  
-TV MOUNT STYLE

**PROPRIETARY NOTE**  
THIS DOCUMENT CONTAINS CONFIDENTIAL AND PROPRIETARY INFORMATION AND ALL DESIGN, MANUFACTURING, REPRODUCTION, USE, PATENT RIGHTS AND SALES RIGHTS ARE EXPRESSLY RESERVED BY SAMTEC, INC. THIS DOCUMENT SHALL NOT BE DISCLOSED, IN WHOLE OR PART, TO ANY UNAUTHORIZED PERSON OR ENTITY NOR REPRODUCED, TRANSFERRED OR INCORPORATED IN ANY OTHER PROJECT IN ANY MANNER WITHOUT THE EXPRESS WRITTEN CONSENT OF SAMTEC, INC.

DO NOT SCALE DRAWING  
SHEET SCALE: 2:1



520 PARK EAST BLVD, NEW ALBANY, IN 47150  
PHONE: 812-944-6733 FAX: 812-948-5047  
e-Mail info@SAMTEC.com code 55322


DESCRIPTION: **DOUBLE ROW GULLWING ASM**

DWG. NO. **TSM-1XX-XX-XXX-XX-X-XXX-X**

BY: BRYANT 04/24/1991 SHEET 3 OF 3

## Looking for pricing, stock, or lifecycle information?

Click below to explore more details on WIN SOURCE:

 [View TSM-105-01-L-DV-P on WIN SOURCE](#)

 [Samtec Inc. Information](#)

## Optimize Your Supply Chain with WIN SOURCE Solutions

-  Global Sourcing Solution
-  Obsolete Management
-  Cost Control Management
-  Shortage Management
-  Alternative Solution
-  Excess Inventory Management