



SILERGY

SY20731

Low Dropout 1A LDO Regulator

General Description

The SY20731 is a low-dropout voltage regulator with an input voltage range of 1.6V to 5.5V, and capable of sourcing up to 1A to a load. Protection features like fold-back current limit and overtemperature protection enable the use of the part in demanding applications. The output voltage can be configured using a resistor network.

The SY20731 is available in an industry standard DFN 3mmx3mm-6pin package, which offers low thermal resistance.

Features

- Input Voltage Range: 1.6-5.5V
- Up to 1A Output Current
- Output Voltage Accuracy: $\pm 3\%$
- Low Dropout Voltage:
 - Typ. 0.32V at $I_{OUT}=1A$, $V_{OUT}=1.5V$
 - Typ. 0.18V at $I_{OUT}=1A$, $V_{OUT}=2.8V$
- Current Limiting Protection
- Thermal Shutdown Protection
- Quiescent Current: 60 μ A
- Output Auto-discharge Function
- Over Temperature Protection
- RoHS Compliant and Halogen Free
- Compact Package: DFN3x3-6

Applications

- Portable Communication Equipment
- Hand-Held Instruments, Notebook PCs
- Camcorders and Cameras

Typical Applications

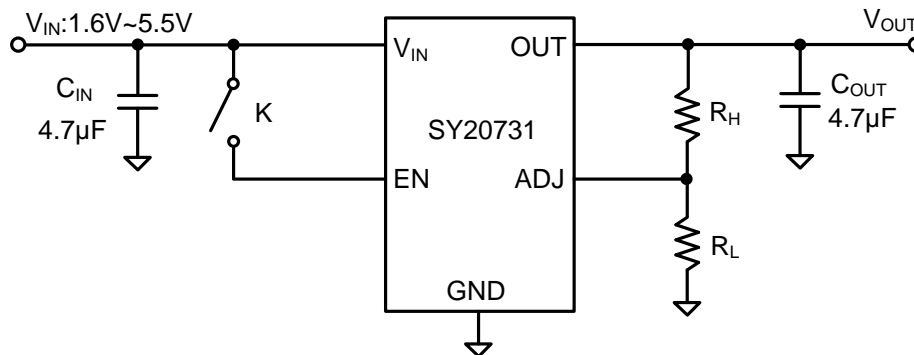

Figure 1. Schematic diagram

Ordering Information

Ordering Part Number	Package Type	Top Mark
SY20731DSC	DFN3x3-6 RoHS Compliant and Halogen Free	RBxyz

x = year code, y = week code, z = lot number code

Pinout (top view)

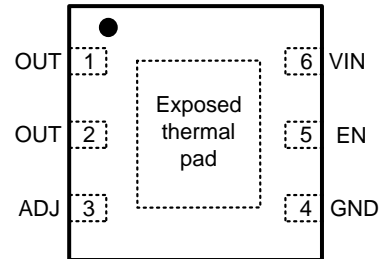

Pin Description

Pin No	Pin Name	Pin Description
OUT	1, 2	Output pin. Decouple this pin to the GND pin with at least a 4.7μF ceramic capacitor.
ADJ	3	Output voltage programming pin. Connect this pin to the center point of the output resistor divider (as shown in Figure 1) to program the output voltage: $V_{OUT}=1.0V \times (1+R_H/R_L)$.
GND	4	Ground pin.
EN	5	Enable control pin. A 5MΩ pull-down resistor is integrated.
VIN	6	Input pin. Decouple this pin to the GND pin with at least a 4.7μF ceramic capacitor.

Block Diagram

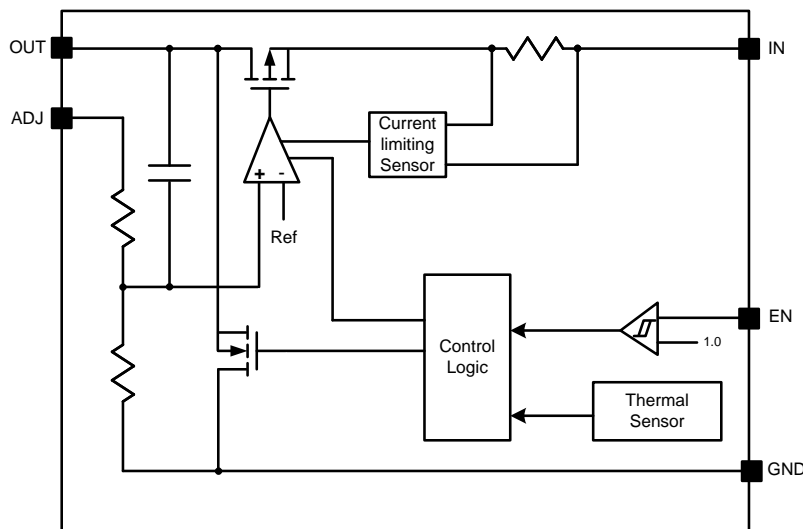

Figure 2. Block diagram

Absolute Maximum Ratings

Parameter (Note 1)	Min	Max	Unit
IN, EN	-0.3	6	V
Lead Temperature (Soldering, 10s)		260	°C
Junction Temperature, Operating	-40	150	
Storage Temperature	-65	150	

Thermal Information

Parameter (Note 2)	Typ	Unit
θ_{JA} Junction-to-Ambient Thermal Resistance	50	°C/W
θ_{JC} Junction-to-Case Thermal Resistance	15	
P_D Power Dissipation $T_A = 25^\circ\text{C}$	2	W

Recommended Operating Conditions

Parameter (Note 3)	Min	Max	Unit
IN	1.6	5.5	V
OUT	1	V_{IN}	
Junction Temperature, Operating	-40	125	°C
Ambient Temperature	-40	85	

Note 1: Stresses beyond the “Absolute Maximum Ratings” may cause permanent damage to the device. These are stress ratings only. Functional operation of the device at these or any other conditions beyond those indicated in the operational sections of the specification is not implied. Exposure to absolute maximum rating conditions for extended periods may affect device reliability.

Note 2: θ_{JA} is measured in the natural convection at $T_A = 25^\circ\text{C}$ on Silergy test board.

Note 3: The device is not guaranteed to function outside its operating conditions.

Electrical Characteristics

($V_{IN} = 5\text{V}$, $C_{IN} = 4.7\mu\text{F}$, $C_{OUT} = 4.7\mu\text{F}$, $T_A = 25^\circ\text{C}$ unless otherwise specified)

Parameter	Symbol	Test Conditions	Min	Typ.	Max	Unit
Input Voltage Range	V_{IN}		1.6		5.5	V
Supply Current	I_{SS}	$V_{EN} = V_{IN} = 2\text{V}$, $V_{OUT} = V_{ADJ}$, $I_{OUT} = 0\text{A}$		60	100	μA
Shutdown Current	I_{SD}	$V_{IN} = 6.0\text{V}$, $V_{EN} = 0$		0.1	1	μA
Output Voltage Accuracy	ΔV_{OUT}	$V_{OUT} = V_{ADJ}$, $V_{IN} = 2.0\text{V}$, $I_{OUT} = 100\text{mA}$	0.970		1.030	V
Output Voltage Range			1.0		V_{IN}	V
Current Limit	I_{LIM}		1.0			A
Load Regulation	$\Delta V_{OUT} / \Delta I_{OUT}$	$V_{OUT} = V_{ADJ}$, $V_{IN} = 2.0\text{V}$ $1\text{mA} \leq I_{OUT} \leq 1\text{A}$		-3		mV/A
Line Regulation	$\Delta V_{OUT} / \Delta V_{IN}$	$V_{OUT} = V_{ADJ}$, $I_{OUT} = 100\text{mA}$ $2.0 \leq V_{IN} \leq 5.5\text{V}$		0.05	0.2	%/V
EN Pull-down Resistance	R_{EN}			5		$\text{M}\Omega$
Ripple Rejection	RR	$f = 1\text{kHz}$, Ripple 0.5V_{P-P} $V_{OUT} = V_{ADJ}$, $V_{IN} = 2.5\text{V}$, $I_{OUT} = 100\text{mA}$		-60		dB



Parameter	Symbol	Test Conditions	Min	Typ.	Max	Unit
Output Voltage Temperature Coefficient	$\Delta V_{OUT}/\Delta T$	$I_{OUT}=100mA$ $-40^{\circ}C \leq T \leq 85^{\circ}C$		± 100		ppm/ $^{\circ}C$
Short Current Limit	I_{SHORT}	$V_{OUT}=0V$		250		mA
Discharge Resistor	R_{DISCHG}			100		Ω
EN Rising Threshold	V_{ENH}		1.0			V
EN Falling Threshold	V_{ENL}				0.4	V
Thermal Shutdown Temperature	T_{SD}			150		$^{\circ}C$
Thermal Shutdown Hysteresis	T_{HYS}			20		$^{\circ}C$
Dropout Voltage	V_{DROP}	Refer to following table				

Dropout Voltage by output Voltage

$T_A = 25^{\circ}C$

Output Voltage(V) V_{OUT}	Dropout Voltage V_{DROP} (V)		
	$I=300mA$		$I=1A$
	Typ.	Max	Typ
$1.0V \leq V_{OUT} < 1.5V$	0.18	0.32	0.50
$1.5V \leq V_{OUT} < 2.6V$	0.10	0.15	0.28
$2.6V \leq V_{OUT}$	0.05	0.10	0.18

Typical Operating Characteristics

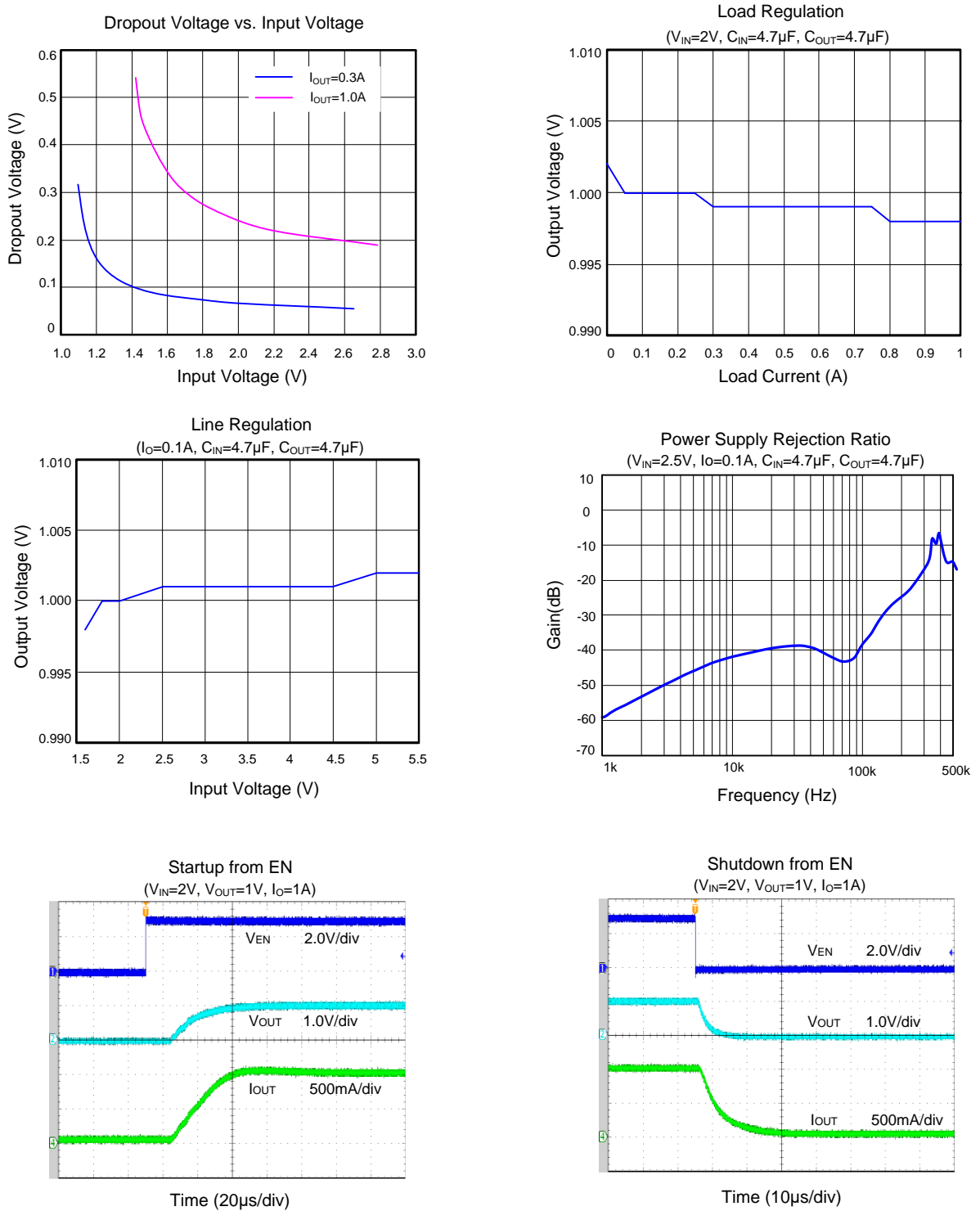

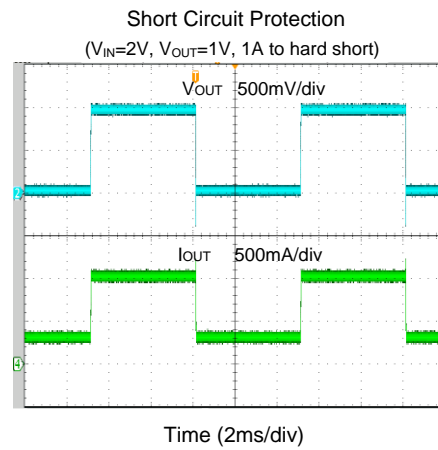
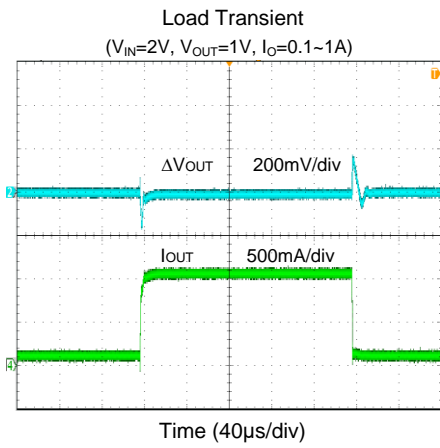

Application Information

The SY20731 is a low-dropout voltage regulator capable of sourcing up to 1A. It provides programmable output voltage with $\pm 3\%$ accuracy

Input Capacitor C_{IN}:

A 4.7 μ F decoupling capacitor is recommended between input pin and ground pin. A typical X5R or better grade ceramic capacitor with 6V rating is recommended for most applications. Place the input and output capacitors as close as practical to the input and output pins to ensure stable operation.

Output Capacitor C_{OUT}:

The SY20731 is designed to operate using low equivalent series resistance (ESR) ceramic output capacitors. This forms a zero to provide phase lead which is required for loop stability. A 4.7 μ F capacitor with 10m Ω to 50m Ω ESR range can be used in this application. Higher capacitance values help to improve transient response.

Output Voltage Setting:

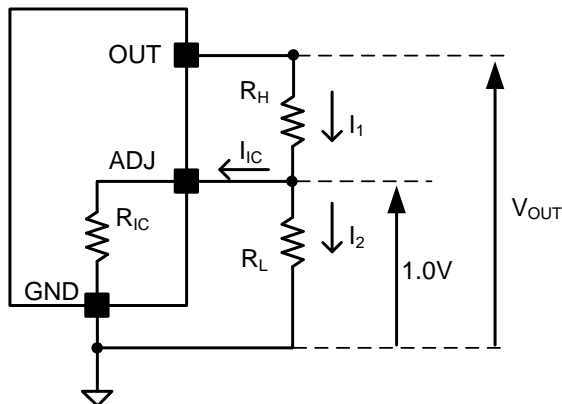

The output voltage can be adjusted from 1.0V to $V_{IN} - V_{DROP}$ by using a resistor divider. The output voltage can be calculated using the following equations:

$$V_{OUT} = 1.0 + R_H (I_{IC} + 1.0 / R_L)$$

$$V_{OUT} = 1.0 (1 + R_H / R_L) + R_H \times I_{IC}$$

When choosing $R_L \ll R_{IC}$ (1.45M Ω) the term $R_H \times I_{IC}$ becomes negligible and the output voltage can be estimated using the simplified formula:

$$V_{OUT} = 1.0 (1 + R_H / R_L), (R_L \ll R_{IC})$$

Dropout Voltage:

The dropout voltage is determined by the $R_{DS(ON)}$ of the power MOSFET. The SY20731 features a low dropout voltage due to its extra low $R_{DS(ON)}$, which determines the lowest usable supply voltage.

$$V_{DROPOUT} = V_{IN} - V_{OUT} = R_{DS(ON)} \times I_{OUT}$$

Current Limit:

The internal current-limit circuit is used to protect the LDO against transient high-load current faults. The device is configured to operate with a minimum current limit of 1A.

Short-circuit Protection

The current through the device increases very rapidly during a short circuit event. When a short circuit is detected by comparing the current through the device with the current limit threshold, the current is reduced to approximately 0.25A. Operating in current limit can trigger the integrated thermal shutdown protection circuit. The output turns on and off when thermal shutdown is reached until power dissipation is reduced.

Thermal Considerations:

The SY20731 can source a current of up to 1A over the full operating junction temperature range. However, the maximum output current must be derated at higher ambient temperature to limit junction temperature to a maximum of 125 $^{\circ}$ C. The junction temperature must be within the operating range specified under all operating conditions. The LDO power dissipation depends on the input-to-output voltage difference and load current. The dissipated power, P_D , can be calculated using the following equation:

$$P_D = (V_{IN} - V_{OUT}) \times I_{OUT} + V_{IN} \times I_{GND}$$

The operating junction temperature can be estimated using the following formula:

$$P_{D(MAX)} = (T_{J(MAX)} - T_A) / \theta_{JA}$$

Where $T_{J(MAX)}$ is the maximum junction temperature of die (125 $^{\circ}$ C) and T_A is the maximum ambient temperature.

Layout Design:

Good board layout practices must be used for stable operation, and a large PCB copper area can improve the thermal performance. The input and output capacitors must be directly connected to the input, the output, and the ground pins of the device using traces which have no other currents flowing through them. The feed back loop formed by R_L , R_H and the trace connecting to the ADJ pin and the OUT must be minimized.

Place C_{IN} and C_{OUT} near the device with short traces to the V_{IN} , V_{OUT} , and ground pins. The regulator ground pin should be connected to the external circuit ground so that the regulator and its capacitors have a “single point ground”.

Below is the recommended PCB Layout diagram:

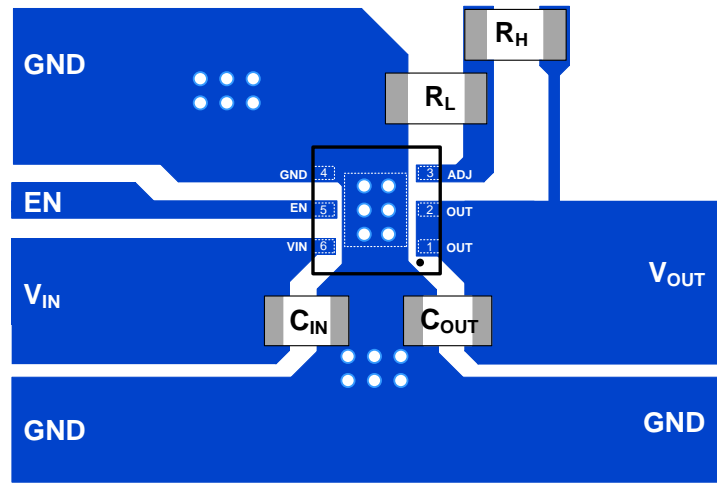
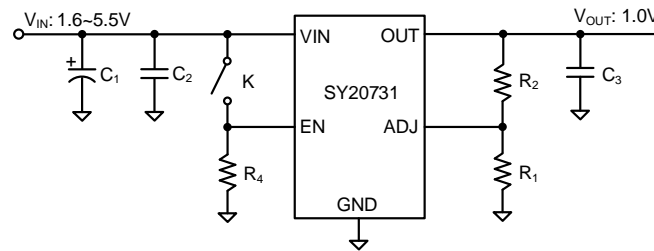

Figure3. PCB Layout Suggestion

Application Schematic ($V_{OUT} = 1.0V$)



BOM List

Reference Designator	Description	Part Number	Manufacturer
C ₁	100 μ F/16V (electrolytic capacitor)		
C ₂	4.7 μ F/6.3V, 0603, X5R	C1005X5R1A475M	TDK
C ₃	4.7 μ F/6.3V, 0603, X5R	C1005X5R1A475M	TDK
R ₁	OPEN		
R ₂	SHORT		
R ₄	1M Ω , 0603		

DFN3x3-6 Package Outline Drawing

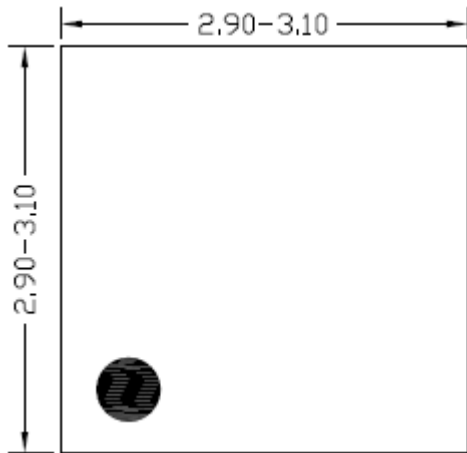

Top View

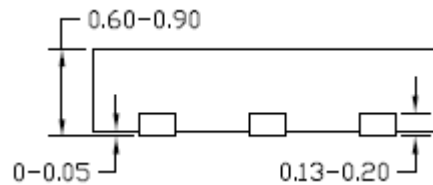

Side View

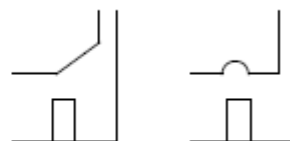
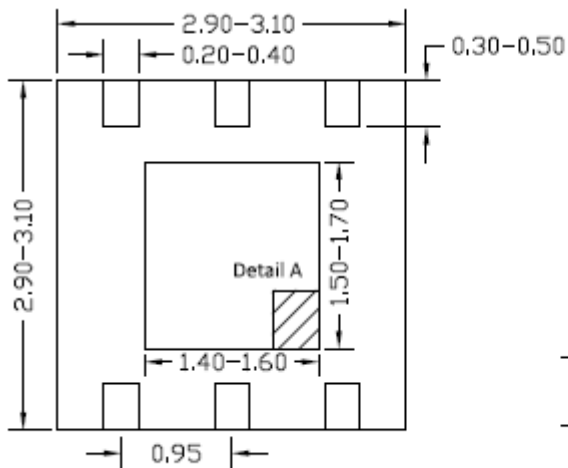

Detail A
Pin1 Identifier: two options

Bottom View

Notes: All dimension in millimeter and exclude mold flash & metal burr

Taping & Reel Specification

1. DFN3x3 taping orientation

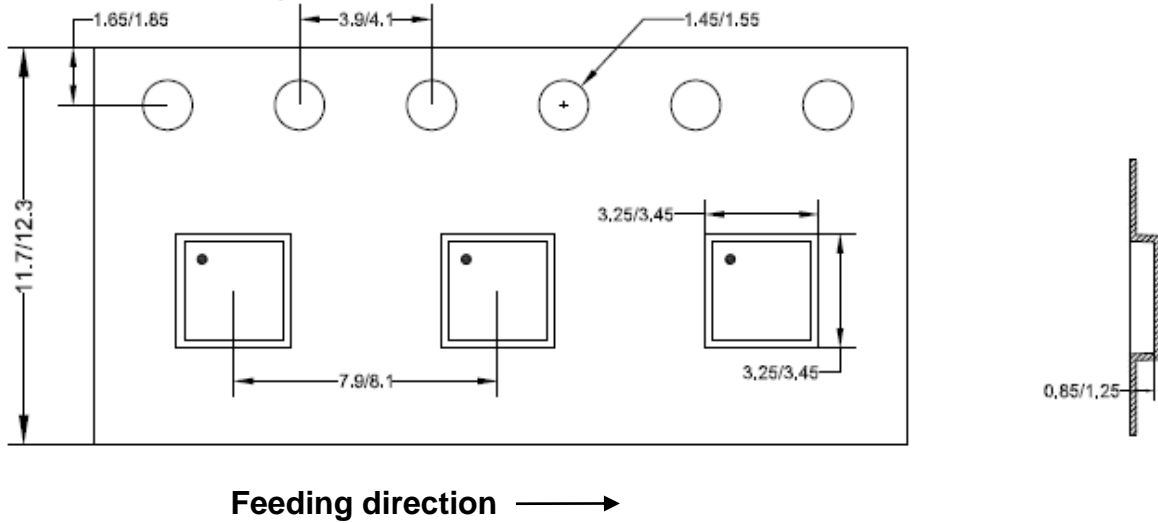

2. Carrier Tape & Reel specification for packages

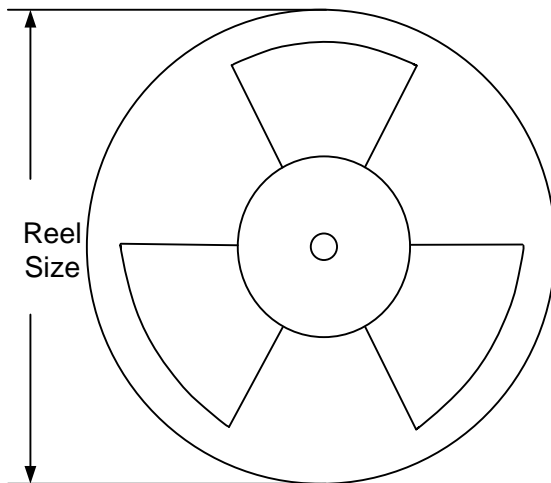

Package type	Tape width (mm)	Pocket pitch(mm)	Reel size (Inch)	Trailer length(mm)	Leader length (mm)	Qty per reel
DFN3x3	12	8	13"	400	400	5000

3. Others: NA



IMPORTANT NOTICE

- 1. Right to make changes.** Silergy and its subsidiaries (hereafter Silergy) reserve the right to change any information published in this document, including but not limited to circuitry, specification and/or product design, manufacturing or descriptions, at any time and without notice. This document supersedes and replaces all information supplied prior to the publication hereof. Buyers should obtain the latest relevant information before placing orders and should verify that such information is current and complete. All semiconductor products are sold subject to Silergy's standard terms and conditions of sale.
- 2. Applications.** Application examples that are described herein for any of these products are for illustrative purposes only. Silergy makes no representation or warranty that such applications will be suitable for the specified use without further testing or modification. Buyers are responsible for the design and operation of their applications and products using Silergy products. Silergy or its subsidiaries assume no liability for any application assistance or designs of customer products. It is customer's sole responsibility to determine whether the Silergy product is suitable and fit for the customer's applications and products planned. To minimize the risks associated with customer's products and applications, customer should provide adequate design and operating safeguards. Customer represents and agrees that it has all the necessary expertise to create and implement safeguards which anticipate dangerous consequences of failures, monitor failures and their consequences, lessen the likelihood of failures that might cause harm and take appropriate remedial actions. Silergy assumes no liability related to any default, damage, costs or problem in the customer's applications or products, or the application or use by customer's third-party buyers. Customer will fully indemnify Silergy, its subsidiaries, and their representatives against any damages arising out of the use of any Silergy components in safety-critical applications. It is also buyers' sole responsibility to warrant and guarantee that any intellectual property rights of a third party are not infringed upon when integrating Silergy products into any application. Silergy assumes no responsibility for any said applications or for any use of any circuitry other than circuitry entirely embodied in a Silergy product.
- 3. Limited warranty and liability.** Information furnished by Silergy in this document is believed to be accurate and reliable. However, Silergy makes no representation or warranty, expressed or implied, as to the accuracy or completeness of such information and shall have no liability for the consequences of use of such information. In no event shall Silergy be liable for any indirect, incidental, punitive, special or consequential damages, including but not limited to lost profits, lost savings, business interruption, costs related to the removal or replacement of any products or rework charges, whether or not such damages are based on tort or negligence, warranty, breach of contract or any other legal theory. Notwithstanding any damages that customer might incur for any reason whatsoever, Silergy' aggregate and cumulative liability towards customer for the products described herein shall be limited in accordance with the Standard Terms and Conditions of Sale of Silergy.
- 4. Suitability for use.** Customer acknowledges and agrees that it is solely responsible for compliance with all legal, regulatory and safety-related requirements concerning its products, and any use of Silergy components in its applications, notwithstanding any applications-related information or support that may be provided by Silergy. Silergy products are not designed, authorized or warranted to be suitable for use in life support, life-critical or safety-critical systems or equipment, nor in applications where failure or malfunction of a Silergy product can reasonably be expected to result in personal injury, death or severe property or environmental damage. Silergy assumes no liability for inclusion and/or use of Silergy products in such equipment or applications and therefore such inclusion and/or use is at the customer's own risk.
- 5. Terms and conditions of commercial sale.** Silergy products are sold subject to the standard terms and conditions of commercial sale, as published at <http://www.silergy.com/stdterms>, unless otherwise agreed in a valid written individual agreement specifically agreed to in writing by an authorized officer of Silergy. In case an individual agreement is concluded only the terms and conditions of the respective agreement shall apply. Silergy hereby expressly objects to and denies the application of any customer's general terms and conditions with regard to the purchase of Silergy products by the customer.
- 6. No offer to sell or license.** Nothing in this document may be interpreted or construed as an offer to sell products that is open for acceptance or the grant, conveyance or implication of any license under any copyrights, patents or other industrial or intellectual property rights. Silergy makes no representation or warranty that any license, either express or implied, is granted under any patent right, copyright, mask work right, or other intellectual property right. Information published by Silergy regarding third-party products or services does not constitute a license to use such products or services or a warranty or endorsement thereof. Use of such information may require a license from a third party under the patents or other intellectual property of the third party, or a license from Silergy under the patents or other intellectual property of Silergy.

For more information, please visit: www.silergy.com

Looking for pricing, stock, or lifecycle information?

Click below to explore more details on WIN SOURCE:

 [View SY6301DSC on WIN SOURCE](#)

 [Silergy Corp](#) Information

Optimize Your Supply Chain with WIN SOURCE Solutions

-  Global Sourcing Solution
-  Obsolete Management
-  Cost Control Management
-  Shortage Management
-  Alternative Solution
-  Excess Inventory Management