



THE DATASHEET OF FCH35N60



Data Sheet

Description

The HCPL-4562 and HCNW4562 optocouplers provide wide-bandwidth isolation for analog signals. They are ideal for video isolation when combined with their application circuit (Figure 4). High linearity and low phase shift are achieved through an AlGaAs LED combined with a high-speed detector. These single-channel optocouplers are available in 8-pin DIP and wide-body package configurations.

Functional Diagram

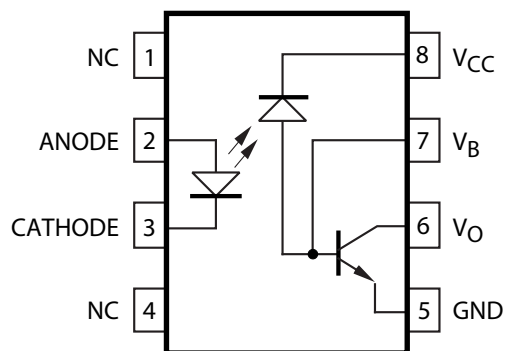

Applications

- Video isolation for the following standards/formats: NTSC, PAL, SECAM, S-VHS, ANALOG RGB
- Low drive current feedback element in switching power supplies (for ISDN networks, as an example)
- A/D converter signal isolation
- Analog signal ground isolation
- High-voltage insulation

Features

- Wide bandwidth^[1]:
 - 17 MHz (HCPL-4562)
 - 9 MHz (HCNW4562)
- High voltage gain^[1]:
 - 2.0 (HCPL-4562)
 - 3.0 (HCNW4562)
- Low GV temperature coefficient: $-0.3\%/^{\circ}\text{C}$
- Highly linear at low drive currents
- High-speed AlGaAs emitter
- Safety approval:
 - UL Recognized: $3750V_{\text{RMS}}$ for 1 minute ($5000V_{\text{RMS}}$ for 1 minute for HCPL-4562#020 and HCNW4562) per UL 1577
 - CSA Approved
 - IEC/EN/DIN EN 60747-5-5 Approved: $V_{\text{IORM}} = 1414V_{\text{peak}}$ for HCNW4562
- Available in 8-pin DIP and wide-body packages

CAUTION

It is advised that normal static precautions be taken in the handling and assembly of this component to prevent damage and/or degradation which may be induced by ESD. The components featured in this data sheet are not to be used in military or aerospace applications or environments.

Selection Guide

Single-Channel Packages	
8-Pin DIP (300 mil)	Wide-Body (400 mil)
HCPL-4562	HCNW4562

Ordering Information

HCPL-4562 is UL Recognized with 3750V_{RMS} for 1 minute per UL1577 unless otherwise specified. HCNW4562 is UL Recognized with 5000V_{RMS} for 1 minute per UL1577.

Part Number	Option		Package	Surface Mount	Gull Wing	Tape and Reel	UL 5000V _{RMS} /1 Minute Rating	IEC/EN/DIN EN 60747-5-5	Quantity
	RoHS Compliant	Non-RoHS Compliant							
HCPL-4562	-000E	no option	300 mil DIP-8						50 per tube
	-300E	#300		X	X				50 per tube
	-500E	#500		X	X	X			1000 per reel
	-020E	#020					X		50 per tube
	-320E	#320		X	X		X		50 per tube
	-520E	#520		X	X	X	X		1000 per reel
	-060E	#060						χ ^a	50 per tube
HCNW-4562	-000E	no option	400 mil wide-body DIP-8				X	χ ^b	42 per tube
	-300E	#300		X	X		X	χ ^b	42 per tube
	-500E	#500		X	X	X	X	χ ^b	750 per reel

a. IEC/EN/DIN EN 60747-5-5 V_{IORM} = 630V_{peak} Safety Approval.

b. IEC/EN/DIN EN 60747-5-5 V_{IORM} = 1414V_{peak} Safety Approval.

To order, choose a part number from the part number column and combine with the desired option from the option column to form an order entry.

Example 1:

HCPL-4562-520E to order product of Gull Wing Surface Mount package in Tape and Reel packaging with UL 5000V_{RMS}/1 minute rating and RoHS compliant.

Example 2:

HCNW4562 to order product of 8-Pin Wide-body DIP package in Tube packaging with IEC/EN/DIN EN 60747-5-5 V_{IORM} = 1414V_{peak} Safety Approval and UL 5000V_{RMS}/1 minute rating and non RoHS compliant.

Option data sheets are available. Contact your Broadcom sales representative or authorized distributor for information.

Remarks: The notation '#XXX' is used for existing products, while (new) products launched since July 15, 2001 and RoHS compliant will use '-XXxE'.

Package Outline Drawings

8-Pin DIP Package (HCPL-4562)

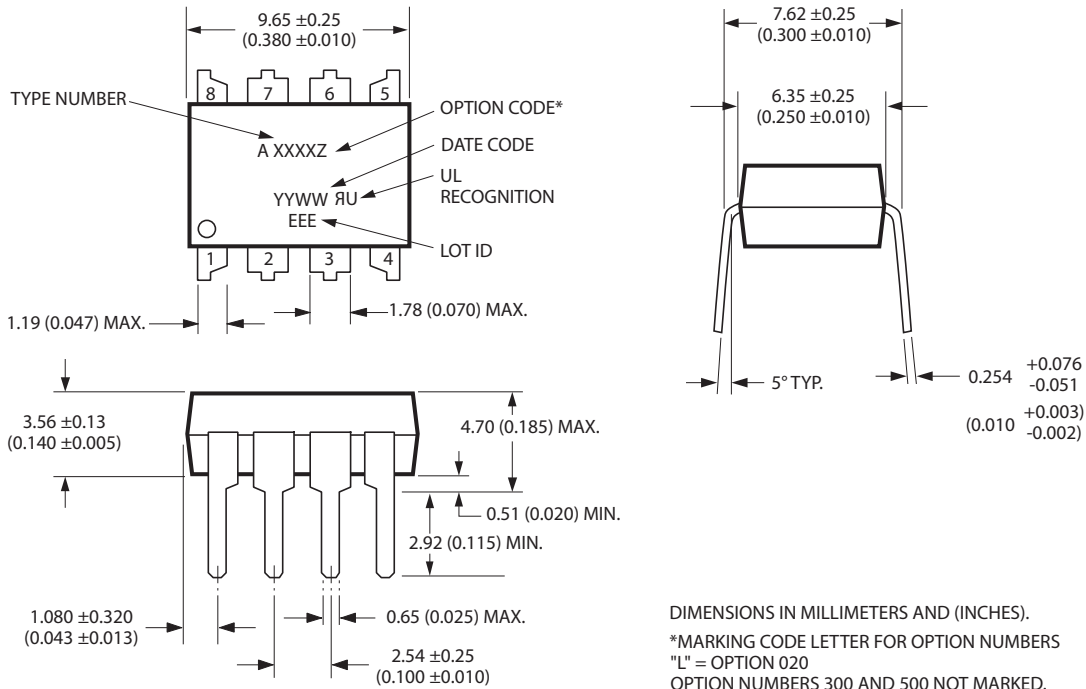

NOTE: FLOATING LEAD PROTRUSION IS 0.25 mm (10 mils) MAX.

8-Pin DIP Package with Gull Wing Surface Mount Option 300 (HCPL-4562)

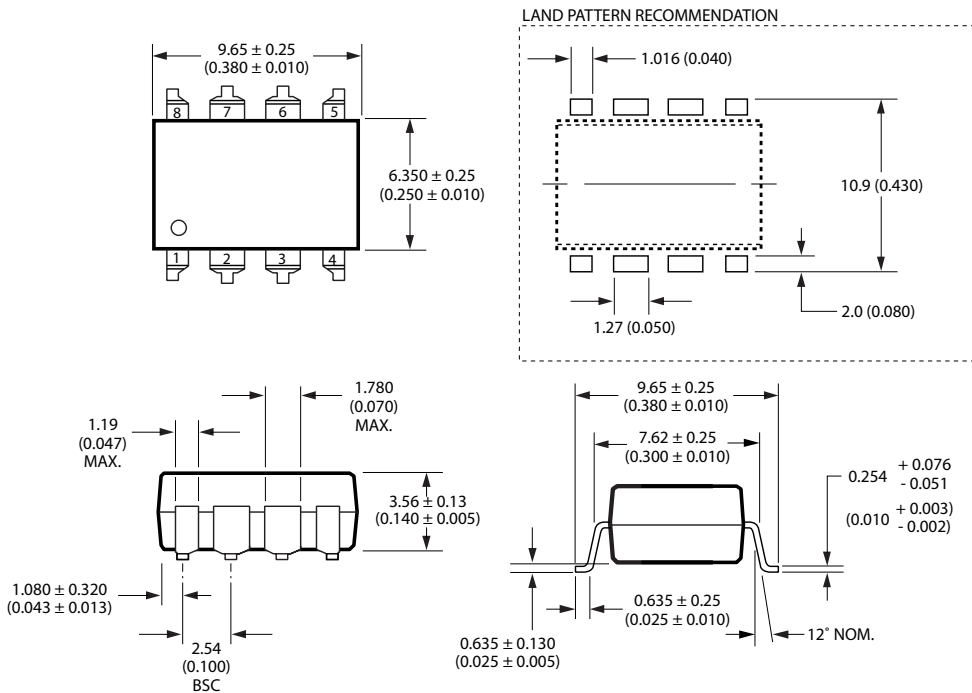

NOTE: FLOATING LEAD PROTRUSION IS 0.25 mm (10 mils) MAX.

8-Pin Wide-Body DIP Package (HCNW4562)

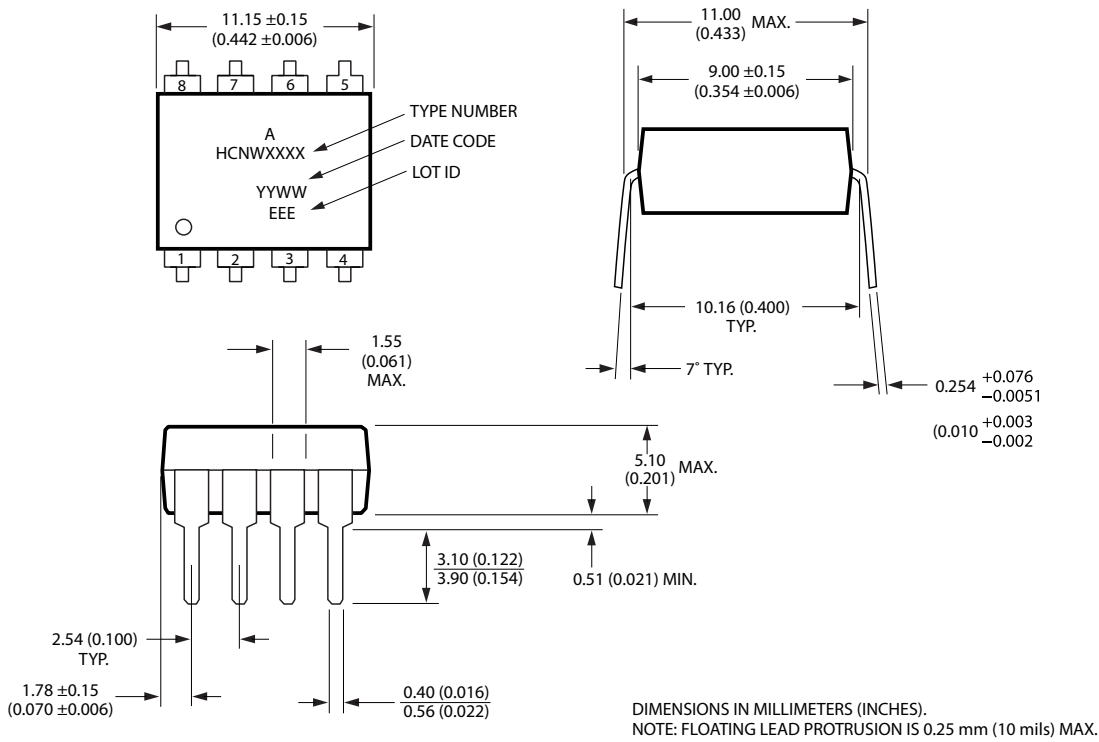

8-Pin Wide-Body DIP Package with Gull Wing Surface Mount Option 300 (HCNW4562)

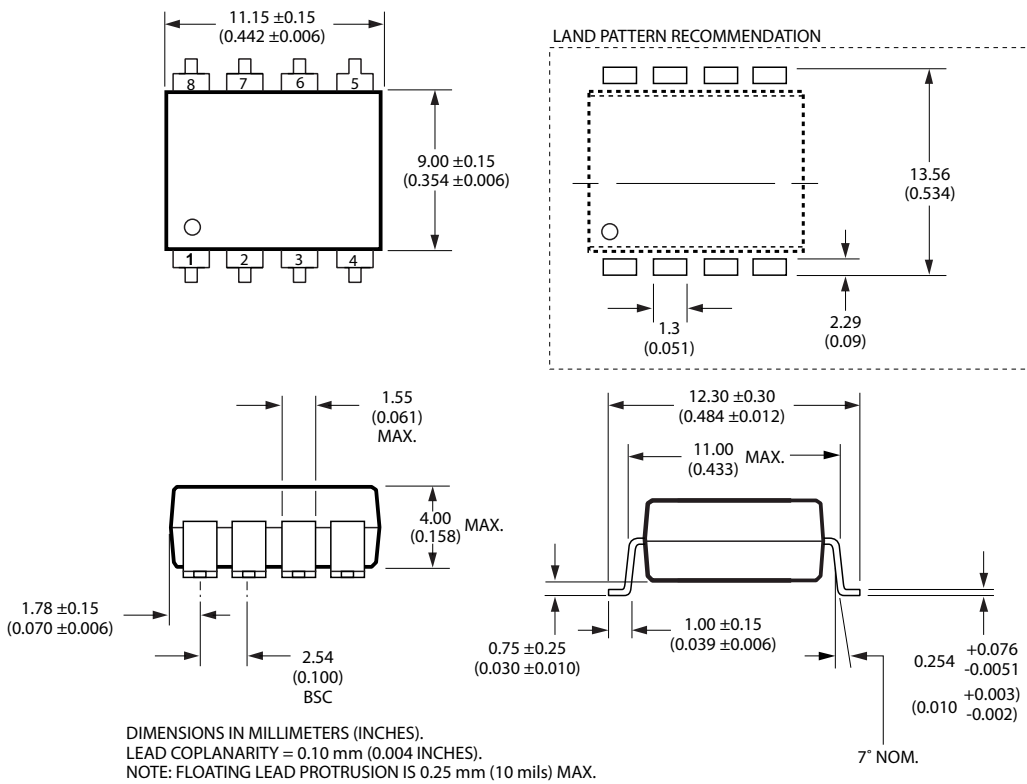

Schematic

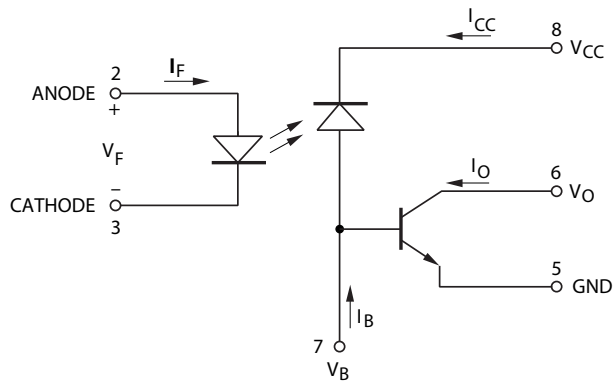

Reflow Soldering Profile

The recommended reflow soldering conditions are per JEDEC Standard J-STD-020 (latest revision). Non-halide flux should be used.

Regulatory Information

The devices contained in this data sheet have been approved by the following organizations:

- IEC/EN/DIN EN 60747-5-5:
- UL: Recognized under UL 1577, Component Recognition Program, File E55361.
- CSA: Approval under CSA Component Acceptance Notice #5, File CA 88324.

Insulation and Safety Related Specifications

Parameter	Symbol	8-Pin DIP (300 mil) Value	Wide-Body (400 mil) Value	Unit	Conditions
Minimum External Air Gap (External Clearance)	L(101)	7.1	9.6	mm	Measured from input terminals to output terminals, shortest distance through air.
Minimum External Tracking (External Creepage)	L(102)	7.4	10.0	mm	Measured from input terminals to output terminals, shortest distance path along body.
Minimum Internal Plastic Gap (Internal Clearance)		0.08	1.0	mm	Through insulation distance, conductor to conductor, usually the direct distance between the photoemitter and photodetector inside the optocoupler cavity.
Minimum Internal Tracking (Internal Creepage)		N/A	4.0	mm	Measured from input terminals to output terminals, along internal cavity.
Tracking Resistance (Comparative Tracking Index)	CTI	200	200	V	DIN IEC 112/VDE 0303 Part 1
Isolation Group		IIIa	IIIa		Material Group (DIN VDE 0110, 1/89, Table 1)

Option 300: surface-mount classification is Class A in accordance with CECC 00802.

IEC/EN/DIN EN 60747-5-5 Insulation Characteristics

Description	Symbol	8-Pin DIP	Wide-Body	Unit
Installation classification per DIN VDE 0110, Table 1 for rated mains voltage 150V _{RMS} for rated mains voltage 300V _{RMS} for rated mains voltage 600V _{RMS} for rated mains voltage 1000V _{RMS}		I - IV I - IV I - III	I - IV I - IV I - IV I - III	
Climatic Classification		10/70/21	10/70/21	
Pollution Degree (DIN VDE 0110/39)		2	2	
Maximum Working Insulation Voltage	V _{IORM}	630	1414	V _{peak}
Input to Output Test Voltage, Method b ^a V _{IORM} × 1.875 = V _{PR} , 100% Production Test with tm=1 sec, Partial discharge < 5 pC	V _{PR}	1181	2651	V _{peak}
Input to Output Test Voltage, Method a* V _{IORM} × 1.6 = V _{PR} , Type and Sample Test, tm=10 sec, Partial discharge < 5 pC	V _{PR}	1008	2262	V _{peak}
Highest Allowable Overvoltage (Transient Overvoltage tini = 60 sec)	V _{IOTM}	6000	8000	V _{peak}
Safety-limiting values - maximum values allowed in the event of a failure.				
Case Temperature	T _S	175	150	°C
Input Current	I _{S, INPUT}	230	400	mA
Output Power	P _{S, OUTPUT}	600	700	mW
Insulation Resistance at T _S , V _{IO} = 500V	R _S	≥10 ⁹	≥10 ⁹	Ω

a. Refer to the front of the optocoupler section of the current catalog, under Product Safety Regulations section IEC/EN/DIN EN 60747-5-5, for a detailed description.

NOTE These optocouplers are suitable for “safe electrical isolation” only within the safety limit data. Maintenance of the safety limit data shall be ensured by means of protective circuits.

Absolute Maximum Ratings

Parameter	Symbol	Device	Min.	Max.	Unit	Note
Storage Temperature	T_S		-55	+125	°C	
Operating Temperature	T_A		-40	+85	°C	
Average Forward Input Current	$I_{F(AVG)}$	HCPL-4562		12	mA	
		HCNW4562		25		
Peak Forward Input Current	$I_{F(PEAK)}$	HCPL-4562		18.6	mA	
		HCNW4562		40		
Effective Input Current	$I_{F(EFF)}$	HCPL-4562		12.9	mA rms	
Reverse LED Input Voltage (Pins 3-2)	V_R	HCPL-4562		1.8	V	
		HCNW4562		3		
Input Power Dissipation	P_{IN}	HCNW4562		40	mW	
Average Output Current (Pin 6)	$I_{O(AVG)}$			8	mA	
Peak Output Current (Pin 6)	$I_{O(PEAK)}$			16	mA	
Emitter-Base Reverse Voltage (Pins 5-7)	V_{EBR}			5	V	
Supply Voltage (Pins 8-5)	V_{CC}		-0.3	+30	V	
Output Voltage (Pins 6-5)	V_O		-0.3	+20	V	
Base Current (Pin 7)	I_B			5	mA	
Output Power Dissipation	P_O			100	mW	2
Lead Solder Temperature 1.6 mm Below Seating Plane, 10 Seconds up to Seating Plane, 10 Seconds	T_{LS}	HCPL-4562		260	°C	
		HCNW4562		260	°C	
Reflow Temperature Profile	T_{RP}	Option 300	See Package Outline Drawings Section			

Recommended Operating Conditions

Parameter	Symbol	Device	Min.	Max.	Unit	Note
Operating Temperature	T_A	HCPL-4562	-10		°C	
Quiescent Input Current	I_{FQ}	HCPL-4562		6	mA	
		HCNW4562		10		
Peak Input Current	$I_{F(PEAK)}$	HCPL-4562		10	mA	
		HCNW4562		17		

Electrical Specifications (DC)

T_A = 25°C, I_F = 6 mA for HCPL-4562 and I_F = 10 mA for HCNW4562 (meaning Recommended IFQ) unless otherwise specified.

Parameter	Symbol	Device	Min.	Typ.	Max.	Unit	Test Conditions	Fig.	Note
Base Photo Current	I _{PB}		13	31	65	μA	I _F = 10 mA, V _{PB} ≥ 5V	2, 7, 8	
		HCPL-4562		19.2			I _F = 6 mA, V _{PB} ≥ 5V		
I _{PB} Temperature Coefficient	ΔI _{PB} /ΔT			-0.3		%/°C	2 mA < I _F < 10 mA, V _{PB} ≥ 5V	2	
I _{PB} Nonlinearity		HCPL-4562		0.25		%	2 mA < I _F < 10 mA	2, 7, 8	3
		HCNW4562		0.15			6 mA < I _F < 14 mA		
Input Forward Voltage	V _F	HCPL-4562	1.1	1.3	1.6	V	I _F = 5 mA	5, 6	
		HCNW4562	1.2	1.6	1.8		I _F = 10 mA		
Input Reverse Breakdown Voltage	BV _R	HCPL-4562	1.8	5		V	I _R = 10 μA		
		HCNW4562	3				I _R = 100 μA		
Transistor Current Gain	h _{FE}		60	160			I _C = 1 mA, V _{CE} = 1.25V		
Current Transfer Ratio	CTR	HCPL-4562		45		%	V _{CE} = 1.25V, V _{PB} ≥ 5V	11, 12, 13, 14	4
		HCNW4562		52					
DC Output Voltage	V _{OUT}	HCPL-4562		4.25		V	G _V = 2, V _{CC} = 9V	4, 25, 26	
		HCNW4562		5.0					

Small Signal Characteristics (AC)

T_A = 25°C, I_F = 6 mA for HCPL-4562 and I_F = 10 mA for HCNW4562 (i.e., Recommended I_{F0}) unless otherwise specified.

Parameter	Symbol	Device	Min.	Typ. ^a	Max.	Unit	Test Conditions	Fig.	Note
Voltage Gain	G _V (0.1 MHz)	HCPL-4562	0.8	2.0	4.2		V _{IN} = 1V _{p-p}	1	6
		HCNW4562		3.0					
G _V Temperature Coefficient	ΔG _V /ΔT			-0.3		%/°C	V _{IN} = 1V _{p-p} , f _{REF} = 0.1 MHz	1, 17, 18	
Base Photo Current Variation	ΔI _{PB} (6 MHz)	HCPL-4562		1.1	3.0	-dB	V _{IN} = 1V _{p-p} , f _{REF} = 0.1 MHz	3, 15, 16, 19, 20	
		HCNW4562		0.36					
-3 dB Frequency (I _{PB})	I _{PB} (-3 dB)	HCPL-4562	6	15		MHz	V _{IN} = 1V _{p-p} , f _{REF} = 0.1 MHz	3, 15, 16, 19, 20	7
		HCNW4562		13					
-3 dB Frequency (G _V)	G _V (-3 dB)	HCPL-4562	6	17		MHz	V _{IN} = 1V _{p-p} , f _{REF} = 0.1 MHz	1, 17, 18	7
		HCNW4562		9					
Gain Variation	ΔG _V (6 MHz)	HCPL-4562		1.1	3.0	-dB	T _A = 25°C, V _{IN} = 1V _{p-p} , f _{REF} = 0.1 MHz	1, 17, 18	
		HCNW4562		0.54			T _A = 25°C, V _{IN} = 1V _{p-p} , f _{REF} = 0.1 MHz		
		HCPL-4562		0.8			T _A = -10°C, V _{IN} = 1V _{p-p} , f _{REF} = 0.1 MHz		
		HCPL-4562		1.5			T _A = 70°C, V _{IN} = 1V _{p-p} , f _{REF} = 0.1 MHz		
	ΔG _V (10 MHz)	HCPL-4562		1.15		-dB	V _{IN} = 1V _{p-p} , f _{REF} = 0.1 MHz		
		HCNW4562		2.27					

Parameter	Symbol	Device	Min.	Typ. ^a	Max.	Unit	Test Conditions	Fig.	Note
Differential Gain at f = 3.58 MHz		HCPL-4562		±1.0		%	$I_{Fac} = 0.7 \text{ mA p-p}, I_{Fdc} = 3 \text{ mA to } 9 \text{ mA}$	3, 9, 10	8
		HCNW4562		±0.9			$I_{Fac} = 1 \text{ mA p-p}, I_{Fdc} = 7 \text{ mA to } 13 \text{ mA}$		
Differential Phase at f = 3.58 MHz		HCPL-4562		±1		°	$I_{Fac} = 0.7 \text{ mA p-p}, I_{Fdc} = 3 \text{ mA to } 9 \text{ mA}$	3, 9, 10	9
		HCNW4562		±0.6			$I_{Fac} = 1 \text{ mA p-p}, I_{Fdc} = 7 \text{ mA to } 13 \text{ mA}$		
Total Harmonic Distortion	THD	HCPL-4562		2.5		%	$V_{IN} = 1V_{p-p}, f = 3.58 \text{ MHz}, G_V = 2$	4	10
		HCNW4562		0.75					
Output Noise Voltage	V_O (noise)			950		µV rms	10 Hz to 10 MHz	1	
Isolation Mode Rejection Ratio	IMRR	HCPL-4562		122		dB	f = 120 Hz, $G_V = 2$	23, 24	11
		HCNW4562		119					

a. The Input-Output Momentary Withstand Voltage is a dielectric voltage rating that should not be interpreted as an input-output continuous voltage rating. For the continuous voltage rating refer to the VDE 0884 Insulation Related Characteristics Table (if applicable), your equipment level safety specification or Avago Application Note 1074 entitled "Optocoupler Input-Output Endurance Voltage," publication number 5963-2203E.

Notes:

- When used in the circuit of Figure 1 or Figure 4; $G_V = V_{OUT}/V_{IN}$; $I_{FQ} = 6 \text{ mA}$ (HCPL-4562), $I_{FQ} = 10 \text{ mA}$ (HCNW4562).
- Derate linearly above 70°C free-air temperature at a rate of 2.0 mW/°C (HCPL-4562).
- Maximum variation from the best fit line of I_{PB} vs. I_F expressed as a percentage of the peak-to-peak full scale output.
- Current transfer ratio (CTR) is defined as the ratio of output collector current, I_O , to the forward LED input current, I_F , times 100%.
- Device considered a two-terminal device: Pins 1, 2, 3, and 4 shorted together and Pins 5, 6, 7, and 8 shorted together.
- Flat-band, small-signal voltage gain.
- The frequency at which the gain is 3 dB below the flat-band gain.
- Differential gain is the change in the small-signal gain of the optocoupler at 3.58 MHz as the bias level is varied over a given range.
- Differential phase is the change in the small-signal phase response of the optocoupler at 3.58 MHz as the bias level is varied over a given range.
- Total harmonic distortion (THD) is defined as the square root of the sum of the square of each harmonic distortion component. The THD of the isolated video circuit is measured using a 2.6 kΩ load in series with the 50Ω input impedance of the spectrum analyzer.
- Isolation mode rejection ratio (IMRR), a measure of the optocoupler's ability to reject signals or noise that may exist between input and output terminals, is defined by $20 \log_{10} [(V_{OUT}/V_{IN})/(V_{OUT}/V_{IM})]$, where V_{IM} is the isolation mode voltage signal.
- In accordance with UL 1577, each optocoupler is proof-tested by applying an insulation test voltage $\geq 4500V_{RMS}$ for 1 second (leakage detection current limit, $I_{LO} \leq 5 \mu\text{A}$). This test is performed before the 100% Production test shown in the IEC/EN/DIN EN 60747-5-5 Insulation Related Characteristics Table, if applicable.
- In accordance with UL 1577, each optocoupler is proof tested by applying an insulation test voltage $\geq 6000V_{RMS}$ for 1 second (leakage detection current limit, $I_{LO} \leq 5 \mu\text{A}$). This test is performed before the 100% Production test shown in the IEC/EN/DIN EN 60747-5-5 Insulation Related Characteristics Table, if applicable.

Figure 1 Gain and Bandwidth Test Circuit

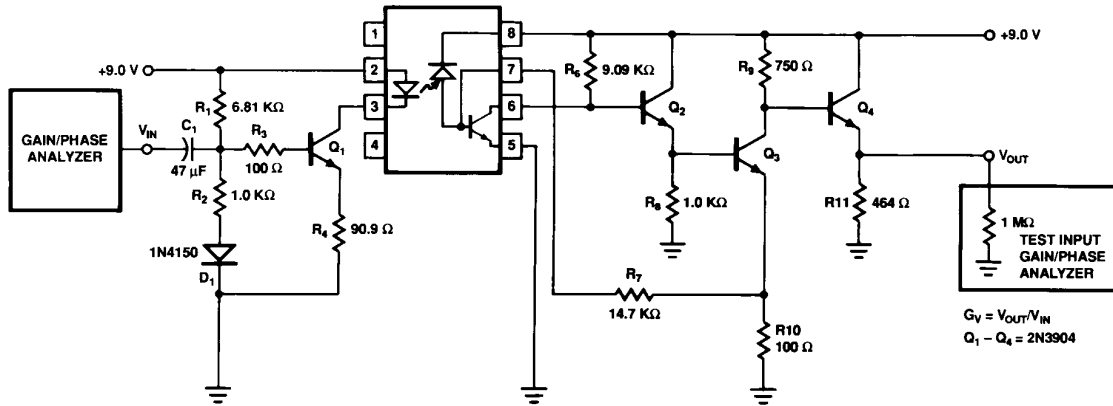

NOTE: ALL RESISTORS ARE 1% TOLERANCE

Figure 2 Base Photo Current Test Circuit

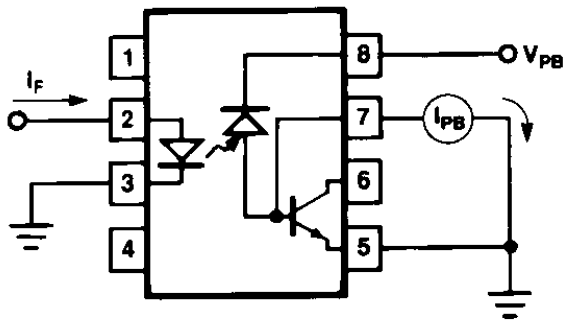
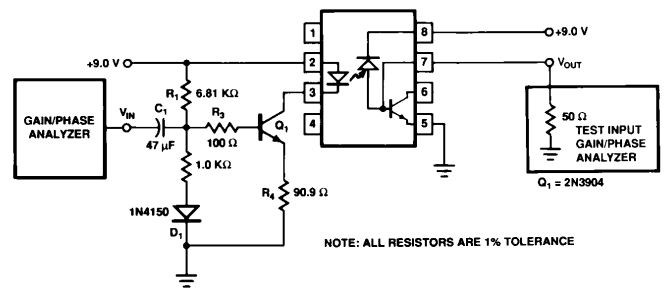

Figure 3 Base Photo Current Frequency Response Test Circuit



NOTE: ALL RESISTORS ARE 1% TOLERANCE

Figure 4 Recommended Isolated Video Interface Circuit

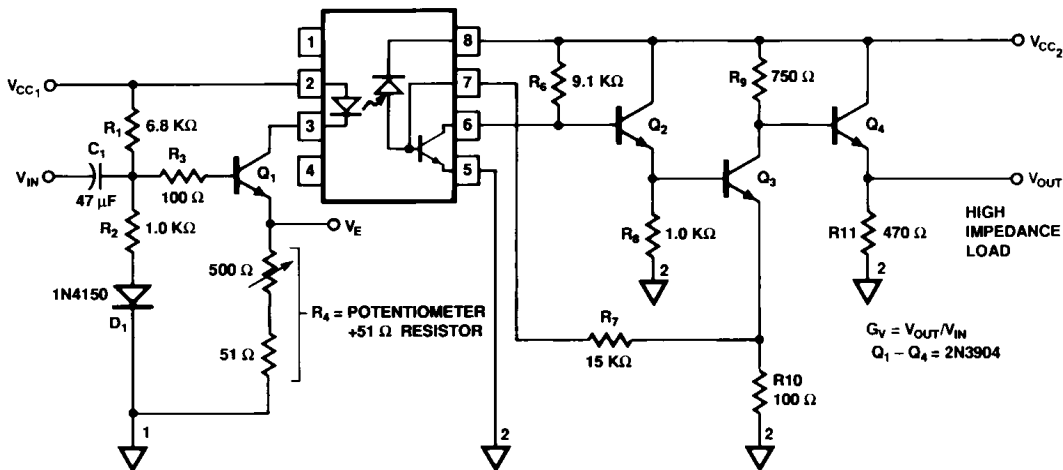

Figure 5 Input Current vs. Forward Voltage (HCPL-4562)

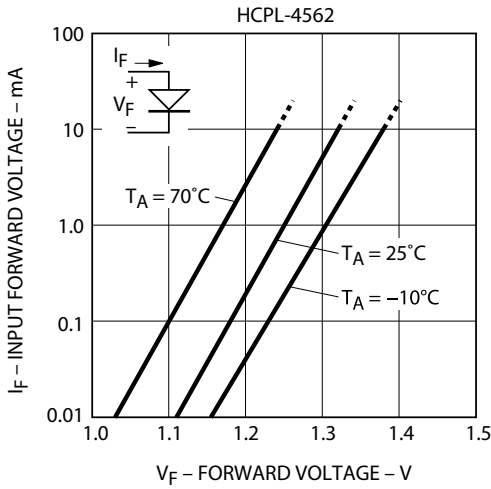

Figure 6 Input Current vs. Forward Voltage (HCNW4562)

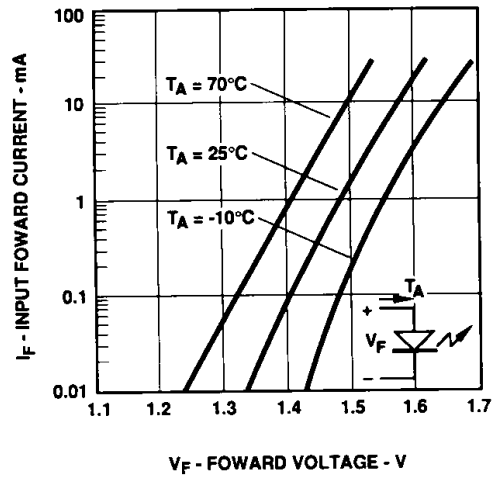

Figure 7 Base Photo Current vs. Input Current (HCPL-4562)

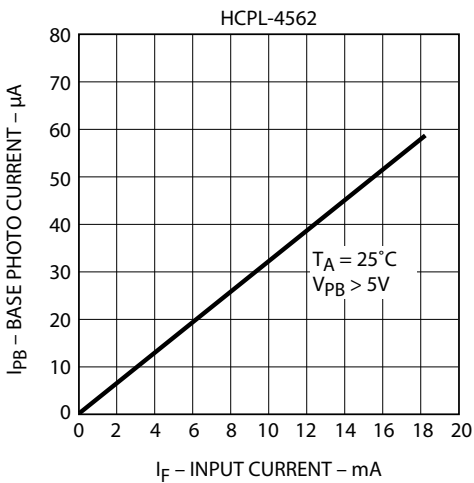

Figure 8 Base Photo Current vs. Input Current (HCNW4562)

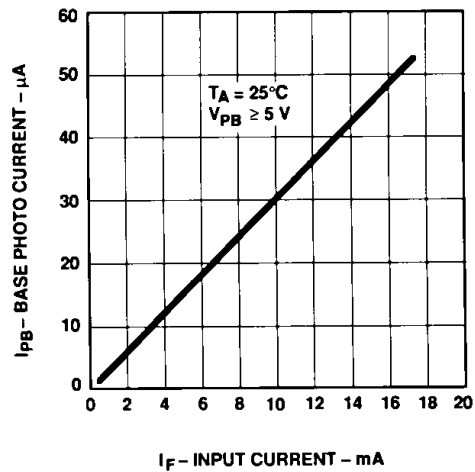

Figure 9 Small-Signal Response vs. Input Current (HCPL-4562)

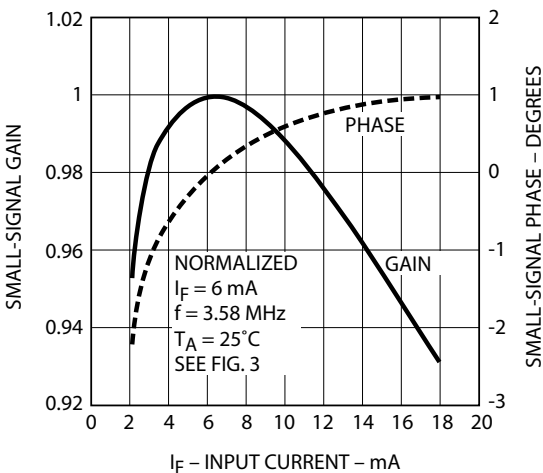

Figure 10 Small-Signal Response vs. Input Current (HCNW4562)

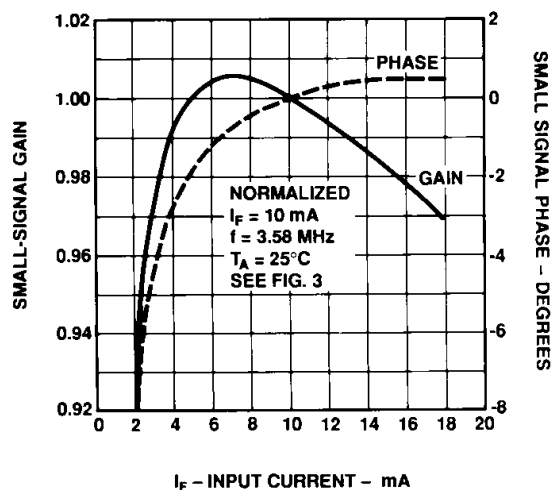

Figure 11 Current Transfer Ratio vs. Temperature (HCPL-4562)

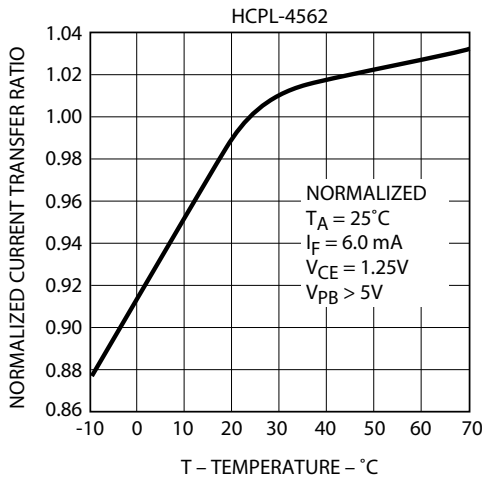

Figure 12 Current Transfer Ratio vs. Temperature (HCNW4562)

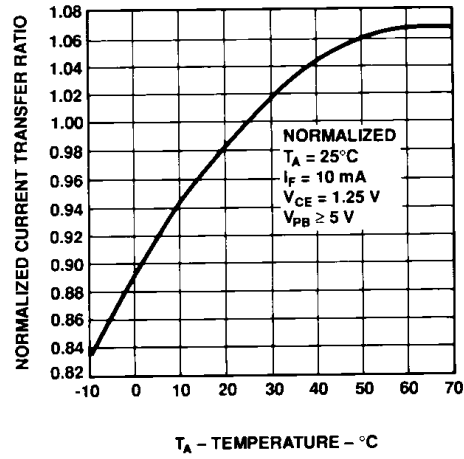

Figure 13 Current Transfer Ratio vs. Input Current (HCPL-4562)

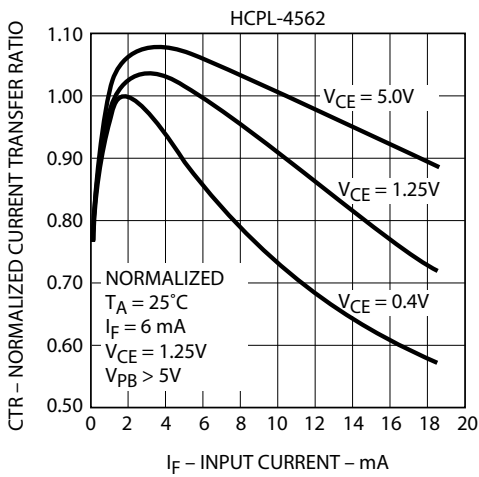

Figure 14 Current Transfer Ratio vs. Input Current (HCNW4562)

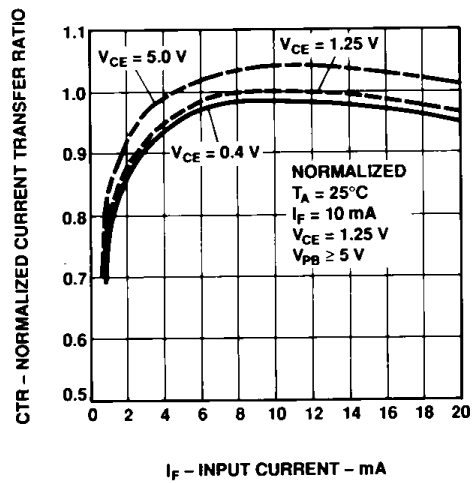

Figure 15 Base Photo Current Variation vs. Bias Conditions (HCPL-4562)

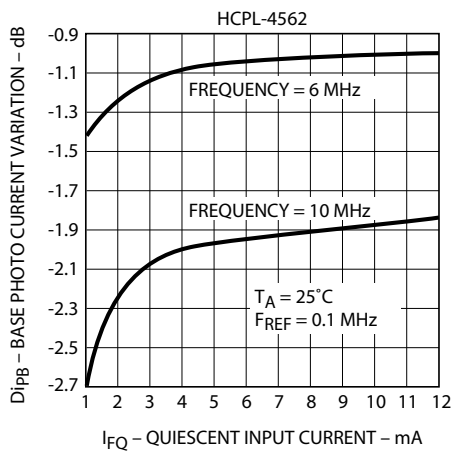

Figure 16 Base Photo Current variation vs. Bias Conditions (HCNW4562)

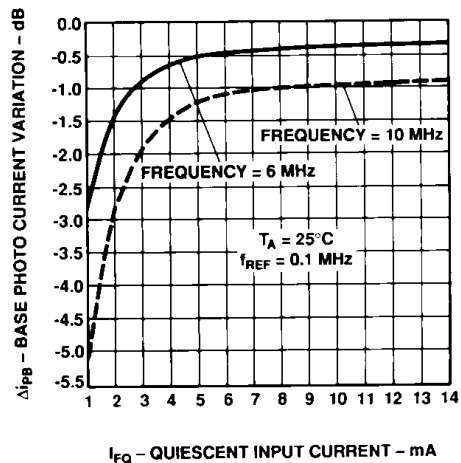

Figure 17 Normalized Voltage Gain vs. Frequency (HCPL-4562)

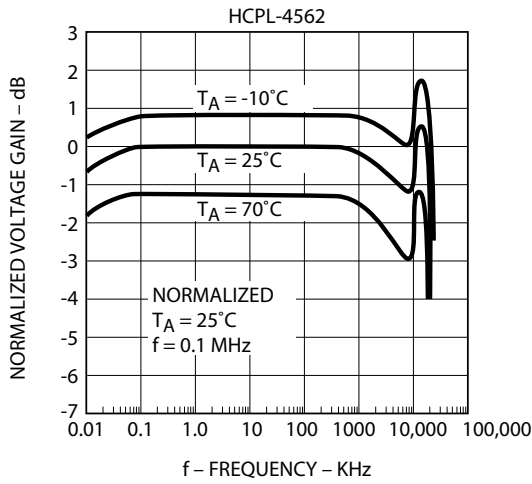

Figure 18 Normalized Voltage Gain vs. Frequency (HCNW4562)

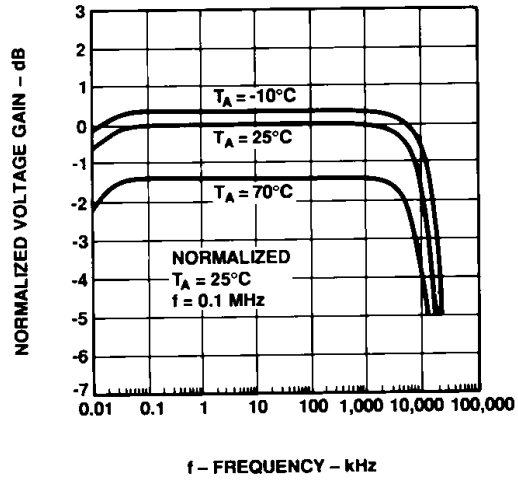

Figure 19 Normalized Base Photo Current vs. Frequency (HCPL-4562)

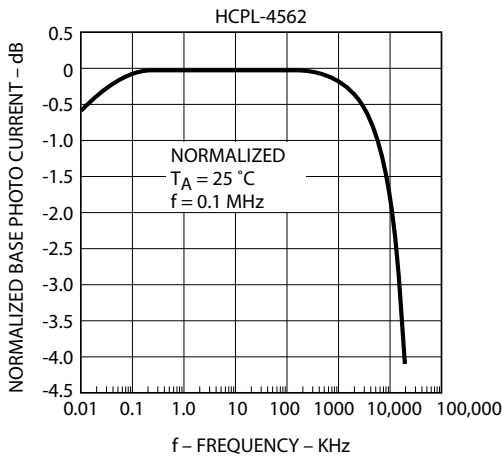

Figure 20 Normalized Base Photo Current vs. Frequency (HCNW4562)

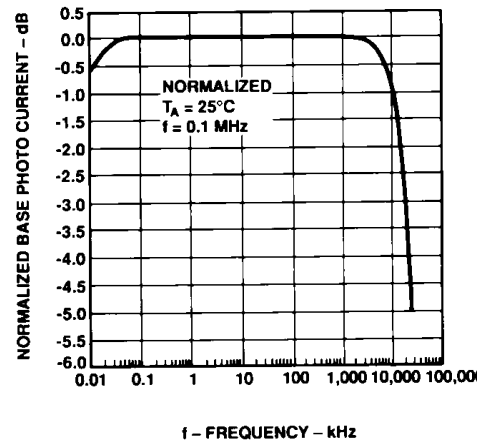

Figure 21 Phase vs. Frequency (HCPL-4562)

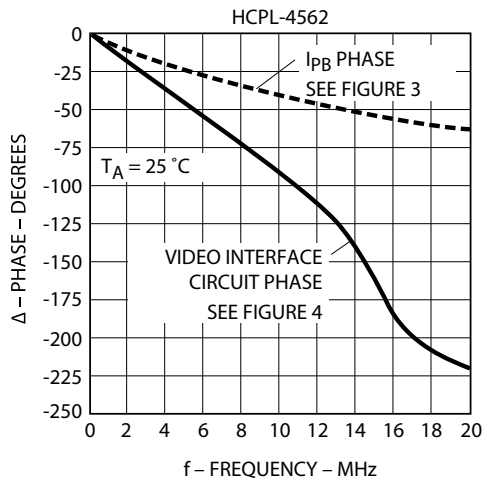

Figure 22 Phase vs. Frequency (HCNW4562)

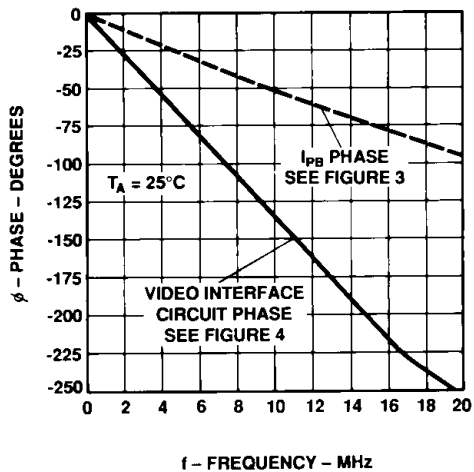

Figure 23 Isolation Mode Rejection Ratio vs. Frequency (HCPL-4562)

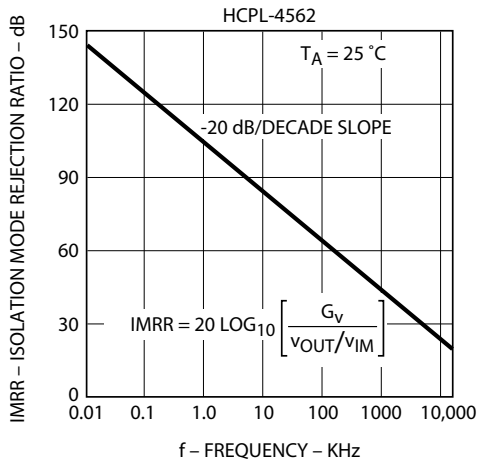

Figure 24 Isolation Mode Rejection Ratio vs. Frequency (HCNW4562)

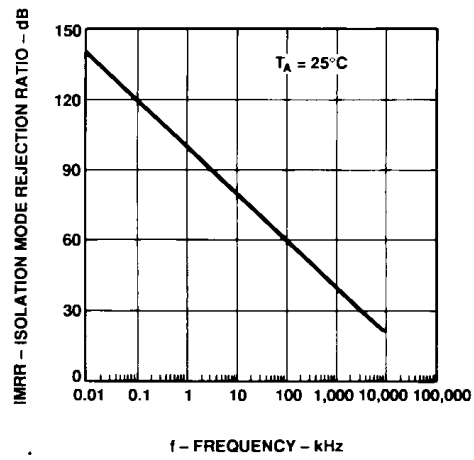

Figure 25 DC Output Voltage vs. Transistor Current Gain (HCPL-4562)

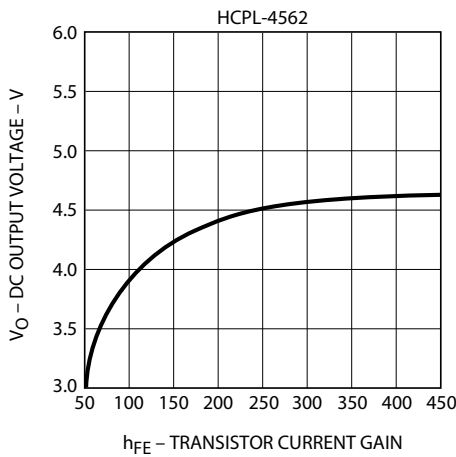

Figure 26 DC Output Voltage vs. Transistor Current Gain (HCNW4562)

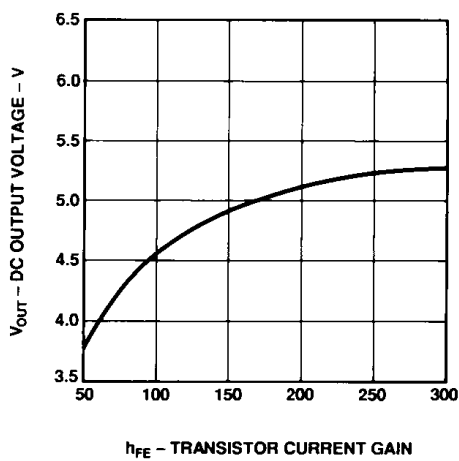

Figure 27 Output Buffer Stage for Low-Impedance Loads

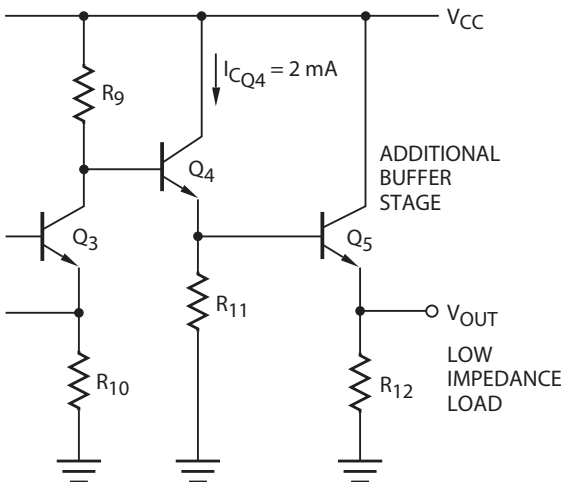
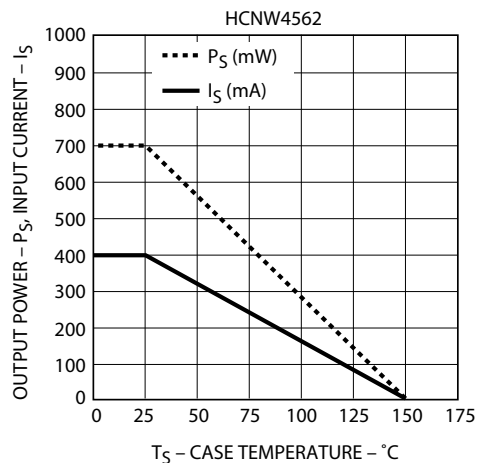

Figure 28 Thermal Derating Curve (Dependence of Safety Limiting Value with Case Temperature per IEC/EN/DIN EN 60747-5-5)



Conversion from HCPL4562 to HCNW4562

In order to obtain similar circuit performance when converting from the HCPL-4562 to the HCNW4562, it is recommended to increase the Quiescent Input Current, I_{FQ} , from 6 mA to 10 mA. If the application circuit in Figure 4 is used, then potentiometer R_4 should be adjusted appropriately.

Design Considerations of the Application Circuit

The application circuit in Figure 4 incorporates several features that help maximize the bandwidth performance of the HCPL-4562/HCNW4562. Most important of these features is peaked response of the detector circuit that helps extend the frequency range over which the voltage gain is relatively constant. The number of gain stages, the overall circuit topology, and the choice of DC bias points are all consequences of the desire to maximize bandwidth performance.

To use the circuit, first select R_1 to set V_E for the desired LED quiescent current by:

$$I_{FQ} = \frac{V_E}{R_4} \gg \frac{G_V V_E R_{10}}{(I_{PB}/I_F) R_7 R_9} \quad (1)$$

For a constant value V_{INp-p} , the circuit topology (adjusting the gain with R_4) preserves linearity by keeping the modulation factor (MF) dependent only on V_E .

$$i_{Fp-p} \gg V_{IN}/R_4 \quad (2)$$

$$\frac{i_{Fp-p}}{I_{FQ}} \gg \frac{i_{PBp-p}}{I_{PBQ}} = \frac{V_{INp-p}}{V_E} \quad (3)$$

Modulation:

$$\text{Factor (MF): } \frac{i_{F(p-p)}}{2 I_{FQ}} = \frac{V_{INp-p}}{2 V_E} \quad (4)$$

For a given G_V , V_E , and V_{CC} , DC output voltage will vary only with h_{FEX} :

$$V_O = V_{CC} - V_{BE4} - \frac{R_9}{R_{10}} [V_{BEX} - (I_{PBQ} - I_{BXQ}) R_7] \quad (5)$$

Where:

$$I_{PBQ} \gg \frac{G_V V_E R_{10}}{R_7 R_9} \quad (6)$$

and,

$$I_{BXQ} \gg \frac{V_{CC} - 2 V_{BE}}{R_6 h_{FEX}} \quad (7)$$

Figure 25 and Figure 26 shows the dependency of the DC output voltage on h_{FEX} .

For $9V < V_{CC} < 12V$, select the value of R_{11} such that:

$$I_{CQ4} \gg \frac{V_O}{R_{11}} = \frac{4.25V}{470} = 9.0 \text{ mA} \quad (8)$$

The voltage gain of the second state (Q_3) is approximately equal to:

$$\frac{R_9}{R_{10}} * \frac{1}{1 + s R_9 \left[C_{CQ3} + \frac{1}{2 R_{11} f_{T4}} \right]} \quad (9)$$

Increasing R'_{11} (R'_{11} includes the parallel combination of R_{11} and the load impedance) or reducing R_9 (keeping R_9/R_{10} ratio constant) will improve the bandwidth.

If it is necessary to drive a low-impedance load, bandwidth may also be preserved by adding an additional emitter following the buffer stage (Q_5 in Figure 16), in which case R_{11} can be increased to set $I_{CQ4} \approx 2 \text{ mA}$.

Finally, adjust R_4 to achieve the desired voltage gain:

$$G_V \gg \frac{V_{OUT}}{V_{IN}} \gg \frac{I_{PB}}{I_F} \left[\frac{R_7 R_9}{R_4 R_{10}} \right] \quad (10)$$

where typically $\frac{I_{PB}}{I_F} = 0.0032$

Definitions:

- G_V = Voltage Gain
- I_{FQ} = Quiescent LED forward current
- i_{Fp-p} = Peak-to-peak small-signal LED forward current
- V_{INp-p} = Peak-to-peak small-signal input voltage
- i_{PBp-p} = Peak-to-peak small-signal base photo current
- I_{PBQ} = Quiescent base photo current
- V_{BEX} = Base-Emitter voltage of HCPL-4562/HCNW4562 transistor
- I_{BXQ} = Quiescent base current of HCPL-4562/HCNW4562 transistor
- h_{FEX} = Current Gain (I_C/I_B) of HCPL-4562/HCNW4562 transistor
- V_E = Voltage across emitter degeneration resistor R_4
- f_{T4} = Unity gain frequency of Q_5
- C_{CQ3} = Effective capacitance from collector of Q_3 to ground

For product information and a complete list of distributors, please go to our web site: www.broadcom.com.

Broadcom, the pulse logo, Connecting everything, Avago Technologies, Avago, and the A logo are among the trademarks of Broadcom and/or its affiliates in the United States, certain other countries and/or the EU.

Copyright © 2017 by Broadcom. All Rights Reserved.

The term "Broadcom" refers to Broadcom Limited and/or its subsidiaries. For more information, please visit www.broadcom.com.

Broadcom reserves the right to make changes without further notice to any products or data herein to improve reliability, function, or design.



Information furnished by Broadcom is believed to be accurate and reliable. However, Broadcom does not assume any liability arising out of the application or use of this information, nor the application or use of any product or circuit described herein, neither does it convey any license under its patent rights nor the rights of others.

AV02-1361EN – July 12, 2017



Looking for pricing, stock, or lifecycle information?

Click below to explore more details on WIN SOURCE:

-  [View FCH35N60 on WIN SOURCE](#)
-  [Fairchild/ON Semiconductor Information](#)

Optimize Your Supply Chain with WIN SOURCE Solutions

-  Global Sourcing Solution
-  Obsolete Management
-  Cost Control Management
-  Shortage Management
-  Alternative Solution
-  Excess Inventory Management