



**THE DATASHEET OF
FDP3632**





ON Semiconductor®

FDH3632 / FDP3632 / FDB3632

N-Channel PowerTrench® MOSFET

100 V, 80 A, 9 mΩ

Features

- $R_{DS(ON)} = 7.5 \text{ m}\Omega$ (Typ.), $V_{GS} = 10 \text{ V}$, $I_D = 80 \text{ A}$
- $Q_g(\text{tot}) = 84 \text{ nC}$ (Typ.), $V_{GS} = 10 \text{ V}$
- Low Miller Charge
- Low Q_{rr} Body Diode
- UIS Capability (Single Pulse and Repetitive Pulse)
- RoHS Compliant

Applications

- Synchronous Rectification
- Battery Protection Circuit
- Motor Drives and Uninterruptible Power Supplies
- Micro Solar Inverter

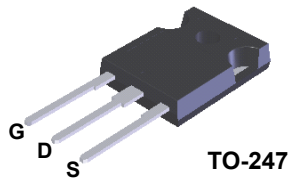

TO-247

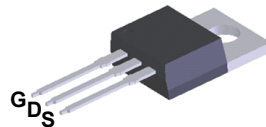

TO-220

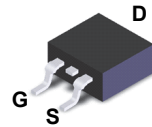

D²-PAK

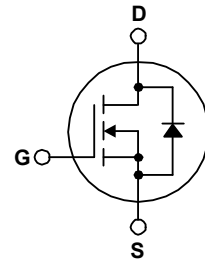

MOSFET Maximum Ratings $T_C = 25^\circ\text{C}$ unless otherwise noted

Symbol	Parameter	FDH3632 / FDP3632 / FDB3632	Unit
V_{DSS}	Drain to Source Voltage	100	V
V_{GS}	Gate to Source Voltage	± 20	V
I_D	Drain Current		
	Continuous ($T_C < 111^\circ\text{C}$, $V_{GS} = 10\text{V}$)	80	A
	Continuous ($T_{amb} = 25^\circ\text{C}$, $V_{GS} = 10\text{V}$, $R_{\theta JA} = 43^\circ\text{C/W}$)	12	A
	Pulsed	Figure 4	A
E_{AS}	Single Pulse Avalanche Energy (Note 1)	337	mJ
P_D	Power dissipation	310	W
	Derate above 25°C	2.07	W/ $^\circ\text{C}$
T_J, T_{STG}	Operating and Storage Temperature	-55 to 175	$^\circ\text{C}$

Thermal Characteristics

$R_{\theta JC}$	Thermal Resistance Junction to Case, Max. TO-220, D ² -PAK, TO-247	0.48	$^\circ\text{C/W}$
$R_{\theta JA}$	Thermal Resistance Junction to Ambient, Max. TO-220 (Note 2)	62	$^\circ\text{C/W}$
$R_{\theta JA}$	Thermal Resistance Junction to Ambient D ² -PAK, Max. 1in ² copper pad area	43	$^\circ\text{C/W}$
$R_{\theta JA}$	Thermal Resistance Junction to Ambient, Max. TO-247 (Note 2)	30	$^\circ\text{C/W}$

Package Marking and Ordering Information

Device Marking	Device	Package	Reel Size	Tape Width	Quantity
FDB3632	FDB3632	D ² -PAK	330 mm	24 mm	800 units
FDP3632	FDP3632	TO-220	Tube	N/A	50 units
FDH3632	FDH3632	TO-247	Tube	N/A	30 units

Electrical Characteristics $T_C = 25^\circ\text{C}$ unless otherwise noted

Symbol	Parameter	Test Conditions	Min	Typ	Max	Units
--------	-----------	-----------------	-----	-----	-----	-------

Off Characteristics

B_{VDSS}	Drain to Source Breakdown Voltage	$I_D = 250\mu\text{A}$, $V_{GS} = 0\text{V}$	100	-	-	V
I_{DSS}	Zero Gate Voltage Drain Current	$V_{DS} = 80\text{V}$ $V_{GS} = 0\text{V}$ $T_C = 150^\circ\text{C}$	-	-	1	μA
I_{GSS}	Gate to Source Leakage Current	$V_{GS} = \pm 20\text{V}$	-	-	± 100	nA

On Characteristics

$V_{GS(TH)}$	Gate to Source Threshold Voltage	$V_{GS} = V_{DS}$, $I_D = 250\mu\text{A}$	2	-	4	V
$r_{DS(ON)}$	Drain to Source On Resistance	$I_D = 80\text{A}$, $V_{GS} = 10\text{V}$	-	0.0075	0.009	Ω
		$I_D = 40\text{A}$, $V_{GS} = 6\text{V}$,	-	0.009	0.015	
		$I_D = 80\text{A}$, $V_{GS} = 10\text{V}$, $T_C = 175^\circ\text{C}$	-	0.018	0.022	

Dynamic Characteristics

C_{ISS}	Input Capacitance	$V_{DS} = 25\text{V}$, $V_{GS} = 0\text{V}$, $f = 1\text{MHz}$	-	6000	-	pF
C_{OSS}	Output Capacitance		-	820	-	pF
C_{RSS}	Reverse Transfer Capacitance		-	200	-	pF
$Q_{g(TOT)}$	Total Gate Charge at 10V	$V_{GS} = 0\text{V}$ to 10V	-	84	110	nC
$Q_{g(TH)}$	Threshold Gate Charge	$V_{GS} = 0\text{V}$ to 2V	-	11	14	nC
Q_{gs}	Gate to Source Gate Charge	$V_{DD} = 50\text{V}$ $I_D = 80\text{A}$ $I_g = 1.0\text{mA}$	-	30	-	nC
Q_{gs2}	Gate Charge Threshold to Plateau		-	20	-	nC
Q_{gd}	Gate to Drain "Miller" Charge		-	20	-	nC

Resistive Switching Characteristics ($V_{GS} = 10\text{V}$)

t_{ON}	Turn-On Time	$V_{DD} = 50\text{V}$, $I_D = 80\text{A}$ $V_{GS} = 10\text{V}$, $R_{GS} = 3.6\Omega$	-	-	102	ns
$t_{d(ON)}$	Turn-On Delay Time		-	30	-	ns
t_r	Rise Time		-	39	-	ns
$t_{d(OFF)}$	Turn-Off Delay Time		-	96	-	ns
t_f	Fall Time		-	46	-	ns
t_{OFF}	Turn-Off Time		-	-	213	ns

Drain-Source Diode Characteristics

V_{SD}	Source to Drain Diode Voltage	$I_{SD} = 80\text{A}$	-	-	1.25	V
		$I_{SD} = 40\text{A}$	-	-	1.0	V
t_{rr}	Reverse Recovery Time	$I_{SD} = 75\text{A}$, $dI_{SD}/dt = 100\text{A}/\mu\text{s}$	-	-	64	ns
Q_{RR}	Reverse Recovered Charge	$I_{SD} = 75\text{A}$, $dI_{SD}/dt = 100\text{A}/\mu\text{s}$	-	-	120	nC

Notes:

- Starting $T_J = 25^\circ\text{C}$, $L = 0.12\text{mH}$, $I_{AS} = 75\text{A}$, $V_{DD} = 80\text{V}$.
- Pulse Width = 100s

Typical Characteristics $T_C = 25^\circ\text{C}$ unless otherwise noted

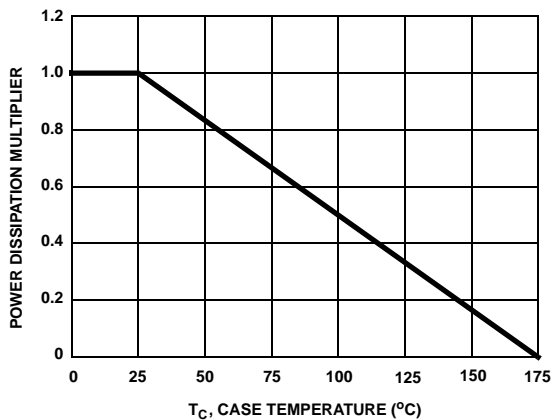

Figure 1. Normalized Power Dissipation vs Ambient Temperature

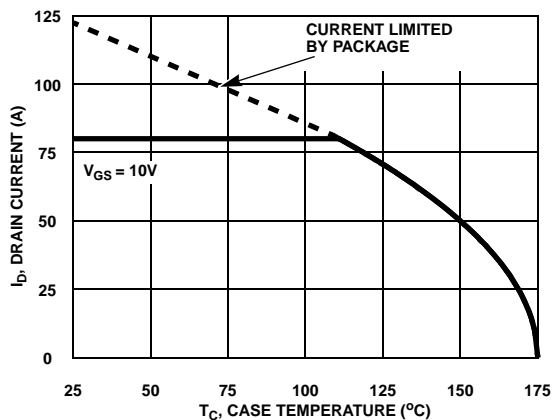

Figure 2. Maximum Continuous Drain Current vs Case Temperature

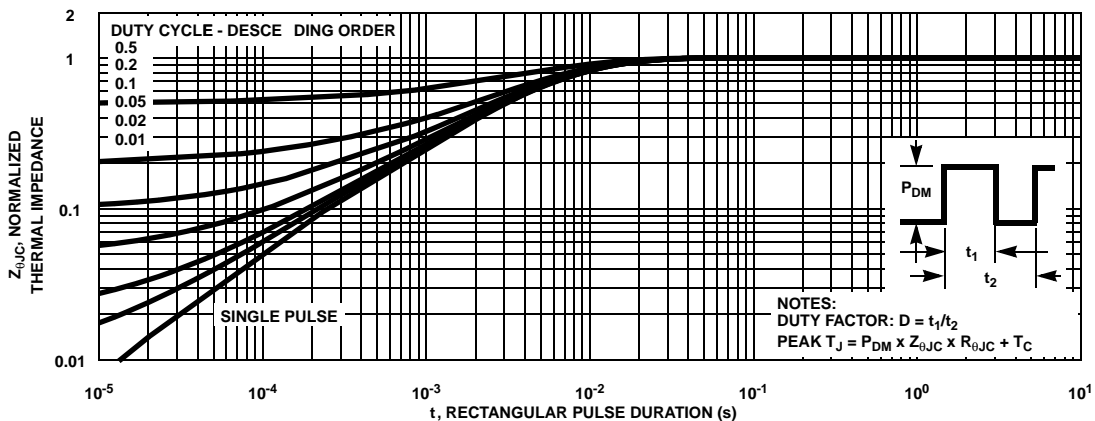

Figure 3. Normalized Maximum Transient Thermal Impedance

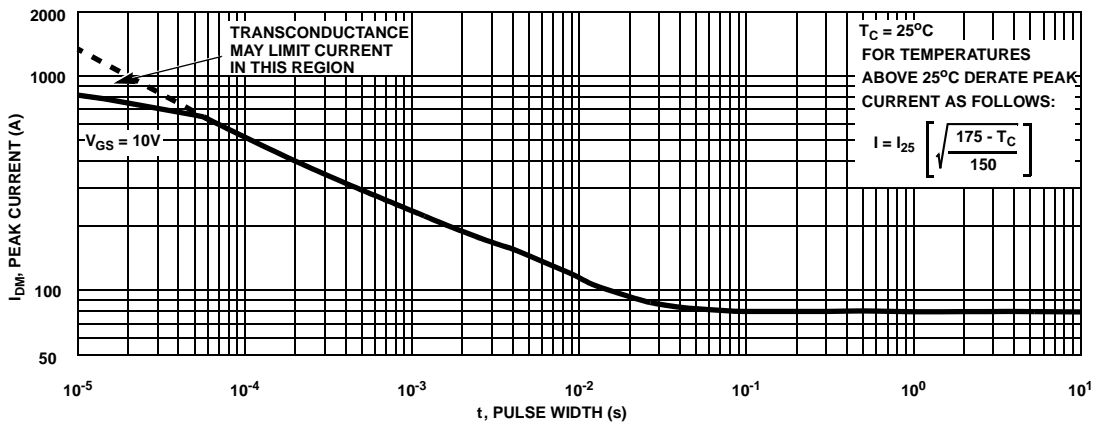

Figure 4. Peak Current Capability

Typical Characteristics $T_C = 25^\circ\text{C}$ unless otherwise noted

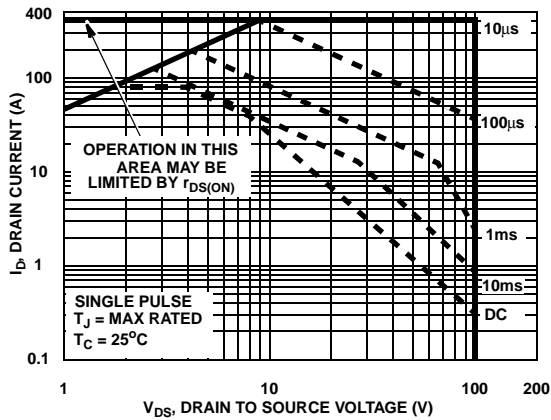
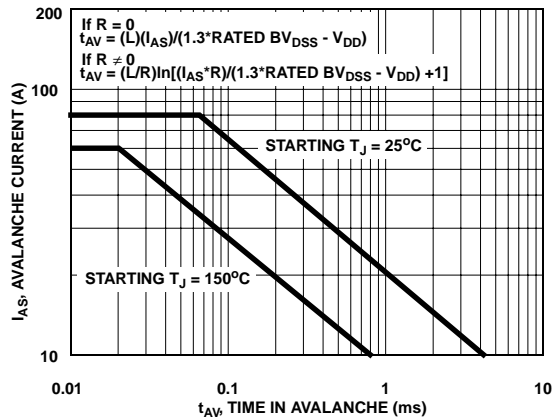

Figure 5. Forward Bias Safe Operating Area



NOTE: Refer to ON Semiconductor Application Notes AN7514 and AN7515

Figure 6. Unclamped Inductive Switching Capability

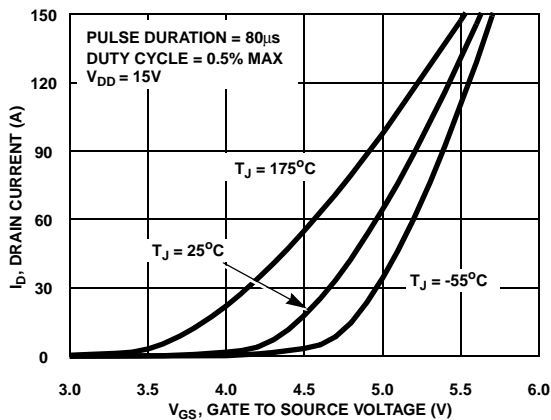

Figure 7. Transfer Characteristics

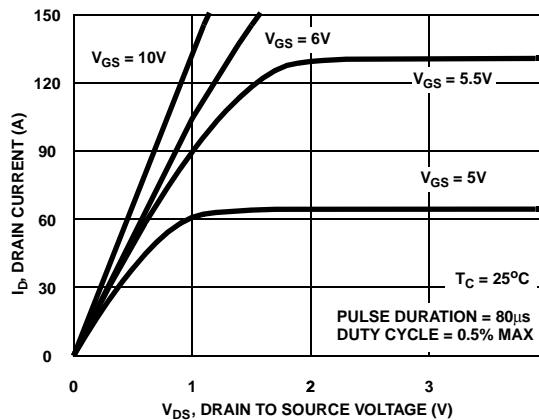

Figure 8. Saturation Characteristics

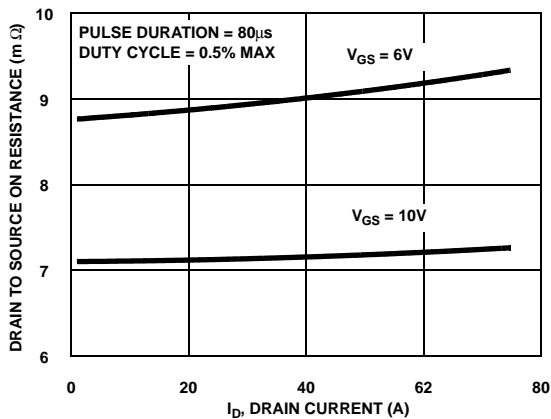

Figure 9. Drain to Source On Resistance vs Drain Current

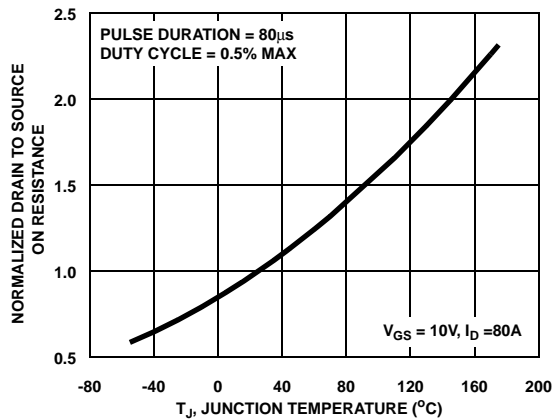

Figure 10. Normalized Drain to Source On Resistance vs Junction Temperature

Typical Characteristics $T_C = 25^\circ\text{C}$ unless otherwise noted

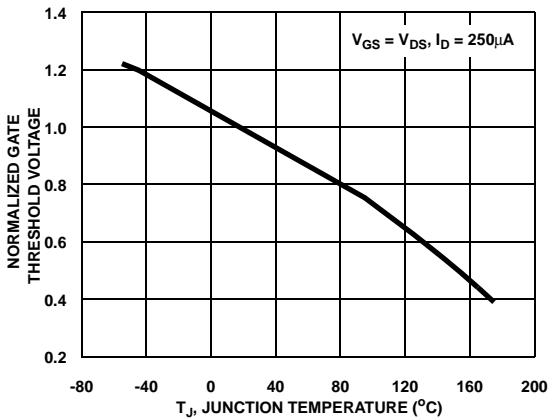

Figure 11. Normalized Gate Threshold Voltage vs Junction Temperature

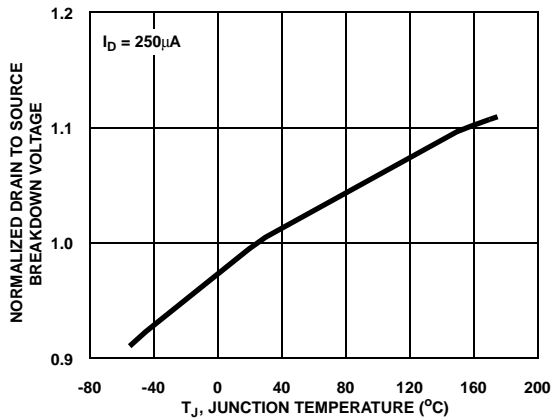

Figure 12. Normalized Drain to Source Breakdown Voltage vs Junction Temperature

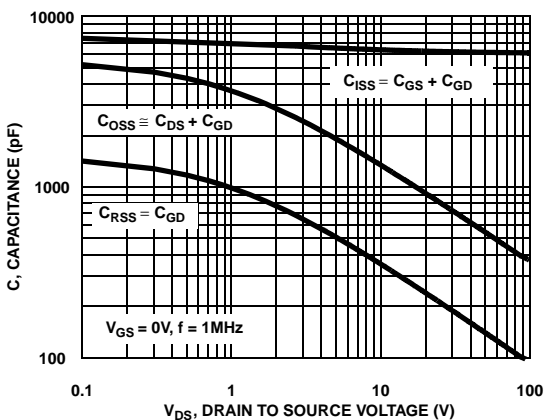

Figure 13. Capacitance vs Drain to Source Voltage

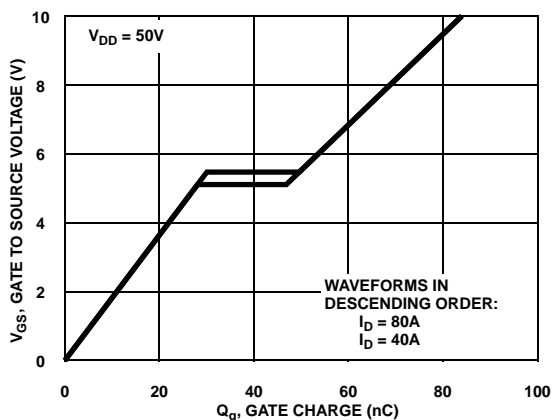

Figure 14. Gate Charge Waveforms for Constant Gate Currents

Test Circuits and Waveforms

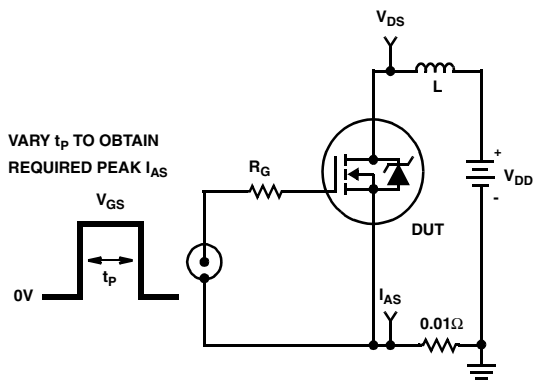

Figure 15. Unclamped Energy Test Circuit

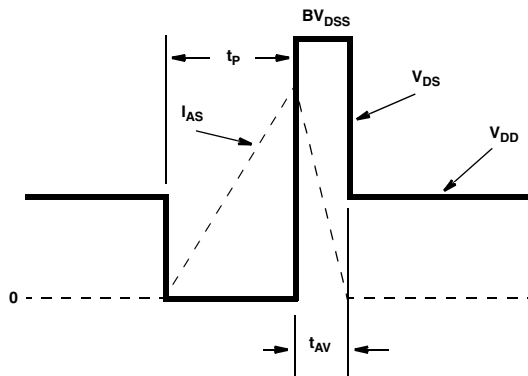

Figure 16. Unclamped Energy Waveforms

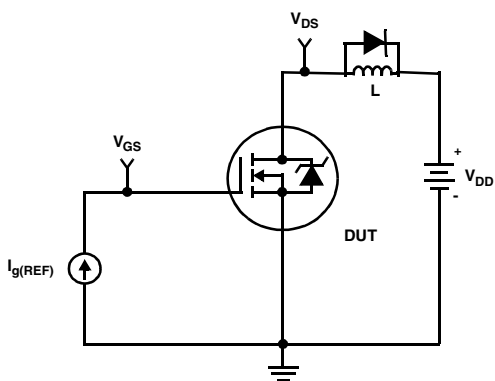

Figure 17. Gate Charge Test Circuit

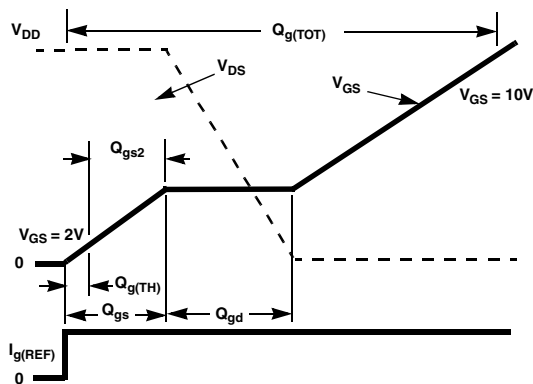

Figure 18. Gate Charge Waveforms

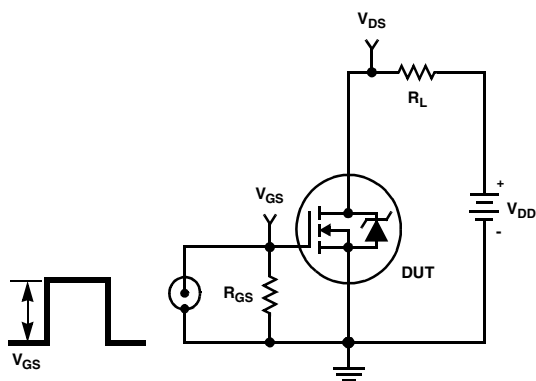

Figure 19. Switching Time Test Circuit

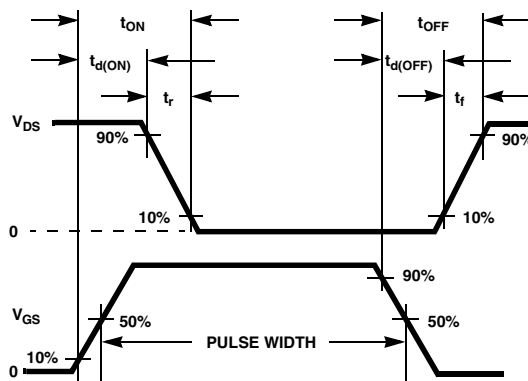

Figure 20. Switching Time Waveforms

Thermal Resistance vs. Mounting Pad Area

The maximum rated junction temperature, T_{JM} , and the thermal resistance of the heat dissipating path determines the maximum allowable device power dissipation, P_{DM} , in an application. Therefore the application's ambient temperature, T_A ($^{\circ}C$), and thermal resistance $R_{\theta JA}$ ($^{\circ}C/W$) must be reviewed to ensure that T_{JM} is never exceeded. Equation 1 mathematically represents the relationship and serves as the basis for establishing the rating of the part.

$$P_{DM} = \frac{(T_{JM} - T_A)}{R_{\theta JA}} \quad (\text{EQ. 1})$$

In using surface mount devices such as the TO-263 package, the environment in which it is applied will have a significant influence on the part's current and maximum power dissipation ratings. Precise determination of P_{DM} is complex and influenced by many factors:

1. Mounting pad area onto which the device is attached and whether there is copper on one side or both sides of the board.
2. The number of copper layers and the thickness of the board.
3. The use of external heat sinks.
4. The use of thermal vias.
5. Air flow and board orientation.
6. For non steady state applications, the pulse width, the duty cycle and the transient thermal response of the part, the board and the environment they are in.

ON Semiconductor provides thermal information to assist the designer's preliminary application evaluation. Figure 21

defines the $R_{\theta JA}$ for the device as a function of the top copper (component side) area. This is for a horizontally positioned FR-4 board with 1oz copper after 1000 seconds of steady state power with no air flow. This graph provides the necessary information for calculation of the steady state junction temperature or power dissipation. Pulse applications can be evaluated using the ON Semiconductor device Spice thermal model or manually utilizing the normalized maximum transient thermal impedance curve.

Thermal resistances corresponding to other copper areas can be obtained from Figure 21 or by calculation using Equation 2 or 3. Equation 2 is used for copper area defined in inches square and equation 3 is for area in centimeter square. The area, in square inches or square centimeters is the top copper area including the gate and source pads.

$$R_{\theta JA} = 26.51 + \frac{19.84}{(0.262 + Area)} \quad (\text{EQ. 2})$$

Area in Inches Squared

$$R_{\theta JA} = 26.51 + \frac{128}{(1.69 + Area)} \quad (\text{EQ. 3})$$

Area in Centimeter Squared

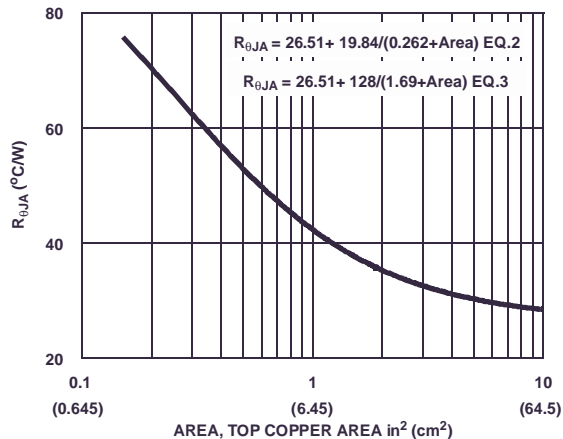

Figure 21. Thermal Resistance vs Mounting Pad Area

PSPICE Electrical Model

.SUBCKT FDB3632 2 1 3; rev May 2002
 CA 12 8 1.7e-9
 Cb 15 14 2.5e-9
 Cin 6 8 6.0e-9

Dbody 7 5 DbodyMOD
 Dbreak 5 11 DbreakMOD
 Dplcap 10 5 DplcapMOD

Ebbreak 11 7 17 18 102.5
 Eds 14 8 5 8 1
 Egs 13 8 6 8 1
 Esg 6 10 6 8 1
 Evthres 6 21 19 8 1
 Evtemp 20 6 18 22 1

It 8 17 1

Lgate 1 9 5.61e-9
 Ldrain 2 5 1.0e-9
 Lsource 3 7 2.7e-9

RLgate 1 9 56.1
 RLdrain 2 5 10
 RLsource 3 7 27

Mmed 16 6 8 8 MmedMOD
 Mstro 16 6 8 8 MstroMOD
 Mweak 16 21 8 8 MweakMOD

Rbreak 17 18 RbreakMOD 1
 Rdrain 50 16 RdrainMOD 3.8e-3
 Rgate 9 20 1.1
 RSLC1 5 51 RSLCMOD 1.0e-6
 RSLC2 5 50 1.0e3
 Rsource 8 7 RsourceMOD 2.5e-3
 Rvthres 22 8 RvthresMOD 1
 Rvtemp 18 19 RvtempMOD 1
 S1a 6 12 13 8 S1AMOD
 S1b 13 12 13 8 S1BMOD
 S2a 6 15 14 13 S2AMOD
 S2b 13 15 14 13 S2BMOD

Vbat 22 19 DC 1

ESLC 51 50 VALUE={ (V(5,51)/ABS(V(5,51))) * (PWR(V(5,51))/(1e-6*350),3) }

.MODEL DbodyMOD D (IS=5.9E-11 N=1.07 RS=2.3e-3 TRS1=3.0e-3 TRS2=1.0e-6
 + CJO=4e-9 M=0.58 TT=4.8e-8 XTI=4.2)
 .MODEL DbreakMOD D (RS=0.17 TRS1=3.0e-3 TRS2=-8.9e-6)
 .MODEL DplcapMOD D (CJO=15e-10 IS=1.0e-30 N=10 M=0.6)
 .MODEL MstroMOD NMOS (VTO=4.1 KP=200 IS=1e-30 N=10 TOX=1 L=1u W=1u)
 .MODEL MmedMOD NMOS (VTO=3.4 KP=10.0 IS=1e-30 N=10 TOX=1 L=1u W=1u RG=1.1)
 .MODEL MweakMOD NMOS (VTO=2.75 KP=0.05 IS=1e-30 N=10 TOX=1 L=1u W=1u RG=1.1e+1 RS=0.1)

.MODEL RbreakMOD RES (TC1=1.0e-3 TC2=-1.7e-6)
 .MODEL RdrainMOD RES (TC1=8.5e-3 TC2=2.8e-5)
 .MODEL RSLCMOD RES (TC1=2.0e-3 TC2=2.0e-6)
 .MODEL RsourceMOD RES (TC1=4e-3 TC2=1e-6)
 .MODEL RvthresMOD RES (TC1=-4.0e-3 TC2=-1.8e-5)
 .MODEL RvtempMOD RES (TC1=-4.4e-3 TC2=2.2e-6)

.MODEL S1AMOD VSWITCH (RON=1e-5 ROFF=0.1 VON=-4 VOFF=-2)
 .MODEL S1BMOD VSWITCH (RON=1e-5 ROFF=0.1 VON=-2 VOFF=-4)
 .MODEL S2AMOD VSWITCH (RON=1e-5 ROFF=0.1 VON=-0.8 VOFF=0.4)
 .MODEL S2BMOD VSWITCH (RON=1e-5 ROFF=0.1 VON=0.4 VOFF=-0.8)

.ENDS

Note: For further discussion of the PSPICE model, consult **A New PSPICE Sub-Circuit for the Power MOSFET Featuring Global Temperature Options**; IEEE Power Electronics Specialist Conference Records, 1991, written by William J. Hepp and C. Frank Wheatley.

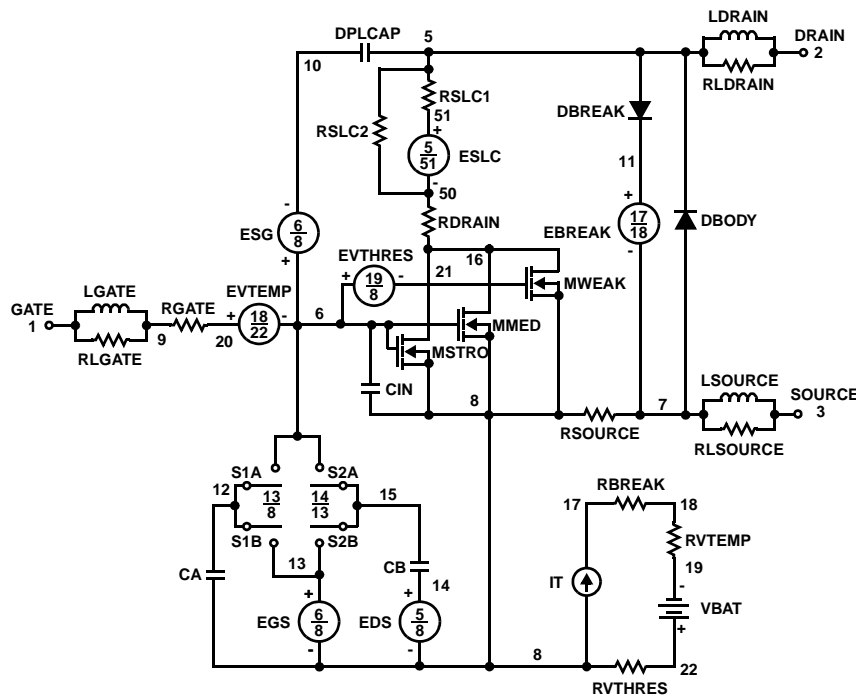

SPICE Thermal Model

REV May 2002

FDB3632

CTHERM1 TH 6 7.5e-3
 CTHERM2 6 5 8.0e-3
 CTHERM3 5 4 9.0e-3
 CTHERM4 4 3 2.4e-2
 CTHERM5 3 2 3.4e-2
 CTHERM6 2 TL 6.5e-2

RTHERM1 TH 6 3.1e-4
 RTHERM2 6 5 2.5e-3
 RTHERM3 5 4 2.2e-2
 RTHERM4 4 3 8.1e-2
 RTHERM5 3 2 1.35e-1
 RTHERM6 2 TL 1.5e-1

SABER Thermal Model

SABER thermal model FDB3632

template thermal_model th tl
 thermal_c th, tl

```
{
ctherm.ctherm1 th 6 =7.5e-3
ctherm.ctherm2 6 5 =8.0e-3
ctherm.ctherm3 5 4 =9.0e-3
ctherm.ctherm4 4 3 =2.4e-2
ctherm.ctherm5 3 2 =3.4e-2
ctherm.ctherm6 2 tl =6.5e-2
```

```
rtherm.rtherm1 th 6 =3.1e-4
rtherm.rtherm2 6 5 =2.5e-3
rtherm.rtherm3 5 4 =2.2e-2
rtherm.rtherm4 4 3 =8.1e-2
rtherm.rtherm5 3 2 =1.35e-1
rtherm.rtherm6 2 tl =1.5e-1
}
```

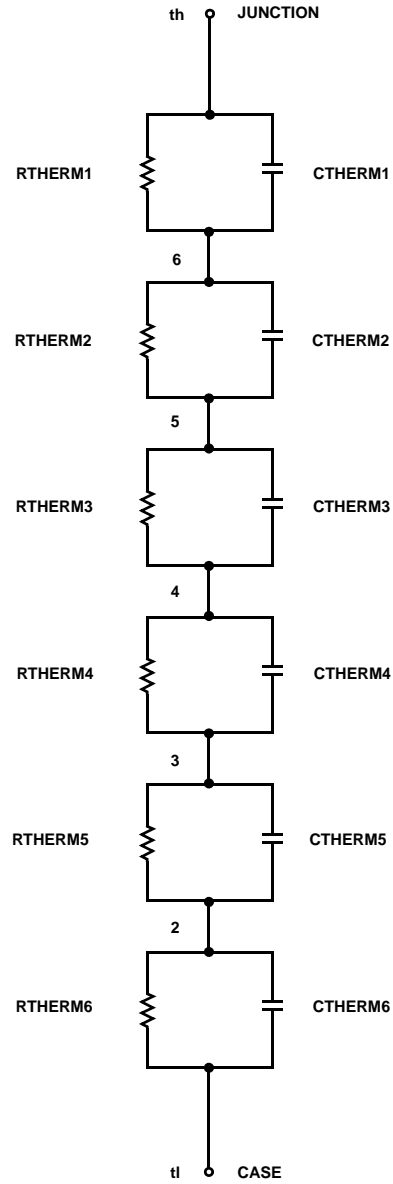

Mechanical Dimensions

TO-220 3L

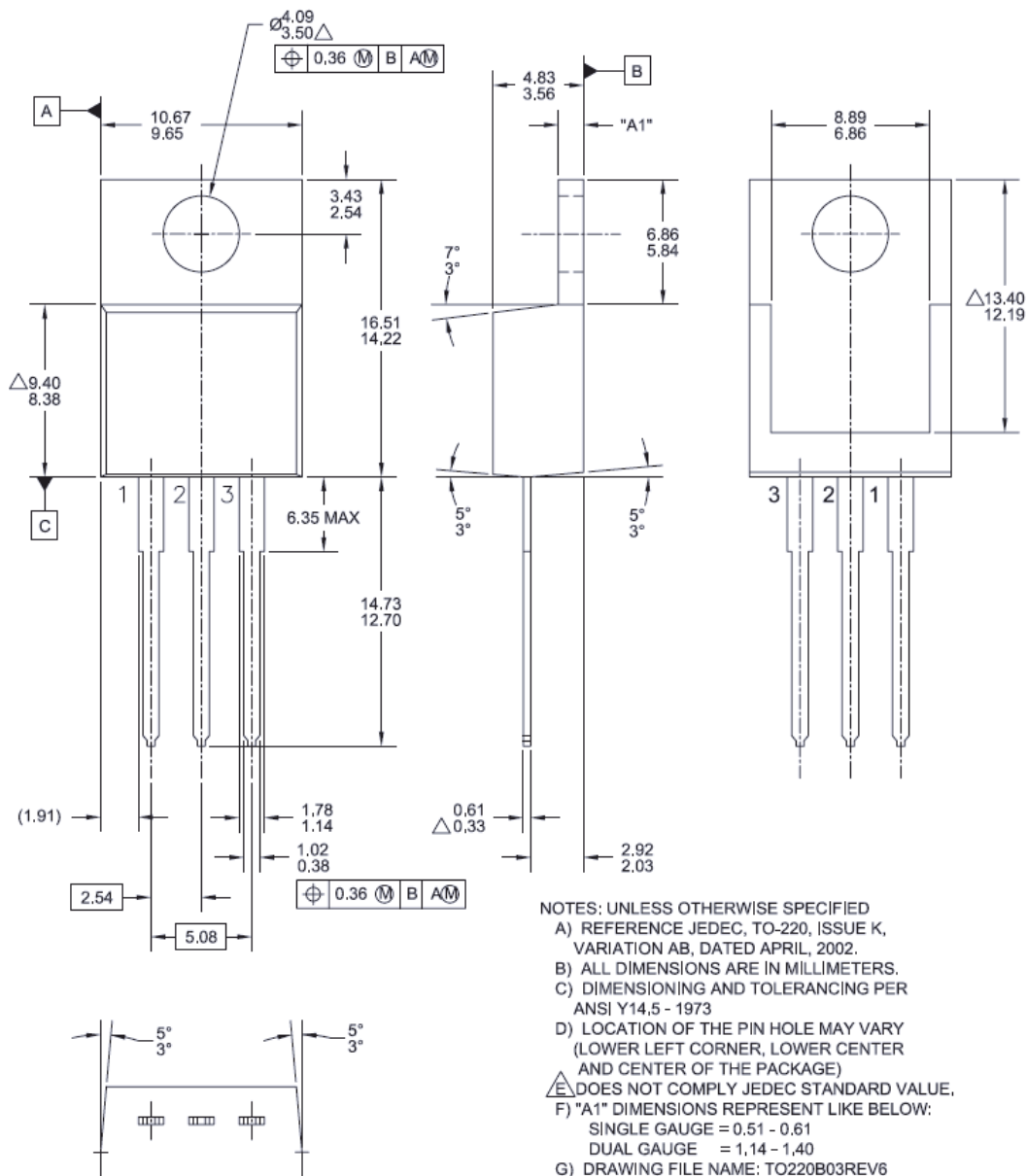

Figure 23. TO-220, Molded, 3Lead, Jedec Variation AB

Package drawings are provided as a service to customers considering ON Semiconductor components. Drawings may change in any manner without notice. Please note the revision and/or date on the drawing and contact a ON Semiconductor representative to verify or obtain the most recent revision. Package specifications do not expand the terms of ON Semiconductor worldwide terms and conditions, specifically the warranty therein, which covers ON Semiconductor products.

Dimension in Millimeters

Mechanical Dimensions

TO-263 2L (D²PAK)

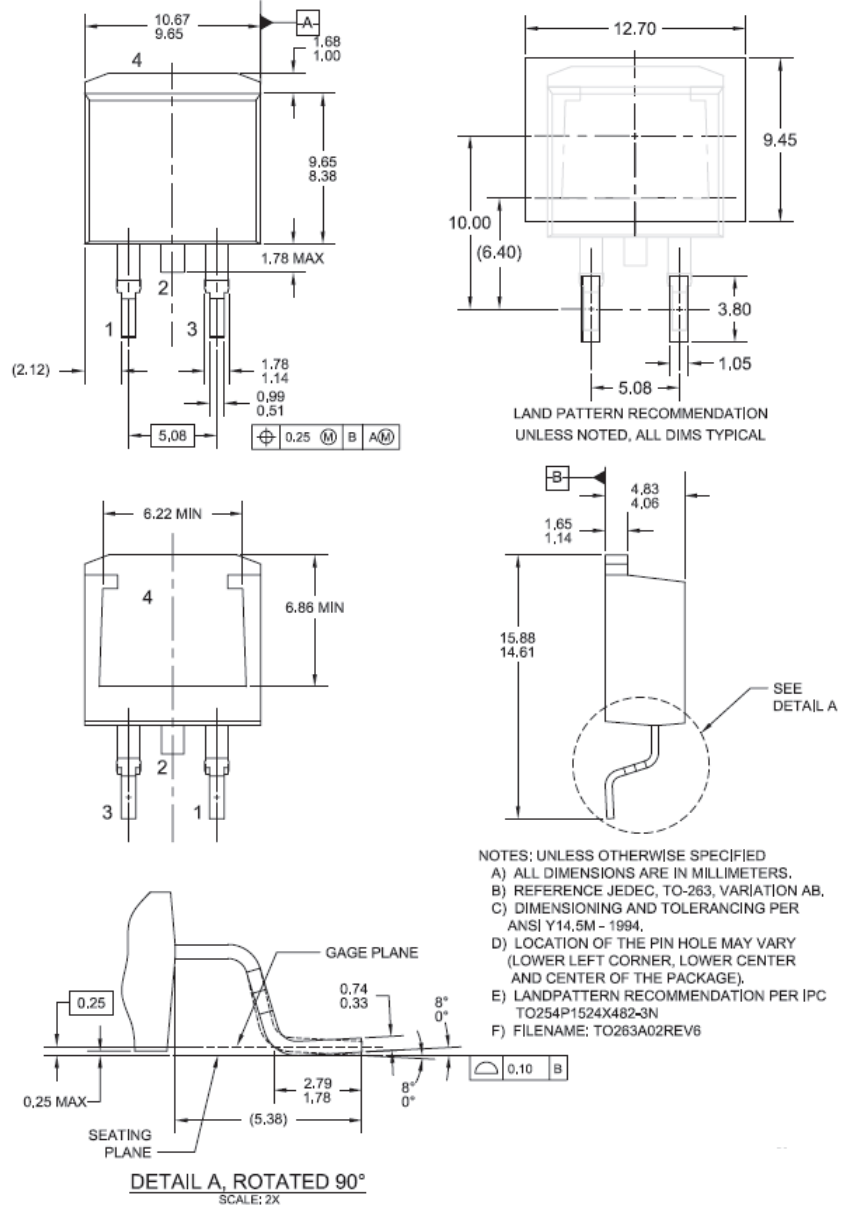



Figure 24. 2LD, TO263, Surface Mount

Package drawings are provided as a service to customers considering ON Semiconductor components. Drawings may change in any manner without notice. Please note the revision and/or date on the drawing and contact a ON Semiconductor representative to verify or obtain the most recent revision. Package specifications do not expand the terms of ON Semiconductor worldwide terms and conditions, specifically the warranty therein, which covers ON Semiconductor products.

Dimension in Millimeters

ON Semiconductor and  are trademarks of Semiconductor Components Industries, LLC dba ON Semiconductor or its subsidiaries in the United States and/or other countries. ON Semiconductor owns the rights to a number of patents, trademarks, copyrights, trade secrets, and other intellectual property. A listing of ON Semiconductor's product/patent coverage may be accessed at www.onsemi.com/site/pdf/Patent-Marking.pdf. ON Semiconductor reserves the right to make changes without further notice to any products herein. ON Semiconductor makes no warranty, representation or guarantee regarding the suitability of its products for any particular purpose, nor does ON Semiconductor assume any liability arising out of the application or use of any product or circuit, and specifically disclaims any and all liability, including without limitation special, consequential or incidental damages. Buyer is responsible for its products and applications using ON Semiconductor products, including compliance with all laws, regulations and safety requirements or standards, regardless of any support or applications information provided by ON Semiconductor. "Typical" parameters which may be provided in ON Semiconductor data sheets and/or specifications can and do vary in different applications and actual performance may vary over time. All operating parameters, including "Typicals" must be validated for each customer application by customer's technical experts. ON Semiconductor does not convey any license under its patent rights nor the rights of others. ON Semiconductor products are not designed, intended, or authorized for use as a critical component in life support systems or any FDA Class 3 medical devices or medical devices with a same or similar classification in a foreign jurisdiction or any devices intended for implantation in the human body. Should Buyer purchase or use ON Semiconductor products for any such unintended or unauthorized application, Buyer shall indemnify and hold ON Semiconductor and its officers, employees, subsidiaries, affiliates, and distributors harmless against all claims, costs, damages, and expenses, and reasonable attorney fees arising out of, directly or indirectly, any claim of personal injury or death associated with such unintended or unauthorized use, even if such claim alleges that ON Semiconductor was negligent regarding the design or manufacture of the part. ON Semiconductor is an Equal Opportunity/Affirmative Action Employer. This literature is subject to all applicable copyright laws and is not for resale in any manner.

PUBLICATION ORDERING INFORMATION

LITERATURE FULFILLMENT:



Literature Distribution Center for ON Semiconductor
19521 E. 32nd Pkwy, Aurora, Colorado 80011 USA
Phone: 303-675-2175 or 800-344-3860 Toll Free USA/Canada
Fax: 303-675-2176 or 800-344-3867 Toll Free USA/Canada
Email: orderlit@onsemi.com

N. American Technical Support: 800-282-9855 Toll Free
USA/Canada
Europe, Middle East and Africa Technical Support:
Phone: 421 33 790 2910
Japan Customer Focus Center
Phone: 81-3-5817-1050

ON Semiconductor Website: www.onsemi.com
Order Literature: <http://www.onsemi.com/orderlit>
For additional information, please contact your local
Sales Representative

Looking for pricing, stock, or lifecycle information?

Click below to explore more details on WIN SOURCE:

-  [View FDP3632 on WIN SOURCE](#)
-  [Fairchild/ON Semiconductor](#) Information

Optimize Your Supply Chain with WIN SOURCE Solutions

-  Global Sourcing Solution
-  Obsolete Management
-  Cost Control Management
-  Shortage Management
-  Alternative Solution
-  Excess Inventory Management