



THE DATASHEET OF FMA11A T148



Emitter common (dual digital transistors)

EMA11 / UMA11N / FMA11A

●Features

- 1) Two DTA143Z chips in a EMT or UMT or SMT package.
- 2) Mounting cost and area can be cut in half.

●Structure

Epitaxial planar type
 PNP silicon transistor
 (Built-in resistor type)

The following characteristics apply to both DTr₁ and DTr₂.

●Equivalent circuit

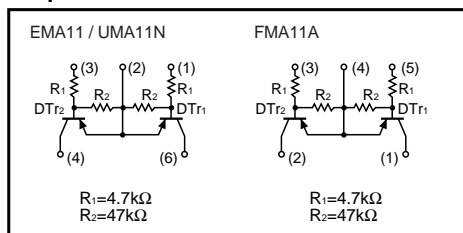

●Packaging specifications

Type	Package	Taping		
	Code	T2R	TR	T148
	Basic ordering unit (pieces)	8000	3000	3000
EMA11		○	-	-
UMA11N		-	○	-
FMA11A		-	-	○

●External dimensions (Unit : mm)

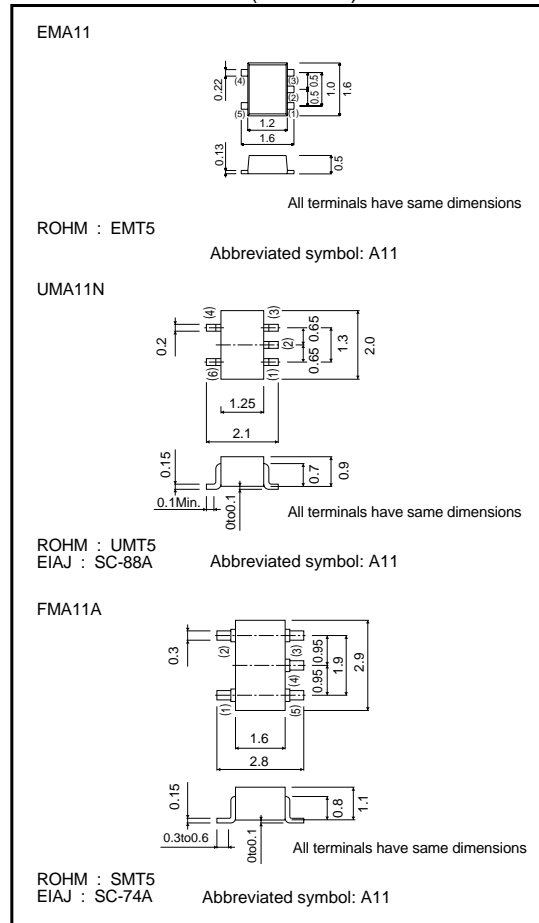

Transistors

●Absolute maximum ratings (Ta = 25°C)

Parameter		Symbol	Limits	Unit	
Supply voltage		V _{CC}	-50	V	
Input voltage		V _{IN}	-30	V	
			5		
Output current		I _o	-100	mA	
		I _{C (Max.)}	-100		
Power dissipation	EMA11 / UMA11N	P _d	150 (TOTAL)	mW	*1
	FMA11A		300 (TOTAL)		*2
Junction temperature		T _J	150	°C	
Storage temperature		T _{stg}	-55 to +150	°C	

*1 120mW per element must not be exceeded.
 *2 200mW per element must not be exceeded.

●Electrical characteristics (Ta = 25°C)

Parameter	Symbol	Min.	Typ.	Max.	Unit	Conditions
Input voltage	V _{I (off)}	-	-	-0.5	V	V _{CC} =-5V, I _o =-100μA
	V _{I (on)}	-1.3	-	-		V _O =-0.3V, I _o =-5mA
Output voltage	V _{O (on)}	-	-0.1	-0.3	V	I _o /I _i =-5mA/-0.25mA
Input current	I _i	-	-	-1.8	mA	V _I =-5V
Output current	I _{o (off)}	-	-	-0.5	μA	V _{CC} =-50V, V _I =0V
DC current gain	G _I	80	-	-	-	V _O =-5V, I _o =-10mA
Transition frequency	f _T	-	250	-	MHz	V _{CE} =10mA, I _E =-5mA, f=100MHz *
Input resistance	R ₁	3.29	4.7	6.11	kΩ	-
Resistance ratio	R ₂ /R ₁	8	10	12	-	-

* Transition frequency of the device

●Electrical characteristic curves

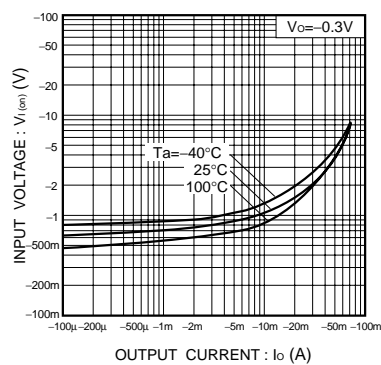

Fig.1 Input voltage vs. output current (ON characteristics)

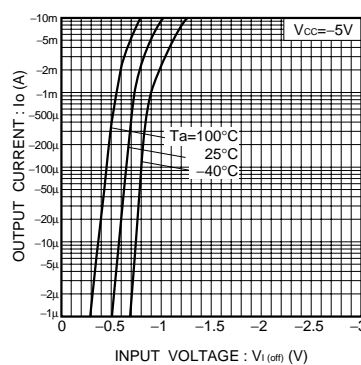

Fig.2 Output current vs. input voltage (OFF characteristics)

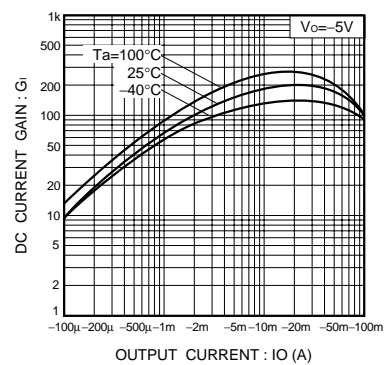

Fig.3 DC current gain vs. output current

Transistors

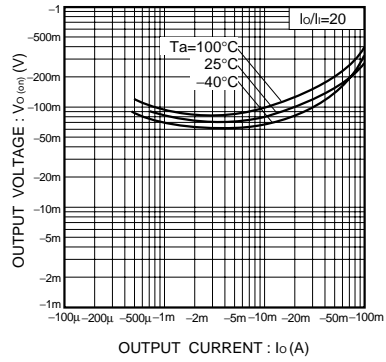

Fig.4 Output voltage vs. output current

Looking for pricing, stock, or lifecycle information?

Click below to explore more details on WIN SOURCE:

-  [View FMA11A T148 on WIN SOURCE](#)
-  [Rohm Semiconductor](#) Information

Optimize Your Supply Chain with WIN SOURCE Solutions

-  Global Sourcing Solution
-  Obsolete Management
-  Cost Control Management
-  Shortage Management
-  Alternative Solution
-  Excess Inventory Management