



THE DATASHEET OF FMG8AT148



Emitter common (dual digital transistors)

EMG8 / UMG8N / FMG8A

●Features

- 1) Two DTC143Z chips in a EMT or UMT or SMT package.
- 2) Mounting cost and area can be cut in half.

●Structure

Epitaxial planar type
NPN silicon transistor
(Built-in resistor type)

The following characteristics apply to both the DTr1 and DTr2.

●Equivalent circuit

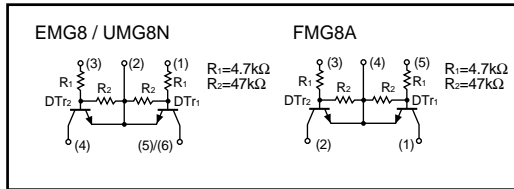

●Absolute maximum ratings (Ta = 25°C)

Parameter	Symbol	Limits	Unit
Supply voltage	V _{CC}	50	V
Input voltage	V _{IN}	30	V
		-5	
Output current	I _o	100	mA
	I _{c (Max.)}	100	
Power dissipation	EMG8, UMG8N	150 (TOTAL)	mW
	FMG8A	300 (TOTAL)	
Junction temperature	T _j	150	°C
Storage temperature	T _{stg}	-55~+150	°C

*1 120mW per element must not be exceeded.

*2 200mW per element must not be exceeded.

●External dimensions (Units : mm)

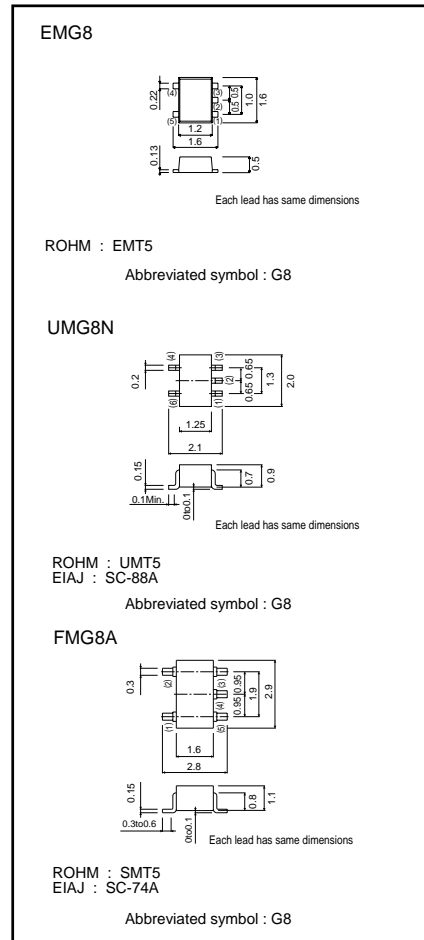

Transistors

●Electrical characteristics (Ta = 25°C)

Parameter	Symbol	Min.	Typ.	Max.	Unit	Conditions
Input voltage	$V_{I(off)}$	—	—	0.5	V	$V_{CC}=5V, I_o=100\mu A$
	$V_{I(on)}$	1.3	—	—		$V_o=0.3V, I_o=5mA$
Output voltage	$V_{O(on)}$	—	0.1	0.3	V	$I_o=5mA, I_i=0.25mA$
Input current	I_i	—	—	1.8	mA	$V_i=5V$
Output current	$I_{O(off)}$	—	—	0.5	μA	$V_{CC}=50V, V_i=0V$
DC current gain	G_i	80	—	—	—	$V_o=5V, I_o=10mA$
Transition frequency	f_T	—	250	—	MHz	$V_{CE}=10mA, I_e=-5mA, f=100MHz$ *
Input resistance	R_i	3.29	4.7	6.11	$k\Omega$	—
Resistance ratio	R_z/R_i	8	10	12	—	—

* Transition frequency of the device

●Packaging specifications

Type	Package	Taping		
	Code	T2R	TR	T148
	Basic ordering unit (pieces)	8000	3000	3000
EMG8	○	—	—	—
UMG8N	—	○	—	—
FMG8A	—	—	—	○

●Electrical characteristic curves

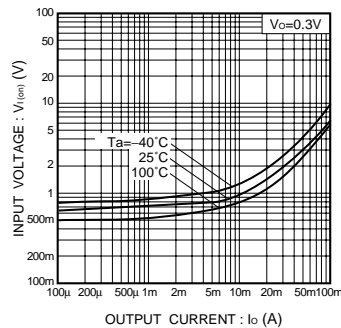

Fig.1 Input voltage vs. output current (ON characteristics)

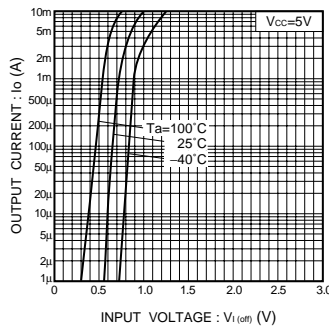

Fig.2 Output current vs. input voltage (OFF characteristics)

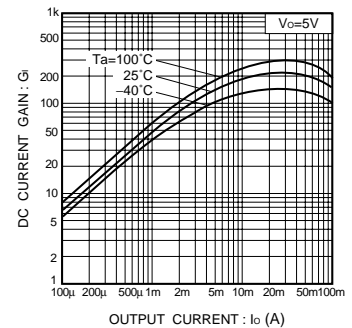

Fig.3 DC current gain vs. output current

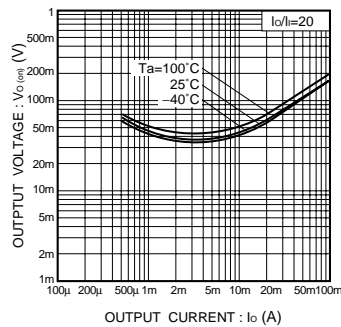



Fig.4 Output voltage vs. output current

Looking for pricing, stock, or lifecycle information?

Click below to explore more details on WIN SOURCE:

-  [View FMG8AT148](#) on WIN SOURCE
-  [Rohm Semiconductor](#) Information

Optimize Your Supply Chain with WIN SOURCE Solutions

-  Global Sourcing Solution
-  Obsolete Management
-  Cost Control Management
-  Shortage Management
-  Alternative Solution
-  Excess Inventory Management