

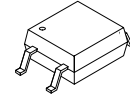

# THE DATASHEET OF FODM452R1V



# 5-Pin Mini Flat Package High Speed Transistor Optocoupler



MFP5 4.1X4.4, 2.54P  
CASE 100AM

## FODM452, FODM453

### Description

The FODM452 and FODM453 optocouplers consist of an AlGaAs LED optically coupled to a high speed photo-detector transistor. The devices are housed in a compact 5-pin mini flat package for optimum mounting density.

The FODM453 features a high CMR rating for optimum common mode transient immunity.

### Features

- Compact 5-pin Mini Flat Package
- High Speed – 1 MBit/s
- Superior CMR – 15 kV/μs at  $V_{CM} = 1500\text{ V}$  (FODM453)
- Performance Guaranteed over Temperature (0 – 70°C)
- U.L. Recognized (File # E90700)
- VDE0884 Recognized (File # 136480)  
– Ordering Option V, e.g., FODM452V
- 260°C Reflow Capability for Pb-free Assembly
- These are Pb-Free Devices

### Applications

- Line Receivers
- Pulse Transformer Replacement
- Output Interface to CMOS–LSTTL–TTL
- Wide Bandwidth Analog Coupling

### MARKING DIAGRAM

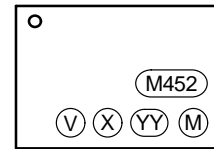

- M45x = Device Number (x = 2, 3)
- V = DIN EN/IEC60747-5-5 Mark (Note: Only Appears on Parts Ordered with VDE Option – See Order Entry Table)
- X = One Digit Year Code, e.g., '7'
- YY = Two Digit Work Week Ranging from '01' to '53'
- M = Assembly Package Code

### FUNCTIONAL SCHEMATIC

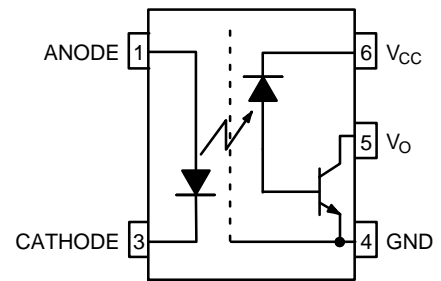

### TRUTH TABLE

LED	Output
Off	High
On	Low

### ORDERING INFORMATION

See detailed ordering and shipping information on page 10 of this data sheet.

# FODM452, FODM453

## PIN DEFINITIONS

Number	Name	Function Description
1	ANODE	Anode
3	CATHODE	Cathode
4	GND	Output Ground
5	$V_O$	Output Voltage
6	$V_{CC}$	Output Supply Voltage

## SAFETY AND INSULATION RATINGS FOR MINI-FLAT PACKAGE (SO5 PIN)

(As per DIN EN/IEC60747-5-5. This optocoupler is suitable for "safe electrical insulation" only within the safety limit data. Compliance with the safety ratings shall be ensured by means of protective circuits.)

Symbol	Parameter	Min	Typ	Max	Unit
	Installation Classifications per DIN VDE 0110/1.89 Table 1	-	-	-	
	For Rated Main Voltage <150 Vrms	-	I-IV	-	
	For Rated Main Voltage <300 Vrms	-	I-III	-	
	Climatic Classification	-	40/85/21	-	
	Pollution Degree (DIN VDE 0110/1.89)	-	2	-	
CTI	Comparative Tracking Index	175	-	-	
$V_{PR}$	Input to Output Test Voltage, Method b, $V_{IORM} \times 1.875 = V_{PR}$ , 100% Production Test with $t_m = 1$ s, Partial Discharge <5 pC	1060	-	-	
$V_{PR}$	Input to Output Test Voltage, Method a, $V_{IORM} \times 1.5 = V_{PR}$ , Type and Sample Test with $t_m = 60$ s, Partial Discharge <5 pC	848	-	-	
$V_{IORM}$	Max Working Insulation Voltage	565	-	-	$V_{peak}$
$V_{IOTM}$	Highest Allowable Over Voltage	4000	-	-	$V_{peak}$
	External Creepage	5.0	-	-	mm
	External Clearance	5.0	-	-	mm
	Insulation thickness	0.5	-	-	mm
$T_{Case}$	Safety Limit Values, Maximum Values Allowed in the Event of a Failure, Case Temperature	150	-	-	°C
$R_{IO}$	Insulation Resistance at $T_S$ , $V_{IO} = 500$ V	$10^9$	-	-	$\Omega$

# FODM452, FODM453

## MAXIMUM RATINGS ( $T_A = 25^\circ\text{C}$ unless otherwise noted)

Symbol	Parameter	Rating	Unit
$T_{\text{STG}}$	Storage Temperature	-40 to +125	$^\circ\text{C}$
$T_{\text{OPR}}$	Operating Temperature	-40 to +85	$^\circ\text{C}$

## EMITTER

$I_F$ (avg)	DC/Average Forward Input Current	25	mA
$I_F$ (pk)	Peak Forward Input Current (50% Duty Cycle, 1 ms P.W.)	50	mA
$I_F$ (trans)	Peak Transient Input Current ( $\leq 1 \mu\text{s}$ P.W., 300 pps)	1.0	A
$V_R$	Reverse Input Voltage	5	V
$P_D$	Input Power Dissipation (No Derating Required over Specified Operating Temp Range)	45	mW

## DETECTOR

$I_O$ (avg)	Average Output Current	8	mA
$I_O$ (pk)	Peak Output Current	16	mA
$V_{\text{CC}}$	Supply Voltage	-0.5 to 30	V
$V_O$	Output Voltage	-0.5 to 20	V
$P_D$	Output Power Dissipation (No Derating Required over Specified Operating Temp Range)	100	mW

Stresses exceeding those listed in the Maximum Ratings table may damage the device. If any of these limits are exceeded, device functionality should not be assumed, damage may occur and reliability may be affected.

# FODM452, FODM453

## ELECTRICAL CHARACTERISTICS ( $T_A = 0$ to $70^\circ\text{C}$ unless otherwise noted)

Symbol	Parameter	Test Condition	Device	Min	Typ*	Max	Unit
--------	-----------	----------------	--------	-----	------	-----	------

### INDIVIDUAL COMPONENT CHARACTERISTICS

EMITTER							
$V_F$	Input Forward Voltage	$I_F = 16\text{ mA}, T_A = 25^\circ\text{C}$		–	1.60	1.7	V
		$I_F = 16\text{ mA}$		–	–	1.8	
$B_{VR}$	Input Reverse Breakdown Voltage	$I_R = 10\ \mu\text{A}$		5.0	–	–	V
$\Delta V_F/\Delta T_A$	Temperature Coefficient of Forward Voltage	$I_F = 16\text{ mA}$		–	–1.8	–	mV/ $^\circ\text{C}$
DETECTOR							
$I_{OH}$	Logic High Output Current	$I_F = 0\text{ mA}, V_O = V_{CC} = 5.5\text{ V}, T_A = 25^\circ\text{C}$		–	.001	0.5	$\mu\text{A}$
		$I_F = 0\text{ mA}, V_O = V_{CC} = 15\text{ V}, T_A = 25^\circ\text{C}$		–	.001	1	
		$I_F = 0\text{ mA}, V_O = V_{CC} = 15\text{ V}$		–	–	50	
$I_{CCL}$	Logic Low Supply Current	$I_F = 16\text{ mA}, V_O = \text{Open}, V_{CC} = 15\text{ V}$		–	100	200	$\mu\text{A}$
$I_{CCH}$	Logic high Supply Current	$I_F = 0\text{ mA}, V_O = \text{Open}, V_{CC} = 15\text{ V}, T_A = 25^\circ\text{C}$		–	0.05	1	$\mu\text{A}$
		$I_F = 0\text{ mA}, V_O = \text{Open}, V_{CC} = 15\text{ V}$		–	–	2	

### TRANSFER CHARACTERISTICS

COUPLED								
CTR	Current Transfer Ratio (Note 1)	$I_F = 16\text{ mA}, V_{CC} = 4.5\text{ V}$	$T_A = 25^\circ\text{C}, V_{OL} = 0.4\text{ V}$		20	–	50	%
			$V_{OL} = 0.5\text{ V}$		15	–	–	
$V_{OL}$	Logic LOW Output Voltage	$I_F = 16\text{ mA}, I_O = 3\text{ mA}, V_{CC} = 4.5\text{ V}, T_A = 25^\circ\text{C}$		–	–	0.4	V	
		$I_F = 16\text{ mA}, I_O = 2.4\text{ mA}, V_{CC} = 4.5\text{ V}$		–	–	0.5		

### SWITCHING CHARACTERISTICS ( $V_{CC} = 5\text{ V}$ )

$T_{PHL}$	Propagation Delay Time to Logic LOW	$R_L = 1.9\text{ k}\Omega, I_F = 16\text{ mA}, T_A = 25^\circ\text{C}$ (Note 2) (Figure 9)		–	0.40	0.8	$\mu\text{s}$
		$R_L = 1.9\text{ k}\Omega, I_F = 16\text{ mA}$ (Note 2) (Figure 9)		–	–	1.0	
$T_{PLH}$	Propagation Delay Time to Logic HIGH	$R_L = 1.9\text{ k}\Omega, I_F = 16\text{ mA}, T_A = 25^\circ\text{C}$ (Note 2) (Figure 9)		–	0.35	0.8	$\mu\text{s}$
		$R_L = 1.9\text{ k}\Omega, I_F = 16\text{ mA}$ (Note 2) (Figure 9)		–	–	1.0	
$ CM_H $	Common Mode Transient Immunity at Logic HIGH	$I_F = 0\text{ mA}, V_{CM} = 10\text{ V}_{P-P}, R_L = 1.9\text{ k}\Omega, T_A = 25^\circ\text{C}$ (Note 3) (Figure 10)	FODM452	5	15	–	KV/ $\mu\text{s}$
		$I_F = 0\text{ mA}, V_{CM} = 1500\text{ V}_{P-P}, R_L = 1.9\text{ k}\Omega, T_A = 25^\circ\text{C}$ (Note 3) (Figure 10)	FODM453	15	40	–	
$ CM_L $	Common Mode Transient Immunity at Logic LOW	$I_F = 16\text{ mA}, V_{CM} = 10\text{ V}_{P-P}, R_L = 1.9\text{ k}\Omega, T_A = 25^\circ\text{C}$ (Note 3) (Figure 10)	FODM452	5	15	–	KV/ $\mu\text{s}$
		$I_F = 16\text{ mA}, V_{CM} = 1500\text{ V}_{P-P}, R_L = 1.9\text{ k}\Omega, T_A = 25^\circ\text{C}$ (Note 3) (Figure 10)	FODM453	15	40	–	
BW	Bandwidth	$R_L = 100\ \Omega$		–	3	–	MHz

### ISOLATION CHARACTERISTICS

$V_{ISO}$	Withstand Insulation Test Voltage	$RH \leq 50\%, T_A = 25^\circ\text{C}, t = 1\text{ min.}$ (Note 4)		3750	–	–	$V_{RMS}$
$C_{I-O}$	Capacitance (Input to Output)	$f = 1\text{ MHz}$ (Note 4)		–	0.2	–	pF

Product parametric performance is indicated in the Electrical Characteristics for the listed test conditions, unless otherwise noted. Product performance may not be indicated by the Electrical Characteristics if operated under different conditions.

\*All Typical at  $T_A = 25^\circ\text{C}$

- Current Transfer Ratio is defined as a ratio of output collector current,  $I_O$ , to the forward LED input current,  $I_F$ , times 100%.
- The 1.9 k $\Omega$  load represents 1 TTL unit load of 1.6 mA and 5.6 k $\Omega$  pull-up resistor.
- Common mode transient immunity in logic high level is the maximum tolerable (positive)  $dV_{cm}/dt$  on the leading edge of the common mode pulse signal  $V_{CM}$ , to assure that the output will remain in a logic high state (i.e.,  $V_O > 2.0\text{ V}$ ). Common mode transient immunity in logic low level is the maximum tolerable (negative)  $dV_{cm}/dt$  on the trailing edge of the common mode pulse signal,  $V_{CM}$ , to assure that the output will remain in a logic low state (i.e.,  $V_O < 0.8\text{ V}$ ).
- Device is considered a two terminal device: Pins 1, and 3 are shorted together and Pins 4, 5, and 6 are shorted together.

TYPICAL PERFORMANCE CURVES

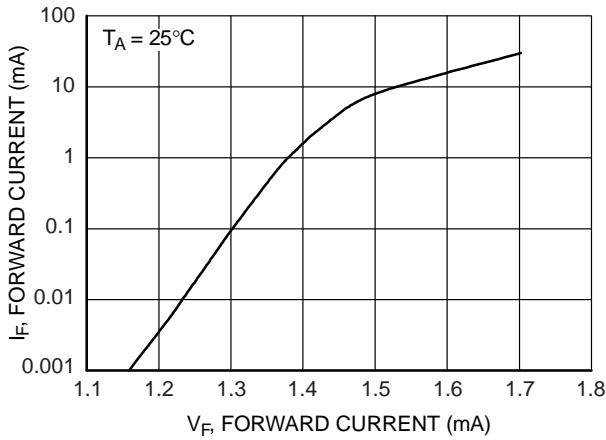

Figure 1. Input Forward Current vs Forward Voltage

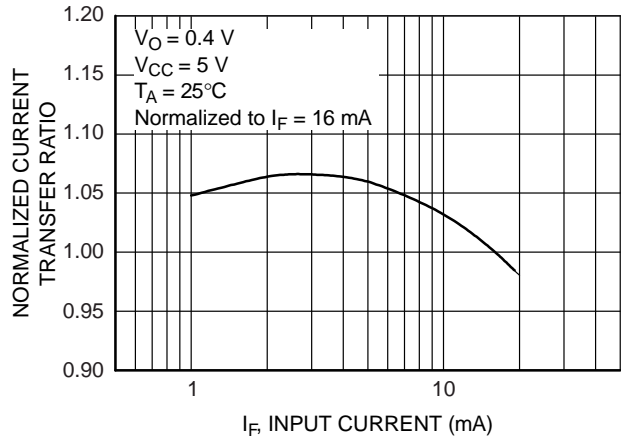

Figure 2. Normalized Current Transfer Ratio vs. Input Current

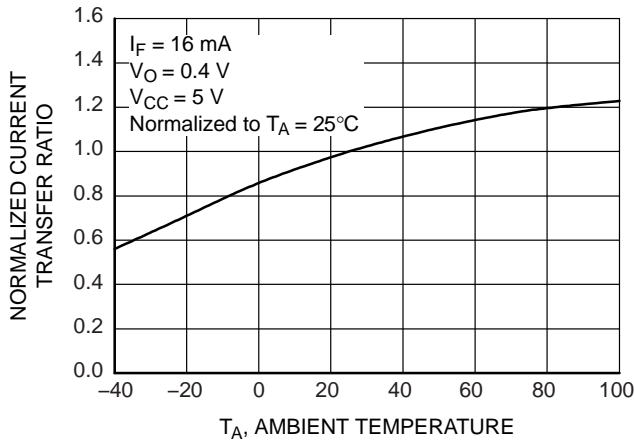

Figure 3. Normalized Current Transfer Ratio vs. Ambient Temperature

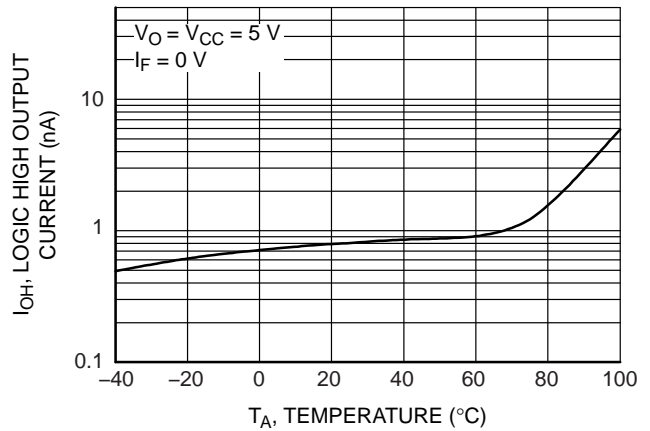

Figure 4. Logic High Output Current vs. Ambient Temperature

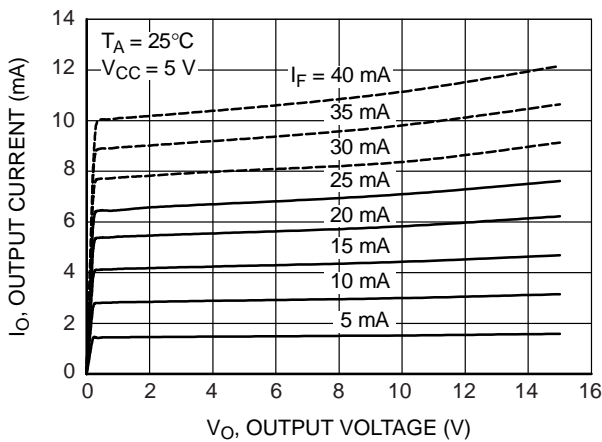

Figure 5. DC and Pulsed Transfer Characteristics

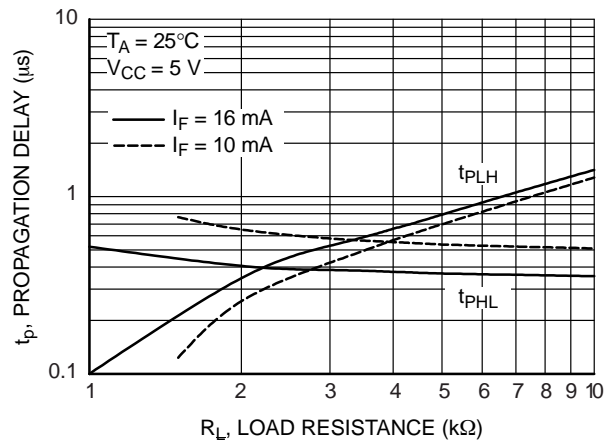

Figure 6. Propagation Delay vs. Load Resistance

# FODM452, FODM453

## TYPICAL PERFORMANCE CURVES (Continued)

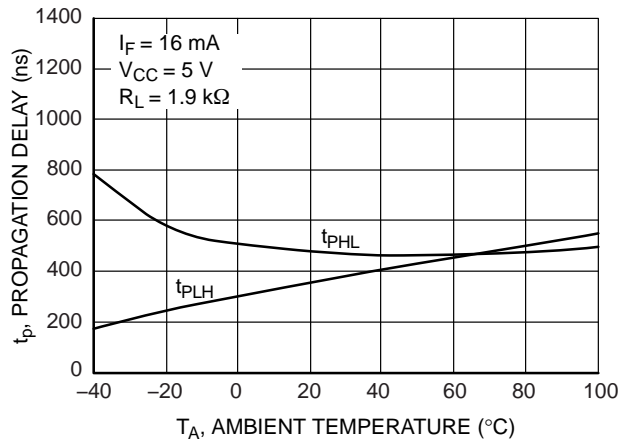

Figure 7. Propagation Delay vs. Ambient Temperature

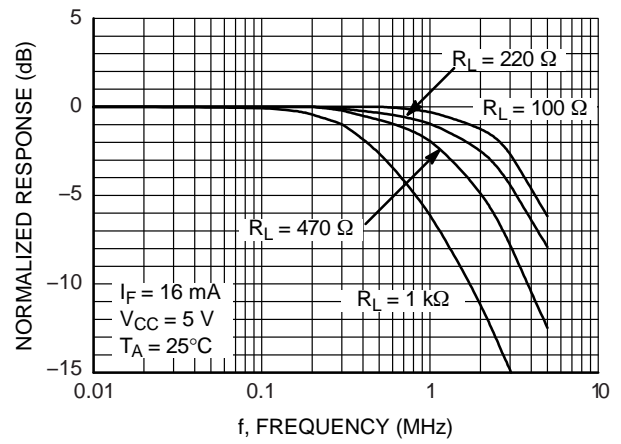

Figure 8. Frequency Response

# FODM452, FODM453

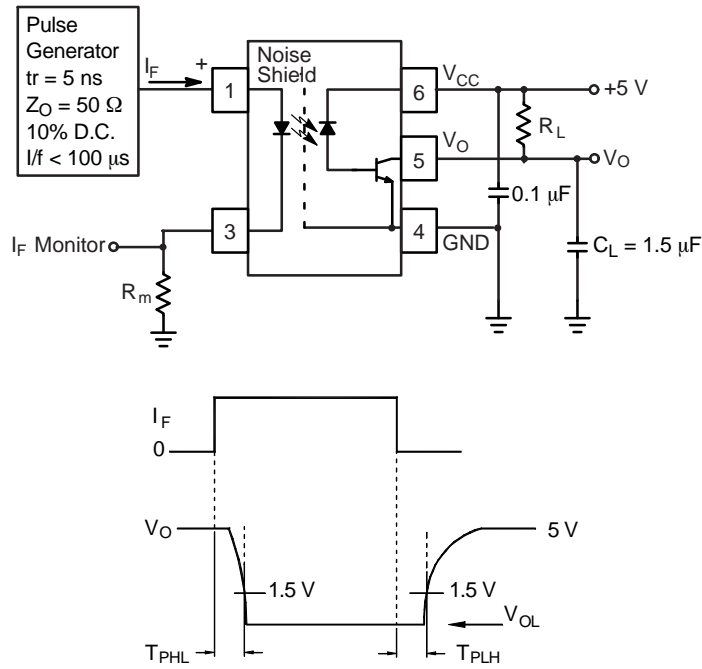

Figure 9. Switching Time Test Circuit

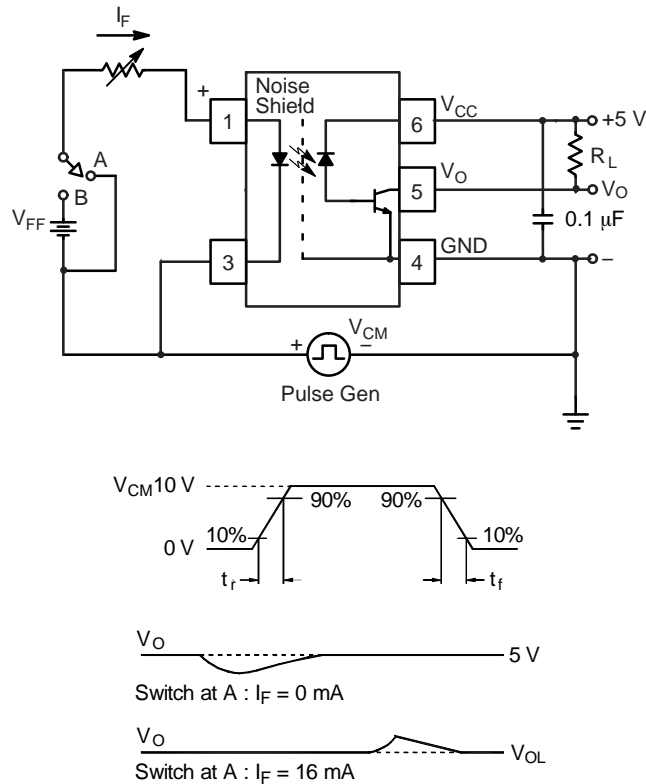

Figure 10. Common Mode Immunity Test Circuit

# FODM452, FODM453

## FOOTPRINT DRAWING FOR PCB LAYOUT

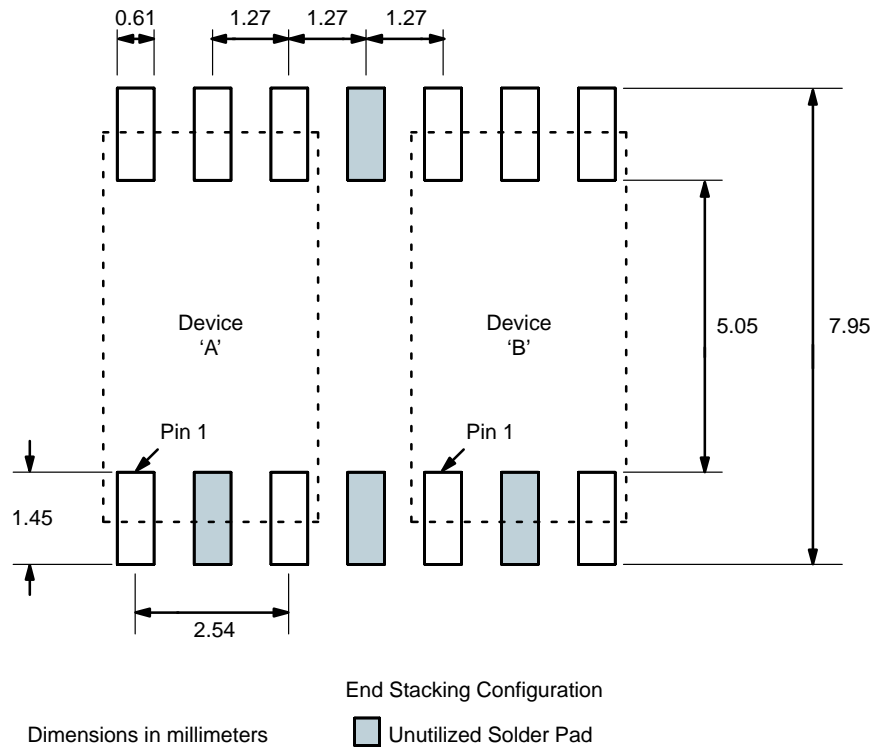

Figure 11. Footprint Drawing for PCB Layout

# FODM452, FODM453

## REFLOW PROFILE

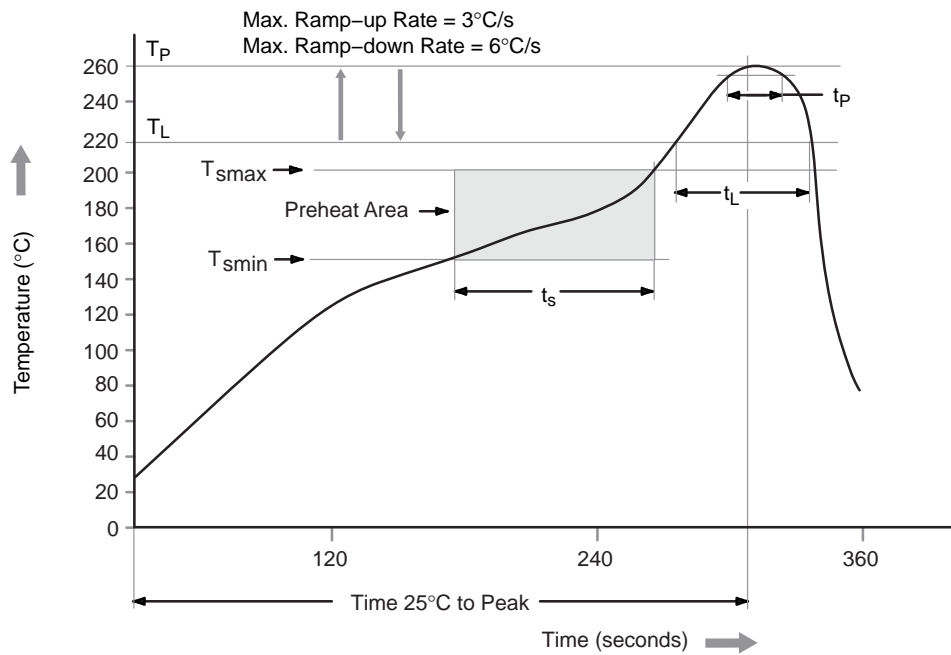

Figure 12. Reflow Profile

Table 1. REFLOW PROFILE

Profile Feature	Pb-Free Assembly Profile
Temperature Minimum ( $T_{smin}$ )	150°C
Temperature Maximum ( $T_{smax}$ )	200°C
Time ( $t_s$ ) from ( $T_{smin}$ to $T_{smax}$ )	60 – 120 seconds
Ramp-up Rate ( $t_L$ to $t_p$ )	3°C/second max.
Liquidous Temperature ( $T_L$ )	217°C
Time ( $t_L$ ) Maintained Above ( $T_L$ )	60 – 150 seconds
Peak Body Package Temperature	260°C +0°C / -5°C
Time ( $t_p$ ) within 5°C of 260°C	30 seconds
Ramp-down Rate ( $T_P$ to $T_L$ )	6°C/second max.
Time 25°C to Peak Temperature	8 minutes max.

## FODM452, FODM453

### ORDERING INFORMATION

Part Number	Package	Shipping†
FODM452	MFP5 4.1X4.4, 2.54P (Pb-Free)	100 Units / Tube
FODM452R2	MFP5 4.1X4.4, 2.54P (Pb-Free)	2500 / Tape & Reel
FODM452V	MFP5 4.1X4.4, 2.54P IEC60747-5-2 (Pb-Free)	100 Units / Tube
FODM452R2V	MFP5 4.1X4.4, 2.54P IEC60747-5-2 (Pb-Free)	2500 / Tape & Reel
FODM453	MFP5 4.1X4.4, 2.54P (Pb-Free)	100 Units / Tube
FODM453R2	MFP5 4.1X4.4, 2.54P (Pb-Free)	2500 / Tape & Reel
FODM453V	MFP5 4.1X4.4, 2.54P IEC60747-5-2 (Pb-Free)	100 Units / Tube
FODM453R2V	MFP5 4.1X4.4, 2.54P IEC60747-5-2 (Pb-Free)	2500 / Tape & Reel

†For information on tape and reel specifications, including part orientation and tape sizes, please refer to our Tape and Reel Packaging Specifications Brochure, BRD8011/D.

**MECHANICAL CASE OUTLINE**  
**PACKAGE DIMENSIONS**

MFP5 4.1X4.4, 2.54P  
CASE 100AM  
ISSUE 0

DATE 31 AUG 2016

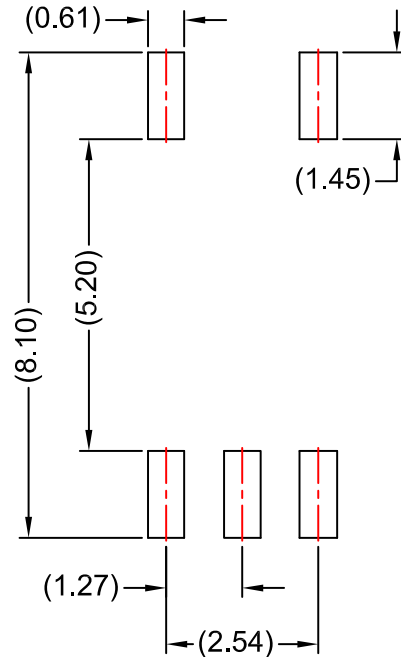
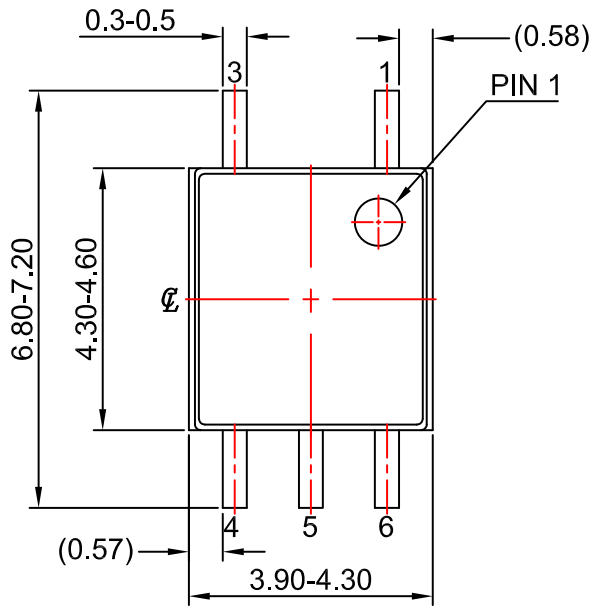

**LAND PATTERN RECOMMENDATION**

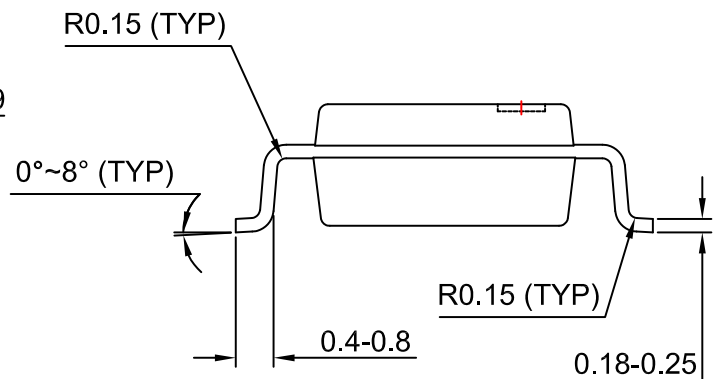
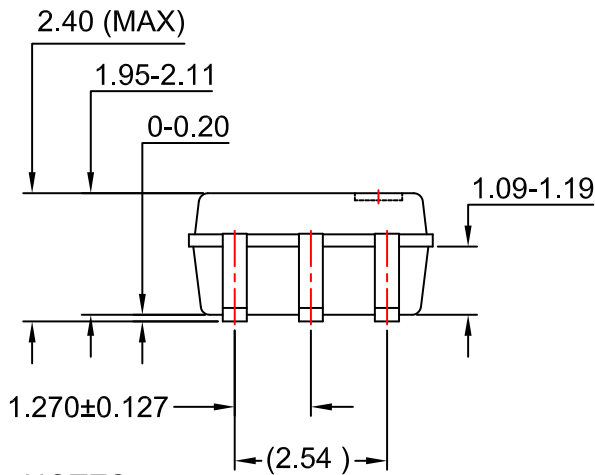

**NOTES:**

- A) NO STANDARD APPLIES TO THIS PACKAGE
- B) ALL DIMENSIONS ARE IN MILLIMETERS.
- C) DIMENSIONS ARE EXCLUSIVE OF BURRS, MOLD FLASH, AND TIE BAR EXTRUSION

<b>DOCUMENT NUMBER:</b>	<b>98AON13486G</b>	Electronic versions are uncontrolled except when accessed directly from the Document Repository. Printed versions are uncontrolled except when stamped "CONTROLLED COPY" in red.
<b>DESCRIPTION:</b>	<b>MFP5 4.1X4.4, 2.54P</b>	<b>PAGE 1 OF 1</b>

ON Semiconductor and **ON** are trademarks of Semiconductor Components Industries, LLC dba ON Semiconductor or its subsidiaries in the United States and/or other countries. ON Semiconductor reserves the right to make changes without further notice to any products herein. ON Semiconductor makes no warranty, representation or guarantee regarding the suitability of its products for any particular purpose, nor does ON Semiconductor assume any liability arising out of the application or use of any product or circuit, and specifically disclaims any and all liability, including without limitation special, consequential or incidental damages. ON Semiconductor does not convey any license under its patent rights nor the rights of others.

**onsemi**, **Onsemi**, and other names, marks, and brands are registered and/or common law trademarks of Semiconductor Components Industries, LLC dba "**onsemi**" or its affiliates and/or subsidiaries in the United States and/or other countries. **onsemi** owns the rights to a number of patents, trademarks, copyrights, trade secrets, and other intellectual property. A listing of **onsemi**'s product/patent coverage may be accessed at [www.onsemi.com/site/pdf/Patent-Marking.pdf](http://www.onsemi.com/site/pdf/Patent-Marking.pdf). **onsemi** reserves the right to make changes at any time to any products or information herein, without notice. The information herein is provided "as-is" and **onsemi** makes no warranty, representation or guarantee regarding the accuracy of the information, product features, availability, functionality, or suitability of its products for any particular purpose, nor does **onsemi** assume any liability arising out of the application or use of any product or circuit, and specifically disclaims any and all liability, including without limitation special, consequential or incidental damages. Buyer is responsible for its products and applications using **onsemi** products, including compliance with all laws, regulations and safety requirements or standards, regardless of any support or applications information provided by **onsemi**. "Typical" parameters which may be provided in **onsemi** data sheets and/or specifications can and do vary in different applications and actual performance may vary over time. All operating parameters, including "Typicals" must be validated for each customer application by customer's technical experts. **onsemi** does not convey any license under any of its intellectual property rights nor the rights of others. **onsemi** products are not designed, intended, or authorized for use as a critical component in life support systems or any FDA Class 3 medical devices or medical devices with a same or similar classification in a foreign jurisdiction or any devices intended for implantation in the human body. Should Buyer purchase or use **onsemi** products for any such unintended or unauthorized application, Buyer shall indemnify and hold **onsemi** and its officers, employees, subsidiaries, affiliates, and distributors harmless against all claims, costs, damages, and expenses, and reasonable attorney fees arising out of, directly or indirectly, any claim of personal injury or death associated with such unintended or unauthorized use, even if such claim alleges that **onsemi** was negligent regarding the design or manufacture of the part. **onsemi** is an Equal Opportunity/Affirmative Action Employer. This literature is subject to all applicable copyright laws and is not for resale in any manner.

## ADDITIONAL INFORMATION

### TECHNICAL PUBLICATIONS:

Technical Library: [www.onsemi.com/design/resources/technical-documentation](http://www.onsemi.com/design/resources/technical-documentation)  
onsemi Website: [www.onsemi.com](http://www.onsemi.com)

### ONLINE SUPPORT: [www.onsemi.com/support](http://www.onsemi.com/support)

For additional information, please contact your local Sales Representative at [www.onsemi.com/support/sales](http://www.onsemi.com/support/sales)



## Looking for pricing, stock, or lifecycle information?

Click below to explore more details on WIN SOURCE:

-  [View FODM452R1V on WIN SOURCE](#)
-  [Fairchild/ON Semiconductor Information](#)

## Optimize Your Supply Chain with WIN SOURCE Solutions

-  Global Sourcing Solution
-  Obsolete Management
-  Cost Control Management
-  Shortage Management
-  Alternative Solution
-  Excess Inventory Management