



THE DATASHEET OF FSFR2100XSL



Power Switch for Half-Bridge Resonant Converters

FSFR-XS Series

Description

The FSFR-XS series includes highly integrated power switches designed for high-efficiency half-bridge resonant converters. Offering everything necessary to build a reliable and robust resonant converter, the FSFR-XS series simplifies designs while improving productivity and performance. The FSFR-XS series combines power MOSFETs with fast-recovery type body diodes, a high-side gate-drive circuit, an accurate current controlled oscillator, frequency limit circuit, soft-start, and built-in protection functions. The high-side gate-drive circuit has common-mode noise cancellation capability, which guarantees stable operation with excellent noise immunity. The fast-recovery body diode of the MOSFETs improves reliability against abnormal operation conditions, while minimizing the effect of reverse recovery. Using the zero-voltage-switching (ZVS) technique dramatically reduces the switching losses and significantly improves efficiency. The ZVS also reduces the switching noise noticeably, which allows a small-sized Electromagnetic Interference (EMI) filter.

The FSFR-XS series can be applied to resonant converter topologies such as series resonant, parallel resonant, and LLC resonant converters.

Features

- Variable Frequency Control with 50% Duty Cycle for Half-Bridge Resonant Converter Topology
- High Efficiency through Zero Voltage Switching (ZVS)
- Internal UniFET™ with Fast-Recovery Body Diode
- Fixed Dead Time (350 ns) Optimized for MOSFETs
- Up to 300 kHz Operating Frequency
- Auto-Restart Operation for All Protections with External LV_{CC}
- Protection Functions: Over-Voltage Protection (OVP), Over-Current Protection (OCP), Abnormal Over-Current Protection (AOCP), Internal Thermal Shutdown (TSD)

Applications

- PDP and LCD TVs
- Desktop PCs and Servers
- Adapters
- Telecom Power Supplies

Related Resources

[AN-4151](#) – Half-Bridge LLC Resonant Converter Design Using FSFR-Series Power Switch

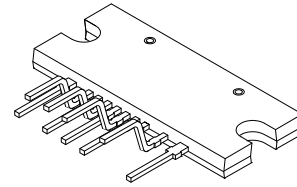

SIP9 26x10.5
CASE 127EM

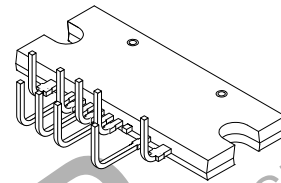

SIP9 26x10.5
CASE 127EN

MARKING DIAGRAM

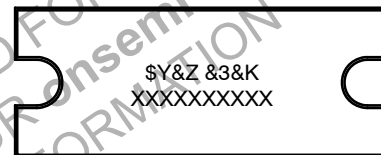

- \$Y = onsemi Logo
- &Z = Assembly Plant Code
- &3 = 3-Digit Date Code
- &K = 2-Digits Lot Run Traceability Code
- XXXXXXXXXX = Device Code

ORDERING INFORMATION

See detailed ordering and shipping information on page 2 of this data sheet.

FSFR-XS Series

ORDERING INFORMATION

Part Number	Package	Operating Junction Temperature	$R_{DS(ON_MAX)}$	Maximum Output Power without Heatsink ($V_{IN} = 350\sim 400\text{ V}$) (Note 1, 2)	Maximum Output Power with Heatsink ($V_{IN} = 350\sim 400\text{ V}$) (Note 1, 2)
FSFR2100XS	9-SIP	-40 to +130°C	0.51 Ω	180 W	400 W
FSFR1800XS			0.95 Ω	120 W	260 W
FSFR1700XS			1.25 Ω	100 W	200 W
FSFR1600XS			1.55 Ω	80 W	160 W
FSFR2100XSL	9-SIP L-Forming		0.51 Ω	180 W	400 W
FSFR1800XSL			0.95 Ω	120 W	260 W
FSFR1700XSL			1.25 Ω	100 W	200 W
FSFR1600XSL			1.55 Ω	80 W	160 W

1. The junction temperature can limit the maximum output power.
2. Maximum practical continuous power in an open-frame design at 50°C ambient.

APPLICATION CIRCUIT DIAGRAM

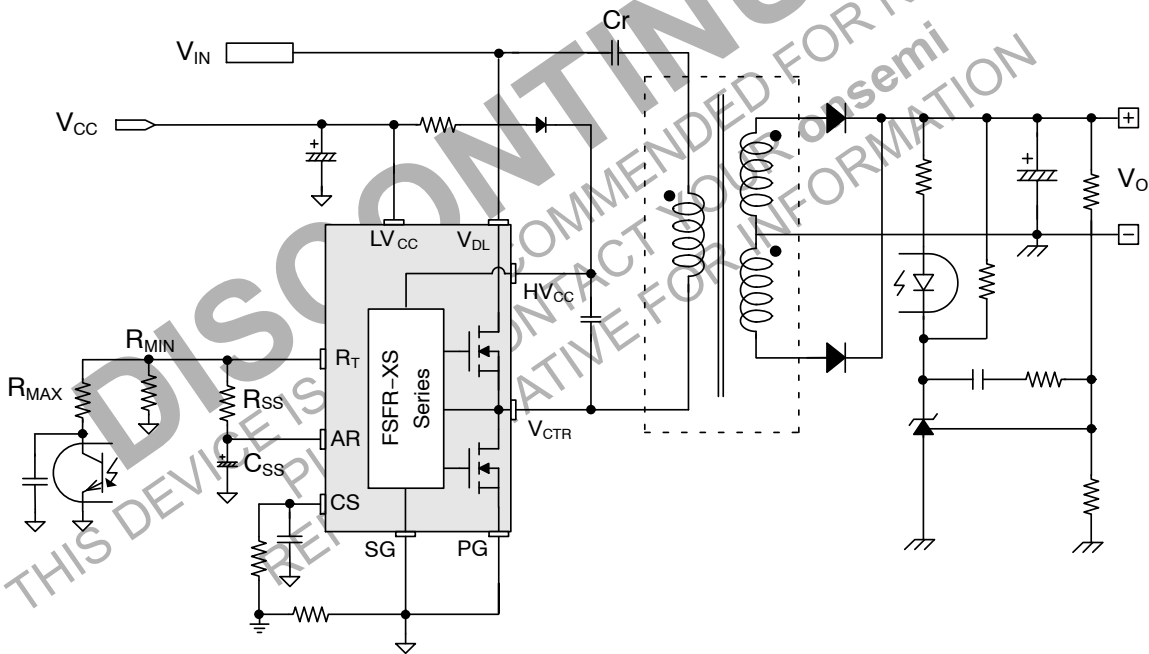

Figure 1. Typical Application Circuit (LLC Resonant Half-Bridge Converter)

FSFR-XS Series

BLOCK DIAGRAM

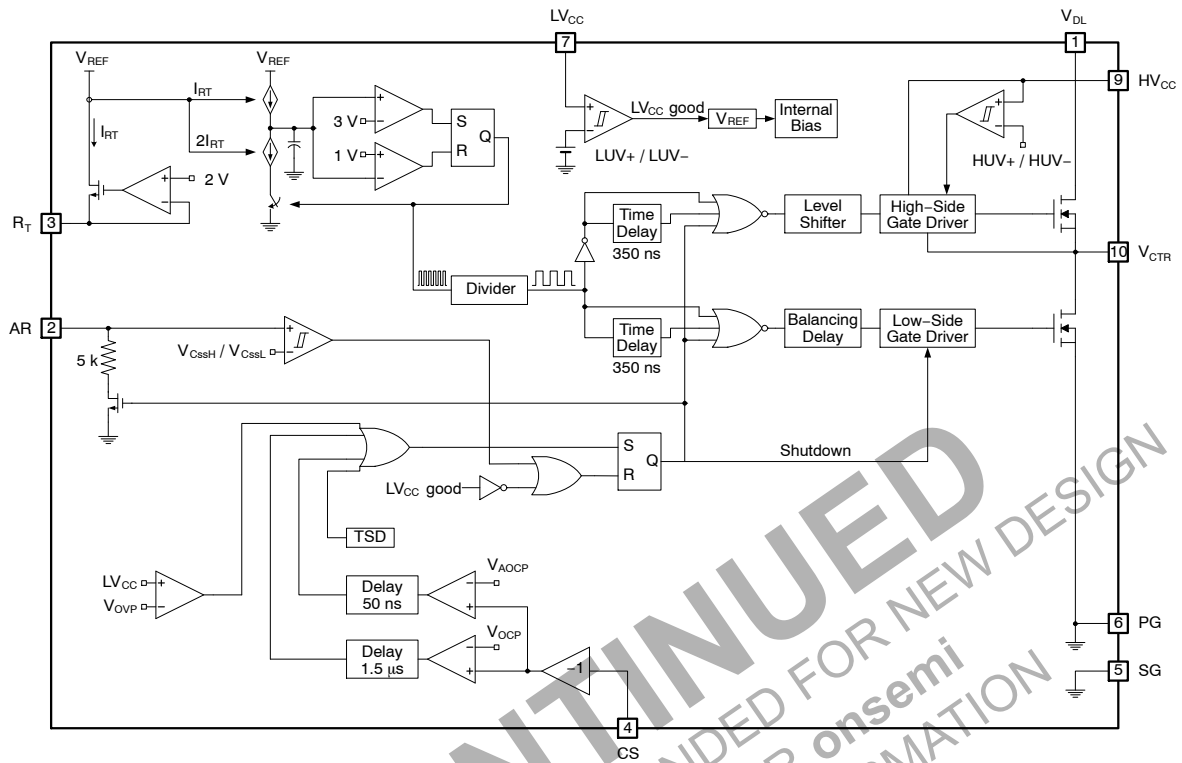

Figure 2. Internal Block Diagram

DISCONTINUED
 THIS DEVICE IS NOT RECOMMENDED FOR NEW DESIGN
 PLEASE CONTACT YOUR onsemi
 REPRESENTATIVE FOR INFORMATION

FSFR–XS Series

PIN CONFIGURATION

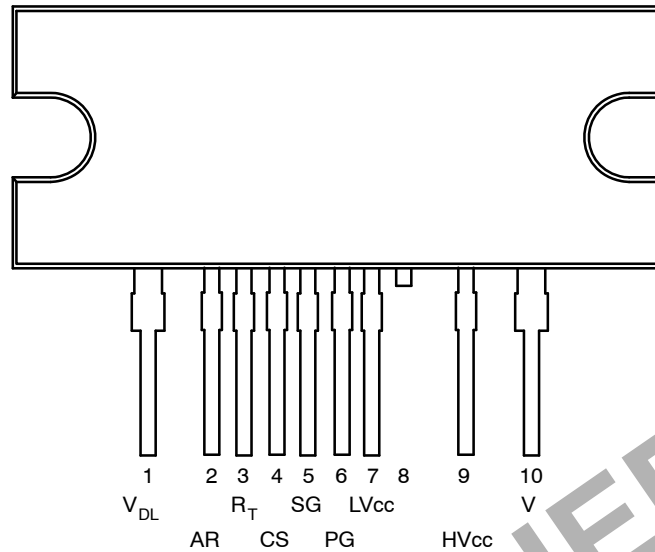

Figure 3. Package Diagram

PIN DESCRIPTION

Pin #	Name	Description
1	V _{DL}	This is the drain of the high-side MOSFET, typically connected to the input DC link voltage.
2	AR	This pin is for discharging the external soft-start capacitor when any protections are triggered. When the voltage of this pin drops to 0.2 V, all protections are reset and the controller starts to operate again.
3	R _T	This pin programs the switching frequency. Typically, an opto-coupler is connected to control the switching frequency for the output voltage regulation.
4	CS	This pin senses the current flowing through the low-side MOSFET. Typically, negative voltage is applied on this pin.
5	SG	This pin is the control ground.
6	PG	This pin is the power ground. This pin is connected to the source of the low-side MOSFET.
7	LV _{CC}	This pin is the supply voltage of the control IC.
8	NC	No connection.
9	HV _{CC}	This is the supply voltage of the high-side gate-drive circuit IC.
10	V _{CTR}	This is the drain of the low-side MOSFET. Typically, a transformer is connected to this pin.

FSFR-XS Series

ABSOLUTE MAXIMUM RATINGS (T_A = 25°C unless otherwise specified)

Symbol	Parameter	Min	Max	Unit	
V _{DS}	Maximum Drain-to-Source Voltage (V _{DL} -V _{CTR} and V _{CTR} -PG)	500	-	V	
LV _{CC}	Low-Side Supply Voltage	-0.3	25.0	V	
HV _{CC} to V _{CTR}	High-Side V _{CC} Pin to Low-Side Drain Voltage	-0.3	25.0	V	
HV _{CC}	High-Side Floating Supply Voltage	-0.3	525.0	V	
V _{AR}	Auto-Restart Pin Input Voltage	-0.3	LV _{CC}	V	
V _{CS}	Current-Sense (CS) Pin Input Voltage	-5.0	1.0	V	
V _{RT}	R _T Pin Input Voltage	-0.3	5.0	V	
dV _{CTR} /dt	Allowable Low-Side MOSFET Drain Voltage Slew Rate	-	50	V/ns	
P _D	Total Power Dissipation (Note 3)	FSFR2100XS/L	-	12.0	W
		FSFR1800XS/L	-	11.7	
		FSFR1700XS/L	-	11.6	
		FSFR1600XS/L	-	11.5	
T _J	Maximum Junction Temperature (Note 4)	-	+150	°C	
	Recommended Operating Junction Temperature (Note 4)	-40	+130		
T _{STG}	Storage Temperature Range	-55	+150	°C	

MOSFET SECTION

V _{DGR}	Drain Gate Voltage (R _{GS} = 1 MΩ)	500	-	V		
V _{GS}	Gate Source (GND) Voltage	-	±30	V		
I _{DM}	Drain Current Pulsed (Note 5)	FSFR2100XS/L	-	32	A	
		FSFR1800XS/L	-	23		
		FSFR1700XS/L	-	20		
		FSFR1600XS/L	-	18		
I _D	Continuous Drain Current	FSFR2100XS/L	T _C = 25°C	-	10.5	A
			T _C = 100°C	-	6.5	
		FSFR1800XS/L	T _C = 25°C	-	7.0	
			T _C = 100°C	-	4.5	
		FSFR1700XS/L	T _C = 25°C	-	6.0	
			T _C = 100°C	-	3.9	
		FSFR1600XS/L	T _C = 25°C	-	4.5	
			T _C = 100°C	-	2.7	

PACKAGE SECTION

Torque	Recommended Screw Torque	5~7	kgf·cm
--------	--------------------------	-----	--------

Stresses exceeding those listed in the Maximum Ratings table may damage the device. If any of these limits are exceeded, device functionality should not be assumed, damage may occur and reliability may be affected.

3. Per MOSFET when both MOSFETs are conducting.

4. The maximum value of the recommended operating junction temperature is limited by thermal shutdown.

5. Pulse width is limited by maximum junction temperature.

FSFR-XS Series

THERMAL IMPEDANCE ($T_A = 25^\circ\text{C}$ unless otherwise specified)

Symbol	Parameter	Value	Unit
θ_{JC}	Junction-to-Case Center Thermal Impedance (Both MOSFETs Conducting)	FSFR2100XS/L	10.44
		FSFR1800XS/L	10.68
		FSFR1700XS/L	10.79
		FSFR1600XS/L	10.89
θ_{JA}	Junction-to-Ambient Thermal Impedance	FSFR XS Series	80

ELECTRICAL CHARACTERISTICS ($T_A = 25^\circ\text{C}$ unless otherwise noted)

Symbol	Parameter	Test Condition	Min	Typ	Max	Unit
--------	-----------	----------------	-----	-----	-----	------

MOSFET SECTION

BV_{DSS}	Drain-to-Source Breakdown Voltage		$I_D = 200 \mu\text{A}, T_A = 25^\circ\text{C}$	500	-	-	V
			$I_D = 200 \mu\text{A}, T_A = 125^\circ\text{C}$	-	540	-	
$R_{DS(ON)}$	On-State Resistance	FSFR2100XS/L	$V_{GS} = 10 \text{ V}, I_D = 6.0 \text{ A}$	-	0.41	0.51	Ω
		FSFR1800XS/L	$V_{GS} = 10 \text{ V}, I_D = 3.0 \text{ A}$	-	0.77	0.95	
		FSFR1700XS/L	$V_{GS} = 10 \text{ V}, I_D = 2.0 \text{ A}$	-	1.00	1.25	
		FSFR1600XS/L	$V_{GS} = 10 \text{ V}, I_D = 2.25 \text{ A}$	-	1.25	1.55	
t_{rr}	Body Diode Reverse Recovery Time (Note 6)	FSFR2100XS/L	$V_{GS} = 0 \text{ V}, I_{Diode} = 10.5 \text{ A}, dI_{Diode}/dt = 100 \text{ A}/\mu\text{s}$	-	120	-	ns
		FSFR1800XS/L	$V_{GS} = 0 \text{ V}, I_{Diode} = 7.0 \text{ A}, dI_{Diode}/dt = 100 \text{ A}/\mu\text{s}$	-	160	-	
		FSFR1700XS/L	$V_{GS} = 0 \text{ V}, I_{Diode} = 6.0 \text{ A}, dI_{Diode}/dt = 100 \text{ A}/\mu\text{s}$	-	160	-	
		FSFR1600XS/L	$V_{GS} = 0 \text{ V}, I_{Diode} = 4.5 \text{ A}, dI_{Diode}/dt = 100 \text{ A}/\mu\text{s}$	-	90	-	
C_{ISS}	Input Capacitance (Note 6)	FSFR2100XS/L	$V_{DS} = 25 \text{ V}, V_{GS} = 0 \text{ V}, f = 1.0 \text{ MHz}$	-	1175	-	pF
		FSFR1800XS/L		-	639	-	pF
		FSFR1700XS/L		-	512	-	pF
		FSFR1600XS/L		-	412	-	pF
C_{OSS}	Output Capacitance (Note 6)	FSFR2100XS/L	$V_{DS} = 25 \text{ V}, V_{GS} = 0 \text{ V}, f = 1.0 \text{ MHz}$	-	155	-	pF
		FSFR1800XS/L		-	82.1	-	pF
		FSFR1700XS/L		-	66.5	-	pF
		FSFR1600XS/L		-	52.7	-	pF

SUPPLY SECTION

I_{LK}	Offset Supply Leakage Current	$HV_{CC} = V_{CTR} = 500 \text{ V}$	-	-	50	μA
I_{QHCC}	Quiescent HV_{CC} Supply Current	$(HV_{CC}UV+) - 0.1 \text{ V}$	-	50	120	μA
I_{QLVCC}	Quiescent LV_{CC} Supply Current	$(LV_{CC}UV+) - 0.1 \text{ V}$	-	100	200	μA
I_{OHCC}	Operating HV_{CC} Supply Current (RMS Value)	$f_{OSC} = 100 \text{ kHz}$	-	6	9	mA
		No Switching	-	100	200	μA
I_{OLVCC}	Operating LV_{CC} Supply Current (RMS Value)	$f_{OSC} = 100 \text{ kHz}$	-	7	11	mA
		No Switching	-	2	4	mA

FSFR-XS Series

ELECTRICAL CHARACTERISTICS ($T_A = 25^\circ\text{C}$ unless otherwise noted) (continued)

Symbol	Parameter	Test Condition	Min	Typ	Max	Unit
--------	-----------	----------------	-----	-----	-----	------

UVLO SECTION

LV _{CC} UV+	LV _{CC} Supply Under-Voltage Positive Going Threshold (LV _{CC} Start)		11.2	12.5	13.8	V
LV _{CC} UV-	LV _{CC} Supply Under-Voltage Negative Going Threshold (LV _{CC} Stop)		8.9	10.0	11.1	V
LV _{CC} UVH	LV _{CC} Supply Under-Voltage Hysteresis		-	2.50	-	V
HV _{CC} UV+	HV _{CC} Supply Under-Voltage Positive Going Threshold (HV _{CC} Start)		8.2	9.2	10.2	V
HV _{CC} UV-	HV _{CC} Supply Under-Voltage Negative Going Threshold (HV _{CC} Stop)		7.8	8.7	9.6	V
HV _{CC} UVH	HV _{CC} Supply Under-Voltage Hysteresis		-	0.5	-	V

OSCILLATOR & FEEDBACK SECTION

V _{RT}	V-I Converter Threshold Voltage	R _T = 5.2 kΩ	1.5	2.0	2.5	V
f _{OSC}	Output Oscillation Frequency		94	100	106	kHz
DC	Output Duty Cycle		48	50	52	%
f _{SS}	Internal Soft-Start Initial Frequency	f _{SS} = f _{OSC} + 40 kHz, R _T = 5.2 kΩ	-	140	-	kHz
t _{SS}	Internal Soft-Start Time		2	3	4	ms

PROTECTION SECTION

V _{CSSH}	Beginning Voltage to Discharge C _{SS}		0.9	1.0	1.1	V
V _{CSSL}	Beginning Voltage to Charge C _{SS} and Restart		0.16	0.20	0.24	V
V _{OVP}	LV _{CC} Over-Voltage Protection	LV _{CC} > 21 V	21	23	25	V
V _{AOCP}	AOCP Threshold Voltage		-1.0	-0.9	-0.8	V
t _{BAO}	AOCP Blanking Time (Note 6)	V _{CS} < V _{AOCP}		50	-	ns
V _{OCP}	OCP Threshold Voltage		-0.64	-0.58	-0.52	V
t _{BO}	OCP Blanking Time (Note 6)	V _{CS} < V _{OCP}	1.0	1.5	2.0	μs
t _{DA}	Delay Time (Low Side) Detecting from V _{AOCP} to Switch Off (Note 6)		-	250	400	ns
T _{SD}	Thermal Shutdown Temperature (Note 6)		120	135	150	°C

DEAD-TIME CONTROL SECTION

D _T	Dead Time (Note 7)		-	350	-	ns
----------------	--------------------	--	---	-----	---	----

Product parametric performance is indicated in the Electrical Characteristics for the listed test conditions, unless otherwise noted. Product performance may not be indicated by the Electrical Characteristics if operated under different conditions.

6. This parameter, although guaranteed, is not tested in production.

7. These parameters, although guaranteed, are tested only in EDS (wafer test) process.

FSFR-XS Series

TYPICAL PERFORMANCE CHARACTERISTICS

(These characteristic graphs are normalized at $T_A = 25^\circ\text{C}$)

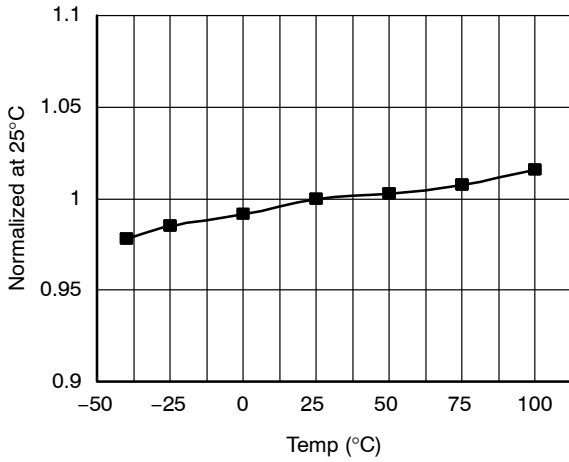

Figure 4. Low-Side MOSFET Duty Cycle vs. Temperature

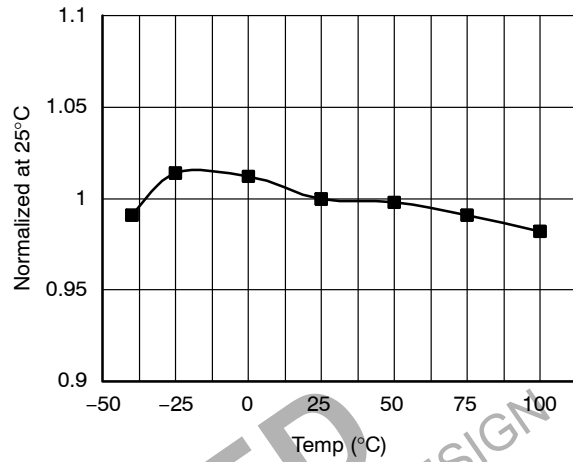

Figure 5. Switching Frequency vs. Temperature

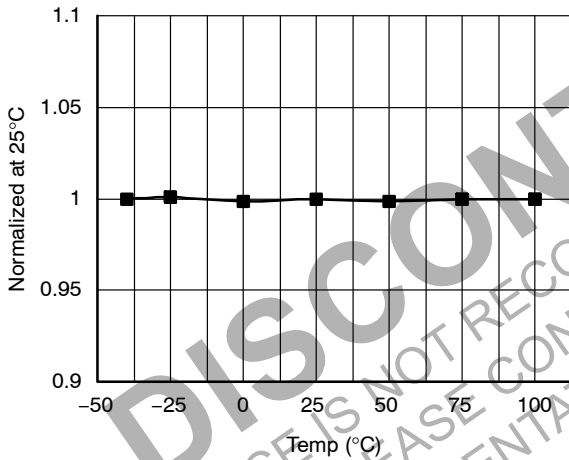

Figure 6. High-Side V_{CC} (HV_{CC}) Start vs. Temperature

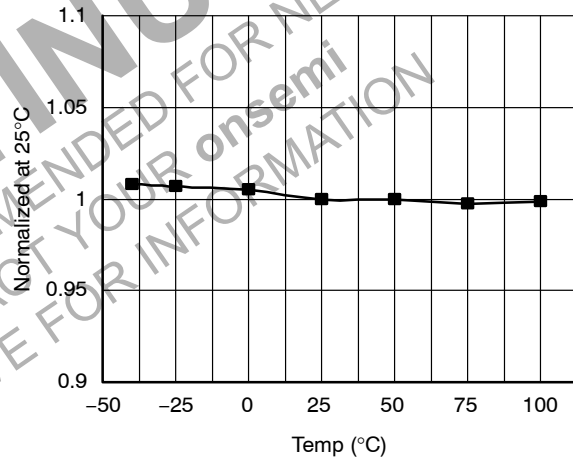

Figure 7. High-Side V_{CC} (HV_{CC}) Stop vs. Temperature

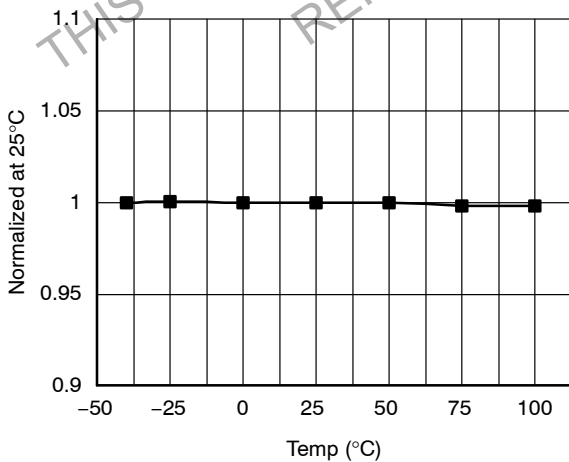

Figure 8. Low-Side V_{CC} (LV_{CC}) Start vs. Temperature

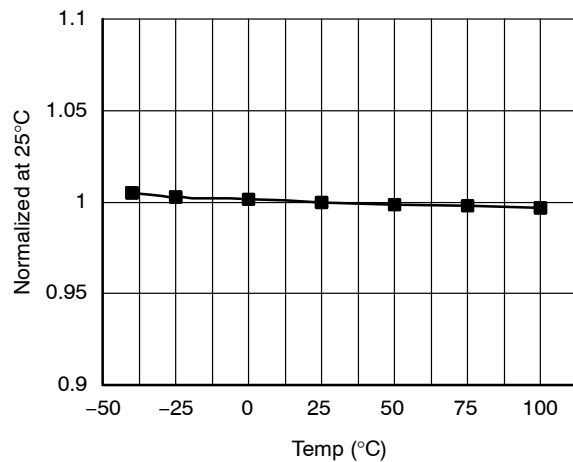

Figure 9. Low-Side V_{CC} (LV_{CC}) Stop vs. Temperature

FSFR-XS Series

TYPICAL PERFORMANCE CHARACTERISTICS (continued)

(These characteristic graphs are normalized at $T_A = 25^\circ\text{C}$)

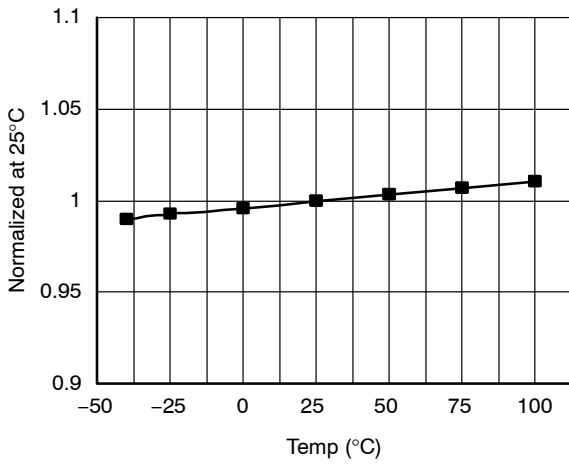

Figure 10. V_{LVCC} OVP Voltage vs. Temperature

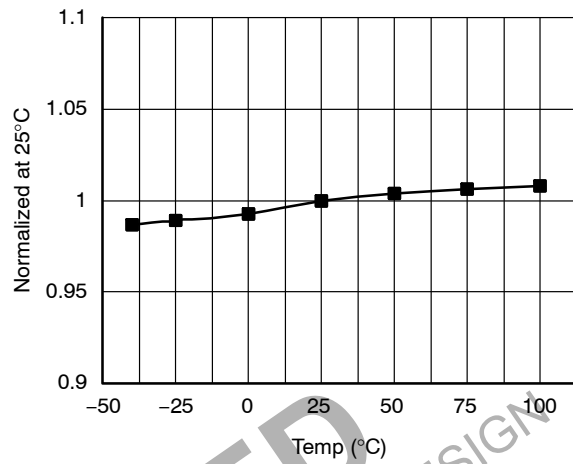

Figure 11. R_T Voltage vs. Temperature

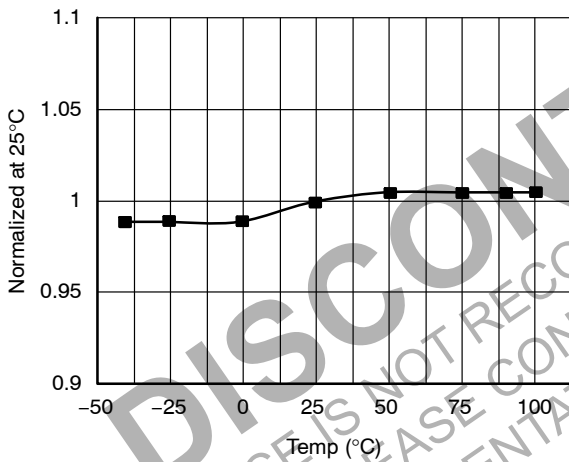

Figure 12. $V_{C_{SS}L}$ vs. Temperature

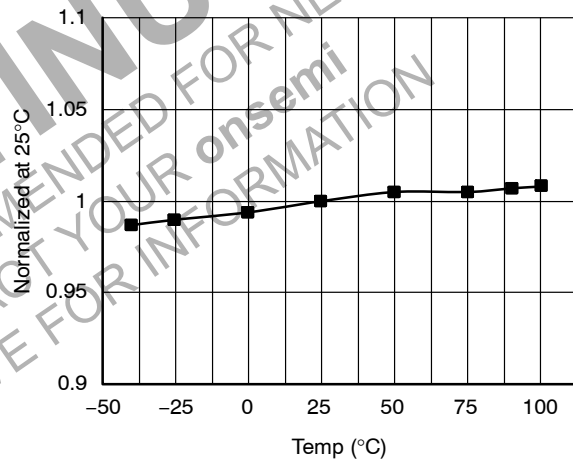

Figure 13. $V_{C_{SS}H}$ vs. Temperature

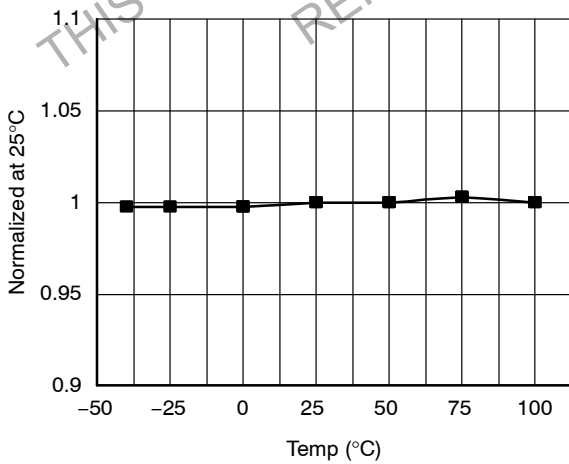

Figure 14. OCP Voltage vs. Temperature

FUNCTIONAL DESCRIPTION

Basic Operation

FSFR-XS series is designed to drive high-side and low-side MOSFETs complementarily with 50% duty cycle. A fixed dead time of 350 ns is introduced between consecutive transitions, as shown in Figure 15.

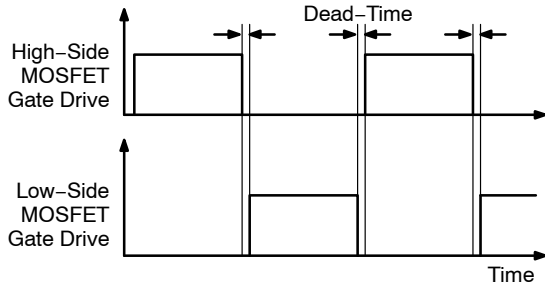

Figure 15. MOSFETs Gate Drive Signal

Internal Oscillator

FSFR-XS series employs a current-controlled oscillator, as shown in Figure 16. Internally, the voltage of R_T pin is regulated at 2 V and the charging / discharging current for the oscillator capacitor, C_T , is obtained by copying the current flowing out of the R_T pin (I_{CTC}) using a current mirror. Therefore, the switching frequency increases as I_{CTC} increases.

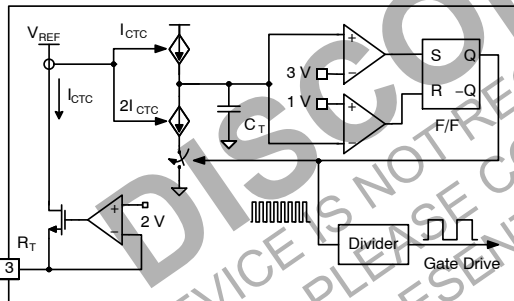

Figure 16. Current-Controlled Oscillator

Frequency Setting

Figure 17 shows the typical voltage gain curve of a resonant converter, where the gain is inversely proportional to the switching frequency in the ZVS region. The output voltage can be regulated by modulating the switching frequency. Figure 18 shows the typical circuit configuration for the R_T pin, where the opto-coupler transistor is connected to the R_T pin to modulate the switching frequency.

The minimum switching frequency is determined as:

$$f_{min} = \frac{5.2 \text{ k}\Omega}{R_{min}} \times 100 \text{ (kHz)} \quad (\text{eq. 1})$$

Assuming the saturation voltage of opto-coupler transistor is 0.2 V, the maximum switching frequency is determined as:

$$f_{max} = \left(\frac{5.2 \text{ k}\Omega}{R_{min}} + \frac{4.68 \text{ k}\Omega}{R_{max}} \right) \times 100 \text{ (kHz)} \quad (\text{eq. 2})$$

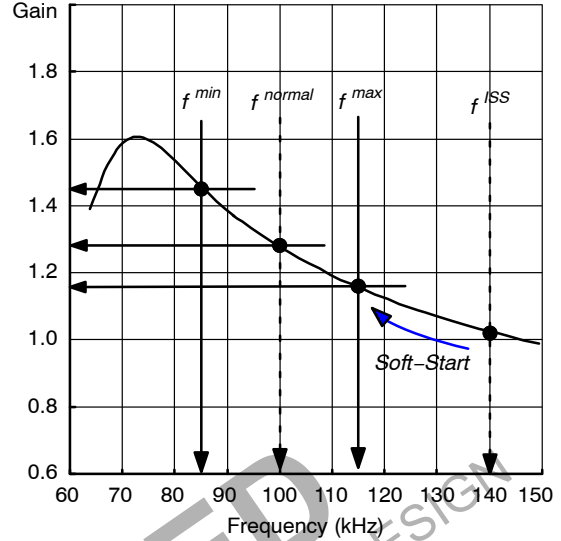

Figure 17. Resonant Converter Typical Gain Curve

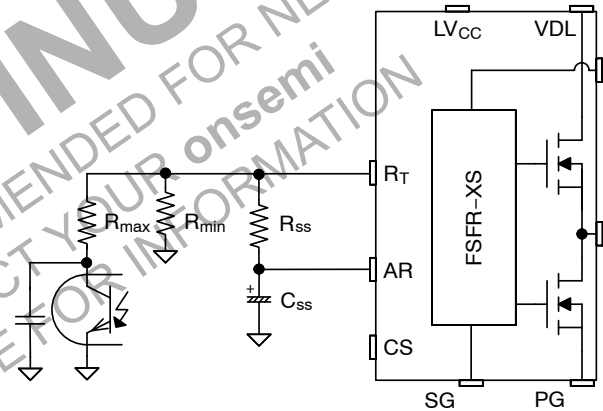

Figure 18. Frequency Control Circuit

To prevent excessive inrush current and overshoot of output voltage during startup, increase the voltage gain of the resonant converter progressively. Since the voltage gain of the resonant converter is inversely proportional to the switching frequency, the soft-start is implemented by sweeping down the switching frequency from an initial high frequency (f^{ISS}) until the output voltage is established. The soft-start circuit is made by connecting R-C series network on the R_T pin, as shown in Figure 18. FSFR-XS series also has a 3 ms internal soft-start to reduce the current overshoot during the initial cycles, which adds 40 kHz to the initial frequency of the external soft-start circuit, as shown in Figure 19. The initial frequency of the soft-start is given as:

$$f^{ISS} = \left(\frac{5.2 \text{ k}\Omega}{R_{min}} + \frac{5.2 \text{ k}\Omega}{R_{SS}} \right) \times 100 + 40 \text{ (kHz)} \quad (\text{eq. 3})$$

FSFR–XS Series

It is typical to set the initial frequency of soft-start two to three times the resonant frequency (f_0) of the resonant network. The soft-start time is three to four times the RC time constant. The RC time constant is:

$$\tau = R_{SS} \cdot C_{SS} \quad (\text{eq. 4})$$

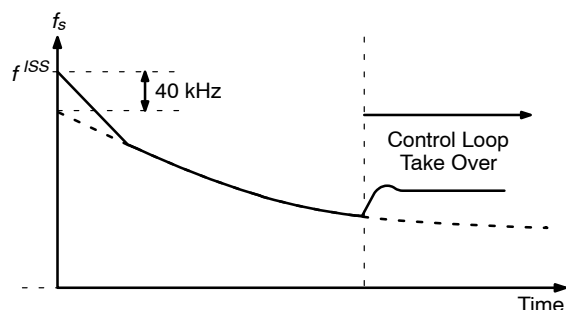

Figure 19. Frequency Sweeping of Soft-Start

Self Auto-Restart

The FSFR–XS series can restart automatically even though any built-in protections are triggered with external supply voltage. As can be seen in Figure 20 and Figure 21, once any protections are triggered, the M1 switch turns on and the V–I converter is disabled. C_{SS} starts to discharge until $V_{C_{SS}}$ across C_{SS} drops to $V_{C_{SSL}}$. Then, all protections are reset, M1 turns off, and the V–I converter resumes at the same time. The FSFR–XS starts switching again with soft-start. If the protections occur while $V_{C_{SS}}$ is under $V_{C_{SSL}}$ and $V_{C_{SSH}}$ level, the switching is terminated immediately. $V_{C_{SS}}$ continues to increase until reaching $V_{C_{SSH}}$, then C_{SS} is discharged by M1.

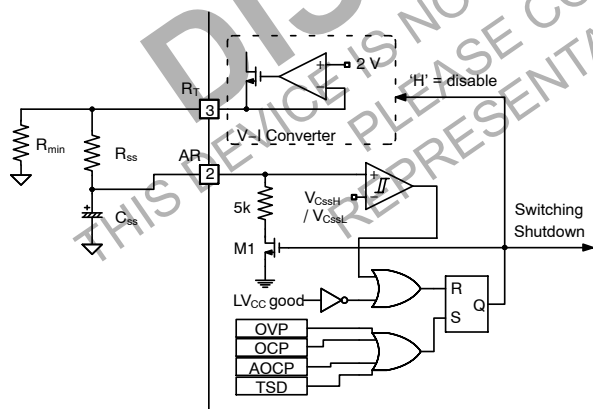

Figure 20. Internal Block of AR Pin

After protections trigger, FSFR–XS is disabled during the stop-time, t_{stop} , where $V_{C_{SS}}$ decreases and reaches to $V_{C_{SSL}}$. The stop-time of FSFR–XS can be estimated as:

$$t_{STOP} = C_{SS} \cdot \{(R_{SS} + R_{MIN}) \parallel 5 \text{ k}\Omega\} \quad (\text{eq. 5})$$

The soft-start time, $t_{s/s}$ can be set as Equation (4).

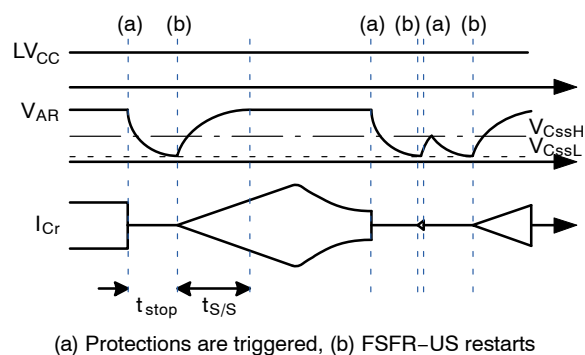

Figure 21. Self Auto-Restart Operation

Protection Circuits

The FSFR–XS series has several self-protective functions, such as Over-Current Protection (OCP), Abnormal Over-Current Protection (AOCP), Over-Voltage Protection (OVP), and Thermal Shutdown (TSD). These protections are auto-restart mode protections, as shown in Figure 22.

Once a fault condition is detected, switching is terminated and the MOSFETs remain off. When LV_{CC} falls to the LV_{CC} stop voltage of 10 V or AR signal is HIGH, the protection is reset. The FSFR–XS resumes normal operation when LV_{CC} reaches the start voltage of 12.5 V.

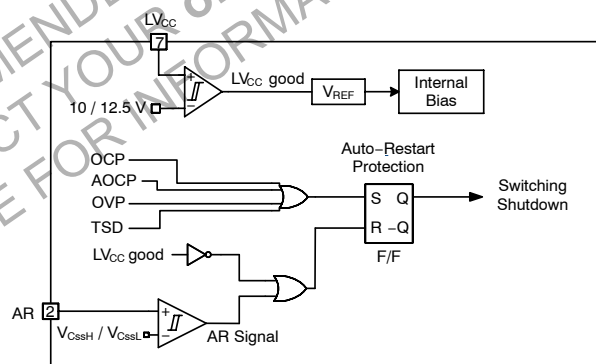

Figure 22. Protection Blocks

Over-Current Protection (OCP)

When the sensing pin voltage drops below -0.58 V , OCP is triggered and the MOSFETs remain off. This protection has a shutdown time delay of $1.5 \mu\text{s}$ to prevent premature shutdown during startup.

Abnormal Over-Current Protection (AOCP)

If the secondary rectifier diodes are shorted, large current with extremely high di/dt can flow through the MOSFET before OCP is triggered. AOCP is triggered without shutdown delay if the sensing pin voltage drops below -0.9 V .

Over-Voltage Protection (OVP)

When the LV_{CC} reaches 23 V , OVP is triggered. This protection is used when auxiliary winding of the transformer to supply V_{CC} to the power switch is utilized.

FSFR-XS Series

Thermal Shutdown (TSD)

The MOSFETs and the control IC in one package makes it easier for the control IC to detect the abnormal over-temperature of the MOSFETs. If the temperature exceeds approximately 130°C, thermal shutdown triggers.

Current Sensing Using a Resistor

FSFR-XS series senses drain current as a negative voltage, as shown in Figure 23 and Figure 24. Half-wave sensing allows low power dissipation in the sensing resistor, while full-wave sensing has less switching noise in the sensing signal.

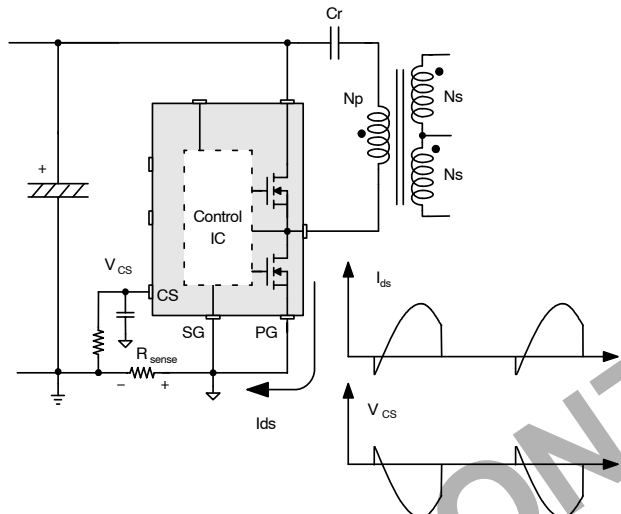

Figure 23. Half-Wave Sensing

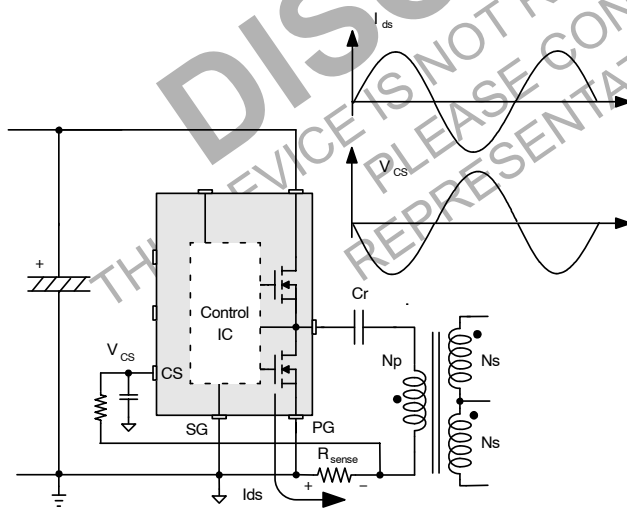

Figure 24. Full-Wave Sensing

PCB Layout Guidelines

Duty imbalance problems may occur due to the radiated noise from the main transformer, the inequality of the secondary side leakage inductances of main transformer, and so on. This is one of the reasons that the control components in the vicinity of R_T pin are enclosed by the primary current flow pattern on PCB layout. The direction of the magnetic field on the components caused by the primary current flow is changed when the high- and low-side MOSFET turn on by turns. The magnetic fields with opposite directions induce a current through, into, or out of the R_T pin, which makes the turn-on duration of each MOSFET different. It is strongly recommended to separate the control components in the vicinity of R_T pin from the primary current flow pattern on PCB layout. Figure 25 shows an example for the duty-balanced case.

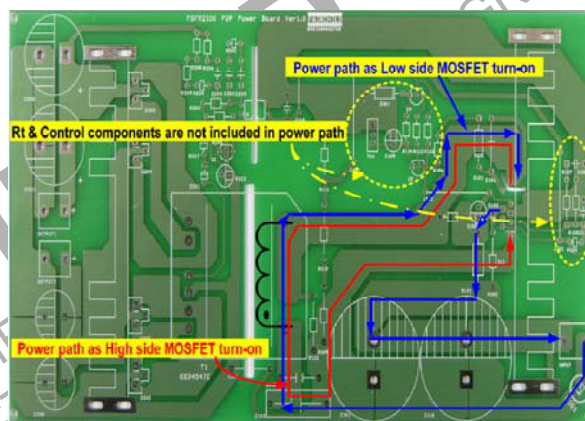

Figure 25. Example for Duty Balancing

MECHANICAL CASE OUTLINE

PACKAGE DIMENSIONS

ON Semiconductor®



SIP9 26x10.5
CASE 127EM
ISSUE O

DATE 31 DEC 2016

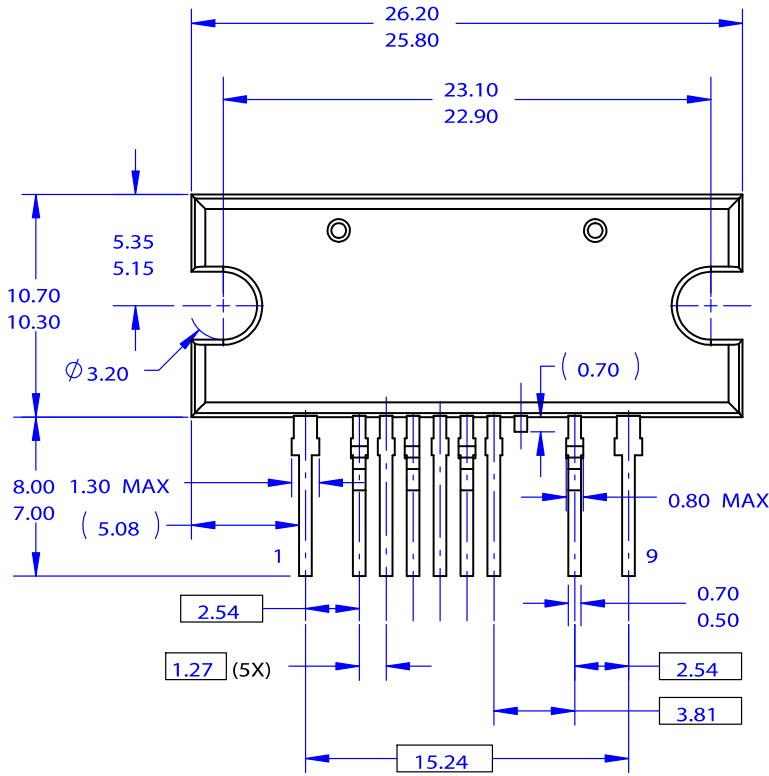

FRONT VIEW

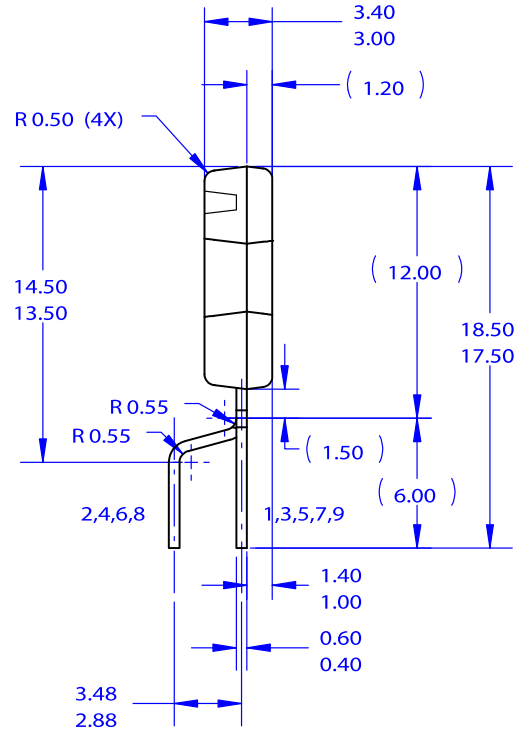

RIGHT SIDE VIEW

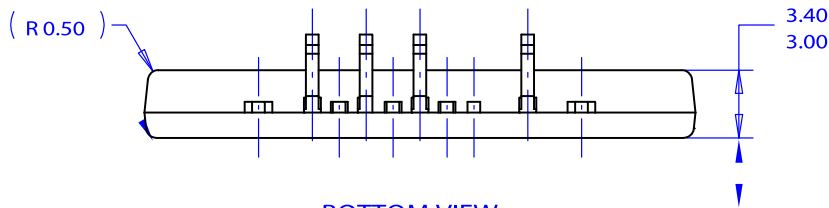

BOTTOM VIEW

NOTES: UNLESS OTHERWISE SPECIFIED

- A. THIS PACKAGE DOES NOT COMPLY TO ANY CURRENT PACKAGING STANDARD.
- B. ALL DIMENSIONS ARE IN MILLIMETERS.
- C. DIMENSIONS ARE EXCLUSIVE OF BURRS, MOLD FLASH AND TIE BAR PROTRUSIONS.

DOCUMENT NUMBER:	98AON13718G	Electronic versions are uncontrolled except when accessed directly from the Document Repository. Printed versions are uncontrolled except when stamped "CONTROLLED COPY" in red.
DESCRIPTION:	SIP9 26x10.5	PAGE 1 OF 1

ON Semiconductor and are trademarks of Semiconductor Components Industries, LLC dba ON Semiconductor or its subsidiaries in the United States and/or other countries. ON Semiconductor reserves the right to make changes without further notice to any products herein. ON Semiconductor makes no warranty, representation or guarantee regarding the suitability of its products for any particular purpose, nor does ON Semiconductor assume any liability arising out of the application or use of any product or circuit, and specifically disclaims any and all liability, including without limitation special, consequential or incidental damages. ON Semiconductor does not convey any license under its patent rights nor the rights of others.

MECHANICAL CASE OUTLINE
PACKAGE DIMENSIONS

ON Semiconductor®



SIP9 26x10.5
CASE 127EN
ISSUE O

DATE 31 DEC 2016

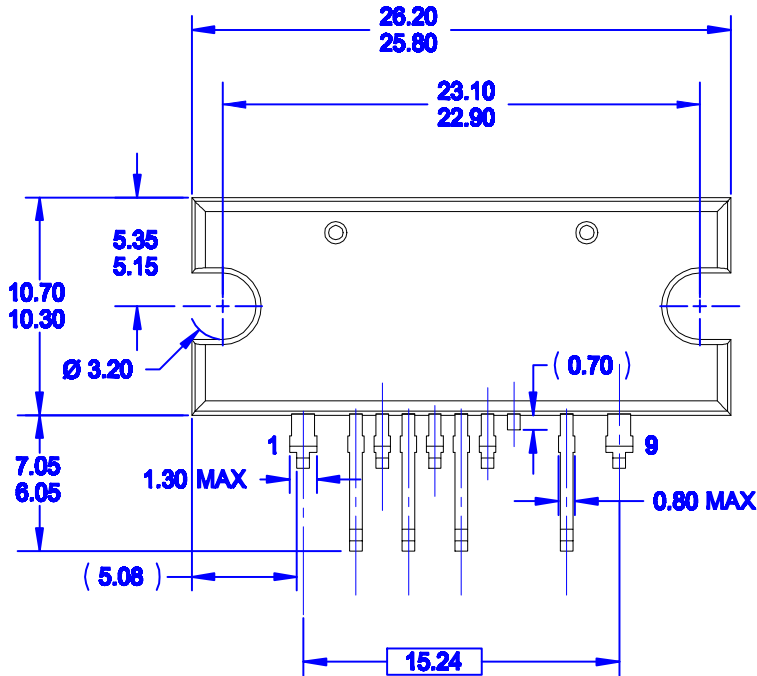

BOTTOM VIEW

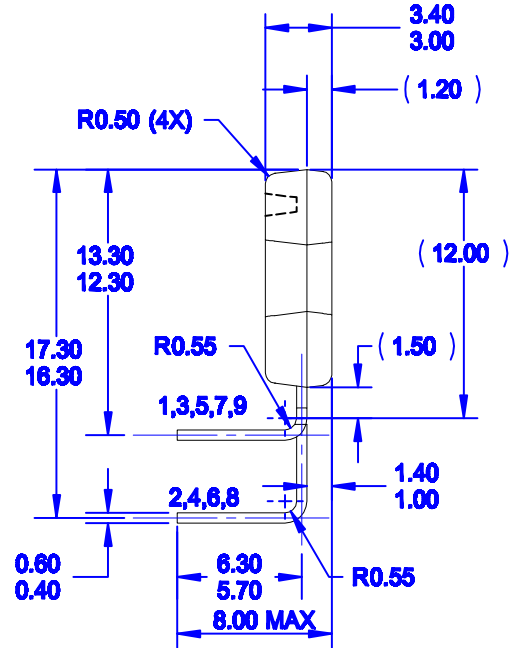

RIGHT SIDE VIEW

Note: Terminal face upwards

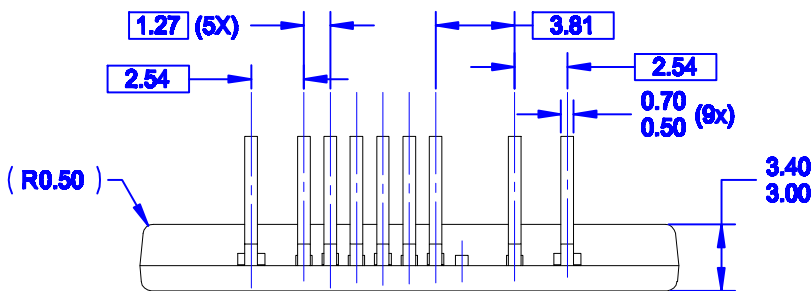

BACK VIEW

NOTES: UNLESS OTHERWISE SPECIFIED

- A. THIS PACKAGE DOES NOT COMPLY TO ANY CURRENT PACKAGING STANDARD.**
- B. ALL DIMENSIONS ARE IN MILLIMETERS.**
- C. DIMENSIONS ARE EXCLUSIVE OF BURRS, MOLD FLASH AND TIE BAR PROTRUSIONS.**

DOCUMENT NUMBER:	98AON13719G	Electronic versions are uncontrolled except when accessed directly from the Document Repository. Printed versions are uncontrolled except when stamped "CONTROLLED COPY" in red.
DESCRIPTION:	SIP9 26x10.5	PAGE 1 OF 1

ON Semiconductor and are trademarks of Semiconductor Components Industries, LLC dba ON Semiconductor or its subsidiaries in the United States and/or other countries. ON Semiconductor reserves the right to make changes without further notice to any products herein. ON Semiconductor makes no warranty, representation or guarantee regarding the suitability of its products for any particular purpose, nor does ON Semiconductor assume any liability arising out of the application or use of any product or circuit, and specifically disclaims any and all liability, including without limitation special, consequential or incidental damages. ON Semiconductor does not convey any license under its patent rights nor the rights of others.

onsemi, **Onsemi**, and other names, marks, and brands are registered and/or common law trademarks of Semiconductor Components Industries, LLC dba "**onsemi**" or its affiliates and/or subsidiaries in the United States and/or other countries. **onsemi** owns the rights to a number of patents, trademarks, copyrights, trade secrets, and other intellectual property. A listing of **onsemi**'s product/patent coverage may be accessed at www.onsemi.com/site/pdf/Patent-Marking.pdf. **onsemi** reserves the right to make changes at any time to any products or information herein, without notice. The information herein is provided "as-is" and **onsemi** makes no warranty, representation or guarantee regarding the accuracy of the information, product features, availability, functionality, or suitability of its products for any particular purpose, nor does **onsemi** assume any liability arising out of the application or use of any product or circuit, and specifically disclaims any and all liability, including without limitation special, consequential or incidental damages. Buyer is responsible for its products and applications using **onsemi** products, including compliance with all laws, regulations and safety requirements or standards, regardless of any support or applications information provided by **onsemi**. "Typical" parameters which may be provided in **onsemi** data sheets and/or specifications can and do vary in different applications and actual performance may vary over time. All operating parameters, including "Typicals" must be validated for each customer application by customer's technical experts. **onsemi** does not convey any license under any of its intellectual property rights nor the rights of others. **onsemi** products are not designed, intended, or authorized for use as a critical component in life support systems or any FDA Class 3 medical devices or medical devices with a same or similar classification in a foreign jurisdiction or any devices intended for implantation in the human body. Should Buyer purchase or use **onsemi** products for any such unintended or unauthorized application, Buyer shall indemnify and hold **onsemi** and its officers, employees, subsidiaries, affiliates, and distributors harmless against all claims, costs, damages, and expenses, and reasonable attorney fees arising out of, directly or indirectly, any claim of personal injury or death associated with such unintended or unauthorized use, even if such claim alleges that **onsemi** was negligent regarding the design or manufacture of the part. **onsemi** is an Equal Opportunity/Affirmative Action Employer. This literature is subject to all applicable copyright laws and is not for resale in any manner.

ADDITIONAL INFORMATION

TECHNICAL PUBLICATIONS:



Technical Library: www.onsemi.com/design/resources/technical-documentation
onsemi Website: www.onsemi.com

ONLINE SUPPORT: www.onsemi.com/support

For additional information, please contact your local Sales Representative at www.onsemi.com/support/sales

Looking for pricing, stock, or lifecycle information?

Click below to explore more details on WIN SOURCE:

-  [View FSFR2100XSL on WIN SOURCE](#)
-  [Fairchild/ON Semiconductor Information](#)

Optimize Your Supply Chain with WIN SOURCE Solutions

-  Global Sourcing Solution
-  Obsolete Management
-  Cost Control Management
-  Shortage Management
-  Alternative Solution
-  Excess Inventory Management