



# THE DATASHEET OF FSGM300N



# FSGM300N

## Green-Mode Power Switch

### Description

The FSGM300N is an integrated Pulse Width Modulation (PWM) controller and SENSEFET<sup>®</sup> specifically designed for offline Switch-Mode Power Supplies (SMPS) with minimal external components. The PWM controller includes an integrated fixed-frequency oscillator, Under-Voltage Lockout (UVLO), Leading-Edge Blanking (LEB), optimized gate driver, internal soft-start, temperature-compensated precise current sources for loop compensation, and self-protection circuitry. Compared with a discrete MOSFET and PWM controller solution, the FSGM series can reduce total cost, component count, size, and weight; while simultaneously increasing efficiency, productivity, and system reliability. This device provides a basic platform suited for cost-effective design of a flyback converter.

### Features

- Advanced Burst-Mode Operation for Low Standby Power
- Random Frequency Fluctuation for Low EMI
- Pulse-by-Pulse Current Limit
- Various Protection Functions: Overload Protection (OLP), Over-Voltage Protection (OVP), Abnormal Over-Current Protection (AOCP), Internal Thermal Shutdown (TSD) with Hysteresis, Output-Short Protection (OSP), and Under-Voltage Lockout (UVLO) with Hysteresis
- Auto-Restart Mode
- Internal Startup Circuit
- Internal High-Voltage SENSEFET: 650 V
- Built-in Soft-Start: 15 ms
- This is a Pb-Free Device

### Applications

- Power Supply for LCD Monitor, STB and DVD Combination



**ON Semiconductor<sup>®</sup>**

[www.onsemi.com](http://www.onsemi.com)

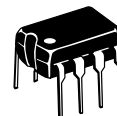

**PDIP-8  
CASE 626-05**

### MARKING DIAGRAM

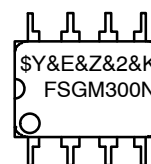

\$Y	= ON Semiconductor Logo
&E	'= Designates Space
&Z	= Assembly Plant Code
&2	= 2-Digit Date Code Format
&K	= 2-Digit Lot Run Traceability Code
FSGM300N	= Specific Device Code

### ORDERING INFORMATION

See detailed ordering and shipping information on page 2 of this data sheet.

# FSGM300N

## ORDERING INFORMATION

Part Number	Package	Operating Junction Temperature	Current Limit	$R_{DS(ON)}$ (Max.)	Output Power Table (Note 2)				Replaces Device	Shipping
					230V <sub>AC</sub> ± 15% (Note 3)		85 – 265 V <sub>AC</sub>			
					Adapter (Note 4)	Open Frame (Note 5)	Adapter (Note 4)	Open Frame (Note 5)		
FSGM300N	8-DIP	-40°C ~ +125°C	1.60 A	2.2 Ω	26 W	40 W	20 W	30 W	FSFM300N	3000 / Tube

1. Pb-free package per JEDEC J-STD-020B.
2. The junction temperature can limit the maximum output power.
3. 230 V<sub>AC</sub> or 100 / 115 V<sub>AC</sub> with voltage doubler.
4. Typical continuous power in a non-ventilated enclosed adapter measured at 50°C ambient temperature.
5. Maximum practical continuous power in an open-frame design at 50°C ambient temperature.

## Application Circuit

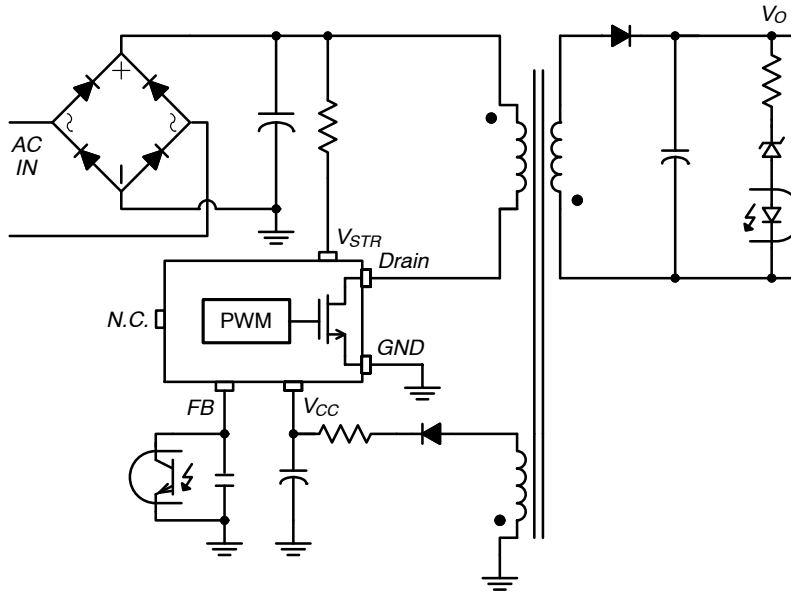

Figure 1. Typical Application Circuit



# FSGM300N

## PIN DEFINITIONS

Pin No.	Name	Description
1	GND	<i>Ground.</i> This pin is the control ground and the SENSEFET source.
2	V <sub>CC</sub>	<i>Power Supply.</i> This pin is the positive supply input, which provides the internal operating current for both startup and steady-state operation.
3	FB	<i>Feedback.</i> This pin is internally connected to the inverting input of the PWM comparator. The collector of an opto-coupler is typically tied to this pin. For stable operation, a capacitor should be placed between this pin and GND. If the voltage of this pin reaches 6 V, the overload protection triggers, which shuts down the power switch.
4	N.C.	No connection.
5	V <sub>STR</sub>	<i>Startup.</i> This pin is connected directly, or through a resistor, to the high-voltage DC link. At startup, the internal high-voltage current source supplies internal bias and charges the external capacitor connected to the V <sub>CC</sub> pin. Once V <sub>CC</sub> reaches 12 V, the internal current source (I <sub>CH</sub> ) is disabled.
6, 7, 8	Drain	<i>SENSEFET Drain.</i> High-voltage power SENSEFET drain connection.

## ABSOLUTE MAXIMUM RATINGS

Symbol	Parameter	Min	Max	Unit	
V <sub>STR</sub>	V <sub>STR</sub> Pin Voltage	–	650	V	
V <sub>DS</sub>	Drain Pin Voltage	–	650	V	
V <sub>CC</sub>	V <sub>CC</sub> Pin Voltage	–	26	V	
V <sub>FB</sub>	Feedback Pin Voltage	–0.3	8.0	V	
I <sub>DM</sub>	Drain Current Pulsed	–	4	A	
I <sub>DS</sub>	Continuous Switching Drain Current (Note 6)	T <sub>C</sub> = 25°C	–	1.90	A
		T <sub>C</sub> = 100°C	–	1.27	A
E <sub>AS</sub>	Single Pulsed Avalanche Energy (Note 7)	–	190	mJ	
P <sub>D</sub>	Total Power Dissipation (T <sub>C</sub> = 25°C) (Note 8)	–	1.5	W	
T <sub>J</sub>	Maximum Junction Temperature	–	150	°C	
	Operating Junction Temperature (Note 9)	–40	+125	°C	
T <sub>STG</sub>	Storage Temperature	–55	+150	°C	
ESD	Electrostatic Discharge Capability	Human Body Model, JESD22-A114	2	–	kV
		Charged Device Model, JESD22-C101	2	–	

Stresses exceeding those listed in the Maximum Ratings table may damage the device. If any of these limits are exceeded, device functionality should not be assumed, damage may occur and reliability may be affected.

6. Repetitive peak switching current when the inductive load is assumed: Limited by maximum duty (D<sub>MAX</sub> = 0.83) and junction temperature (see Figure 4).
7. L = 45 mH, starting T<sub>J</sub> = 25°C.
8. Infinite cooling condition (refer to the SEMI G30–88).
9. Although this parameter guarantees IC operation, it does not guarantee all electrical characteristics.

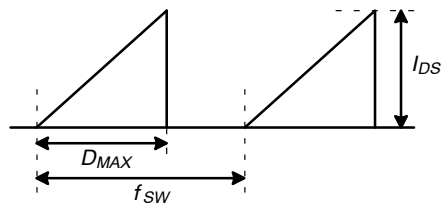

Figure 4. Repetitive Peak Switching Current

# FSGM300N

## THERMAL CHARACTERISTICS

Symbol	Characteristic	Value	Unit
$\theta_{JA}$	Junction-to-Ambient Thermal Impedance (Note 10)	80	°C/W
$\theta_{JC}$	Junction-to-Case Thermal Impedance (Note 11)	20	°C/W
$\Psi_{JT}$	Junction-to-Top Thermal Impedance (Note 12)	35	°C/W

10. Infinite cooling condition (refer to the SEMI G30-88).

11. Free standing with no heat-sink under natural convection.

12. Measured on the package top surface.

## ELECTRICAL CHARACTERISTICS ( $T_J = 25^\circ\text{C}$ unless otherwise noted)

Symbol	Parameter	Test Condition	Min	Typ	Max	Unit
--------	-----------	----------------	-----	-----	-----	------

### SENSEFET SECTION

$BV_{DSS}$	Drain-Source Breakdown Voltage	$V_{CC} = 0\text{ V}, I_D = 250\ \mu\text{A}$	650	-	-	V
$I_{DSS}$	Zero-Gate-Voltage Drain Current	$V_{DS} = 520\text{ V}, T_A = 125^\circ\text{C}$	-	-	250	$\mu\text{A}$
$R_{DS(ON)}$	Drain-Source On-State Resistance	$V_{GS} = 10\text{ V}, I_D = 1\text{ A}$	-	1.8	2.2	$\Omega$
$C_{ISS}$	Input Capacitance (Note 13)	$V_{DS} = 25\text{ V}, V_{GS} = 0\text{ V}, f = 1\text{ MHz}$	-	515	-	pF
$C_{OSS}$	Output Capacitance (Note 13)	$V_{DS} = 25\text{ V}, V_{GS} = 0\text{ V}, f = 1\text{ MHz}$	-	75	-	pF
$t_r$	Rise Time	$V_{DS} = 325\text{ V}, I_D = 4\text{ A}, R_G = 25\ \Omega$	-	26	-	ns
$t_f$	Fall Time	$V_{DS} = 325\text{ V}, I_D = 4\text{ A}, R_G = 25\ \Omega$	-	25	-	ns
$t_{d(on)}$	Turn-On Delay Time	$V_{DS} = 325\text{ V}, I_D = 4\text{ A}, R_G = 25\ \Omega$	-	14	-	ns
$t_{d(off)}$	Turn-Off Delay Time	$V_{DS} = 325\text{ V}, I_D = 4\text{ A}, R_G = 25\ \Omega$	-	32	-	ns

### CONTROL SECTION

$f_S$	Switching Frequency (Note 13)	$V_{CC} = 14\text{ V}, V_{FB} = 4\text{ V}$	61	67	73	kHz
$\Delta f_S$	Switching Frequency Variation (Note 13)	$-25^\circ\text{C} < T_J < 125^\circ\text{C}$	-	$\pm 5$	$\pm 10$	%
$D_{MAX}$	Maximum Duty Ratio	$V_{CC} = 14\text{ V}, V_{FB} = 4\text{ V}$	71	77	83	%
$D_{MIN}$	Minimum Duty Ratio	$V_{CC} = 14\text{ V}, V_{FB} = 0\text{ V}$	-	-	0	%
$I_{FB}$	Feedback Source Current	$V_{FB} = 0$	120	150	180	$\mu\text{A}$
$V_{START}$	UVLO Threshold Voltage	$V_{FB} = 0\text{ V}, V_{CC}$ Sweep	11	12	13	V
$V_{STOP}$		After Turn-on, $V_{FB} = 0\text{ V}$	7.0	7.7	8.5	V
$V_{OP}$	$V_{CC}$ Operating Range		13	-	22.5	V
$t_{S/S}$	Internal Soft-Start Time	$V_{STR} = 40\text{ V}, V_{CC}$ Sweep	-	15	-	ms

### BURST-MODE SECTION

$V_{BURH}$	Burst-Mode Voltage	$V_{CC} = 14\text{ V}, V_{FB}$ Sweep	0.6	0.7	0.8	V
$V_{BURL}$			0.4	0.5	0.6	V
Hys			-	200	-	mV

# FSGM300N

## ELECTRICAL CHARACTERISTICS (T<sub>J</sub> = 25°C unless otherwise noted) (continued)

Symbol	Parameter	Test Condition	Min	Typ	Max	Unit	
<b>PROTECTION SECTION</b>							
I <sub>LIM</sub>	Peak Drain Current Limit	di/dt = 300 mA/μs	1.44	1.60	1.76	A	
V <sub>SD</sub>	Shutdown Feedback Voltage	V <sub>CC</sub> = 14 V, V <sub>FB</sub> Sweep	5.5	6.0	6.5	V	
I <sub>DELAY</sub>	Shutdown Delay Current	V <sub>CC</sub> = 14 V, V <sub>FB</sub> = 4 V	2.0	2.7	3.4	μA	
t <sub>LEB</sub>	Leading-Edge Blanking Time (Note 13, 15)		–	400	–	ns	
V <sub>OVP</sub>	Over-Voltage Protection	V <sub>CC</sub> Sweep	22.5	24.0	25.5	V	
t <sub>OSP</sub>	Output Short Protection (Note 13)	Threshold Time	OSP Triggered when t <sub>ON</sub> < t <sub>OSP</sub> & V <sub>FB</sub> > V <sub>OSP</sub> (Lasts Longer than t <sub>OSP_FB</sub> )	0.7	1.0	1.3	μs
V <sub>OSP</sub>		Threshold V <sub>FB</sub>		1.4	1.6	1.8	V
t <sub>OSP_FB</sub>		V <sub>FB</sub> Blanking Time		2.0	2.5	3.0	μs
T <sub>SD</sub>	Thermal Shutdown Temperature (Note 13)	Shutdown Temperature	125	135	145	°C	
Hys		Hysteresis	–	40	–	°C	

## TOTAL DEVICE SECTION

I <sub>OP</sub>	Operating Supply Current, (Control Part in Burst Mode)	V <sub>CC</sub> = 14 V, V <sub>FB</sub> = 0 V	1.0	1.5	2.0	mA
I <sub>OPS</sub>	Operating Switching Current, (Control Part and SENSEFET Part)	V <sub>CC</sub> = 14 V, V <sub>FB</sub> = 2 V	2.1	2.5	2.9	mA
I <sub>START</sub>	Start Current	V <sub>CC</sub> = 11 V (Before V <sub>CC</sub> Reaches V <sub>START</sub> )	400	500	600	μA
I <sub>CH</sub>	Startup Charging Current	V <sub>CC</sub> = V <sub>FB</sub> = 0 V, V <sub>STR</sub> = 40 V	0.95	1.10	1.50	mA
V <sub>STR</sub>	Minimum V <sub>STR</sub> Supply Voltage	V <sub>CC</sub> = V <sub>FB</sub> = 0 V, V <sub>STR</sub> Sweep	–	26	–	V

Product parametric performance is indicated in the Electrical Characteristics for the listed test conditions, unless otherwise noted. Product performance may not be indicated by the Electrical Characteristics if operated under different conditions.

13. Although these parameters are guaranteed, they are not 100% tested in production.

14. Average value.

15. t<sub>LEB</sub> includes gate turn-on time.

**Table 1. COMPARISON OF FSFM300N AND FSGM300N**

Function	FSFM300N	FSGM300N	Advantages of FSFM300N
Random Frequency Fluctuation		Built-in	Low EMI
Operating Current	3 mA	1.4 mA	Very low stand-by power
Protections	OLP OVP AOCP TSD	OLP OVP OSP AOCP TSD with Hysteresis	Enhanced protections and high reliability
Power Balance	Long T <sub>CLD</sub>	Very Short T <sub>CLD</sub>	The difference of input power between the low and high input voltage is quite small

# FSGM300N

## TYPICAL CHARACTERISTICS ( $T_A = 25^\circ\text{C}$ unless otherwise noted)

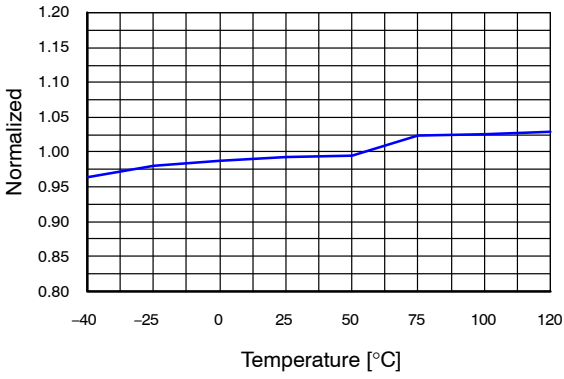

Figure 5. Operating Supply Current ( $I_{OP}$ ) vs.  $T_A$

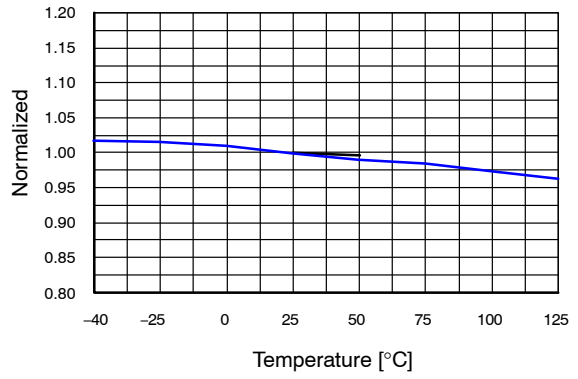

Figure 6. Operating Switching Current ( $I_{OPS}$ ) vs.  $T_A$

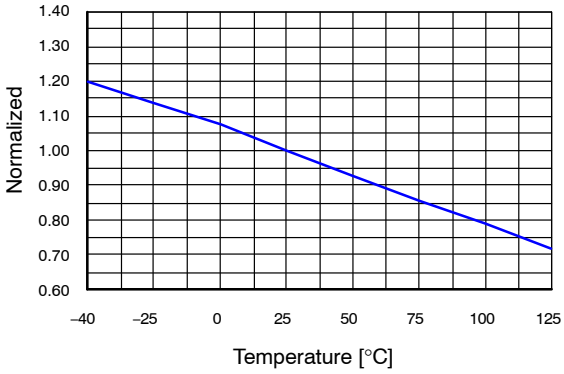

Figure 7. Startup Charging Current ( $I_{CH}$ ) vs.  $T_A$

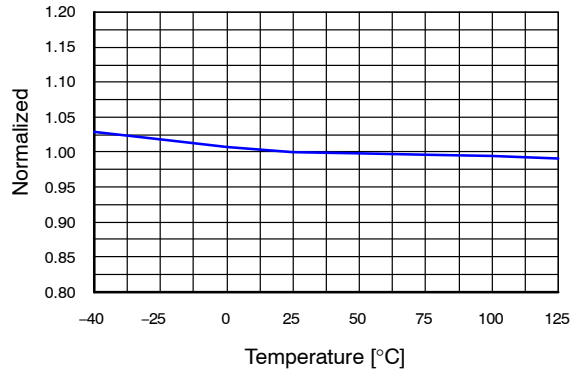

Figure 8. Peak Drain Current Limit ( $I_{LIM}$ ) vs.  $T_A$

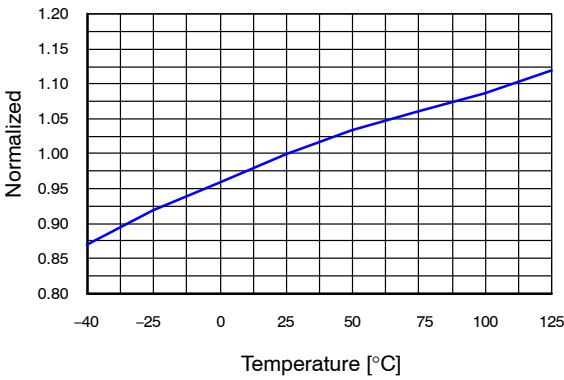

Figure 9. Feedback Source Current ( $I_{FB}$ ) vs.  $T_A$

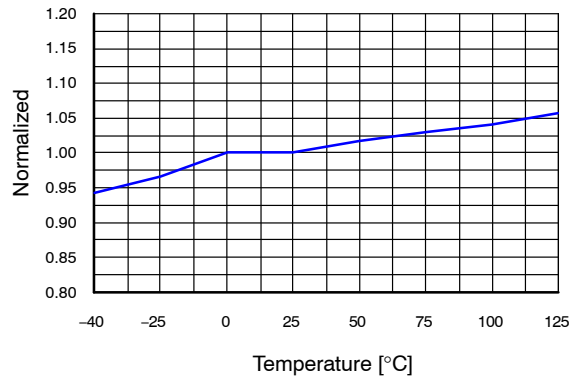

Figure 10. Shutdown Delay Current ( $I_{DELAY}$ ) vs.  $T_A$

# FSGM300N

## TYPICAL CHARACTERISTICS ( $T_A = 25^\circ\text{C}$ unless otherwise noted)

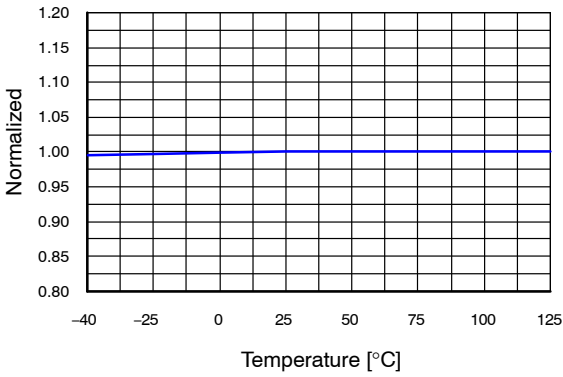

Figure 11. UVLO Threshold Voltage ( $V_{START}$ ) vs.  $T_A$

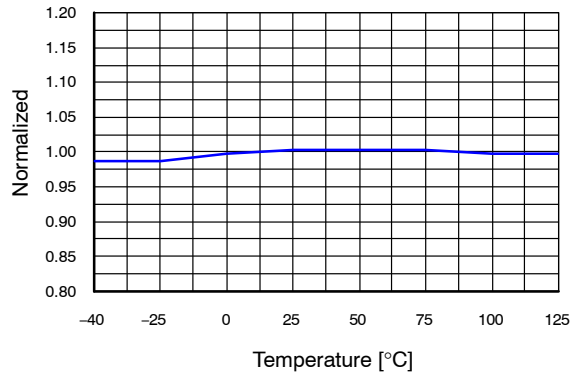

Figure 12. UVLO Threshold Voltage ( $V_{STOP}$ ) vs.  $T_A$

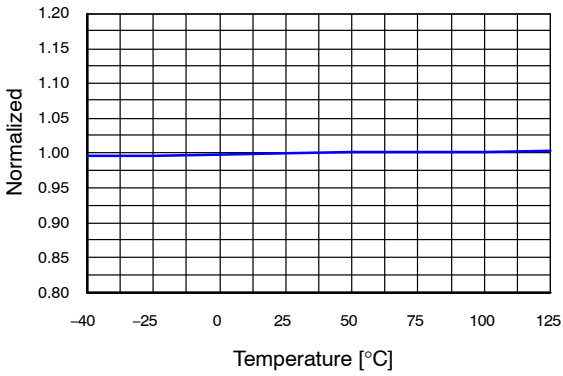

Figure 13. Shutdown Feedback Voltage ( $V_{SD}$ ) vs.  $T_A$

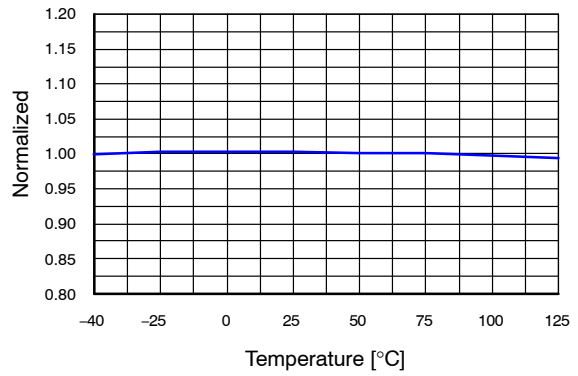

Figure 14. Over-Voltage Protection ( $V_{OVP}$ ) vs.  $T_A$

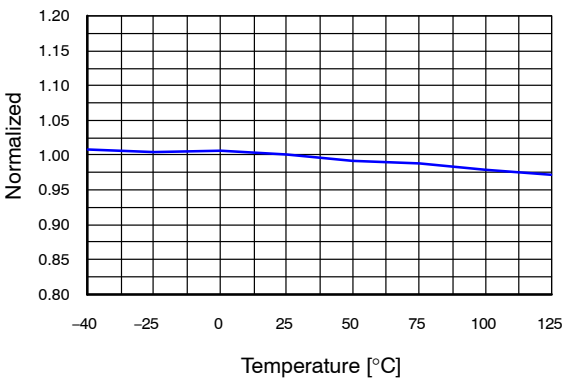

Figure 15. Switching Frequency ( $f_S$ ) vs.  $T_A$

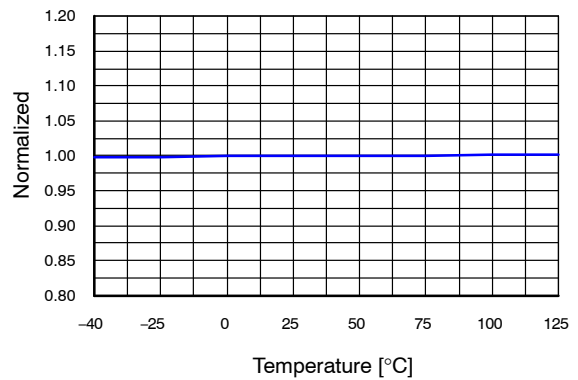
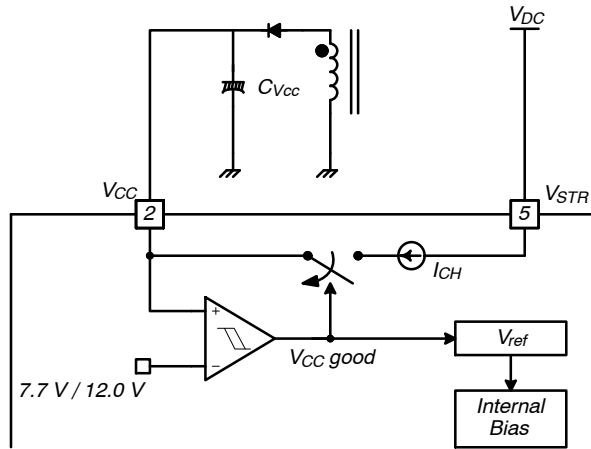

Figure 16. Maximum Duty Ratio ( $D_{MAX}$ ) vs.  $T_A$

**FUNCTIONAL DESCRIPTION**

**Startup**

At startup, an internal high-voltage current source supplies the internal bias and charges the external capacitor ( $C_{VCC}$ ) connected to the  $V_{CC}$  pin, as illustrated in Figure 17. When  $V_{CC}$  reaches 12 V, the FSGM300N begins switching and the internal high-voltage current source is disabled. The FSGM300N continues normal switching operation and the power is supplied from the auxiliary transformer winding unless  $V_{CC}$  goes below the stop voltage of 7.7 V.



**Figure 17. Startup Block**

**Soft-Start**

The FSGM300N has an internal soft-start circuit that increases PWM comparator inverting input voltage, together with the SENSEFET current, slowly after it starts. The typical soft-start time is 15 ms. The pulse width to the power switching device is progressively increased to establish the correct working conditions for transformers, inductors, and capacitors. The voltage on the output capacitors is progressively increased to smoothly establish

the required output voltage. This helps prevent transformer saturation and reduces stress on the secondary diode during startup.

**Feedback Control**

This device employs current-mode control, as shown in Figure 18. An opto-coupler (such as the FOD817) and shunt regulator (such as the KA431) are typically used to implement the feedback network. Comparing the feedback voltage with the voltage across the  $R_{SENSE}$  resistor makes it possible to control the switching duty cycle. When the reference pin voltage of the shunt regulator exceeds the internal reference voltage of 2.5 V, the opto-coupler LED current increases, pulling down the feedback voltage and reducing drain current. This typically occurs when the input voltage is increased or the output load is decreased.

*Pulse-by-Pulse Current Limit*

Because current-mode control is employed, the peak current through the SENSEFET is limited by the inverting input of PWM comparator ( $V_{FB}^*$ ), as shown in Figure 18. Assuming that the 150  $\mu$ A current source flows only through the internal resistor ( $3R + R = 16 \text{ k}\Omega$ ), the cathode voltage of diode D2 is about 2.4 V. Since D1 is blocked when the feedback voltage ( $V_{FB}$ ) exceeds 2.4 V, the maximum voltage of the cathode of D2 is clamped at this voltage. Therefore, the peak value of the current through the SENSEFET is limited.

*Leading-Edge Blanking (LEB)*

At the instant the internal SENSEFET is turned on, a high-current spike usually occurs through the SENSEFET, caused by primary-side capacitance and secondary-side rectifier reverse recovery. Excessive voltage across the  $R_{SENSE}$  resistor leads to incorrect feedback operation in the current mode PWM control. To counter this effect, the FSGM300N employs a leading-edge blanking (LEB) circuit. This circuit inhibits the PWM comparator for  $t_{LEB}$  (400 ns) after the SenseFET is turned on.

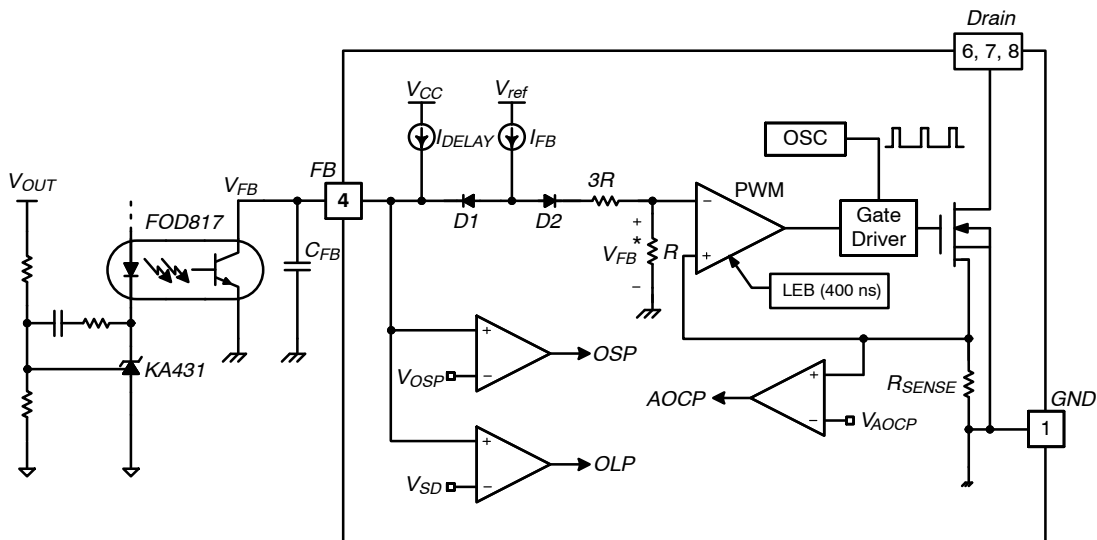

**Figure 18. Pulse Width Modulation Circuit**

**Protection Circuits**

The FSGM300N has several self-protective functions, such as Overload Protection (OLP), Abnormal Over-Current Protection (AOCP), Output-Short Protection (OSP), Over-Voltage Protection (OVP), and Thermal Shutdown (TSD). All the protections are implemented as auto-restart. Once the fault condition is detected, switching is terminated and the SENSEFET remains off. This causes  $V_{CC}$  to fall. When  $V_{CC}$  falls to the Under-Voltage Lockout (UVLO) stop voltage of 7.7 V, the protection is reset and the startup circuit charges the  $V_{CC}$  capacitor. When  $V_{CC}$  reaches the start voltage of 12.0 V, the FSGM300N resumes normal operation. If the fault condition is not removed, the SENSEFET remains off and  $V_{CC}$  drops to stop voltage again. In this manner, the auto-restart can alternately enable and disable the switching of the power SENSEFET until the fault condition is eliminated. Because these protection circuits are fully integrated into the IC without external components, the reliability is improved without increasing cost.

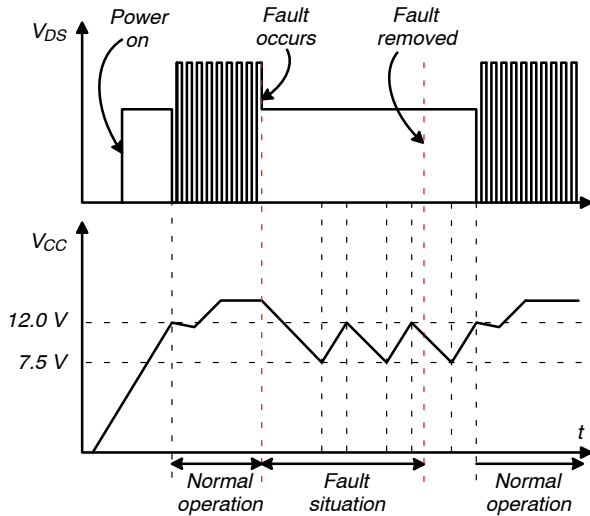
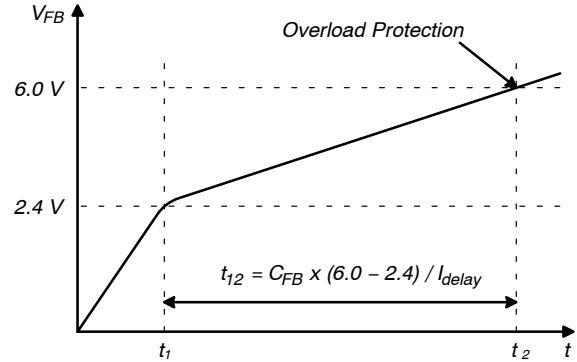

**Figure 19. Auto-Restart Protection Waveforms**

*Overload Protection (OLP)*

Overload is defined as the load current exceeding its normal level due to an unexpected abnormal event. In this situation, the protection circuit should trigger to protect the SMPS. However, even when the SMPS is in normal operation, the overload protection circuit can be triggered during the load transition. To avoid this undesired operation, the overload protection circuit is designed to trigger only after a specified time to determine whether it is a transient situation or a true overload situation. Because of the pulse-by-pulse current limit capability, the maximum peak current through the SENSEFET is limited and, therefore, the maximum input power is restricted with a given input voltage. If the output consumes more than this maximum power, the output voltage ( $V_{OUT}$ ) decreases below the set voltage. This reduces the current through the opto-coupler LED, which also reduces the opto-coupler transistor

current, thus increasing the feedback voltage ( $V_{FB}$ ). If  $V_{FB}$  exceeds 2.4 V, D1 is blocked and the 2.7  $\mu$ A current source starts to charge  $C_{FB}$  slowly up. In this condition,  $V_{FB}$  continues increasing until it reaches 6.0 V, when the switching operation is terminated, as shown in Figure 20. The delay time for shutdown is the time required to charge  $C_{FB}$  from 2.4 V to 6.0 V with 2.7  $\mu$ A. A 25 ~ 50 ms delay is typical for most applications. This protection is implemented in auto-restart mode.



**Figure 20. Overload Protection**

*Abnormal Over-Current Protection (AOCP)*

When the secondary rectifier diodes or the transformer pins are shorted, a steep current with extremely high di/dt can flow through the SENSEFET during the minimum turn-on time. Even though the FSGM300N has overload protection, it is not enough to protect the FSGM300N in that abnormal case; since severe current stress is imposed on the SENSEFET until OLP is triggered. The FSGM300N internal AOCP circuit is shown in Figure 21. When the gate turn-on signal is applied to the power SENSEFET, the AOCP block is enabled and monitors the current through the sensing resistor. The voltage across the resistor is compared with a preset AOCP level. If the sensing resistor voltage is greater than the AOCP level, the set signal is applied to the S-R latch, resulting in the shutdown of the SMPS.

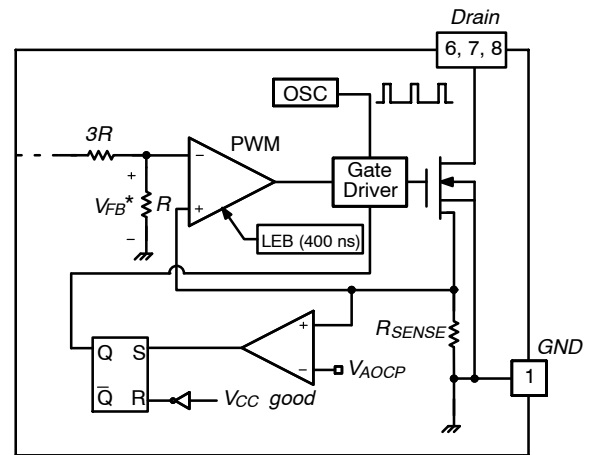

**Figure 21. Abnormal Over-Current Protection**

**Output-Short Protection (OSP)**

If the output is shorted, steep current with extremely high di/dt can flow through the SENSEFET during the minimum turn-on time. Such a steep current brings high-voltage stress on the drain of the SENSEFET when turned off. To protect the device from this abnormal condition, OSP is included. It is comprised of detecting  $V_{FB}$  and SENSEFET turn-on time. When the  $V_{FB}$  is higher than 1.6 V and the SENSEFET turn-on time is lower than 1.0  $\mu$ s, the FSGM300N recognizes this condition as an abnormal error and shuts down PWM switching until  $V_{CC}$  reaches  $V_{START}$  again. An abnormal condition output short is shown in Figure 22.

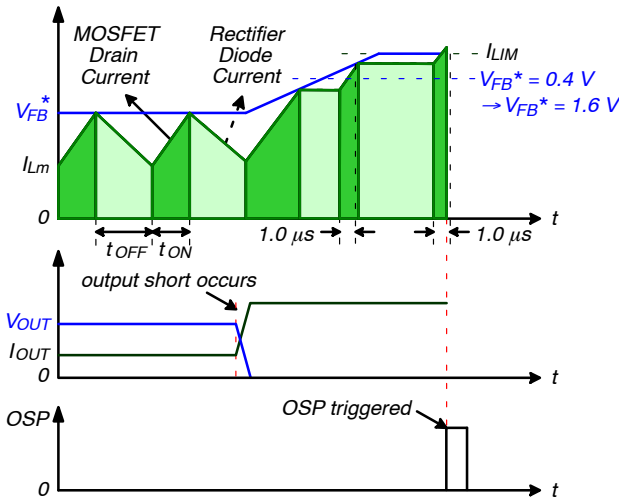

**Figure 22. Output-Short Protection**

**Over-Voltage Protection (OVP)**

If the secondary-side feedback circuit malfunctions or a solder defect causes an opening in the feedback path, the current through the opto-coupler transistor becomes almost zero. Then  $V_{FB}$  climbs up in a similar manner to the overload situation, forcing the preset maximum current to be supplied to the SMPS until the overload protection is triggered. Because more energy than required is provided to the output, the output voltage may exceed the rated voltage before the overload protection is triggered, resulting in the breakdown of the devices in the secondary side. To prevent this situation, an OVP circuit is employed. In general, the  $V_{CC}$  is proportional to the output voltage and the FSGM300N uses  $V_{CC}$  instead of directly monitoring the output voltage. If  $V_{CC}$  exceeds 24.0 V, an OVP circuit is triggered, resulting in the termination of the switching operation. To avoid undesired activation of OVP during normal operation,  $V_{CC}$  should be designed to be below 24.0 V.

**Thermal Shutdown (TSD)**

The SENSEFET and the control IC on a die in one package makes it easier for the control IC to detect the over temperature of the SENSEFET. If the temperature exceeds  $\sim 135^{\circ}\text{C}$ , the thermal shutdown is triggered and stops

operation. The FSGM300N operates in auto-restart mode until the temperature decreases to around  $95^{\circ}\text{C}$ , when normal operation resumes.

**Soft Burst-Mode Operation**

To minimize power dissipation in standby mode, the FSGM300N enters burst-mode operation. As the load decreases, the feedback voltage decreases. As shown in Figure 23, the device automatically enters burst mode when the feedback voltage drops below  $V_{BURL}$  (500 mV). At this point, switching stops and the output voltages start to drop at a rate dependent on standby current load. This causes the feedback voltage to rise. Once it passes  $V_{BURH}$  (700 mV), switching resumes. The feedback voltage then falls and the process repeats. Burst-mode operation alternately enables and disables switching of the SENSEFET, thereby reducing switching loss in standby mode.

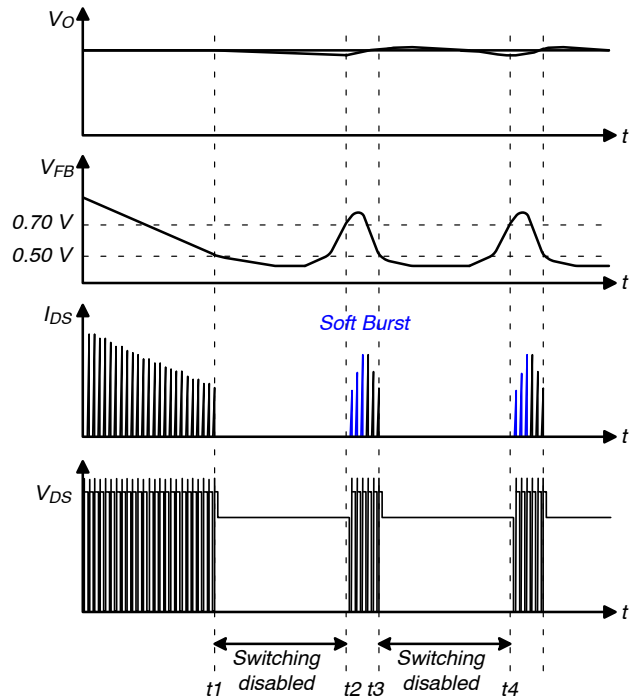

**Figure 23. Burst-Mode Operation**

**Random Frequency Fluctuation (RFF)**

Fluctuating switching frequency of an SMPS can reduce EMI by spreading the energy over a wide frequency range. The amount of EMI reduction is directly related to the switching frequency variation, which is limited internally. The switching frequency is determined randomly by external feedback voltage and internal free-running oscillator at every switching instant. This Random Frequency Fluctuation scatters the EMI noise around typical switching frequency (67 kHz) effectively and can reduce the cost of the input filter included to meet the EMI requirements (e.g. EN55022).

# FSGM300N

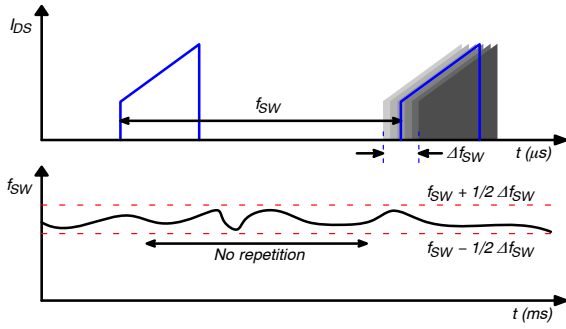

Figure 24. Random Frequency Fluctuation

## TYPICAL APPLICATION CIRCUIT

Table 2. TYPICAL APPLICATION CIRCUIT

Application	Input Voltage	Rated Output	Rated Power
LCD Monitor Power Supply	85 ~ 265 V <sub>AC</sub>	5.0 V (2 A) 14.0 V (1.2 A)	26.8 W

### Key Design Notes:

1. The delay time for overload protection is designed to be about 30 ms with C105 (22 nF). OLP time between 25 ms (18 nF) and 50 ms (39 nF) is recommended.
2. The SMD-type capacitor (C106) must be placed as close as possible to the V<sub>CC</sub> pin to avoid malfunction by abrupt pulsating noises and to improve ESD and surge immunity. Capacitance between 100 nF and 220 nF is recommended.

## Schematic

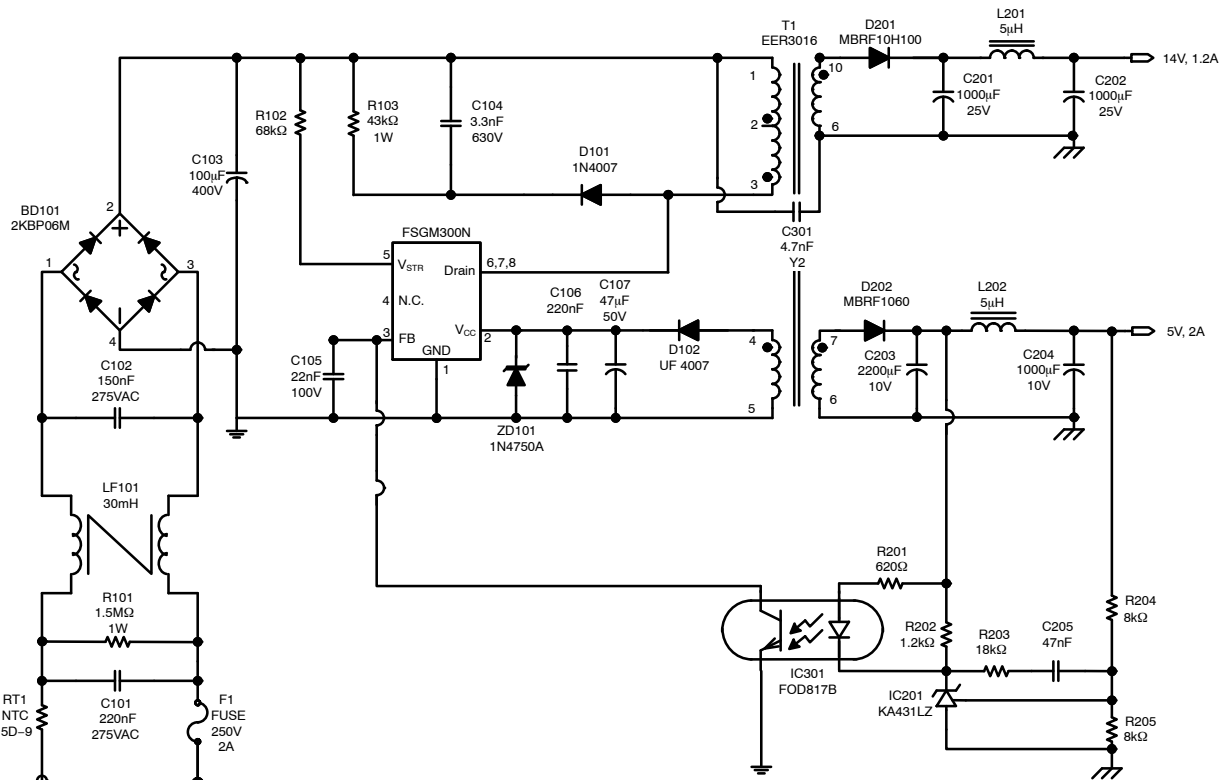

Figure 25. Schematic of Demonstration Board

# FSGM300N

## Transformer

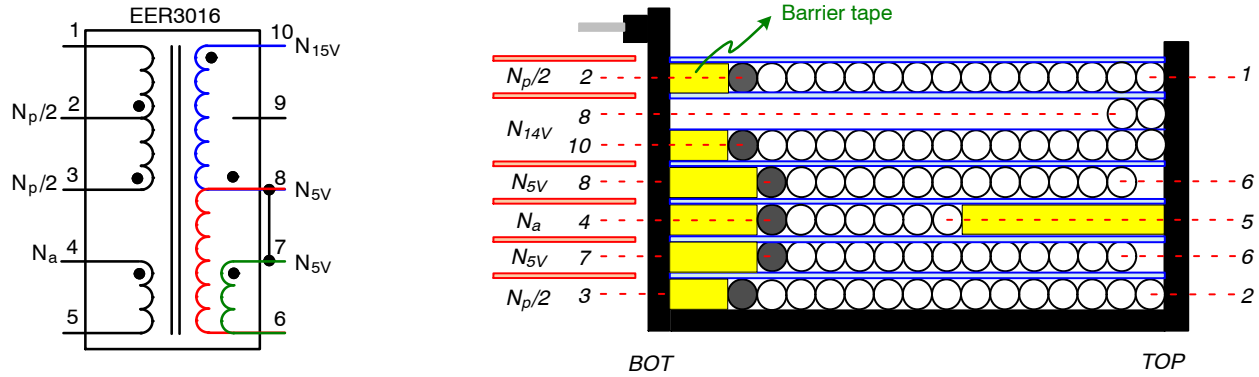

Figure 26. Schematic of Transformer

## Winding Specification

Table 3. WINDING SPECIFICATION

	Pin (S → F)	Wire	Turns	Winding Method	Barrier Tape		
					TOP	BOT	Ts
$N_p/2$	3 → 2	0.25 $\phi$ x 1	21	Solenoid Winding		2.0 mm	1
Insulation: Polyester Tape t = 0.025 mm, 2 Layers							
$N_{5V}$	7 → 6	0.4 $\phi$ x 2 (TIW)	3	Solenoid Winding		3.0 mm	1
Insulation: Polyester Tape t = 0.025 mm, 2 Layers							
$N_a$	4 → 5	0.2 $\phi$ x 1	7	Solenoid Winding	4.0 mm	3.0 mm	1
Insulation: Polyester Tape t = 0.025 mm, 2 Layers							
$N_{5V}$	8 → 6	0.4 $\phi$ x 2 (TIW)	3	Solenoid Winding		3.0 mm	1
Insulation: Polyester Tape t = 0.025 mm, 2 Layers							
$N_{14V}$	10 → 8	0.4 $\phi$ x 2 (TIW)	5	Solenoid Winding		2.0 mm	1
Insulation: Polyester Tape t = 0.025 mm, 2 Layers							
$N_p/2$	2 → 1	0.25 $\phi$ x 1	21	Solenoid Winding		2.0 mm	1
Insulation: Polyester Tape t = 0.025 mm, 2 Layers							

## Electrical Characteristics

Table 4. ELECTRICAL CHARACTERISTICS

	Pin	Specification	Remark
Inductance	1 – 3	900 $\mu$ H $\pm$ 7%	67 kHz, 1 V
Leakage	1 – 3	15 $\mu$ H Maximum	Short All Other Pins

## Core & Bobbin

- Core: EER3016 ( $A_e = 109.7 \text{ mm}^2$ )

- Bobbin: EER3016

# FSGM300N

## Bill of Materials

Table 5. Bill of Materials

Part #	Value	Note
<b>Fuse</b>		
F101	250 V 2 A	
<b>NTC</b>		
NTC101	5D-9	DSC
<b>Resistor</b>		
R101	1.5 M $\Omega$ , J	1 W
R102	68 k $\Omega$ , J	1/2 W
R103	43 k $\Omega$ , J	1 W
R201	620 $\Omega$ , F	1/4 W, 1%
R202	1.2 k $\Omega$ , F	1/4 W, 1%
R203	18 k $\Omega$ , F	1/4 W, 1%
R204	8 k $\Omega$ , F	1/4 W, 1%
R205	8 k $\Omega$ , F	1/4 W, 1%
<b>IC</b>		
FSGM300N	FSGM300N	ON Semiconductor
IC201	KA431LZ	ON Semiconductor
IC301	FOD817B	ON Semiconductor
<b>Diode</b>		
D101	1N4007	Vishay
D102	UF4007	Vishay
ZD101	1N4750	Vishay
D201	MBRF10H100	ON Semiconductor
D202	MBRF1060	ON Semiconductor
BD101	2KBP06	Vishay

Part #	Value	Note
<b>Capacitor</b>		
C101	220 nF / 275 V	Box (Pilkor)
C102	150 nF / 275 V	Box (Pilkor)
C103	100 $\mu$ F / 400 V	Electrolytic (SamYoung)
C104	3.3 nF / 630 V	Film (Sehwa)
C105	27 nF / 100 V	Film (Sehwa)
C106	220 nF	SMD (2012)
C107	47 $\mu$ F / 50 V	Electrolytic (SamYoung)
C201	1000 $\mu$ F / 25 V	Electrolytic (SamYoung)
C202	1000 $\mu$ F / 25 V	Electrolytic (SamYoung)
C203	2200 $\mu$ F / 10 V	Electrolytic (SamYoung)
C204	1000 $\mu$ F / 16 V	Electrolytic (SamYoung)
C205	47 nF / 100 V	Film (Sehwa)
C301	4.7 nF / Y2	Y-cap (Samhwa)
<b>Inductor</b>		
LF101	30 mH	Line filter 0.5 $\emptyset$
L201	5 $\mu$ H	5 A Rating
L202	5 $\mu$ H	5 A Rating
<b>Transformer</b>		
T101	900 $\mu$ H	

SENSEFET is registered trademark of Semiconductor Components Industries, LLC (SCILLC) or its subsidiaries in the United States and/or other countries.

# MECHANICAL CASE OUTLINE PACKAGE DIMENSIONS

ON Semiconductor®

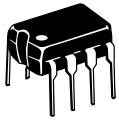

SCALE 1:1

PDIP-8  
CASE 626-05  
ISSUE P

DATE 22 APR 2015

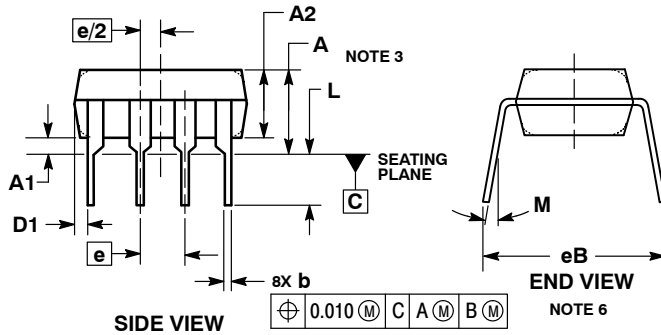
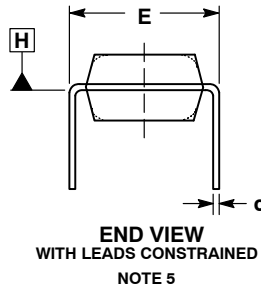
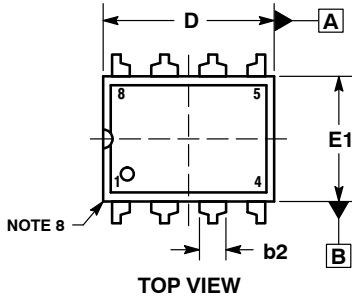

NOTES:

1. DIMENSIONING AND TOLERANCING PER ASME Y14.5M, 1994.
2. CONTROLLING DIMENSION: INCHES.
3. DIMENSIONS A, A1 AND L ARE MEASURED WITH THE PACKAGE SEATED IN JEDEC SEATING PLANE GAUGE GS-3.
4. DIMENSIONS D, D1 AND E1 DO NOT INCLUDE MOLD FLASH OR PROTRUSIONS. MOLD FLASH OR PROTRUSIONS ARE NOT TO EXCEED 0.10 INCH.
5. DIMENSION E IS MEASURED AT A POINT 0.015 BELOW DATUM PLANE H WITH THE LEADS CONSTRAINED PERPENDICULAR TO DATUM C.
6. DIMENSION eB IS MEASURED AT THE LEAD TIPS WITH THE LEADS UNCONSTRAINED.
7. DATUM PLANE H IS COINCIDENT WITH THE BOTTOM OF THE LEADS, WHERE THE LEADS EXIT THE BODY.
8. PACKAGE CONTOUR IS OPTIONAL (ROUNDED OR SQUARE CORNERS).

DIM	INCHES		MILLIMETERS	
	MIN	MAX	MIN	MAX
A	----	0.210	----	5.33
A1	0.015	----	0.38	----
A2	0.115	0.195	2.92	4.95
b	0.014	0.022	0.35	0.56
b2	0.060 TYP		1.52 TYP	
C	0.008	0.014	0.20	0.36
D	0.355	0.400	9.02	10.16
D1	0.005	----	0.13	----
E	0.300	0.325	7.62	8.26
E1	0.240	0.280	6.10	7.11
e	0.100 BSC		2.54 BSC	
eB	----	0.430	----	10.92
L	0.115	0.150	2.92	3.81
M	----	10°	----	10°

GENERIC MARKING DIAGRAM\*

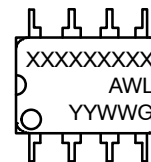

- XXXX = Specific Device Code
- A = Assembly Location
- WL = Wafer Lot
- YY = Year
- WW = Work Week
- G = Pb-Free Package

\*This information is generic. Please refer to device data sheet for actual part marking. Pb-Free indicator, "G" or microdot "▪", may or may not be present.

- STYLE 1:  
PIN 1. AC IN  
2. DC + IN  
3. DC - IN  
4. AC IN  
5. GROUND  
6. OUTPUT  
7. AUXILIARY  
8. V<sub>CC</sub>

DOCUMENT NUMBER:	98ASB42420B	Electronic versions are uncontrolled except when accessed directly from the Document Repository. Printed versions are uncontrolled except when stamped "CONTROLLED COPY" in red.
DESCRIPTION:	PDIP-8	PAGE 1 OF 1

ON Semiconductor and are trademarks of Semiconductor Components Industries, LLC dba ON Semiconductor or its subsidiaries in the United States and/or other countries. ON Semiconductor reserves the right to make changes without further notice to any products herein. ON Semiconductor makes no warranty, representation or guarantee regarding the suitability of its products for any particular purpose, nor does ON Semiconductor assume any liability arising out of the application or use of any product or circuit, and specifically disclaims any and all liability, including without limitation special, consequential or incidental damages. ON Semiconductor does not convey any license under its patent rights nor the rights of others.

**onsemi**, **Onsemi**, and other names, marks, and brands are registered and/or common law trademarks of Semiconductor Components Industries, LLC dba "**onsemi**" or its affiliates and/or subsidiaries in the United States and/or other countries. **onsemi** owns the rights to a number of patents, trademarks, copyrights, trade secrets, and other intellectual property. A listing of **onsemi**'s product/patent coverage may be accessed at [www.onsemi.com/site/pdf/Patent-Marking.pdf](http://www.onsemi.com/site/pdf/Patent-Marking.pdf). **onsemi** reserves the right to make changes at any time to any products or information herein, without notice. The information herein is provided "as-is" and **onsemi** makes no warranty, representation or guarantee regarding the accuracy of the information, product features, availability, functionality, or suitability of its products for any particular purpose, nor does **onsemi** assume any liability arising out of the application or use of any product or circuit, and specifically disclaims any and all liability, including without limitation special, consequential or incidental damages. Buyer is responsible for its products and applications using **onsemi** products, including compliance with all laws, regulations and safety requirements or standards, regardless of any support or applications information provided by **onsemi**. "Typical" parameters which may be provided in **onsemi** data sheets and/or specifications can and do vary in different applications and actual performance may vary over time. All operating parameters, including "Typicals" must be validated for each customer application by customer's technical experts. **onsemi** does not convey any license under any of its intellectual property rights nor the rights of others. **onsemi** products are not designed, intended, or authorized for use as a critical component in life support systems or any FDA Class 3 medical devices or medical devices with a same or similar classification in a foreign jurisdiction or any devices intended for implantation in the human body. Should Buyer purchase or use **onsemi** products for any such unintended or unauthorized application, Buyer shall indemnify and hold **onsemi** and its officers, employees, subsidiaries, affiliates, and distributors harmless against all claims, costs, damages, and expenses, and reasonable attorney fees arising out of, directly or indirectly, any claim of personal injury or death associated with such unintended or unauthorized use, even if such claim alleges that **onsemi** was negligent regarding the design or manufacture of the part. **onsemi** is an Equal Opportunity/Affirmative Action Employer. This literature is subject to all applicable copyright laws and is not for resale in any manner.

## ADDITIONAL INFORMATION

### TECHNICAL PUBLICATIONS:



Technical Library: [www.onsemi.com/design/resources/technical-documentation](http://www.onsemi.com/design/resources/technical-documentation)  
onsemi Website: [www.onsemi.com](http://www.onsemi.com)

### ONLINE SUPPORT: [www.onsemi.com/support](http://www.onsemi.com/support)

For additional information, please contact your local Sales Representative at [www.onsemi.com/support/sales](http://www.onsemi.com/support/sales)

## Looking for pricing, stock, or lifecycle information?

Click below to explore more details on WIN SOURCE:

-  [View FSGM300N on WIN SOURCE](#)
-  [Fairchild/ON Semiconductor Information](#)

## Optimize Your Supply Chain with WIN SOURCE Solutions

-  Global Sourcing Solution
-  Obsolete Management
-  Cost Control Management
-  Shortage Management
-  Alternative Solution
-  Excess Inventory Management