



**THE DATASHEET OF
GP1A30R1J00F**



REFERENCE

SHARP

SPEC.No. ED-09G003
ISSUE July 23, 2009

SYSTEM DEVICE DIVISION I
ELECTRONIC COMPONENTS AND DEVICES GROUP
SHARP CORPORATION

SPECIFICATION

DEVICE SPECIFICATION FOR
PHOTOINTERRUPTER
MODEL No. GP1A30R1J00F

Specified for

Enclosed please find copies of the Specifications which consists of 13 pages including cover.
This specification sheets and attached sheets shall be both side copy.
After confirmation of the contents, please be sure to send back copies of the Specifications
with approving signature on each.

CUSTOMER'S APPROVAL

PRESENTED

DATE

DATE

BY

BY



M. Kubo,
Department General Manager of
Development Dept. IV
System Device Division I
Electronic Components and Devices Group
SHARP CORPORATION

REFERENCE

Product name : PHOTOINTERRUPTER

Model No. : GP1A30R1J00F

1. These specification sheets include materials protected under copyright of Sharp Corporation ("Sharp"). Please do not reproduce or cause anyone to reproduce them without Sharp's consent.
2. When using this product, please observe the absolute maximum ratings and the instructions for use outlined in these specification sheets, as well as the precautions mentioned below. Sharp assumes no responsibility for any damage resulting from use of the product which does not comply with the absolute maximum ratings and the instructions included in these specification sheets, and the precautions mentioned below.

(Precautions)

- (1) This product is designed for use in the following application areas ;

{	<ul style="list-style-type: none"> • OA equipment • Audio visual equipment • Home appliances • Telecommunication equipment (Terminal) • Measuring equipment • Tooling machines • Computers 	}
---	---	---

If the use of the product in the above application areas is for equipment listed in paragraphs (2) or (3), please be sure to observe the precautions given in those respective paragraphs.

- (2) Appropriate measures, such as fail-safe design and redundant design considering the safety design of the overall system and equipment, should be taken to ensure reliability and safety when this product is used for equipment which demands high reliability and safety in function and precision, such as ;

{	<ul style="list-style-type: none"> • Transportation control and safety equipment (aircraft, train, automobile etc.) • Traffic signals • Gas leakage sensor breakers • Rescue and security equipment • Other safety equipment 	}
---	---	---

- (3) Please do not use this product for equipment which require extremely high reliability and safety in function and precision, such as ;

{	<ul style="list-style-type: none"> • Space equipment • Telecommunication equipment (for trunk lines) • Nuclear power control equipment • Medical equipment 	}
---	--	---

- (4) Please contact and consult with a Sharp sales representative if there are any questions regarding interpretation of the above three paragraphs.

3. Please contact and consult with a Sharp sales representative for any questions about this product.

1. Application

This specification applies to the outline and characteristics of transmissive type photointerrupter, Model No. GP1A30R1J00F.

REFERENCE

2. Outline

Refer to the attached drawing No. CY14652i02. Page 4.

3. Ratings and characteristics

- Refer to the attached sheet, Page 5 to 8.
- Resolution : Disk slit pitch = 0.704mm
- Output waveform : Digital 2-phase (Phase A and Phase B)

4. Reliability

Refer to the attached sheet, Page 9.

5. Outgoing inspection

Refer to the attached sheet, Page 10.

6. Supplements

6.1 Parts

Refer to the attached sheet, Page 11.

6.2 Packing

Refer to the attached drawing No. CY14654i09, Page 12.

6.3 ODS materials

This product shall not contain the following materials.

Also, the following materials shall not be used in the production process for this product.

Materials for ODS : CFC_s, Halon, Carbon tetrachloride, 1.1.1-Trichloroethane (Methyl chloroform)

6.4 Specified brominated flame retardants

Specified brominated flame retardants (PBB and PBDE) are not used in this device at all.

6.5 Compliance with each regulation

6.5.1 The RoHS directive(2002/95/EC)

This product complies with the RoHS directive(2002/95/EC)

Object substances: mercury,lead, cadmium,hexavalent chromium,polybrominated biphenyls (PBB)
and polybrominated diphenyl ethers (PBDE)

6.5.2 Content of six substances specified in Management Method for Control of Pollution Caused by Electronic Information Products Regulation (Chinese : 电子信息产品污染控制管理办法).

Category	Toxic and hazardous substances					
	Lead (Pb)	Mercury (Hg)	Cadmium (Cd)	Hexavalent chromium (Cr ⁶⁺)	Polybrominated biphenyls (PBB)	Polybrominated diphenyl ethers (PBDE)
Photointerrupter	✓	✓	✓	✓	✓	✓

✓ : indicates that the content of the toxic and hazardous substance in all the homogeneous materials of the part is below the concentration limit requirement as described in SJ/T 11363-2006 standard.

6.6 Product mass : Approximately 0.8g

6.7 Country of origin : Japan, China, Indonesia

REFERENCE

7. Notes

7.1 The recommendation conditions of forward current:

This product is designed in consideration of using this product under the condition of typical $I_F=30\text{mA}$ as a standard.

7.2 In order to stabilize power supply line, it is recommended to have a by-pass capacitor of $0.01\mu\text{F}$ or more between V_{cc} and GND near the device.

7.3 When tightening this product with the screw, please use the M2 machine screw in combination with the washer.

The recommended tightening torque is 0.2 to $0.3\text{ N} \cdot \text{m}$.

However, this recommended tightening torque is the reference value because the tightening torque varies according to the screw and the bolted joint.

Before tightening the screw, please certainly confirm the tightening strength of this product and the object on which this product is mounted. Also, when tightening the screw with the tools such as the screw-driver, if the pushing force by the screw-driver is too strong, the damage of the product performances such as the break of the holder's mounting hole may be caused by the application of the external force.

Therefore, please be careful not to apply such a force to this product.

7.4 Cleaning conditions :

- (1) Solvent cleaning : Solvent temperature 45°C or less
Immersion 3 min. or less
- (2) Ultrasonic cleaning : The effect to device by ultrasonic cleaning differs by cleaning bath size, ultrasonic power output, cleaning time, PCB size or device mounting condition etc.
Please test it in actual using condition and confirm that doesn't occur any defect before starting the ultrasonic cleaning.
- (3) Applicable solvent : Ethyl alcohol, Methyl alcohol, Isopropyl alcohol

7.5 Soldering

To solder onto lead pins, solder at 260°C for 5 seconds or less.

Please take care not to let any external force exert on lead pins when soldering or just after soldering.

Please don't do soldering with preheating, and please don't do soldering by reflow.

7.6 OPIC chip due to micro design is easily affected by the Electro static discharge.

At operating, in order to prevent the destruction and the defect of characteristics by Electro static discharge, please take a general countermeasure of the Electro static discharge.

7.7 Storage and usage environment

Polycarbonate is used as the case material of this product.

If polycarbonate contacts with the hot liquid and the alkaline solution (alkaline atmosphere), polycarbonate is hydrolyzed. Therefore, please do not store and use this product in such an environment.

7.8 Disk design for GP1A30R1J00F

Given the disk resolution (N), R_o (distance between the disk center and half of a slit) and S_1, S_2 (installing position of encoder) will be provided by the following equations.

$$R_o = N / 120 \times 13.45 \text{ (Unit : mm)}$$

$$S_1 = R_o - 1.765 \text{ (Unit : mm)}$$

$$S_2 = S_1 + 6.7 \text{ (Unit : mm)}$$

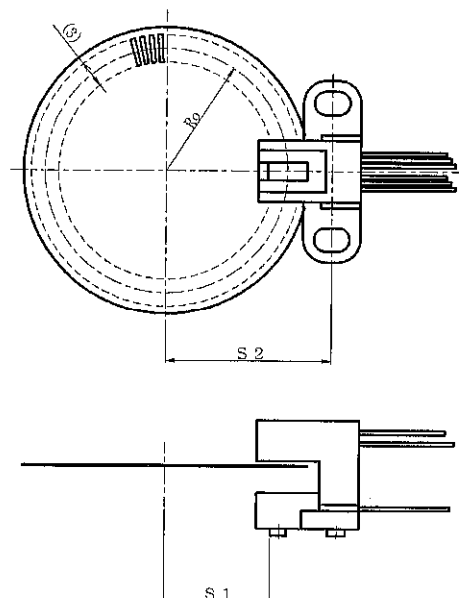

REFERENCE

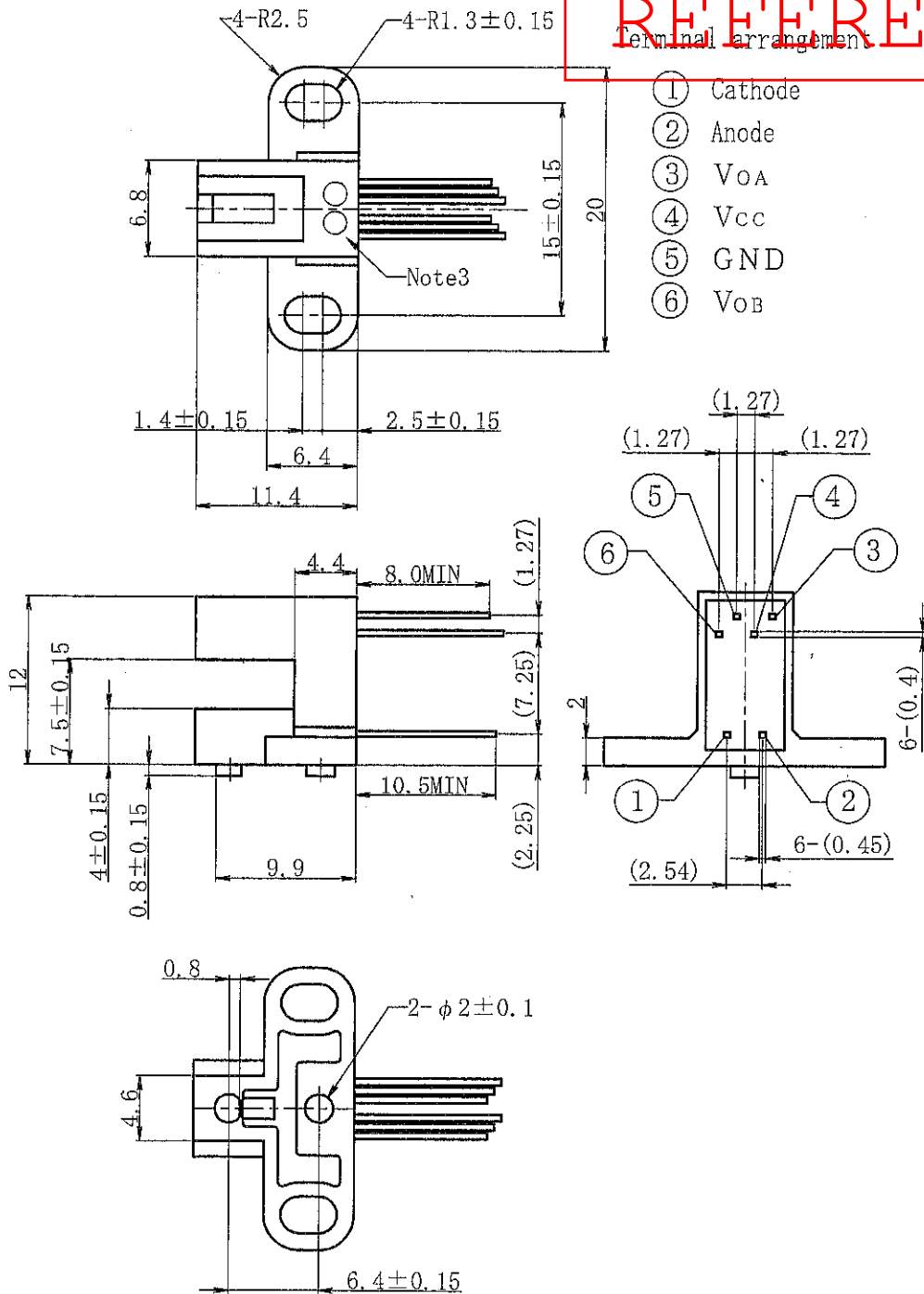

- ① Cathode
- ② Anode
- ③ V_{OA}
- ④ V_{CC}
- ⑤ GND
- ⑥ V_{OB}

Note

- 1) Unspecified tolerances shall be ±0.2.
- 2) Dimensions in parenthesis are shown for reference.
- 3) Date code shall be displayed in 2 digits.

3. Ratings and characteristics

3.1 GP1A30R1J00F block diagram

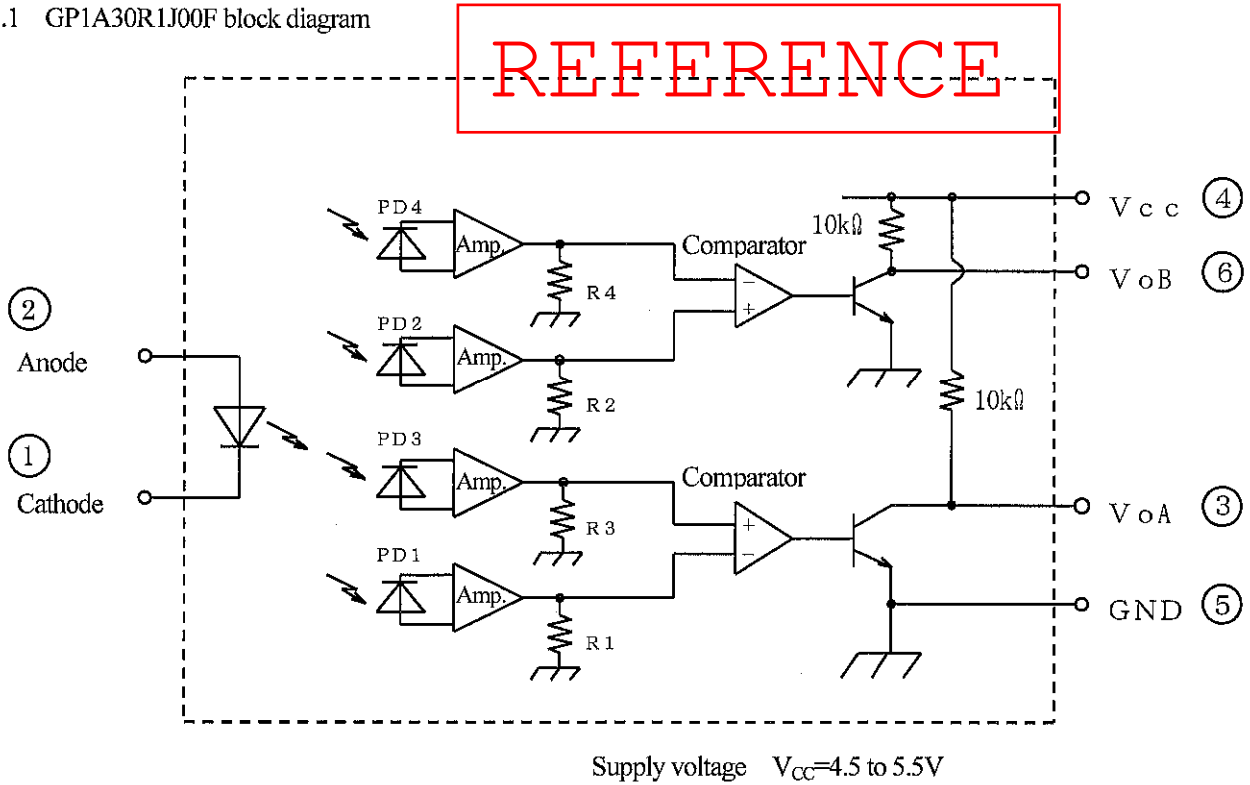

3.2 Absolute maximum ratings

$T_a=25^{\circ}C$

Parameter		Symbol	Rating	Unit
Input	Forward current *1	I_F	50	mA
	Reverse voltage	V_R	6	V
Output	Supply voltage	V_{CC}	7	V
	Low level output current	I_{OL}	20	mA
	Power dissipation *1	P_o	250	mW
Operating temperature		T_{opr}	0 to +70	$^{\circ}C$
Storage temperature		T_{stg}	-40 to +80	$^{\circ}C$
Soldering temperature *2		T_{sol}	260	$^{\circ}C$

*1 The derating factors of absolute maximum ratings due to ambient temperature are shown in Fig. 1, 2.

*2 Soldering time : 5s or less

REFERENCE

3.3 Electro-optical characteristics

Ta=25°C

Parameter		Symbol	Conditions	MIN.	TYP.	MAX.	Unit
Input	Forward voltage	V _F	I _F =30mA	-	1.2	1.5	V
	Reverse current	I _R	V _R =3V	-	-	10	μA
Output	Operating supply voltage range	V _{CC}	-	4.5	5.0	5.5	V
	Low level output voltage	V _{OL}	V _{CC} =5V, I _F =30mA I _{OL} =8mA	-	0.1	0.4	V
	High level output voltage	V _{OH}	V _{CC} =5V, I _F =30mA	2.4	4.9	-	V
	Supply current	I _{CC}	V _{CC} =5V, I _F =30mA Phases A and B both at low level	-	5	20	mA
Transfer characteristics ※1	Duty	D _A	V _{CC} =5V I _F =30mA f=2.5kHz	20	50	80	%
		D _B					
	Response frequency	f _{max}		V _{CC} =5V, I _F =30mA	-	-	10

※1 The test condition is according to Fig.3 (CY14653i06)
Transfer characteristics value does not include any error of disk slit.

Note: It is recommended that the GP1A30R1J00F be used under the condition of typical I_F=30mA for which it is designed.

3.4 Output waveform

Disk rotational direction: Counterclockwise when seen from the detector side.

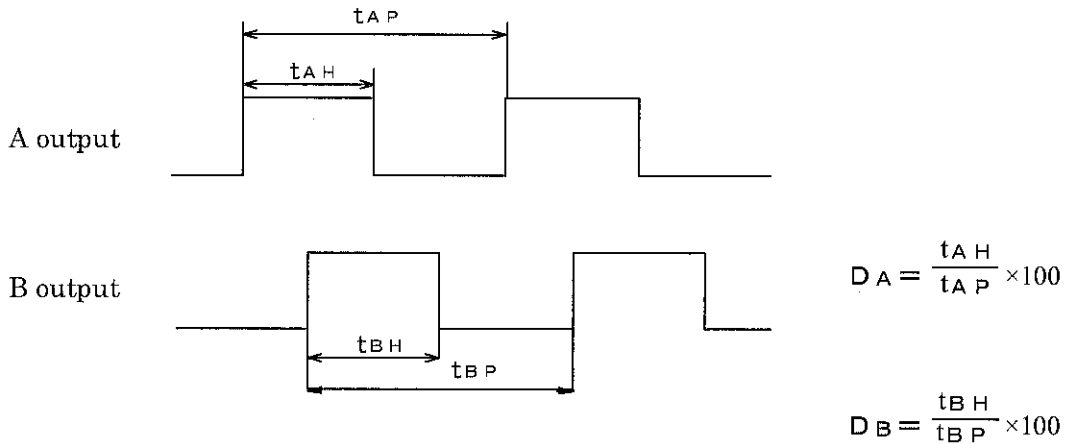

Disk rotational direction: Clockwise when seen from the detector side.

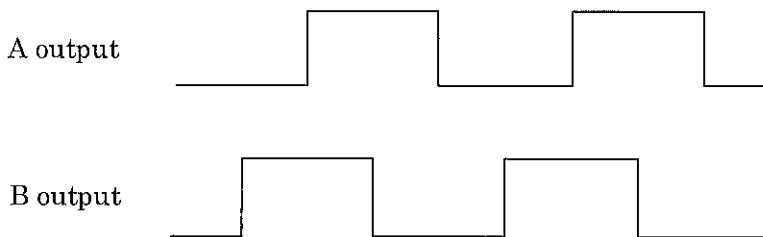

Fig.1 Forward current vs. ambient temperature

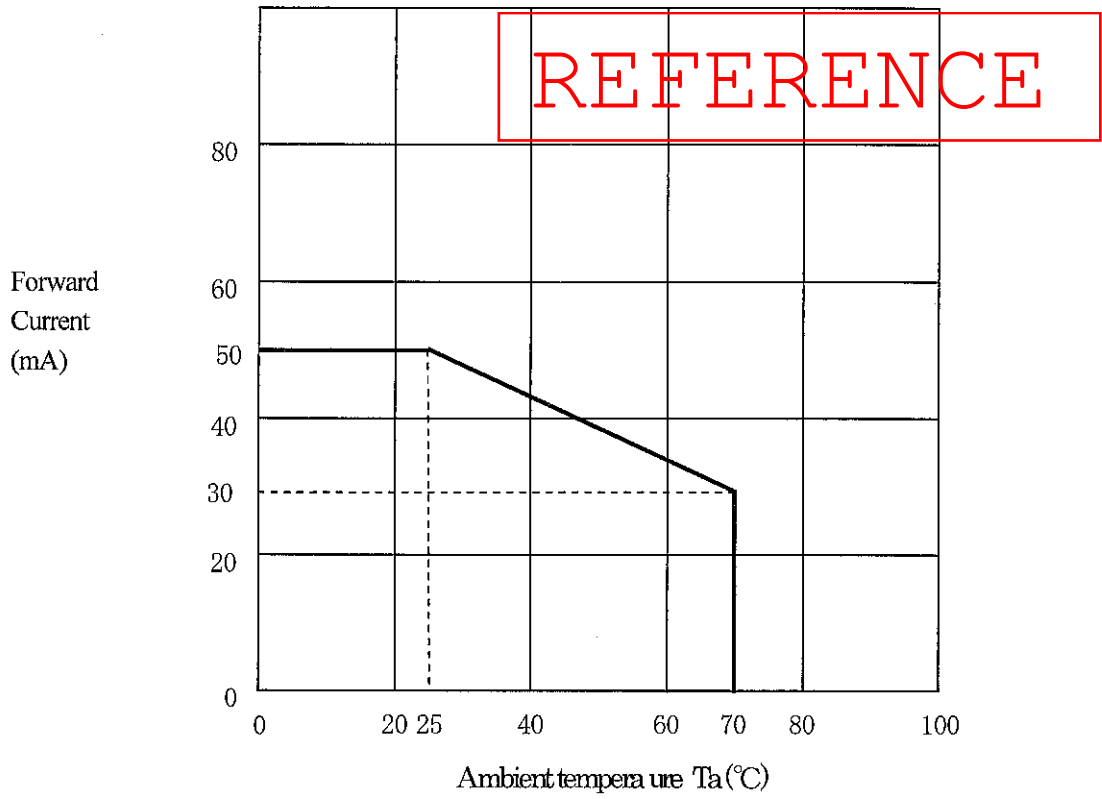

Fig.2 Output power dissipation vs. ambient temperature

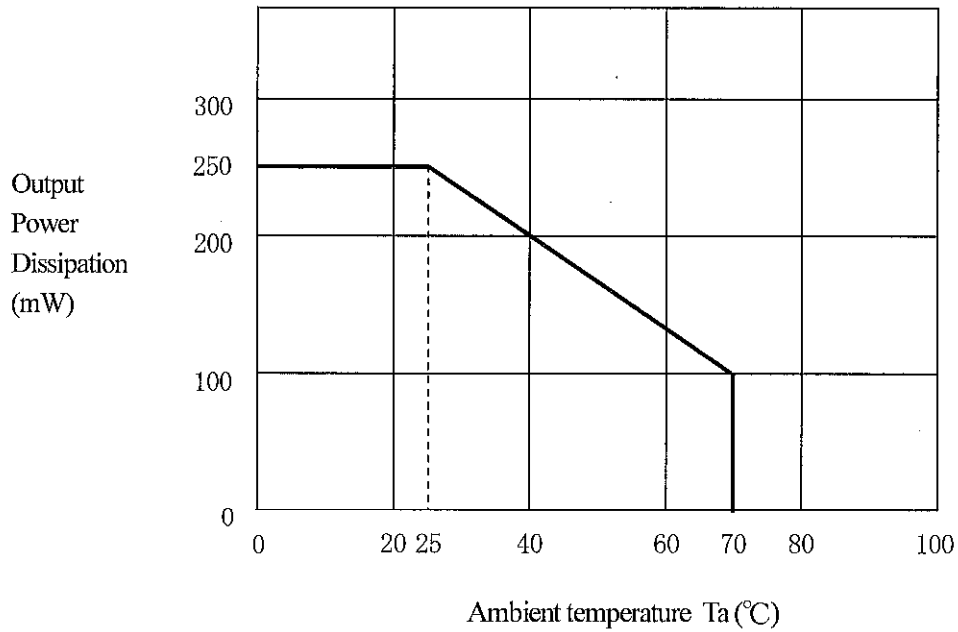
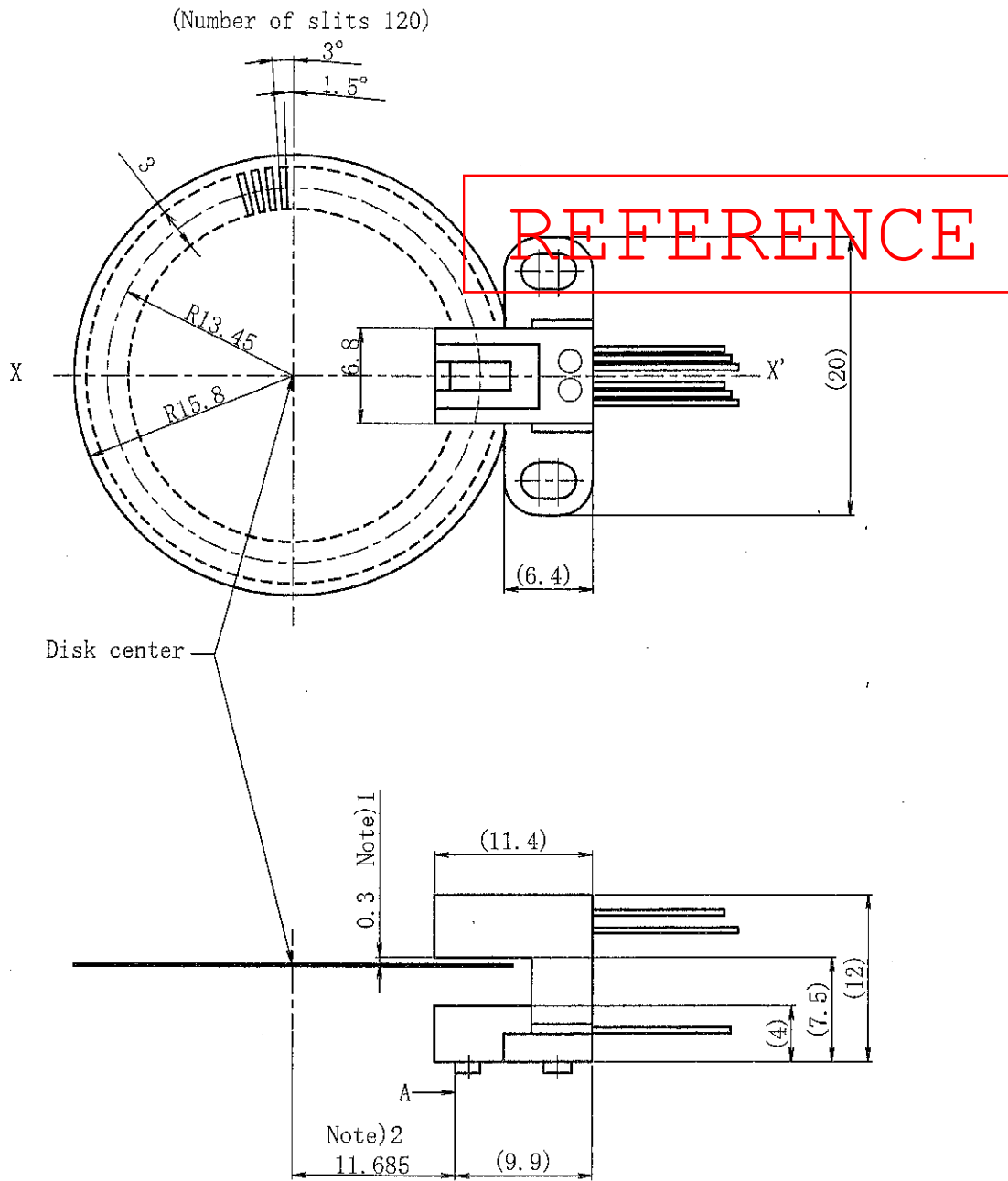

Fig.3 GP1A30R1J00F Test Condition (Drawing No.CY14653i06)

Scale : Free

Unit : 1/1mm



Note

- 1) Distance between disk surface and case surface in the detector side is 0.3mm.
- 2) Encoder positioning pin is positioned on X-X' axis. Distance between center of disk and portion A of positioning pin is 11.685mm.
- 3) Center of disk slit is R13.45mm.

4. Reliability

The reliability of products shall satisfy items listed below.

Confidence level : 90%

LTPD : 10 or 20

Test Items	Test Conditions	Failure Judgement Criteria	Samples (n)
			Defective (c)
Temperature cycling	1 cycle -40°C to +80°C (30min) (30min) 20 cycles test	$V_F \geq U \times 1.2$	n=22, c=0
High temp. and high humidity storage	+60°C, 90%RH, 500h	$I_R \geq U \times 2$	n=22, c=0
High temp. storage	+80°C, 500h	$V_{OL} \geq U \times 1.2$	n=22, c=0
Low temp. storage	-40°C, 500h	$V_{OH} \leq L \times 0.8$	n=22, c=0
Operation life	$I_F=30\text{mA}$, $V_{CC}=5\text{V}$, $T_a=25^\circ\text{C}$, 500h	$I_{CC} \geq U \times 1.2$	n=22, c=0
Mechanical shock	15000m/s ² , 0.5ms 3 times/±X, ±Y, ±Z direction	Duty : Shall be within the specification values.	n=11, c=0
Variable frequency vibration	100 to 2000 to 100Hz/4min 4 times/X, Y, Z direction 200m/s ²		n=11, c=0
Terminal strength (Tension)	Weight: 5N 30s/each terminal		n=11, c=0
Terminal strength (Bending)	Weight: 5N 0° →90° →0° →-90° →0° 1time bending		n=11, c=0
Soldering heat	260°C, 5s	L: Lower specification limit	n=11, c=0
Solderability	245 ±3°C, 5s	*1	n=11, c=0

* Test conditions shall be based upon the specification.

*1 Solder shall adhere at less than 95% area of immersed portion of lead.

The alloy composition of solder used for lead free should be Sn-3.0Ag-0.5Cu.

Flux used for precleaning should be equivalent to EC-19S-8(TAMURA KAKEN CORPORATION).

5. Outgoing inspection

5.1 Inspection items

- (1) Electrical characteristic
 V_F , I_R , V_{OL} , V_{OH} , I_{CC} , Duty
- (2) Appearance

REFERENCE

5.2 Sampling method and Inspection level

A single sampling plan, normal inspection level II based on ISO 2859 is applied.

The AQL according to the inspection items are shown below.

Defect	Inspection item	AQL
Major defect	Electrical characteristics defect Unreadable marking	0.1%
Minor defect	Appearance defect except the above mentioned	0.25%

6. Supplements

6.1 Parts

This product uses the below parts.

6.1.1 Light detector (Quantity : 1)

(Using a silicon photodiode as light detecting portion, and a bipolar IC as signal processing circuit.)

Type	Maximum sensitivity wavelength (nm)	Sensitivity wavelength (nm)	Response time (μ s)
Photodiode	900	400 to 1200	100

REFERENCE

6.1.2 Light emitter (Quantity : 1)

Type	Material	Maximum light emitting wavelength (nm)
Infrared light emitting diode (Non-coherent)	GaAlAs	940

6.1.3 Material

Holder	Lead flame finish
Black polycarbonate resin	Solder dip (Sn-Ag-Cu)

6.1.4 Others

This product shall not be radiation flux proof.

Laser generator is not used.

6.2 Packing (Drawing No.:CY14654i09)

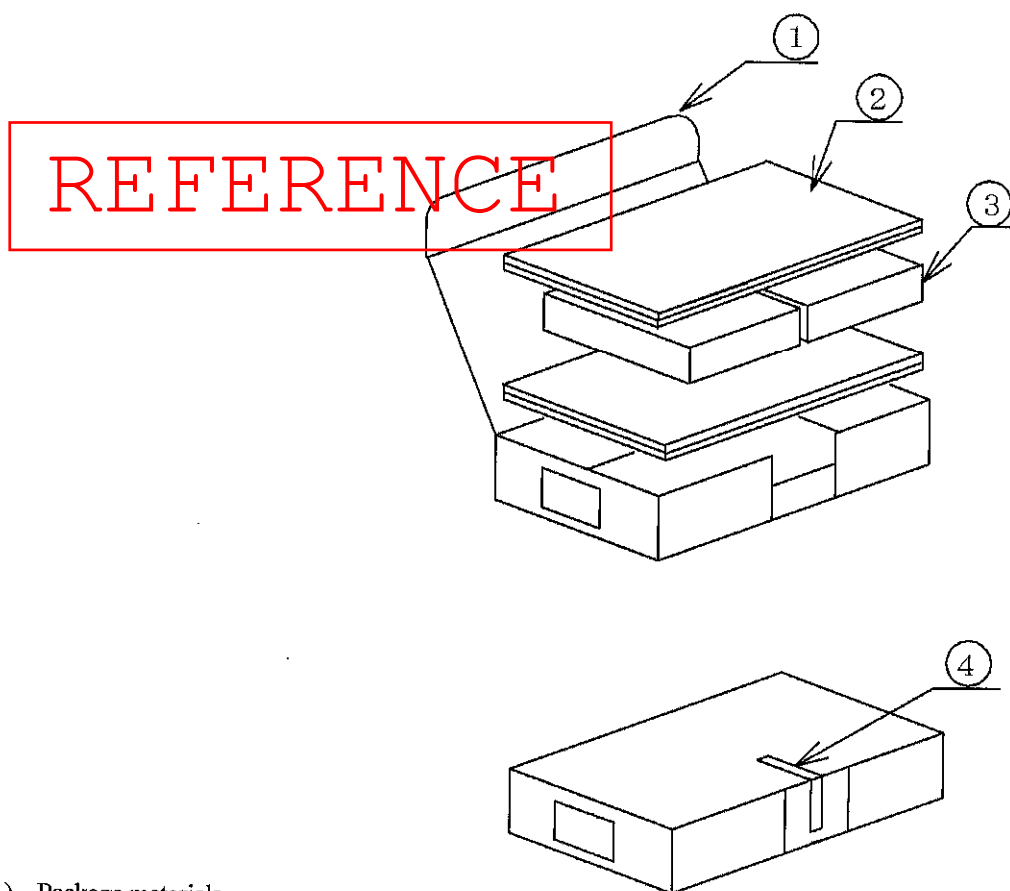

1) Package materials

No	Name	Quantity
1	Device case	1
2	Cushioning material	4
3	Antistatic electricity bag	2
4	Cellophane tape	-

2) Packaging numbers

MAX. 50 pieces per bag

MAX. 100 pieces per case

3) Indication items

The contents of the carton indication conforms to EIAJ C-3 and the following items are indicated.

Model No., Internal production control name, Quantity, Packing date, Corporate name, Country of origin

4) Package specifications

1.Put 50 devices into antistatic electricity bag and seal with cellophane tape.

2.Put two sets of a thing of above 1 to a device case.

In addition,spread two pieces of cushioning material at top and bottom.

3.Seal a device case with cellophane tape.

5) Regular packing mass

(Excluding fractions, however above packing material, packing count, packing style)

• Approx. 0.2kg

Looking for pricing, stock, or lifecycle information?

Click below to explore more details on WIN SOURCE:

-  [View GP1A30R1J00F on WIN SOURCE](#)
-  [Sharp Microelectronics Information](#)

Optimize Your Supply Chain with WIN SOURCE Solutions

-  Global Sourcing Solution
-  Obsolete Management
-  Cost Control Management
-  Shortage Management
-  Alternative Solution
-  Excess Inventory Management