



**THE DATASHEET OF
GP1A30RJ000F**



REFERENCE

SPEC. No. ED-04G026
ISSUE March 24, 2004

SHARP

OPTO-ELECTRONIC DEVICES DIVISION
ELECTRONIC COMPONENTS GROUP
SHARP CORPORATION

SPECIFICATION

DEVICE SPECIFICATION FOR

PHOTOINTERRUPTER

MODEL No.

GP1A30RJ000F

Specified for

Enclosed please find copies of the Specifications which consists of 11 pages including cover.
After confirmation of the contents, please be sure to send back copies of the Specifications
with approving signature on each.

CUSTOMER'S APPROVAL

DATE

BY

PRESENTED

DATE

BY

27.0

H. Ogura,
Department General Manager of
Engineering Dept., III
Opto-Electronic Devices Div.
ELECOM Group
SHARP CORPORATION

REFERENCEProduct name : PHOTOINTERRUPTERModel No. : GP1A30RJ000F

1. These specification sheets include materials protected under copyright of Sharp Corporation ("Sharp"). Please do not reproduce or cause anyone to reproduce them without Sharp's consent.
2. When using this product, please observe the absolute maximum ratings and the instructions for use outlined in these specification sheets, as well as the precautions mentioned below. Sharp assumes no responsibility for any damage resulting from use of the product which does not comply with the absolute maximum ratings and the instructions included in these specification sheets, and the precautions mentioned below.

(Precautions)

- (1) This product is designed for use in the following application areas ;

{	• OA equipment • Audio visual equipment • Home appliances
	• Telecommunication equipment (Terminal) • Measuring equipment
	• Tooling machines • Computers

If the use of the product in the above application areas is for equipment listed in paragraphs (2) or (3), please be sure to observe the precautions given in those respective paragraphs.

- (2) Appropriate measures, such as fail-safe design and redundant design considering the safety design of the overall system and equipment, should be taken to ensure reliability and safety when this product is used for equipment which demands high reliability and safety in function and precision, such as ;

{	• Transportation control and safety equipment (aircraft, train, automobile etc.)
	• Traffic signals • Gas leakage sensor breakers • Rescue and security equipment
	• Other safety equipment etc.

- (3) Please do not use this product for equipment which require extremely high reliability and safety in function and precision, such as ;

{	• Space equipment • Telecommunication equipment (for trunk lines)
	• Nuclear power control equipment • Medical equipment etc.

- (4) Please contact and consult with a Sharp sales representative if there are any questions regarding interpretation of the above three paragraphs.

3. Please contact and consult with a Sharp sales representative for any questions about this product.

REFERENCE

1. Application

This specification applies to the outline and characteristics of transmissive type photointerrupter, Model No. GP1A30RJ000F.

2. Outline

Refer to the attached drawing No. CY12002i02.

3. Ratings and characteristics

- Refer to the attached sheet, Page 4 to 7.
- Resolution : Disk slit pitch = 0.704mm
- Output waveform : Digital 2-phase (Phase A and Phase B)

4. Reliability

Refer to the attached sheet, Page 8.

5. Outgoing inspection

Refer to the attached sheet, Page 9.

6. Supplements

6.1 Parts

Refer to the attached sheet, Page 10.

6.2 ODS materials

This product shall not contain the following materials.

Also, the following materials shall not be used in the production process for this product.

Materials for ODS : CFCs, Halon, Carbon tetrachloride, 1,1,1-Trichloroethane (Methyl chloroform)

6.3 Brominated flame retardants

Specific brominated flame retardants such as the PBBO_S and PBB_S are not used in this device at all.

6.4 Lead content

This product dose not contain lead.

6.5 Product mass : Approximately 1.1g

7. Notes

7.1 It is recommended that the GP1A30RJ000F be used under the condition of typical $I_F=30\text{mA}$ for which it is designed.

7.2 In order to stabilize power supply line, connect a by-pass capacitor of more than $0.01\ \mu\text{F}$ between Vcc and GND near the device.

7.3 Tightening torque of set screw (M2) for mounting the GP1A30RJ000F shall be 6kg-cm (MAX.)

7.4 Cleaning conditions :

(1) Solvent cleaning : Solvent temperature 45°C or less

Immersion 3 min. or less

(2) Ultrasonic cleaning : The effect to device by ultrasonic cleaning differs by cleaning bath size, ultrasonic power output, cleaning time, PCB size or device mounting condition etc.

Please test it in actual using condition and confirm that doesn't occur any defect before starting the ultrasonic cleaning.

(3) Applicable solvent : Ethyl alcohol, Methyl alcohol, Isopropyl alcohol

7.5 Soldering

To solder onto lead pins, solder at 260°C for 5 seconds or less.

Please take care not to let any external force exert on lead pins when soldering or just after soldering.

Please don't do soldering by reflow.

7.6 Disk design for GP1A30RJ000F

Given the disk resolution (N), R_o (distance between the disk center and half of a slit) and S_1, S_2 (installing position of encoder) will be provided by the following equations.

$$R_o = N / 120 \times 13.45 \text{ (Unit : mm)}$$

$$S_1 = R_o - 1.765 \text{ (Unit : mm)}$$

$$S_2 = S_1 + 6.7 \text{ (Unit : mm)}$$

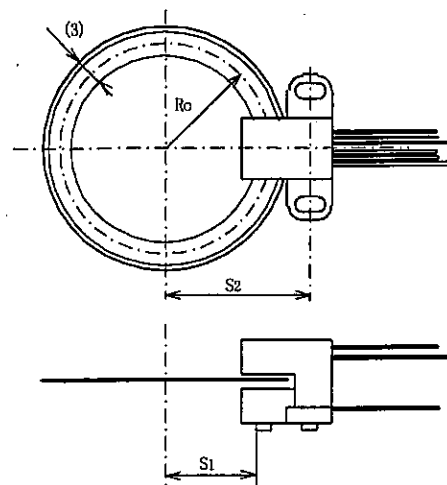

2 Outline (Drawing No. CY12002i02)

Scale : 2/1 Unit : mm

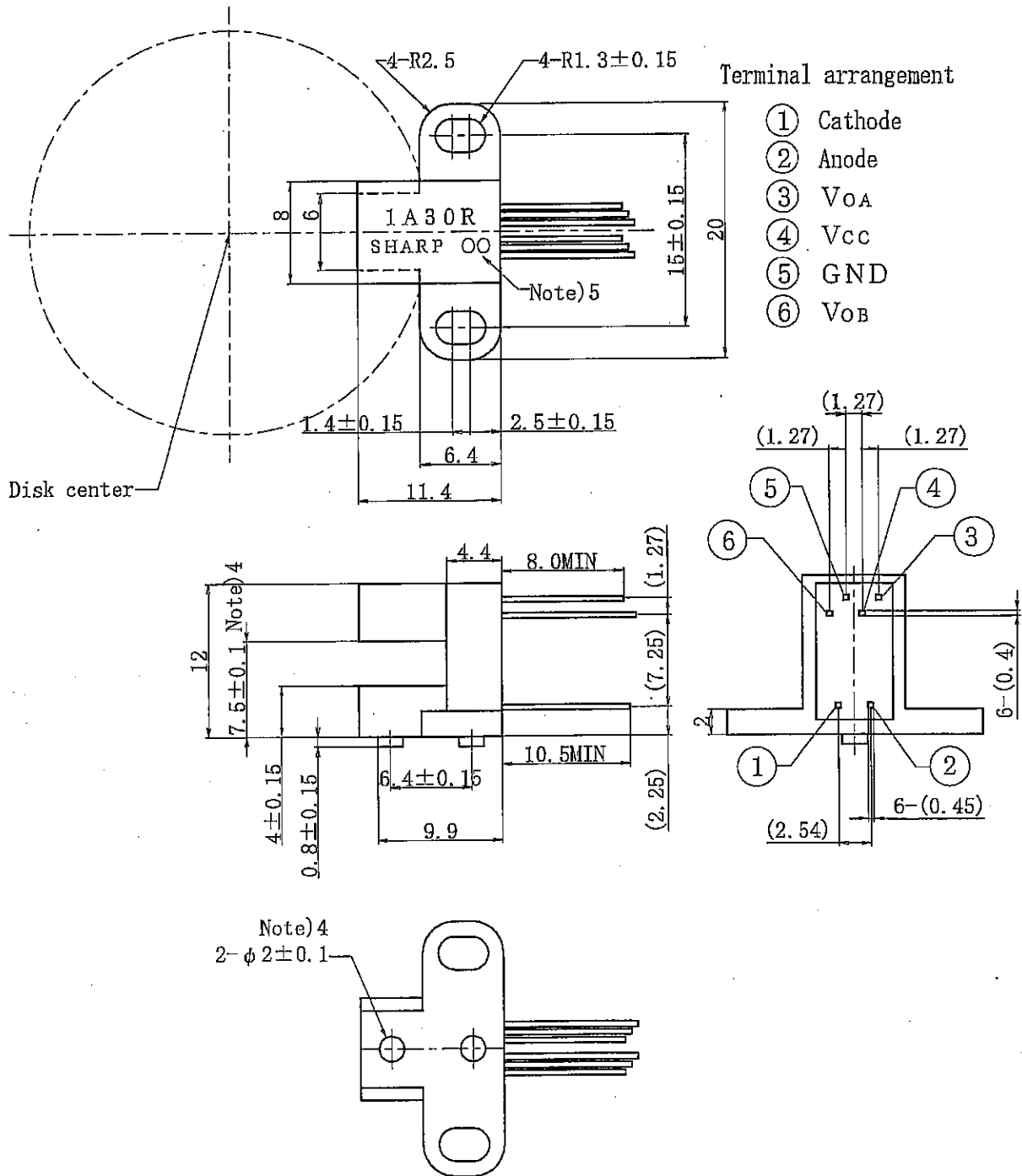

Note

- 1) Unspecified tolerances shall be ± 0.3.
- 2) Dimensions in parenthesis are shown for reference.
- 3) The disk is not included in this encoder module, GP1A30RJ000F.
- 4) The outline dimensions which affects electrical characteristics in outgoing inspection standard.
- 5) Date code shall be displayed in 2 digits.

REFERENCE

3. Ratings and characteristics

3.1 GPIA30RJ000F block diagram

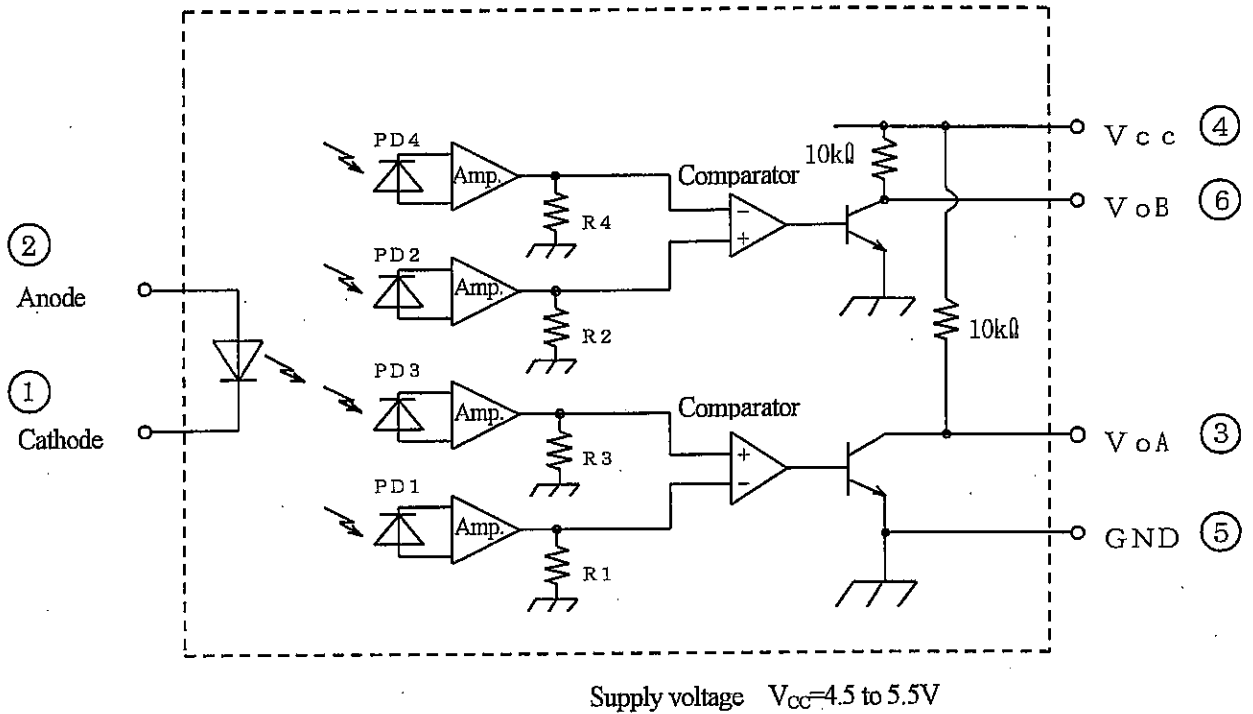

3.2 Absolute maximum ratings

$T_a=25^{\circ}C$

Parameter		Symbol	Rating	Unit
Input	Forward current *2	I_F	65	mA
	Peak forward current *1	I_{FM}	1	A
	Reverse voltage	V_R	6	V
	Power dissipation	P	100	mW
Output	Supply voltage	V_{CC}	7	V
	Low level output current	I_{OL}	20	mA
	Power dissipation *2	P_o	250	mW
Operating temperature		T_{opr}	0 to +70	$^{\circ}C$
Storage temperature		T_{stg}	-40 to +80	$^{\circ}C$
Soldering temperature *3		T_{sol}	260	$^{\circ}C$

*1 Pulse width $\leq 100 \mu s$, Duty ratio = 0.01

*2 The derating factors of absolute maximum ratings due to ambient temperature are shown in Fig. 1, 2.

*3 For 5s

REFERENCE

3.3 Electro-optical characteristics

(Unless otherwise specified Ta = 0 ~ 70°C)

Parameter		Symbol	Conditions	MIN.	TYP.	MAX.	Unit
Input	Forward voltage	V_F	$I_F=30\text{mA}$, $T_a=25^\circ\text{C}$	-	1.2	1.5	V
	Reverse current	I_R	$V_R=3\text{V}$, $T_a=25^\circ\text{C}$	-	-	10	μA
Output	Operating supply voltage range	V_{CC}	-	4.5	5.0	5.5	V
	Low level output voltage	V_{OL}	$V_{CC}=5\text{V}$, $I_F=30\text{mA}$ $I_{OL}=8\text{mA}$	-	0.1	0.4	V
	High level output voltage	V_{OH}	$V_{CC}=5\text{V}$, $I_F=30\text{mA}$	2.4	4.9	-	V
	Supply current	I_{CC}	$V_{CC}=5\text{V}$, $I_F=30\text{mA}$ Phases A and B both at low level	-	5	20	mA
Transfer characteristics ※1	Duty	D_A	$V_{CC}=5\text{V}$ $I_F=30\text{mA}$ $f=2.5\text{kHz}$	20	50	80	%
		D_B					
	Response frequency	f_{max}		$V_{CC}=5\text{V}$, $I_F=30\text{mA}$	-	-	5

※1 The test condition is according to Fig.3 (CY12003i06)

Transfer characteristics value does not include any error of disk slit

Note: It is recommended that the GPLA30RJ000F be used under the condition of typical $I_F=30\text{mA}$ for which it is designed.

3.4 Output waveform

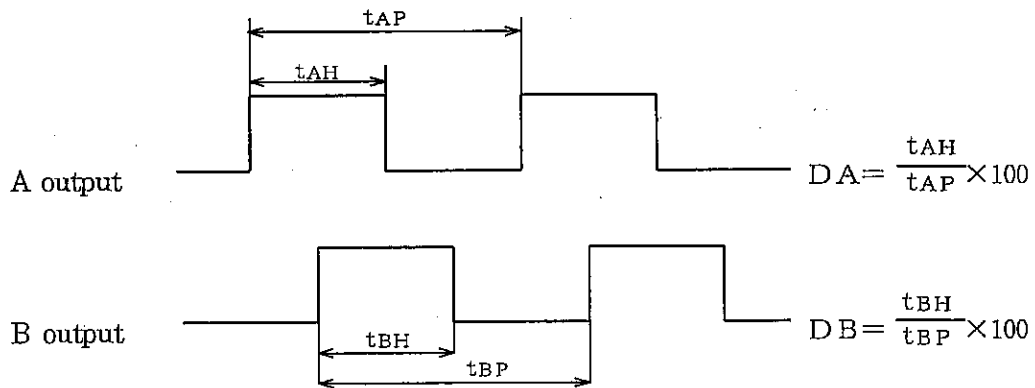

The rotational direction can be distinguished by phase-adjustment of A and B when mounting the encoder.

REFERENCE

Fig.1 Forward current vs. ambient temperature

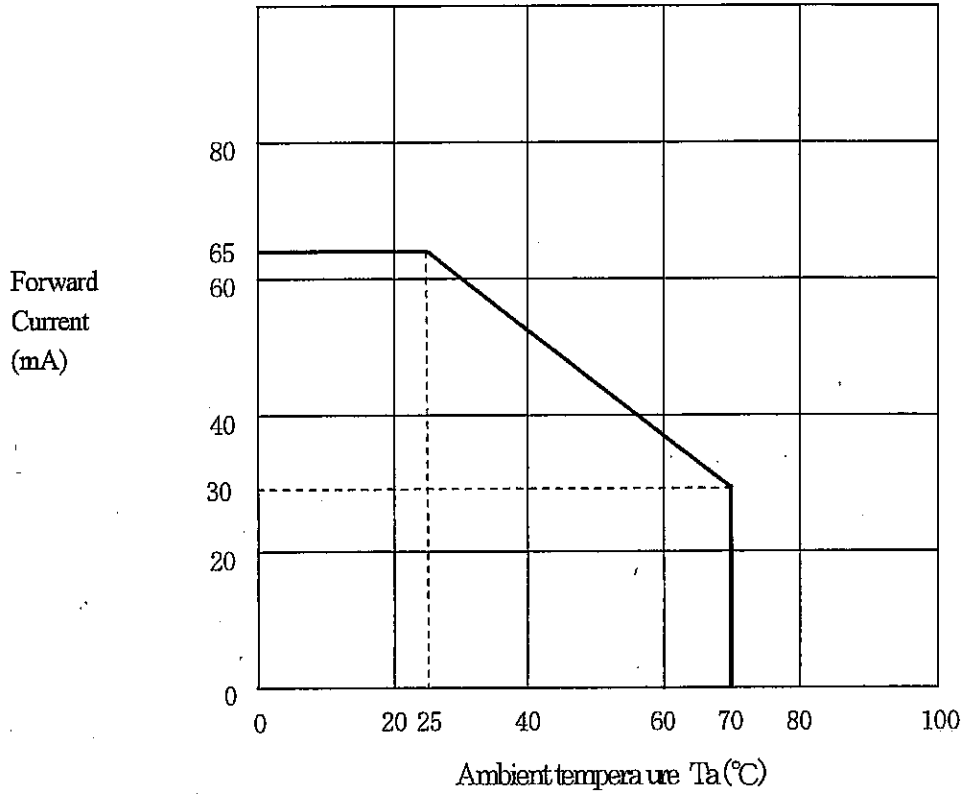
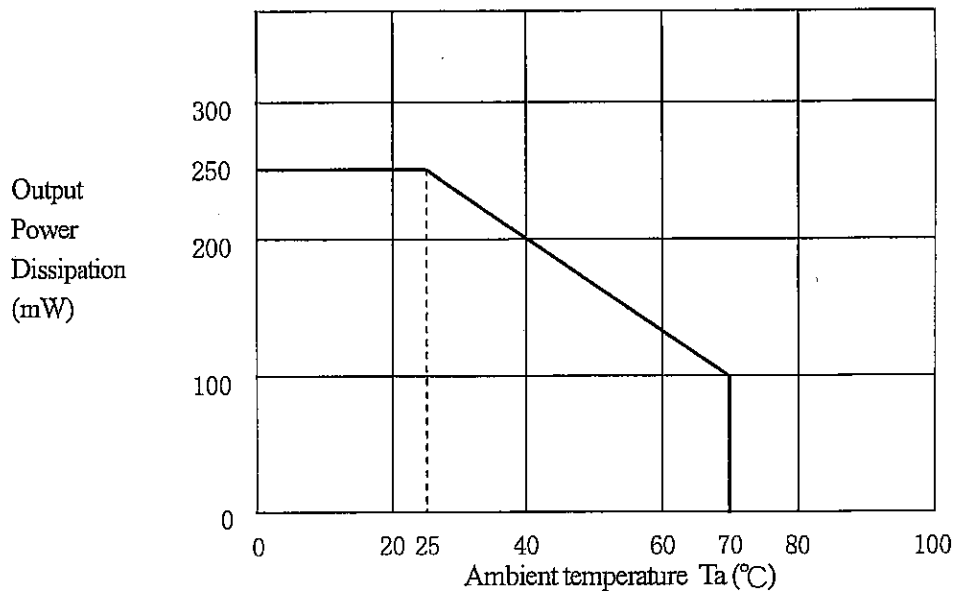

Fig.2 Output power dissipation vs. ambient temperature



REFERENCE

ED-04G026 GP1A30RJ000F

March 24, 2004

Fig3 GP1A30RJ000F Test Condition (Drawing No.CY12003i06)

Scale : Free Unit : mm

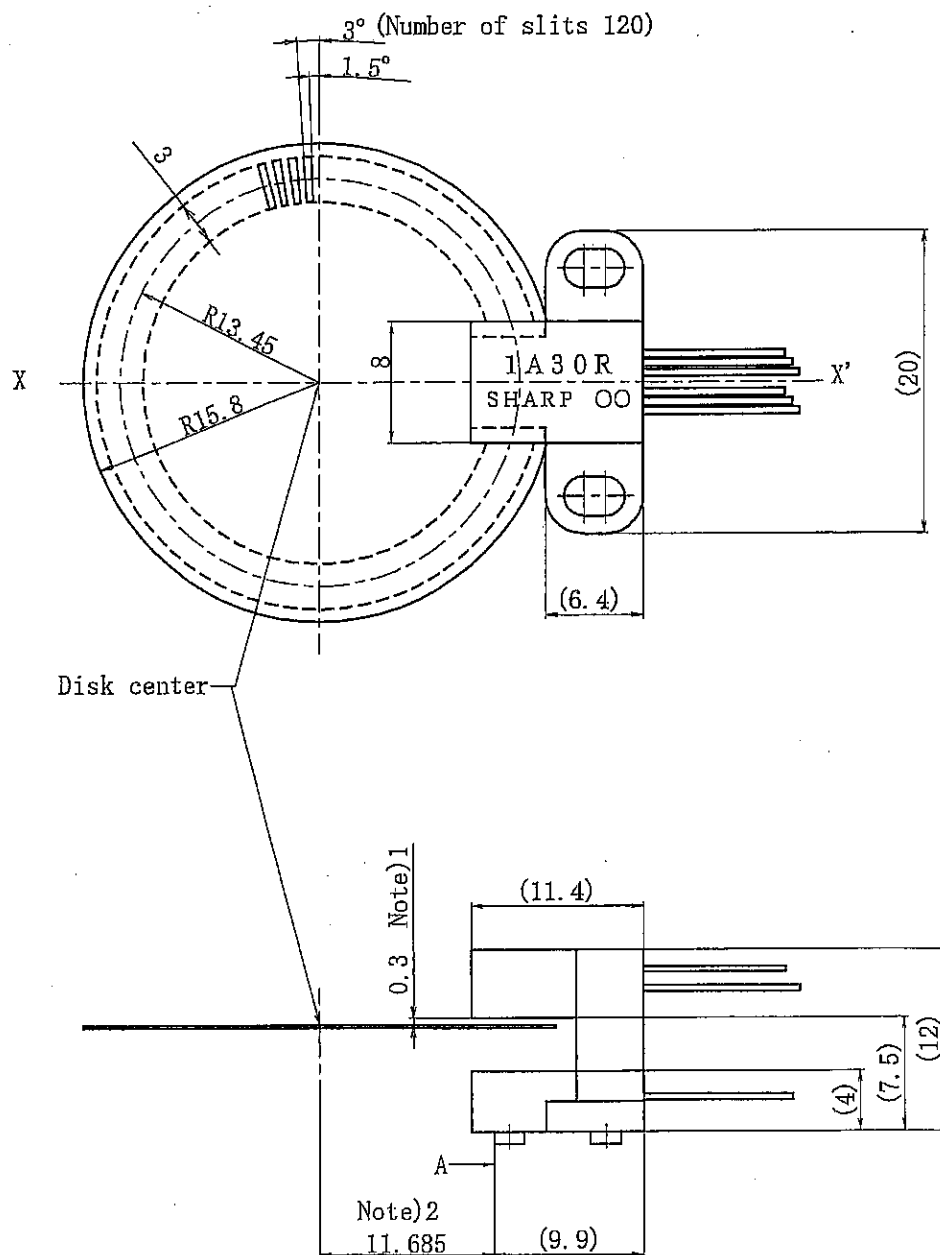

Note

- 1) Distance between disk surface and case surface in the detector side is 0.3mm.
- 2) Encoder positioning pin is positioned on X-X' axis. Distance between center of disk and portion A of positioning pin is 11.685mm.
- 3) Center of disk slit is R13.45mm.

4. Reliability

The reliability of products shall satisfy items listed below.

Confidence level : 90%

LTPD : 10 or 20

Test Items	Test Conditions	Failure Judgement Criteria	Samples (n)
			Defective (c)
Temperature cycling	1 cycle -40°C to +80°C (30min) (30min) 20 cycles test	$V_F \geq U \times 1.2$	n=22, c=0
High temp. and high humidity storage	+60°C, 90%RH, 500h	$I_R \geq U \times 2$	n=22, c=0
High temp. storage	+80°C, 500h	$V_{OL} \geq U \times 1.2$	n=22, c=0
Low temp. storage	-40°C, 500h	$V_{OH} \leq L \times 0.8$	n=22, c=0
Operation life	$I_F=30mA, V_{CC}=5V, T_a=25^\circ C, 500h$		n=22, c=0
Mechanical shock	15km/s ² , 0.5ms 3 times/ $\pm X, \pm Y, \pm Z$ direction	$I_{CC} \geq U \times 1.2$	n=11, c=0
Variable frequency vibration	100 to 2000 to 100Hz/4min 4 times/X, Y, Z direction 200m/s ²	Duty : Shall be within the specification values.	n=11, c=0
Terminal strength (Tension)	Weight: 10N 30s/each terminal		n=11, c=0
Terminal strength (Bending)	Weight: 5N 0° →90° →0° →-90° →0° 1time bending	U: Upper specification limit	n=11, c=0
Soldering heat	260°C, 5s Immerse up to 1.6mm from the side face of package.	L: Lower specification limit	n=11, c=0
Solderability	245±3°C, 5s *2	Judgement only appearance Solder shall adhere at less than 95% area of immersed portion of lead.	n=11, c=0

* 1 Test conditions shall be based upon the specification.

*2 The alloy composition of solder used for lead free should be Sn-3.0Ag-0.5Cu.

Flux used for precleaning should be equivalent to EC-19S(TAMURA KAKEN CORPORATION).

REFERENCE

5. Outgoing inspection

5.1 Inspection items

(1) Electrical characteristic

$V_F, I_R, V_{OL}, V_{OH}, I_{CC}, D_A, D_B$

(2) Appearance

5.2 Sampling method and Inspection level

A single sampling plan, normal inspection level II based on ISO 2859 is applied.

The AQL according to the inspection items are shown below.

Defect	Inspection item	AQL (%)
Major defect	Characteristics defect	0.10
	Outline dimensions to influence electrical characteristics*	
	Unreadable marking	
Minor defect	Appearance defect except the above mentioned.	0.25

* Refer to note 4) in the GP1A30RJ000F Outline Dimensions (Drawing No.CY12002i02)

6. Supplements

6.1 Parts

This product uses the below parts.

6.1.1 Light detector (Q'ty : 1)

(Using a silicon photodiode as light detecting portion, and a bipolar IC as signal processing circuit.)

Type	Maximum sensitivity wavelength (nm)	Sensitivity wavelength (nm)	Response time (μ s)
Photodiode	900	400 to 1200	200

6.1.2 Light emitter (Q'ty : 1)

Type	Material	Maximum light emitting wavelength (nm)
Infrared light emitting diode (Non-coherent)	Ga As	950

6.1.3 Material

Holder	Lead plating
Black polycarbonate resin	Sn-Ag-Cu

6.1.4 Others

This product shall not be proof against radiation flux.

Laser generator is not used.

Looking for pricing, stock, or lifecycle information?

Click below to explore more details on WIN SOURCE:

- [⊖ View GP1A30RJ000F on WIN SOURCE](#)
- [⊖ Sharp Microelectronics Information](#)

Optimize Your Supply Chain with WIN SOURCE Solutions

- ✓ Global Sourcing Solution
- ✓ Obsolete Management
- ✓ Cost Control Management
- ✓ Shortage Management
- ✓ Alternative Solution
- ✓ Excess Inventory Management