



**THE DATASHEET OF
GP1S194HCZ0F**



GP1S194HCZ0F

Gap : 1.7mm, Slit : 0.3mm
Phototransistor Output,
Compact Transmissive
Photointerrupter



■Description

GP1S194HCZ0F is a compact and low-profile, transmissive photointerrupter with photo-transistor output and detects an object between the emitter and the detector.

The compact package has been molded by a unique technology that is a combination of transfer and injection molding.

■Features

1. Transmissive with phototransistor output
2. Compact Gap Width : 1.7mm
3. Slit Width (detector side): 0.3mm
4. Package : 3.6×2.0×2.7mm
5. RoHS directive compliant

■Agency approvals/Compliance

1. Compliant with RoHS directive (2002/95/EC)

■Applications

1. General purpose detection of object presence or motion.
Example : Printer, lens control for camera

Notice The content of data sheet is subject to change without prior notice.

In the absence of confirmation by device specification sheets, SHARP takes no responsibility for any defects that may occur in equipment using any SHARP devices shown in catalogs, data books, etc. Contact SHARP in order to obtain the latest device specification sheets before using any SHARP device.

Sheet No.: OP13028EN

■ Outline

Drawing No.CY12950i02

Scale : 10/1

Unit : mm

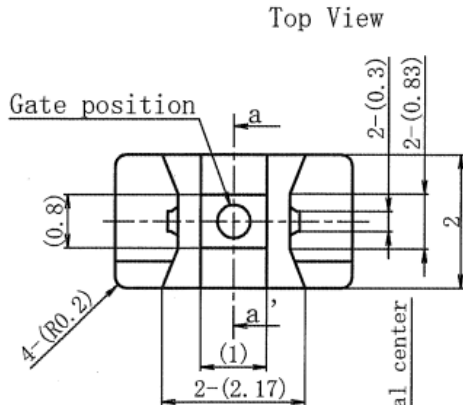

Circuit : Top View

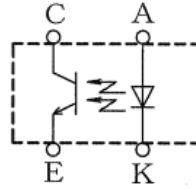

A : Anode
K : Cathode
C : Collector
E : Emitter

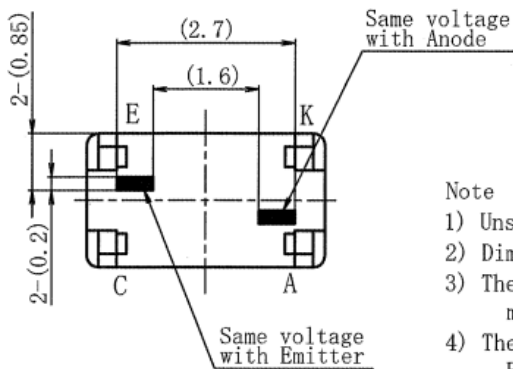
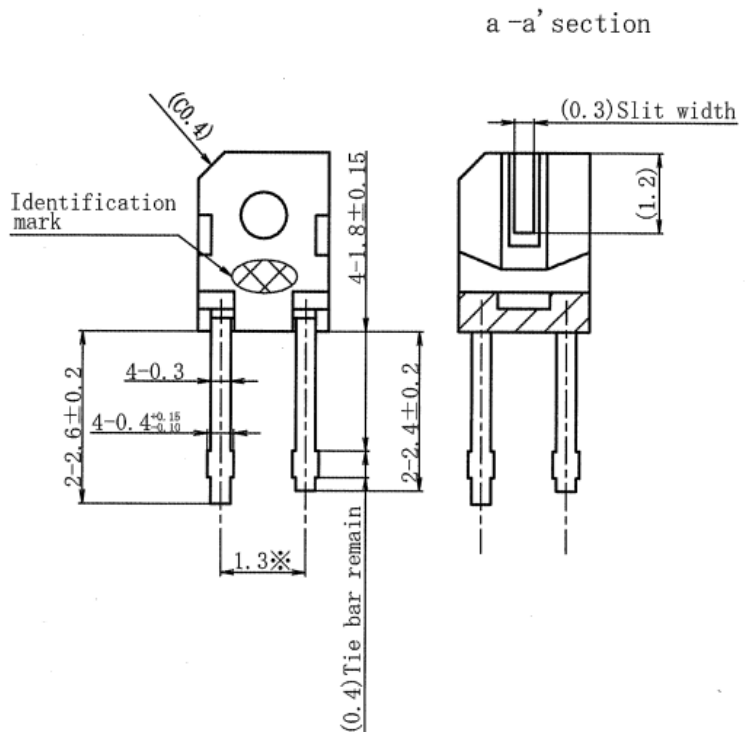
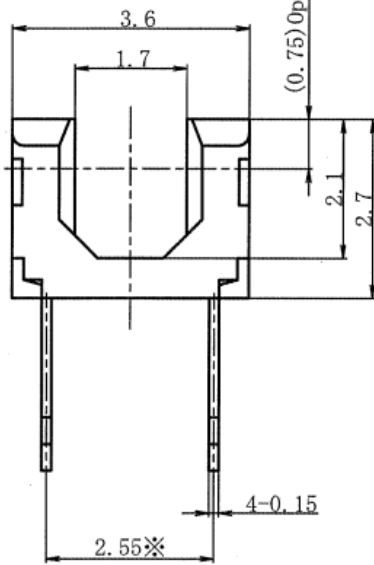

Note

- 1) Unspecified tolerance shall be ± 0.1 mm.
- 2) Dimensions in parenthesis are shown for reference.
- 3) The dimensions indicated by * refer to the those measured from the lead base.
- 4) The dimensions shown do not include those of burrs. Burr's dimensions shall be 0.15Max.
- 5) The lead may be exposed at the shaded portion.
- 6) A green color mark is printed at the emitter side for identifying the direction.
- 7) The edge surface of the tie bar remains has poor solderability due to no plating, so please select a proper PCB thickness to avoid any influences. 1.2mm thickness shall be recommended.

■ **Absolute maximum ratings**

Ta=25°C

Parameter		Symbol	Rating	Unit
Input	Forward current	I _F	30	mA
	Reverse voltage	V _R	6	V
	Power dissipation	P	75	mW
Output	Collector-emitter voltage	V _{CEO}	35	V
	Emitter-collector voltage	V _{ECO}	6	V
	Collector current	I _c	20	mA
	Collector power dissipation	P _c	75	mW
Total power dissipation		P _{tot}	100	mW
Operating temperature		T _{opr}	-25 to +85	°C
Storage temperature		T _{stg}	-40 to +100	°C
* Soldering temperature		T _{sol}	260	°C

* Soldering time : 3 s or less

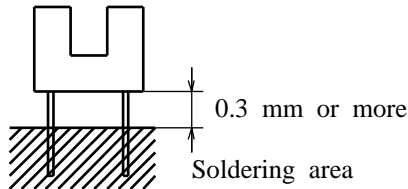

■ **Electro-optical characteristics**

Ta=25°C

Parameter		Symbol	Conditions	MIN.	TYP.	MAX.	Unit	
Input	Forward voltage	V _F	I _F =20mA	-	1.2	1.4	V	
	Reverse current	I _R	V _R =3V	-	-	10	μA	
Output	Collector dark current	I _{CEO}	V _{CE} =20V	-	-	100	nA	
Transfer characteristics	Collector current		I _c	V _{CE} =5V, I _F =5mA	150	-	600	μA
	Response time	(Rise)	t _r	V _{CE} =5V, I _c =100μA R _L =1kΩ	-	50	150	μs
		(Fall)	t _f		-	50	150	μs
	Collector-emitter saturation voltage		V _{CE(sat)}	I _F =10mA, I _c =40μA	-	-	0.4	V

(Test circuit for response time)

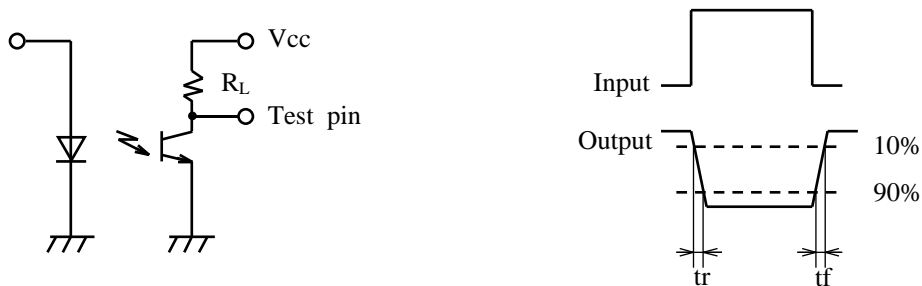

Foward current vs. ambient temperature

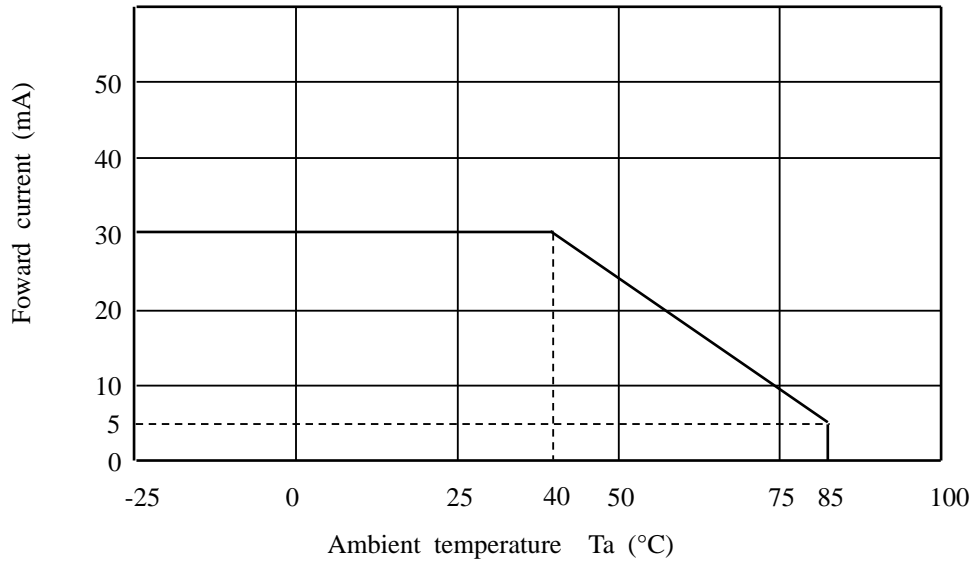

Power dissipation vs. ambient temperature

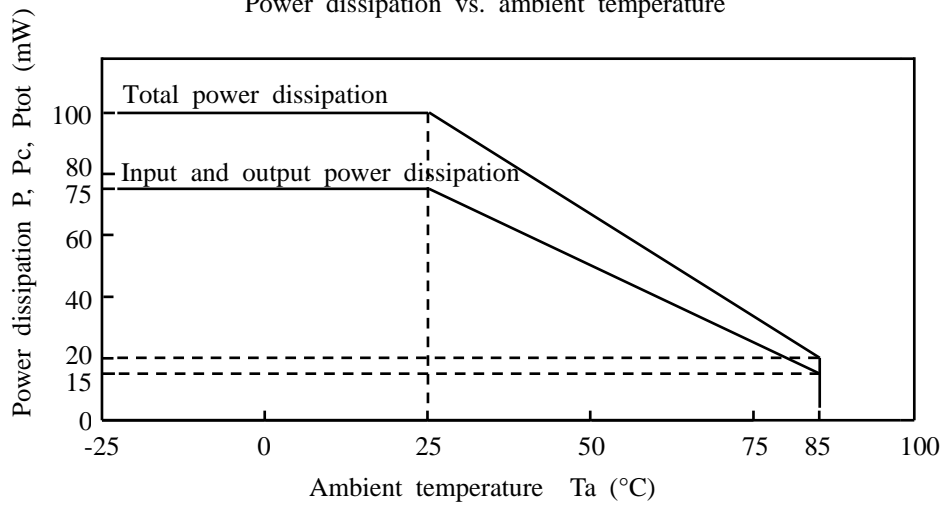

Relative collector current vs. shield distance 1 (Reference value)

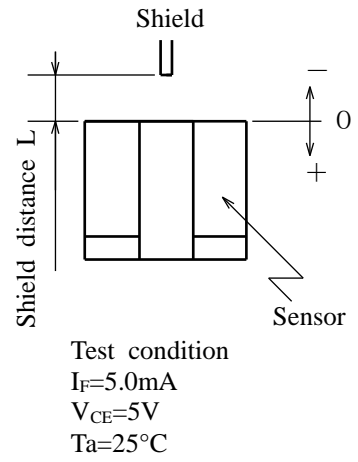
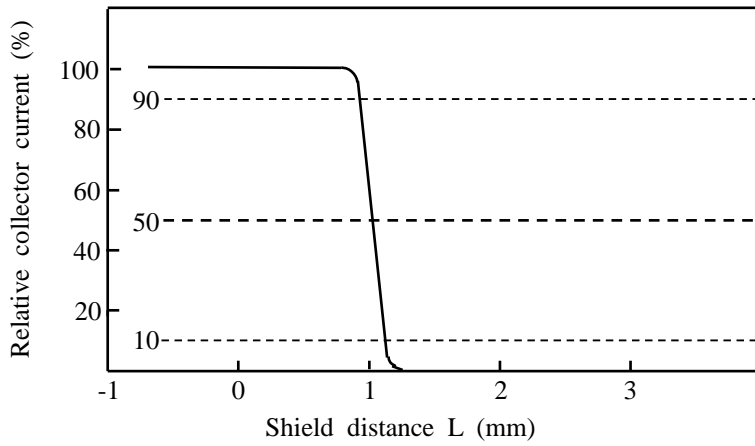

Relative collector current vs. shield distance 2 (Reference value)

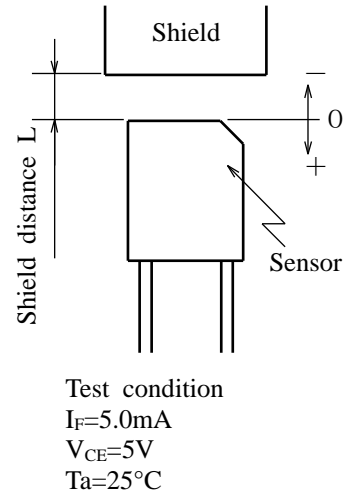
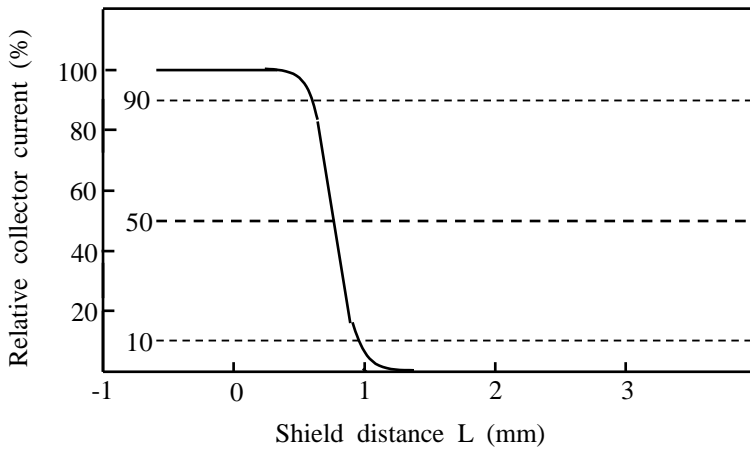

■ **Supplements**

● **Parts**

Refer to the attached sheet, Page 8.

● **Packing**

Refer to the attached drawing No. CY12951i09B, Page 9.

● **ODS materials**

This product shall not contain the following materials.

Also, the following materials shall not be used in the production process for this product.

Materials for ODS : CFCs, Halon, Carbon tetrachloride, 1.1.1-Trichloroethane (Methyl chloroform)

● **Specified brominated flame retardants**

Specified brominated flame retardants (PBB and PBDE) are not used in this device at all.

● **Compliance with each regulation**

1) The RoHS directive(2002/95/EC)

This product complies with the RoHS directive(2002/95/EC)

Object substances: mercury,lead, cadmium,hexavalent chromium,polybrominated biphenyls (PBB)

and polybrominated diphenyl ethers (PBDE)

2) Content of six substances specified in Management Method for Control of Pollution Caused by Electronic

Information Products Regulation (Chinese : 电子信息产品污染控制管理办法).

Category	Toxic and hazardous substances					
	Lead (Pb)	Mercury (Hg)	Cadmium (Cd)	Hexavalent chromium (Cr ⁶⁺)	Polybrominated biphenyls (PBB)	Polybrominated diphenyl ethers (PBDE)
Photointerrupter	✓	✓	✓	✓	✓	✓

✓ : indicates that the content of the toxic and hazardous substance in all the homogeneous materials of the part is below the concentration limit requirement as described in SJ/T 11363-2006 standard.

● **Product mass : Approximately 24mg**

● **Country of origin : Japan and China**

■Notes

●Circuit design

In circuit designing, make allowance for the degradation of the light emitting diode output that results from long continuous operation. (50% degradation/5 years)

●Prevention of detection error

To prevent photointerrupter from faulty operation caused by external light, do not set the detecting face to the external light.

●Position of opaque board

Opaque board shall be installed at place 1.4mm or more from the top of elements.

(Example)

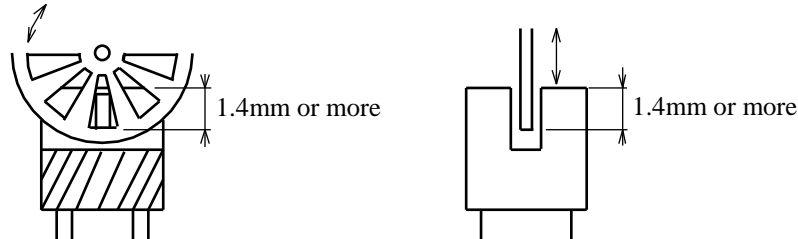

●Soldering

To solder onto lead pins, solder at the position of 0.3mm or more from the package's bottom at 260°C for 3s or less.

Please don't bend lead pins from the root of package when soldering.

Please also take care not to let any external force exert on lead pins.

Please don't do soldering with preheating, and please don't do soldering by reflow.

Please have soldering adjustment, etc. after GP1S194HCZ0F is cooled down, and also note that the outer mold resin may be meltdown by heating for a long time.

●Cleaning

Cleaning shall be carried out under the below conditions to avoid keeping solvent, solder and flux on the device.

- (1) Solvent cleaning : Solvent temperature 45°C or less, Immersion for 3min. or less
- (2) Ultrasonic cleaning : Since the influence to the product may changes by the conditions of the ultrasonic power, time, the tank size, PCB size, the product installation condition, etc., please evaluate with actual conditions and confirm before usage.
- (3) The cleaning shall be carried out with solvent below.

Solvent : Ethyl alcohol, Methyl alcohol

●Lead pin

Lead terminals of this product are tin copper alloy plated. Before usage, please evaluate solder ability with actual conditions and confirm. The uniformity in color for the lead terminals are not specified.

■Parts

This product uses the below parts.

●Light detector (Quantity : 1)

Type	Material	Maximum sensitivity (nm)	Sensitivity (nm)	Response time (μs)
Phototransistor	Silicon (Si)	930	700 to 1200	20

●Light emitter (Quantity : 1)

Type	Material	Maximum light emitting wavelength (nm)	I/O Frequency (MHz)
Infrared light emitting diode (non-coherent)	GaAs	950	0.3

●Material

Case	Lead frame	Lead frame plating
Black PPS resin (UL 94V-0)	42 Alloy	SnCu plating

●Others

This product shall not be proof against radiation flux.

■Packing (Drawing No.:CY12951i09B)

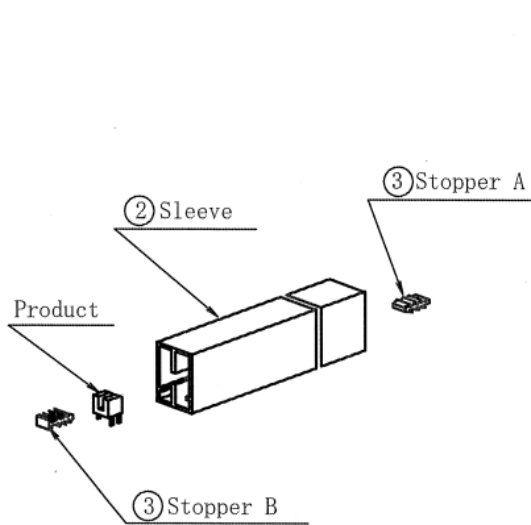

< Fig. 1 >

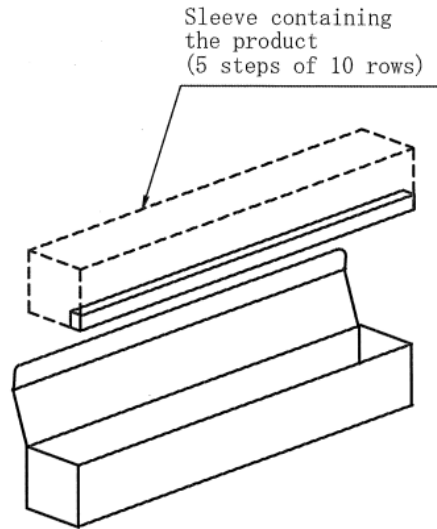

< Fig. 2 >

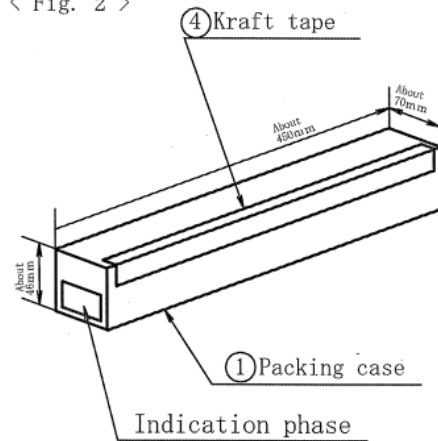

< Fig. 3 >

1. Packing material

No	Name	material	The number of use
1	Packing case	Paper corrugated cardboard	1
2	Sleeve	Polycarbonate	50
3	Stopper A, B	rubber	50, respectively
4	Kraft tape	—	—

2. Packing quantity

1. Packing sleeve : 200pieces per 1 sleeve
2. Packing case : 10000pieces per 1 case
(Gross weight : Approx 850 g)

3. Indication items

The contents of the carton indication conforms to EIAJ C-3 and the following items are indicated.

Model No., Internal production control name, Quantity, Packing date, Corporate name, Country of origin

4. Packing method

1. 200 products are contained to a sleeve.
(The receipt method is shown in the above figure.) <Fig.1>
2. 50 sleeves (5 steps of 10 rows) are contained into a packing case.
<Fig.2>
3. The packing case is sealed off with the kraft tape.
Indicates on the packing case Model No., Internal production control name, Quantity, Packing date, Corporate name, Country of origin. <Fig.3>

■ Important Notices

· The circuit application examples in this publication are provided to explain representative applications of SHARP devices and are not intended to guarantee any circuit design or license any intellectual property rights. SHARP takes no responsibility for any problems related to any intellectual property right of a third party resulting from the use of SHARP's devices.

· Contact SHARP in order to obtain the latest device specification sheets before using any SHARP device. SHARP reserves the right to make changes in the specifications, characteristics, data, materials, structure, and other contents described herein at any time without notice in order to improve design or reliability. Manufacturing locations are also subject to change without notice.

· Observe the following points when using any devices in this publication. SHARP takes no responsibility for damage caused by improper use of the devices which does not meet the conditions and absolute maximum ratings to be used specified in the relevant specification sheet nor meet the following conditions:

(i) The devices in this publication are designed for use in general electronic equipment designs such as:

- Personal computers
- Office automation equipment
- Telecommunication equipment [terminal]
- Test and measurement equipment
- Industrial control
- Audio visual equipment
- Consumer electronics

(ii) Measures such as fail-safe function and redundant design should be taken to ensure reliability and safety when SHARP devices are used for or in connection

with equipment that requires higher reliability such as:

- Transportation control and safety equipment (i.e., aircraft, trains, automobiles, etc.)
- Traffic signals
- Gas leakage sensor breakers
- Alarm equipment
- Various safety devices, etc.

(iii) SHARP devices shall not be used for or in connection with equipment that requires an extremely high level of reliability and safety such as:

- Space applications
- Telecommunication equipment [trunk lines]
- Nuclear power control equipment
- Medical and other life support equipment (e.g., scuba).

· If the SHARP devices listed in this publication fall within the scope of strategic products described in the Foreign Exchange and Foreign Trade Law of Japan, it is necessary to obtain approval to export such SHARP devices.

· This publication is the proprietary product of SHARP and is copyrighted, with all rights reserved. Under the copyright laws, no part of this publication may be reproduced or transmitted in any form or by any means, electronic or mechanical, for any purpose, in whole or in part, without the express written permission of SHARP. Express written permission is also required before any use of this publication may be made by a third party.

· Contact and consult with a SHARP representative if there are any questions about the contents of this publication.

Looking for pricing, stock, or lifecycle information?

Click below to explore more details on WIN SOURCE:

- ⊖ [View GP1S194HCZ0F on WIN SOURCE](#)
- ⊖ [Sharp Microelectronics Information](#)

Optimize Your Supply Chain with WIN SOURCE Solutions

- ✓ Global Sourcing Solution
- ✓ Obsolete Management
- ✓ Cost Control Management
- ✓ Shortage Management
- ✓ Alternative Solution
- ✓ Excess Inventory Management