



**THE DATASHEET OF
GP1S525V**



SHARP

OPTO-ELECTRONIC DEVICES DIVISION
ELECTRONIC COMPONENTS GROUP
SHARP CORPORATION

SPECIFICATION

DEVICE SPECIFICATION FOR

PHOTOINTERRUPTER

MODEL No.

GP1S525V

Specified for

Enclosed please find copies of the Specifications which consists of 14 pages including cover.

After confirmation of the contents, please be sure to send back copies of the Specifications with approving signature on each.

CUSTOMER'S APPROVAL

DATE

BY

PRESENTED

DATE

Apr. 26, 2001

BY

O. Ichikawa

O. Ichikawa,
Department General Manager of
Engineering Dept., III
Opto-Electronic Devices Div.
ELECOM Group
SHARP CORPORATION

Product name : PHOTOINTERRUPTER

Model No. : GP1S525V

1. These specification sheets include materials protected under copyright of Sharp Corporation ("Sharp"). Please do not reproduce or cause anyone to reproduce them without Sharp's consent.
2. When using this product, please observe the absolute maximum ratings and the instructions for use outlined in these specification sheets, as well as the precautions mentioned below. Sharp assumes no responsibility for any damage resulting from use of the product which does not comply with the absolute maximum ratings and the instructions included in these specification sheets, and the precautions mentioned below.

(Precautions)

- (1) This product is designed for use in the following application areas :

[• OA equipment • Audio visual equipment • Home appliances
• Telecommunication equipment (Terminal) • Measuring equipment
• Tooling machines • Computers]

If the use of the product in the above application areas is for equipment listed in paragraphs (2) or (3), please be sure to observe the precautions given in those respective paragraphs.

- (2) Appropriate measures, such as fail-safe design and redundant design considering the safety design of the overall system and equipment, should be taken to ensure reliability and safety when this product is used for equipment which demands high reliability and safety in function and precision, such as :

[• Transportation control and safety equipment (aircraft, train, automobile etc.)
• Traffic signals • Gas leakage sensor breakers • Rescue and security equipment
• Other safety equipment]

- (3) Please do not use this product for equipment which require extremely high reliability and safety in function and precision, such as :

[• Space equipment • Telecommunication equipment (for trunk lines)
• Nuclear power control equipment • Medical equipment]

- (4) Please contact and consult with a Sharp sales representative if there are any questions regarding interpretation of the above three paragraphs.

3. Please contact and consult with a Sharp sales representative for any questions about this product.

1. Application

This specification applies to the outline and characteristics of transmissive type photointerrupter, Model No. GP1S525V.

2. Outline

2.1 Refer to the attached drawing No. CY10767102.

2.2 Production date marking : Refer to the attached sheet, Page 5.

3. Ratings and characteristics

Refer to the attached sheet, Page 6 to 8.

4. Reliability

Refer to the attached sheet, Page 9.

5. Outgoing inspection

Refer to the attached sheet, Page 10.

6. Supplements**6.1 Parts**

Refer to the attached sheet, Page 11.

6.2 ODS materials

This product shall not contain the following materials.
Also, the following materials shall not be used in the production process for this product.

Materials for ODS : CFC_s, Halon, Carbon tetrachloride,
1.1.1-Trichloroethane (Methylchloroform)

6.3 Brominated flame retardants

Specific brominated flame retardants such as the PBBO_s and PBB_s are not used in this device at all.

6.4 Product mass : Approx. 0.55g**6.5 Sleeve**

Refer to the attached drawing No. CY10768109.

6.6 Package

Refer to the attached drawing No. SOE001163.

7. Notes

- 1) In circuit designing, make allowance for the degradation of the light emitting diode output that results from long continuous operation.
(50% degradation/5 years)
- 2) Opaque board shall be installed at place 4mm or more from the top of elements.

(Example)

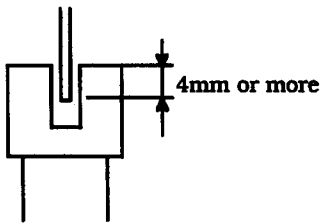

- 3) To solder onto lead pins, solder at 260°C for 5 s or less.
Please take care not to let any external force exert on lead pins when soldering or just after soldering. Please don't do soldering with preheating, and please don't do soldering by reflow.
- 4) Cleaning conditions :
 - (1) Solvent cleaning : Solvent temperature 45°C or less
Immersion for 3 min or less
 - (2) Ultrasonic cleaning : The effect to device by ultrasonic cleaning differs by cleaning bath size, ultrasonic power output, cleaning time, PCB size or device mounting condition etc. Please test it in actual using condition and confirm that doesn't occur any defect before starting the ultrasonic cleaning.
- (3) The cleaning shall be carried out with solvent below.

Solvent : Ethyl alcohol, Methyl alcohol, Isopropyl alcohol
- 5) Some flux, which is used in soldering, may crack the package due to synergistic effect of alcohol in flux and the rise in temperature by heat in soldering.
Therefore, in using flux, please make sure that it does not have any influence on appearance and reliability of the photointerrupter.

2. Outline (Drawing No. CY10767102)

Scale : 2/1

Unit : mm

1) Unspecified tolerances shall be followed the list below.

6) A part of the holder projects over the side. (*3)

Dimension	Tolerance(±)
$d \leq 6$	0.1
$6 < d \leq 18$	0.2

7) Tolerance specification is measured at time of insertion into plastic tubes as per drawing on Page 12/13 of this specification. (*4)

2) Dimensions in parenthesis are shown for reference.

3) Dimensions of lead top shall exclude burr

4) "2.65mm" shows measurement to the nominal center of the lead. (*1)

5) "10.3m" & "2.54mm" part shows the ideal measurement, from the nominal center of the holder. (*2)

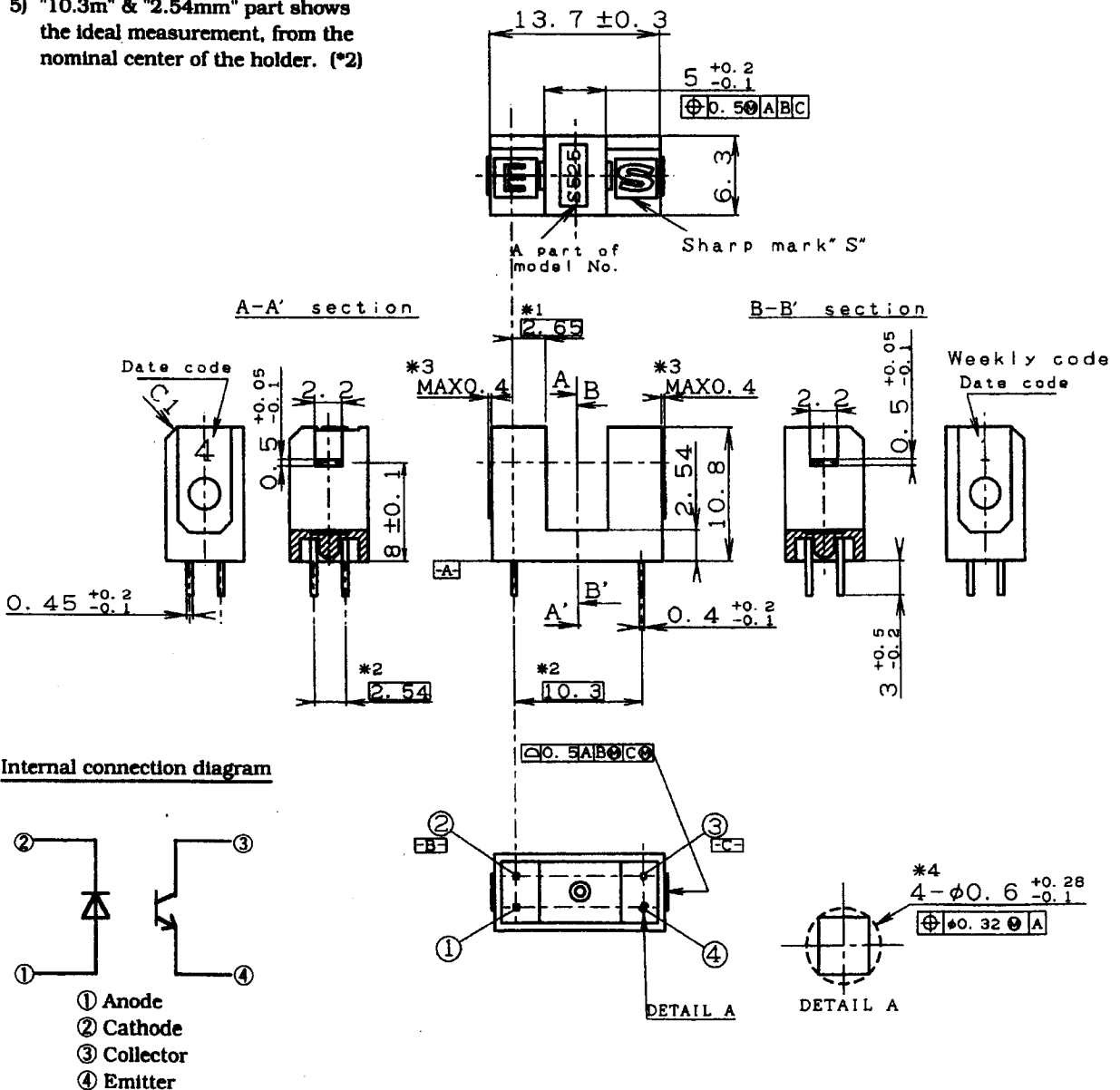

2.2 Production date marking

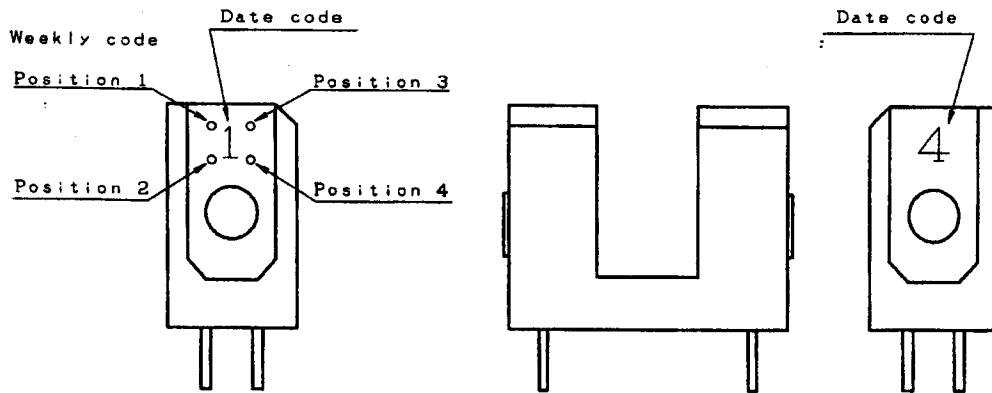

Production day is indicated on holder side face by dot mark as following table.

Production day *	Dot mark position
1st to 8th	Position 1
9th to 16th	Position 2
17th to 24th	Position 3
25th to 31th	Position 4

* Production day means the date that the device passes Sharp inspection after production.

3. Ratings and characteristics

3.1 Absolute maximum ratings

Ta=25°C

Parameter		Symbol	Rating	Unit
Input	*1 Forward current	I_F	50	mA
	*1,2 Peak forward current	I_{FM}	1	A
	Reverse voltage	V_R	6	V
	Power dissipation	P	75	mW
Output	Collector-emitter voltage	V_{CEO}	35	V
	Emitter-collector voltage	V_{ECO}	6	V
	Collector current	I_c	20	mA
	*1 Collector power dissipation	P_c	75	mW
Operating temperature		T_{opr}	-25 to +85	°C
Storage temperature		T_{stg}	-40 to +85	°C
*3 Soldering temperature		T_{sol}	260	°C

*1 The derating factors of absolute maximum ratings due to ambient temperature are shown in Fig. 1, 2, 3.

*2 Pulse width $\leq 100 \mu s$, Duty ratio : 0.01

*3 For 5 s

3.2 Electro-optical characteristics

Ta=25°C

Parameter		Symbol	Conditions	MIN.	TYP.	MAX.	Unit
Input	Forward voltage	V_F	$I_F=20\text{mA}$	-	1.25	1.4	V
	Peak forward voltage	V_{FM}	$I_{FM}=0.5\text{A}$	-	3	4	V
	Reverse current	I_R	$V_R=3\text{V}$	-	-	10	μA
Output	Dark current	I_{CEO}	$V_{CE}=10\text{V}, I_F=0\text{mA}$	-	1	100	nA
Transfer characteristics	Collector current	I_C	$V_{CE}=10\text{V}, I_F=20\text{mA}, R=0\Omega$	0.65	-	15.0	mA
	Collector-emitter saturation voltage	$V_{CE}(\text{sat})$	$I_F=20\text{mA}, I_C=0.4\text{mA}$	-	-	0.4	V
	Response time	(Rise)	t_{on}	$V_{CE}=7\text{V}, I_C=2\text{mA}, R_L=1\text{k}\Omega$	-	15	-
(Fall)		t_{off}	-		15	-	μs

(Test circuit for response time)

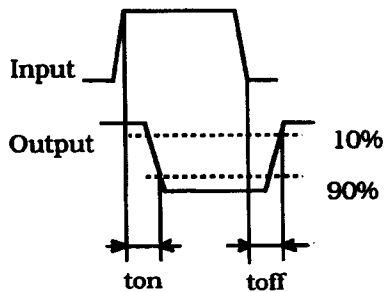
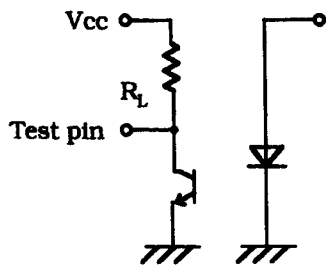

Fig.1 Forward current vs. ambient temperature

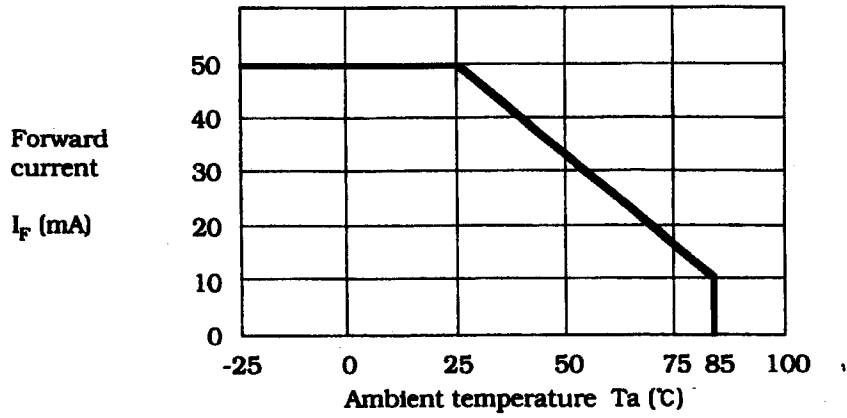

Fig.2 Collector power dissipation vs. ambient temperature

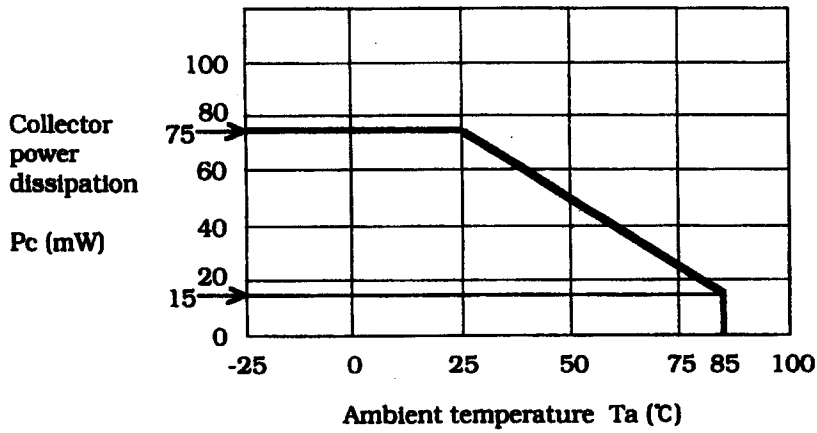
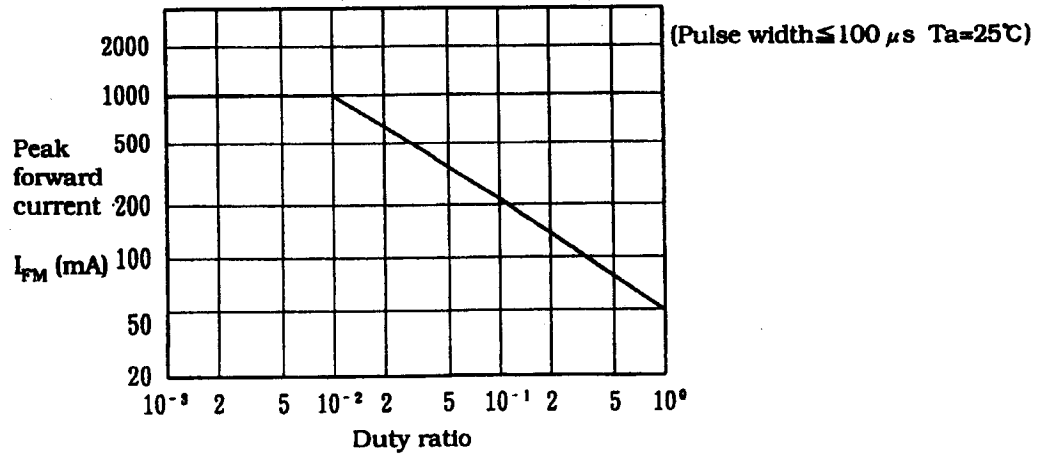

Fig.3 Peak forward current vs. duty ratio



4. Reliability

The reliability of products shall satisfy items listed below.

Confidence level : 90%
LTPD : 10%/20%

Test Items	Test Conditions	Failure Judgement Criteria	Samples (n) Defective (c)
Temperature cycling	1 cycle -40°C to +85°C (30min) (30min) 20 cycles test	$V_F \geq U \times 1.2$ $I_R \geq U \times 2$ $I_C \leq L \times 0.8$ $I_{CEO} \geq U \times 2$ U: Upper specification limit L: Lower specification limit	n=22, c=0
High temp. and high humidity storage	+60°C, 90%RH, 500h		n=22, c=0
High temp. storage	+85°C, 500h		n=22, c=0
Low temp. storage	-40°C, 500h		n=22, c=0
Operation life	$I_F=20mA$, $T_a=25^\circ C$, 500h		n=22, c=0
Mechanical shock	15km/s ² , 0.5ms 3 times/ $\pm X$, $\pm Y$, $\pm Z$ direction		n=11, c=0
Variable frequency vibration	100 to 2000 to 100Hz/20min 2h/ X , Y , Z direction 100m/s ²		n=11, c=0
Terminal strength (Tension)	Weight: 10N 30s/each terminal		n=11, c=0
Terminal strength (Bending)	Weight: 5N 0° → 90° → 0° → -90° → 0° 1 time bending		n=11, c=0
Soldering heat	260°C, 5s		n=11, c=0
Solderability	230°C, 5s	*1	n=11, c=0

*1 Solder shall adhere at less than 95% area of immersed portion of lead.

* Terminal bending direction is shown below.

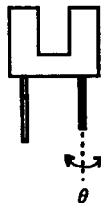

5. Outgoing inspection

5.1 Inspection items

(1) Electrical characteristics

$V_F, V_{FM}, I_R, BV_{ECO}, BV_{CEO}, I_c, I_{CEO}, V_{CE(sat)}$

(2) Appearance

5.2 Sampling method and Inspection level

A single sampling plan, normal inspection level II based on ISO 2859 is applied. The AQL according to the inspection items are shown below.

Defect	Inspection item	AQL (%)
Major defect	Characteristics defect Unreadable marking	0.065
Minor defect	Appearance defect except the above mentioned.	0.25

6. Supplements

6.1 Parts

This product uses the below parts.

6.1.1 Light detector (PT480, Q'ty : 1)

Type	Material	Maximum sensitivity wavelength (nm)	Sensitivity wavelength (nm)	Response time (μs)
Phototransistor	Silicon (Si)	800	400 to 1200	3

6.1.2 Light emitter (GL480, Q'ty : 1)

Type	Material	Maximum light emitting wavelength (nm)	I/O Frequency (MHz)
Infrared light emitting diode (non-coherent)	GaAs	950	0.3

6.1.3 Material

Case	Lead flame finish
Black polycarbonate resin	Solder plating or solder dip

6.1.4 Others

This product shall not be proof against radiation flux.

6.2 Sleeve (Drawing No. : CY10768109)

SCALE : FREE

UNIT : 1/1mm

- 1) Unspecified tolerances shall be $\pm 0.3\text{mm}$.
- 2) Dimensions in parenthesis are shown for reference.

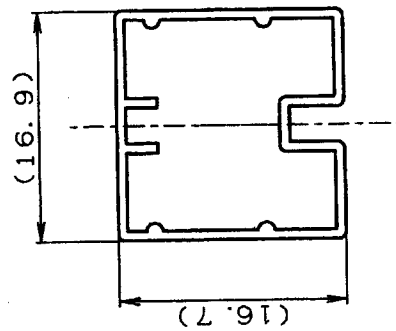
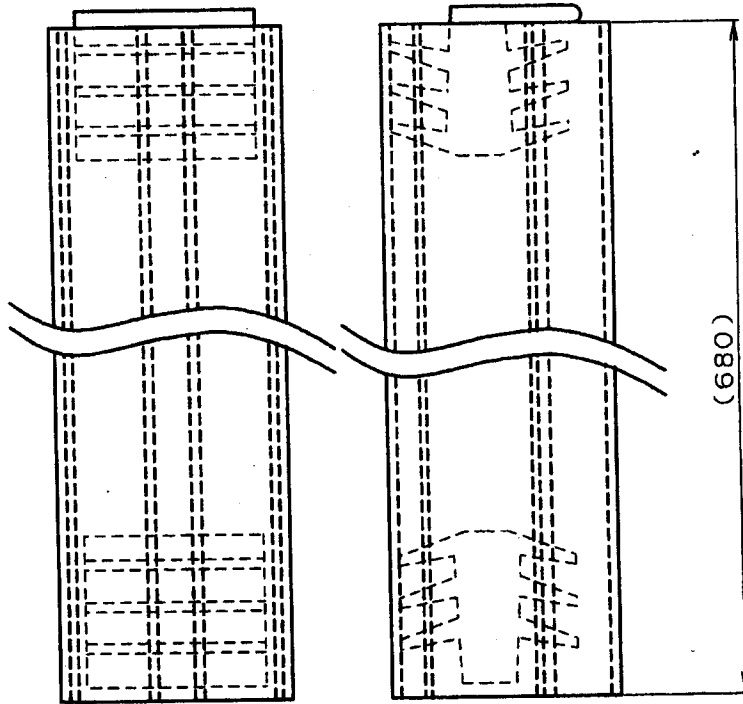

Packaging (Drawing No. SOE001163)

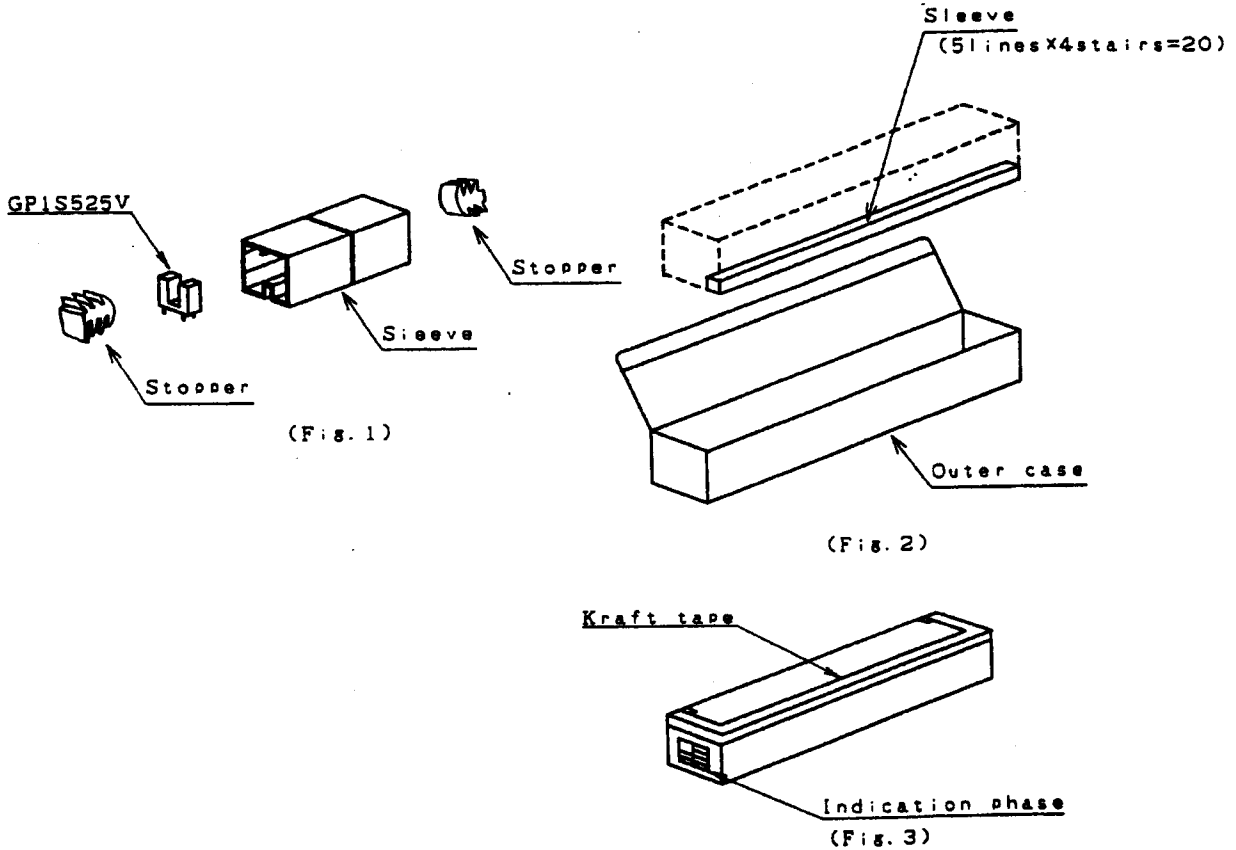

1) Package materials

Outer package : Packing case (Paper corrugated cardboard)
 Inner package : Sleeve (Polystyren)
 Stopper (PS-Elastomer)

2) Package method

1. MAX. 100 pcs. of products shall be packaged in a sleeve. (Fig.1)
2. MAX. 20 sleeves (5 lines X 4 stairs) above shall be packaged in a outer case. (Fig.2)
3. Fix the packing case by craft tape, and fill in the blanks of Model No., Quantity and Inspection Date. (Fig.3)

(2000 pcs./a packing box)

Looking for pricing, stock, or lifecycle information?

Click below to explore more details on WIN SOURCE:

- ⊖ [View GP1S525V on WIN SOURCE](#)
- ⊖ [Sharp Microelectronics Information](#)

Optimize Your Supply Chain with WIN SOURCE Solutions

- ✓ Global Sourcing Solution
- ✓ Obsolete Management
- ✓ Cost Control Management
- ✓ Shortage Management
- ✓ Alternative Solution
- ✓ Excess Inventory Management