



**THE DATASHEET OF  
GTLP1B151K8X**



## GTLP1B151

### 1-Bit LVTTTL/GTLP Transceiver with Separate LVTTTL Port and Feedback Path

#### General Description

The GTLP1B151 is a 1-bit transceiver that provides LVTTTL-to-GTLP signal level translation. Individual LVTTTL and GTLP driver enables are also available. The GTLP1B151 offers separate LVTTTL inputs and outputs, and can provide a feedback path for control and diagnostics monitoring.

High-speed backplane operation is a direct result of GTLP's reduced output swing (<1V), reduced input threshold levels and output edge rate control. The edge rate control minimizes bus-settling time. GTLP is a Fairchild Semiconductor derivative of the Gunning Transistor Logic (GTL) JEDEC standard JESD8-3.

Fairchild's GTLP has internal edge-rate control and is process, voltage and temperature compensated. GTLP's I/O structure is similar to GTL and BTL but offers different output levels and receiver threshold. Typical GTLP output voltage levels are:  $V_{OL} = 0.5V$ ,  $V_{OH} = 1.5V$ , and  $V_{REF} = 1V$ .

#### Features

- Separate LVTTTL inputs and outputs
- A feedback path for control and diagnostics monitoring
- Bidirectional interface between GTLP and LVTTTL logic levels
- Designed with edge rate control circuitry to reduce output noise on the GTLP port
- $V_{REF}$  pin provides external supply reference voltage for receiver threshold adjustability
- Special PVT compensation circuitry to provide consistent performance over variations of process, supply voltage and temperature
- TTL compatible driver and control inputs
- Designed using Fairchild advanced BiCMOS technology
- Bushold data inputs on A port to eliminate the need for external pull-up resistors for unused inputs
- Power up/down and power off high impedance for live insertion
- Open drain on GTLP to support wired-or connection
- Flow through pinout optimizes PCB layout
- A Port source/sink -24mA / +24mA
- B Port sink +50mA

#### Ordering Code:

Order Number	Package Number	Package Description
GTLP1B151M	M08A	8-Lead Small Outline Integrated Circuit (SOIC), JEDEC MS-012, 0.150" Narrow [TUBE]
GTLP1B151MX	M08A	8-Lead Small Outline Integrated Circuit (SOIC), JEDEC MS-012, 0.150" Narrow [TAPE and REEL]
GTLP1B151K8X	MAB08A (Preliminary)	8-Lead US8, JEDEC MO-187, Variation CA 3.1mm Wide [TAPE and REEL]

### Pin Descriptions

Pin Names	Description
OEB, $\overline{\text{OEC}}$	LVTTL Individual Output Enable Controls (OEC is Active LOW)
$V_{CC}$ , GND, $V_{REF}$	Device Supplies
A	A Port LVTTL Input
B	B Port GTLP Input/Output
C	C Port LVTTL Output

### Connection Diagrams

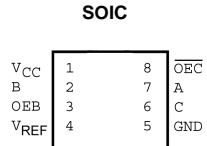
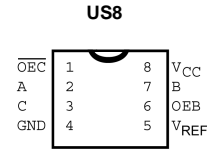

### Functional Description

The GTLP1B151 is a 1-bit transceiver that supports GTLP and LVTTL signal levels. Data polarity is non-inverting with separate LVTTL inputs and outputs and there are individual GTLP and LVTTL output enable controls.

### Functional Tables

Inputs				Outputs		Description
OEB	$\overline{\text{OEC}}$	$A_n$	$B_n$	$B_n$	$C_n$	
H	L	L	Output	L	L	B Bus Enabled, C Bus Enabled
H	L	H	Output	H	H	B Bus Enabled, C Bus Enabled
H	H	L	Output	L	Z	B Bus Enabled, C Bus Disabled
H	H	H	Output	H	Z	B Bus Enabled, C Bus Disabled
L	H	L	L	Z	Z	B Bus Disabled, C Bus Disabled
L	H	H	H	Z	Z	B Bus Disabled, C Bus Disabled
L	L	N/A	L	Z	L	B Bus Disabled, C Bus Enabled
L	L	N/A	H	Z	H	B Bus Disabled, C Bus Enabled

### Logic Diagram

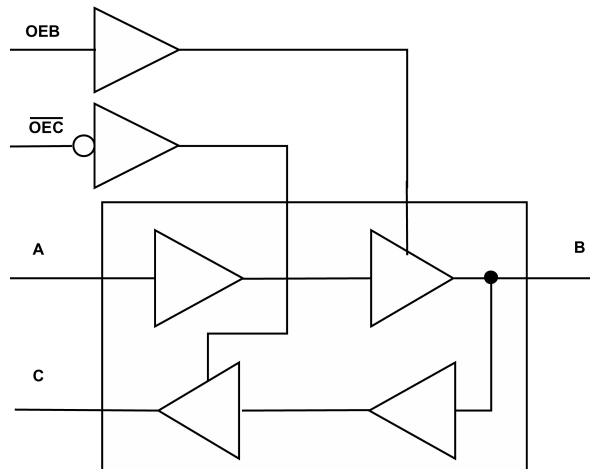

### Absolute Maximum Ratings (Note 1)

Supply Voltage ( $V_{CC}$ )	-0.5V to +4.6V
DC Input Voltage ( $V_I$ )	-0.5V to +4.6V
DC Output Voltage ( $V_O$ )	
Outputs 3-STATE	-0.5V to +4.6V
Outputs Active (Note 2)	-0.5V to +4.6V
DC Output Sink Current into C Port $I_{OL}$	48 mA
DC Output Source Current from C Port $I_{OH}$	-48 mA
DC Output Sink Current into B Port in the LOW State, $I_{OL}$	100 mA
DC Input Diode Current ( $I_{IK}$ ) $V_I < 0V$	-50 mA
DC Output Diode Current ( $I_{OK}$ ) $V_O < 0V$	-50 mA
ESD Rating	>2000V
Storage Temperature ( $T_{STG}$ )	-65°C to +150°C

### Recommended Operating Conditions

Supply Voltage $V_{CC}$	3.15V to 3.45V
Bus Termination Voltage ( $V_{TT}$ )	
GTLP	1.47V to 1.53V
$V_{REF}$	0.98V to 1.02V
Input Voltage ( $V_I$ ) on A Port and Control Pins	0.0V to $V_{CC}$
HIGH Level Output Current ( $I_{OH}$ ) C Port	-24 mA
LOW Level Output Current ( $I_{OL}$ ) C Port	+24 mA
B Port	+50 mA
Operating Temperature ( $T_A$ )	-40°C to +85°C

**Note 1:** Absolute Maximum Ratings are those values beyond which the safety of the device cannot be guaranteed. The device should not be operated at these limits. The parametric values defined in the "Electrical Characteristics" table are not guaranteed at the absolute maximum rating. The "Recommended Operating Conditions" table will define the conditions for actual device operation.

**Note 2:**  $I_O$  Absolute Maximum Rating must be observed.

### DC Electrical Characteristics

Over Recommended Operating Free-Air Temperature Range,  $V_{REF} = 1.0V$  (unless otherwise noted).

Symbol		Test Conditions		Min	Typ (Note 3)	Max	Units
$V_{IH}$	B Port			$V_{REF} + 0.05$		$V_{TT}$	V
	Others			2.0			
$V_{IL}$	B Port			0.0		$V_{REF} - 0.05$	V
	Others					0.8	
$V_{REF}$	B Port			0.7V	1.0	1.3V	V
$V_{TT}$	B Port			$V_{REF} + 50\text{ mV}$	1.5	$V_{CC}$	V
$V_{IK}$		$V_{CC} = 3.15V$	$I_I = -18\text{ mA}$			-1.2	V
$V_{OH}$	C Port	$V_{CC} = \text{Min to Max (Note 4)}$	$I_{OH} = -100\text{ }\mu\text{A}$	$V_{CC} - 0.2$			V
		$V_{CC} = 3.15V$	$I_{OH} = -8\text{ mA}$	2.4			
		$V_{CC} = 3.15V$	$I_{OH} = -24\text{ mA}$	2.2			
$V_{OL}$	C Port	$V_{CC} = \text{Min to Max (Note 4)}$	$I_{OL} = 100\text{ }\mu\text{A}$			0.2	V
		$V_{CC} = 3.15V$	$I_{OL} = 8\text{ mA}$			0.4	
		$V_{CC} = 3.15V$	$I_{OL} = 24\text{ mA}$			0.5	
	B Port	$V_{CC} = 3.15V$	$I_{OL} = 40\text{ mA}$			0.4	
		$V_{CC} = 3.15V$	$I_{OL} = 50\text{ mA}$			0.55	
$I_I$	Control Pins	$V_{CC} = 3.45V$	$V_I = 3.45V$ $V_I = 0V$			5 -5	$\mu\text{A}$
	A Port	$V_{CC} = 3.45V$	$V_I = 3.45V$ $V_I = 0V$			10 -10	
	B Port	$V_{CC} = 3.45V$	$V_I = 3.45V$ $V_I = 0V$			5 -5	
$I_{OFF}$	A or C Ports, Control Pins	$V_{CC} = 0$	$V_I$ or $V_O = 0$ to 3.45V			30	$\mu\text{A}$
	B Port	$V_{CC} = 0$	$V_I$ or $V_O = 0$ to 3.45V			30	
$I_I(\text{HOLD})$	A Port	$V_{CC} = 3.15V$	$V_I = 0.8V$ $V_I = 2.0V$	75		-75	$\mu\text{A}$
$I_{OZH}$	C Port	$V_{CC} = 3.45V$	$V_O = 3.45V$			10	$\mu\text{A}$
	B Port	$V_{CC} = 3.45V$	$V_O = 3.45V$			5	
$I_{OZL}$	C Port	$V_{CC} = 3.45V$	$V_O = 0V$			-10	$\mu\text{A}$
	B Port	$V_{CC} = 3.45V$	$V_O = 0.0V$			-5	

## DC Electrical Characteristics (Continued)

Symbol	Test Conditions	Min	Typ (Note 3)	Max	Units
$I_{PU/PD}$	All Ports $V_{CC} = 0$ to 1.5V	$V_I = 0$ to 3.45V		30	$\mu A$
$I_{CC}$	A or B Ports or C Port $I_O = 0$ $V_I = V_{CC}/V_{TT}$ or GND	Outputs HIGH		11	mA
		Outputs LOW		11	
		Outputs Disabled		11	
$\Delta I_{CC}$ (Note 5)	A Port and Control Pins A or Control Inputs at $V_{CC}$ or GND	One Input at $V_{CC}$ -0.6V		2	mA
$C_i$	Control Pins and A Port	$V_I = V_{CC}$ or 0		3	pF
$C_O$	C Port	$V_I = V_{CC}$ or 0		5	pF
$C_{I/O}$	B Port	$V_I = V_{TT}$ or 0		5.5	pF

**Note 3:** All typical values are at  $V_{CC} = 3.3V$  and  $T_A = 25^\circ C$ .

**Note 4:** For conditions shown as Min, use the appropriate value specified under recommended operating conditions.

**Note 5:** This is the increase in supply current for each input that is at the specified TTL voltage level rather than  $V_{CC}$  or GND.

**Note:** GTLP  $V_{REF}$  and  $V_{TT}$  are specified to 2% tolerance since signal integrity and noise margin can be significantly degraded if these supplies are noisy. In addition,  $V_{TT}$  and  $R_{TERM}$  can be adjusted beyond the recommended operating to accommodate backplane impedances other than 50 $\Omega$ , but must remain within the boundaries of the DC Absolute Maximum Ratings. Similarly,  $V_{REF}$  can be adjusted to optimize noise margin.

## AC Electrical Characteristics

Over recommended range of supply voltage and operating free-air temperature,  $V_{REF} = 1.0V$  (unless otherwise noted).  
 $C_L = 30$  pF for B Port and  $C_L = 50$  pF for C Port.

Symbol	From (Input)	To (Output)	Min	Typ (Note 6)	Max	Unit
$t_{PLH}$ $t_{PHL}$	A	B	1.2 0.8	3.2 2.3	7.3 4.5	ns
$t_{PLH}$ $t_{PHL}$	B	C	1.4 1.6	2.8 2.9	4.4 5.0	ns
$t_{PLH}$ $t_{PHL}$	A	C	1.6 2.0	6.0 5.1	8.1 7.5	ns
$t_{RISE}$	Transition Time, B Outputs (20% to 80%)			1.4		ns
$t_{FALL}$	Transition Time, B Outputs (80% to 20%)			2.0		ns
$t_{RISE}$	Transition Time, C Outputs (10% to 90%)			2.8		ns
$t_{FALL}$	Transition Time, C Outputs (90% to 10%)			2.5		ns
$t_{PZH}$ , $t_{PZL}$ $t_{PHZ}$ , $t_{PLZ}$	$\overline{OEC}$	C	1.2 1.4	2.7 2.8	5.3 4.9	ns
$t_{PLH}$ $t_{PHL}$	OEB	B	1.7 0.5	3.5 2.2	5.9 4.7	ns

**Note 6:** All typical values are at  $V_{CC} = 3.3V$ , and  $T_A = 25^\circ C$ .

### Test Circuits and Timing Waveforms

**Test Circuit for C Outputs**

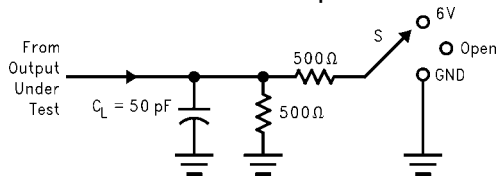

Test	S
$t_{PLH}/t_{PHL}$	OPEN
$t_{PLZ}/t_{PZL}$	6V
$t_{PHZ}/t_{PZH}$	GND

Note:  $C_L$  includes probes and Jig capacitance.

**Test Circuit for B Outputs**

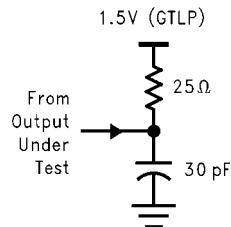

Note:  $C_L$  includes probes and Jig capacitance.

Note: For B Port,  $C_L = 30$  pF is used for worst case.

**Voltage Waveforms Propagation Delay**

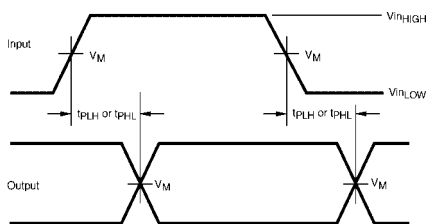

**Voltage Waveform Enable and Disable Times**

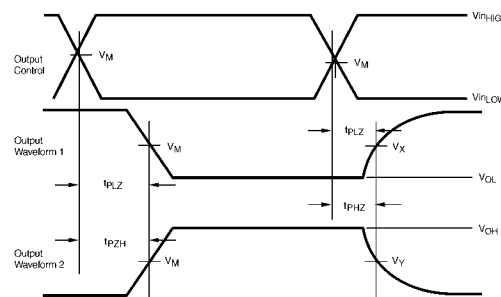

	A or LVTTL Pins	B or GTLP Pins
$V_{INHIGH}$	$V_{CC}$	1.5
$V_{INLOW}$	0.0	0.0
$V_M$	$V_{CC}/2$	1.0
$V_X$	$V_{OL} + 0.3V$	N/A
$V_Y$	$V_{OH} - 0.3V$	N/A

Note: Waveform 1 is for an output with internal conditions such that the output is LOW except when disabled by the output control.

Waveform 2 is for an output with internal conditions such that the output is HIGH except when disabled by the output control.

Note: All input pulses have the following characteristics:

Frequency = 10MHz,  $t_{RISE} = t_{FALL} = 2$  ns (10% to 90%),  $Z_O = 50\Omega$ . The outputs are measured one at a time with one transition per measurement.

**Physical Dimensions** inches (millimeters) unless otherwise noted

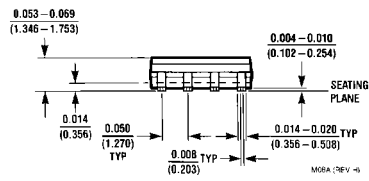
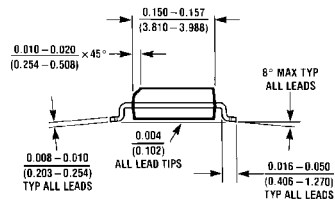
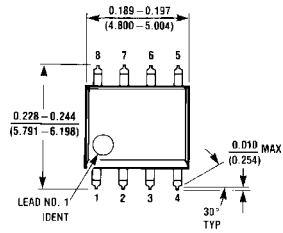

**8-Lead Small Outline Integrated Circuit (SOIC), JEDEC MS-012, 0.150" Narrow  
Package Number M08A**

**Physical Dimensions** inches (millimeters) unless otherwise noted (Continued)

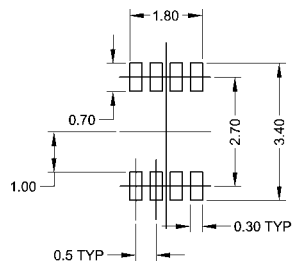
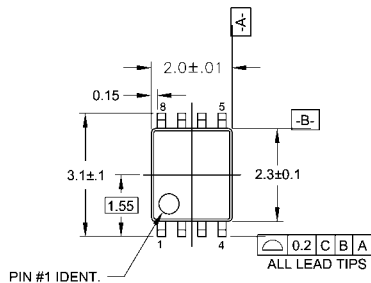

**LAND PATTERN RECOMMENDATION**

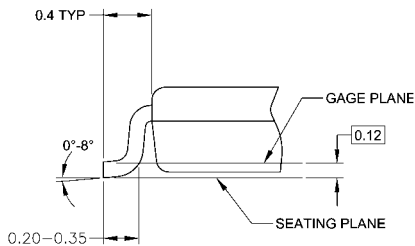
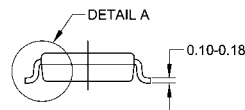
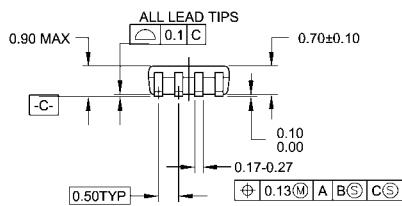

**DETAIL A**

**NOTES:**

- A. CONFORMS TO JEDEC REGISTRATION MO-187
- B. DIMENSIONS ARE IN MILLIMETERS.
- C. DIMENSIONS ARE EXCLUSIVE OF BURRS, MOLD FLASH, AND TIE BAR EXTRUSIONS.
- D. DIMENSIONS AND TOLERANCES PER ANSI Y14.5M, 1982.

MAB08AREVC

**8-Lead US8, JEDEC MO-187, Variation CA 3.1mm Wide  
Package Number MAB08A  
Preliminary**

Fairchild does not assume any responsibility for use of any circuitry described, no circuit patent licenses are implied and Fairchild reserves the right at any time without notice to change said circuitry and specifications.

**LIFE SUPPORT POLICY**

FAIRCHILD'S PRODUCTS ARE NOT AUTHORIZED FOR USE AS CRITICAL COMPONENTS IN LIFE SUPPORT DEVICES OR SYSTEMS WITHOUT THE EXPRESS WRITTEN APPROVAL OF THE PRESIDENT OF FAIRCHILD SEMICONDUCTOR CORPORATION. As used herein:

1. Life support devices or systems are devices or systems which, (a) are intended for surgical implant into the body, or (b) support or sustain life, and (c) whose failure to perform when properly used in accordance with instructions for use provided in the labeling, can be reasonably expected to result in a significant injury to the user.
2. A critical component in any component of a life support device or system whose failure to perform can be reasonably expected to cause the failure of the life support device or system, or to affect its safety or effectiveness.

[www.fairchildsemi.com](http://www.fairchildsemi.com)

## Looking for pricing, stock, or lifecycle information?

Click below to explore more details on WIN SOURCE:

- ⊖ [View GTLP1B151K8X on WIN SOURCE](#)
- ⊖ [Fairchild/ON Semiconductor Information](#)

## Optimize Your Supply Chain with WIN SOURCE Solutions

- ✓ Global Sourcing Solution
- ✓ Obsolete Management
- ✓ Cost Control Management
- ✓ Shortage Management
- ✓ Alternative Solution
- ✓ Excess Inventory Management