



**THE DATASHEET OF  
HCPL0453R2**



# High Speed Transistor Optocouplers

Single Channel:

HCPL0453, HCPL0500, HCPL0501

Dual Channel:

HCPL0531, HCPL0534

## HCPL0453, HCPL0500, HCPL0501, HCPL0531, HCPL0534

### Description

The HCPL05XX, and HCPL04XX optocouplers consist of an AlGaAs LED optically coupled to a high speed photo-detector transistor housed in a compact 8-pin small outline package.

A separate connection for the bias of the photodiode improves the speed by several orders of magnitude over conventional phototransistor optocouplers by reducing the base-collector capacitance of the input transistor. The HCPL04XX devices do not have the base bonded out to a lead for additional noise margin. The HCPL053X devices have two channels per package for optimum mounting density.

### Features

- High Speed – 1 MBit/s
- 15 kV/ $\mu$ s Minimum Common Mode Transient Immunity at  $V_{CM} = 1500$  V (HCPL0453/0534)
- Open Collector Output
- Guaranteed Performance Over Temperature: 0°C to 70°C
- U.L. Recognized (File # E90700)
- VDE0884 Recognized (File # 136616)
  - ♦ Approval Pending for HCPL0531/0453
  - ♦ Ordering Option V, e.g., HCPL0500V
- BSI Recognized (File # 8661, 8662)
  - ♦ HCPL0500/0501 only

### Applications

- Line Receivers
- Pulse Transformer Replacement
- Output Interface to CMOS–LSTTL–TTL
- Wide Bandwidth Analog Coupling

### TRUTH TABLE (Positive Logic)

LED	$V_O$
ON	LOW
OFF	HIGH



ON Semiconductor®

[www.onsemi.com](http://www.onsemi.com)

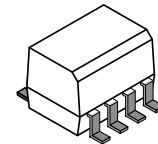

SOIC8  
CASE 751DZ

### MARKING DIAGRAM

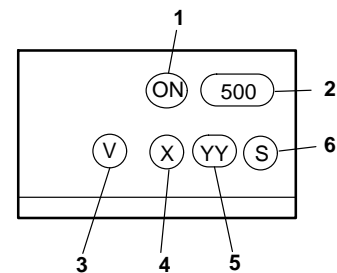

1. ON = ON Semiconductor Logo
2. 500 = Device Number
3. V = VDE mark indicates DIN EN/IEC60747–5–5 approval (Note: Only appears on parts ordered with VDE option – See Ordering Information Table)
4. X = One-Digit Year Code, e.g. '3'
5. YY = Two Digit Work Week Ranging from '01' to '53'
6. S = Assembly Package Code

### ORDERING INFORMATION

See detailed ordering and shipping information on page 7 of this data sheet.

SCHEMATICS

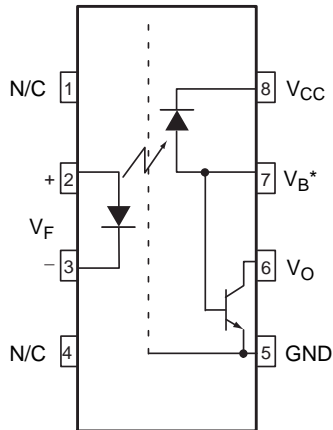

Figure 1. Single-channel Circuit Schematics (HCPL0500, HCPL0501)  
\*Base Not Connected for HCPL0453)

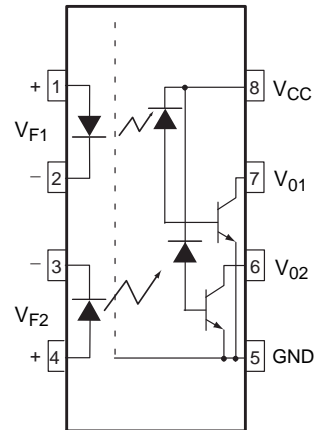

Figure 2. Dual-channel Circuit Schematics (HCPL0531, HCPL0534)

ABSOLUTE MAXIMUM RATINGS ( $T_A = 25^\circ\text{C}$  unless otherwise specified)

Symbol	Parameter	Value	Units
$T_{STG}$	Storage Temperature	-40 to +125	$^\circ\text{C}$
$T_{OPR}$	Operating Temperature	-40 to +85	$^\circ\text{C}$
	Reflow Temperature Profile (Refer to page 7)		

EMITTER

$I_F$ (avg)	DC/Average Forward Input Current	25	mA
$I_F$ (pk)	Peak Forward Input Current (50% duty cycle, 1 ms P.W.)	50	mA
$I_F$ (trans)	Peak Transient Input Current ( $t \leq 1 \mu\text{s}$ P.W., 300 pps)	1.0	A
$V_R$	Reverse Input Voltage	5.0	V
$P_D$	Input Power Dissipation	45	mW

DETECTOR

$I_O$ (avg)	Average Output Current (Pin 6)	8	mA
$I_O$ (pk)	Peak Output Current	16	mA
$V_{EBR}$	Emitter-Base Reverse Voltage (HCPL0500/0501 only)	5	V
$V_{CC}$	Supply Voltage	-0.5 to 30	V
$V_O$	Output Voltage	-0.5 to 20	V
$I_B$	Base Current (HCPL0500/0501 only)	5	mA
$P_D$	Output Power Dissipation	100	mW

Stresses exceeding those listed in the Maximum Ratings table may damage the device. If any of these limits are exceeded, device functionality should not be assumed, damage may occur and reliability may be affected.

# HCPL0453, HCPL0500, HCPL0501, HCPL0531, HCPL0534

## ELECTRICAL CHARACTERISTICS (T<sub>A</sub> = 0°C to 70°C unless otherwise specified)

### INDIVIDUAL COMPONENT CHARACTERISTICS

Symbol	Parameter	Test Conditions	Device	Min.	Typ.*	Max.	Unit
<b>EMITTER</b>							
V <sub>F</sub>	Input Forward Voltage	I <sub>F</sub> = 16 mA, T <sub>A</sub> = 25°C	All		1.45	1.7	V
		I <sub>F</sub> = 16 mA				1.8	
BV <sub>R</sub>	Input Reverse Breakdown Voltage	I <sub>R</sub> = 10 μA	All	5.0			V
ΔV <sub>F</sub> / ΔT <sub>A</sub>	Temperature Coefficient of Forward Voltage	I <sub>F</sub> = 16 mA	All		-1.6		mV/°C

### DETECTOR

I <sub>OH</sub>	Logic High Output Current	I <sub>F</sub> = 0 mA, V <sub>O</sub> = V <sub>CC</sub> = 5.5 V, T <sub>A</sub> = 25°C	All		0.001	0.5	μA
		I <sub>F</sub> = 0 mA, V <sub>O</sub> = V <sub>CC</sub> = 15 V, T <sub>A</sub> = 25°C	All		0.005	1	
		I <sub>F</sub> = 0 mA, V <sub>O</sub> = V <sub>CC</sub> = 15 V	All			50	
I <sub>CCL</sub>	Logic Low Supply Current	I <sub>F</sub> = 16 mA, V <sub>O</sub> = Open, V <sub>CC</sub> = 15 V	HCPL0453/ 0500/1		120	200	μA
			HCPL0531/4			400	
I <sub>CCH</sub>	Logic High Supply Current	I <sub>F</sub> = 0 mA, V <sub>O</sub> = Open, V <sub>CC</sub> = 15 V, T <sub>A</sub> = 25°C	All		0.01	1	μA
			HCPL0453/ 0500/1			2	
			HCPL0531/4			4	

### TRANSFER CHARACTERISTICS

Symbol	Parameter	Test Conditions	Device	Min.	Typ.*	Max.	Unit
<b>COUPLED</b>							
CTR	Current Transfer Ratio (Note 1)	I <sub>F</sub> = 16 mA, V <sub>O</sub> = 0.4 V, V <sub>CC</sub> = 4.5 V, T <sub>A</sub> = 25°C	HCPL0500	7	27	50	%
			HCPL0453	19	27	50	
			HCPL0501/0531				
		I <sub>F</sub> = 16 mA, V <sub>O</sub> = 0.5 V, V <sub>CC</sub> = 4.5 V	HCPL0500	5	30		
			HCPL0453	15	30		
			HCPL0501/0534				
V <sub>OL</sub>	Logic Low Output Voltage	I <sub>F</sub> = 16 mA, I <sub>O</sub> = 1.1 mA, V <sub>CC</sub> = 4.5 V, T <sub>A</sub> = 25°C	HCPL0500		0.18	0.4	V
			HCPL0453		0.25	0.4	
		HCPL0501/0531/4					
		I <sub>F</sub> = 16 mA, I <sub>O</sub> = 0.8 mA, V <sub>CC</sub> = 4.5 V	HCPL0500		0.13	0.5	
			HCPL0453		0.23	0.5	
		HCPL0501/0531/4					

\*All typicals at T<sub>A</sub> = 25°C

# HCPL0453, HCPL0500, HCPL0501, HCPL0531, HCPL0534

## ELECTRICAL CHARACTERISTICS (CONTINUED) ( $T_A = 0^\circ\text{C}$ to $70^\circ\text{C}$ unless otherwise specified)

### SWITCHING CHARACTERISTICS ( $V_{CC} = 5\text{ V}$ )

Symbol	Parameter	Test Conditions	Device	Min.	Typ.*	Max.	Unit
$T_{PHL}$	Propagation Delay Time to Logic LOW	$T_A = 25^\circ\text{C}$ , $R_L = 4.1\text{ k}\Omega$ , $I_F = 16\text{ mA}$ (Note 2) (Fig. 9)	HCPL0500		0.45	1.5	$\mu\text{s}$
		$R_L = 1.9\text{ k}\Omega$ , $I_F = 16\text{ mA}$ , $T_A = 25^\circ\text{C}$ (Note 3) (Fig. 9)	HCPL0453		0.45	0.8	
			HCPL0501/0531/4				
		$R_L = 4.1\text{ k}\Omega$ , $I_F = 16\text{ mA}$ (Note 2) (Fig. 9)	HCPL0500			2.0	
$T_{PLH}$	Propagation Delay Time to Logic HIGH	$T_A = 25^\circ\text{C}$ , $R_L = 4.1\text{ k}\Omega$ , $I_F = 16\text{ mA}$ (Note 2) (Fig. 9)	HCPL0500		0.5	1.5	$\mu\text{s}$
		$R_L = 1.9\text{ k}\Omega$ , $I_F = 16\text{ mA}$ , $T_A = 25^\circ\text{C}$ (Note 3) (Fig. 9)	HCPL0453		0.3	0.8	
			HCPL0501/0531/4				
		$R_L = 4.1\text{ k}\Omega$ , $I_F = 16\text{ mA}$ (Note 2) (Fig. 9)	HCPL0500			2.0	
$ CM_H $	Common Mode Transient Immunity at Logic HIGH	$I_F = 0\text{ mA}$ , $V_{CM} = 10\text{ V}_{P-P}$ , $R_L = 4.1\text{ k}\Omega$ , $T_A = 25^\circ\text{C}$ (Note 4) (Fig. 10)	HCPL0500	1,000	10,000		$\text{V}/\mu\text{s}$
		$I_F = 0\text{ mA}$ , $V_{CM} = 10\text{ V}_{P-P}$ , $R_L = 1.9\text{ k}\Omega$ , $T_A = 25^\circ\text{C}$ (Note 4) (Fig. 10)	HCPL0501/31	1,000	10,000		
			HCPL0534	15,000	40,000		
		$I_F = 0\text{ mA}$ , $V_{CM} = 1500\text{ V}_{P-P}$ , $R_L = 1.9\text{ k}\Omega$ , $T_A = 25^\circ\text{C}$ (Note 4) (Fig. 10)	HCPL0453	15,000	40,000		
$ CM_L $	Common Mode Transient Immunity at Logic LOW	$I_F = 16\text{ mA}$ , $V_{CM} = 10\text{ V}_{P-P}$ , $R_L = 4.1\text{ k}\Omega$ , $T_A = 25^\circ\text{C}$ (Note 4) (Fig. 10)	HCPL0500	1,000	10,000		$\text{V}/\mu\text{s}$
		$I_F = 16\text{ mA}$ , $V_{CM} = 10\text{ V}_{P-P}$ , $R_L = 1.9\text{ k}\Omega$ (Note 4) (Fig. 10)	HCPL0501/31	1,000	10,000		
			HCPL0534	15,000	40,000		
		$I_F = 16\text{ mA}$ , $T_A = 25^\circ\text{C}$ , $V_{CM} = 1500\text{ V}_{P-P}$ , $R_L = 1.9\text{ k}\Omega$ (Note 4) (Fig. 10)	HCPL0453	15,000	40,000		

### ISOLATION CHARACTERISTICS

Symbol	Characteristics	Test Conditions	Min.	Typ.*	Max.	Unit
$V_{ISO}$	Input–Output Isolation Voltage	$f = 60\text{ Hz}$ , $t = 1.0\text{ min.}$ , $I_{I-O} \leq 2\text{ }\mu\text{A}$ (Notes 5, 6)	2500			$\text{V}_{AC\text{RMS}}$
$R_{ISO}$	Isolation Resistance	$V_{I-O} = 500\text{ V}$ (Note 5)	$10^{11}$			
$C_{ISO}$	Isolation Capacitance	$V_{I-O} = 0\text{ V}$ , $f = 1.0\text{ MHz}$ (Note 5)		0.2		$\text{pF}$

Product parametric performance is indicated in the Electrical Characteristics for the listed test conditions, unless otherwise noted. Product performance may not be indicated by the Electrical Characteristics if operated under different conditions.

\*All typicals at  $T_A = 25^\circ\text{C}$

- Current Transfer Ratio is designed as a ratio of output collector current,  $I_O$ , to the forward LED input current,  $I_F$ , times 100%.
- The 4.1 k $\Omega$  load represents 1 LSTTL unit load of 0.36 mA and 6.1 k $\Omega$  pull-up resistor.
- The 1.9 k $\Omega$  load represents 1 TTL unit load of 1.6 mA and 5.6 k $\Omega$  pull-up resistor.
- Common mode transient immunity in logic high level is the maximum tolerable (positive)  $dV_{cm}/dt$  on the leading edge of the common mode pulse signal  $V_{CM}$ , to assure that the output will remain in a logic high state (i.e.,  $V_O > 2.0\text{ V}$ ). Common mode transient immunity in logic low level is the maximum tolerable (negative)  $dV_{cm}/dt$  on the trailing edge of the common mode pulse signal,  $V_{CM}$ , to assure that the output will remain in a logic low state (i.e.,  $V_O < 0.8\text{ V}$ ).
- Device is considered a two terminal device: Pins 1, 2, 3 and 4 are shorted together and Pins 5, 6, 7 and 8 are shorted together.
- 2500 VAC RMS for 1 minute duration is equivalent to 3000 VAC RMS for 1 second duration.

TYPICAL PERFORMANCE CURVES

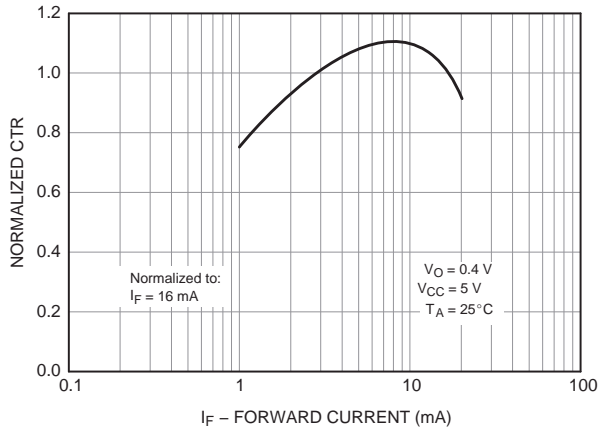

Figure 3. Normalized CTR vs. Forward Current

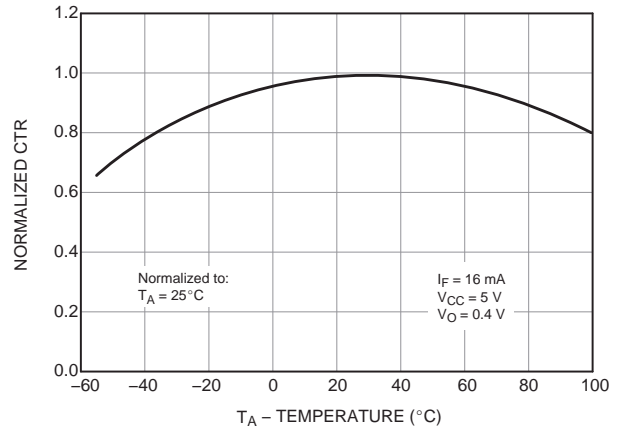

Figure 4. Normalized CTR vs. Temperature

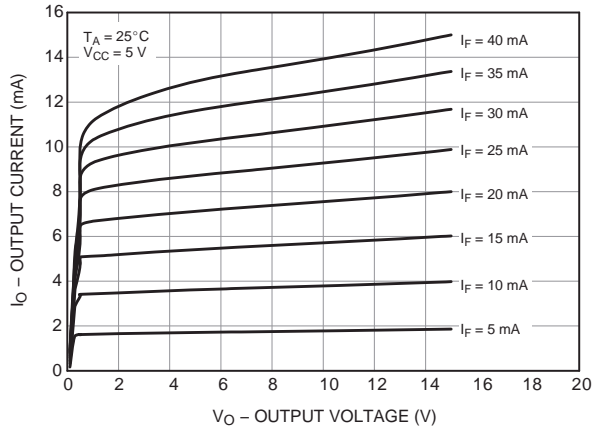

Figure 5. Output Current vs. Output Voltage

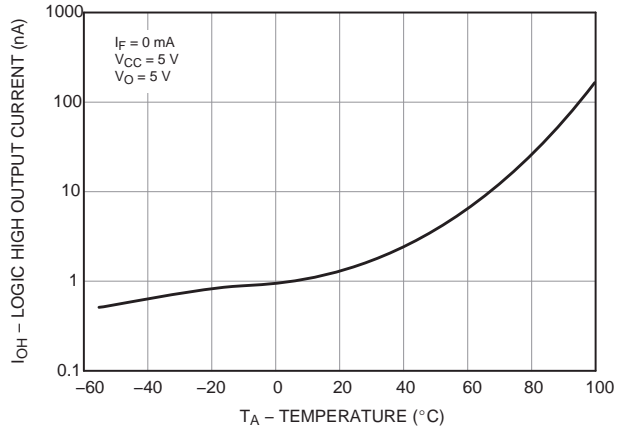

Figure 6. Logic High Output Current vs. Temperature

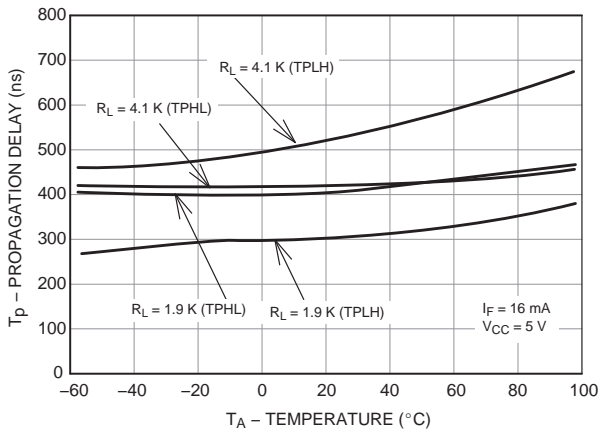

Figure 7. Propagation Delay vs. Temperature

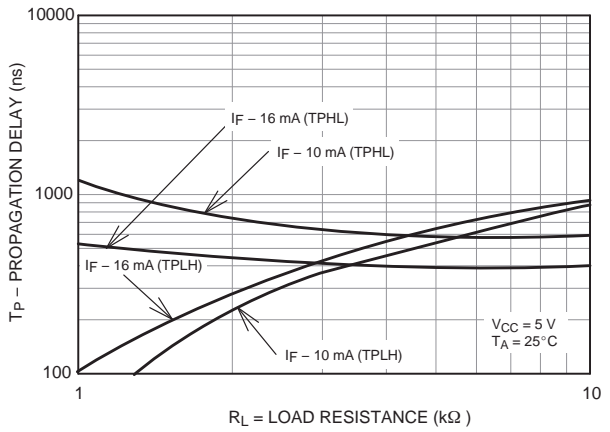
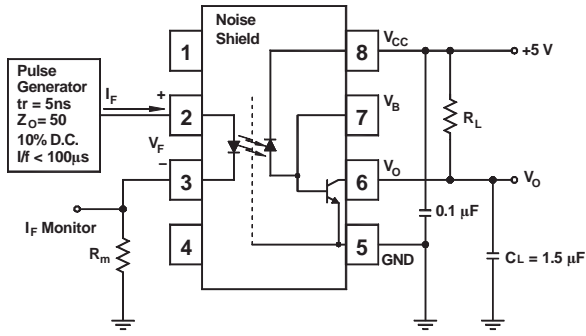
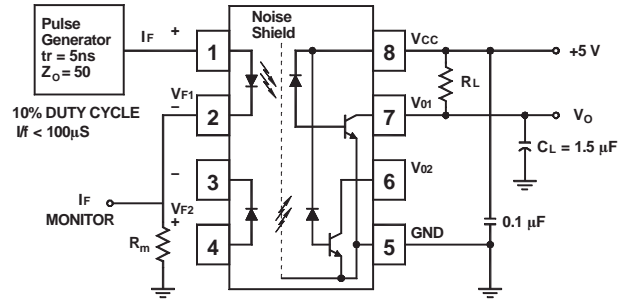

Figure 8. Propagation Delay vs. Load Resistance

# HCPL0453, HCPL0500, HCPL0501, HCPL0531, HCPL0534



Test Circuit for HCPL0453, HCPL0500 and HCPL0501



Test Circuit for HCPL0531 and HCPL0534

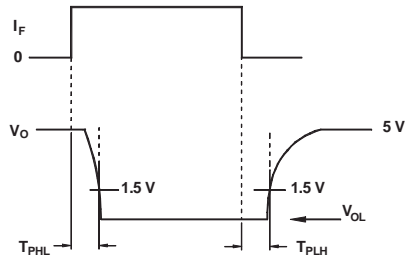
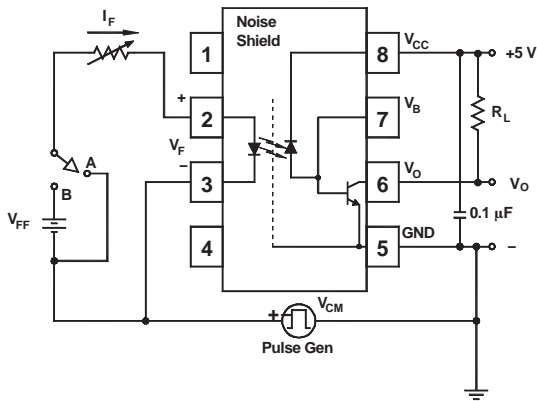
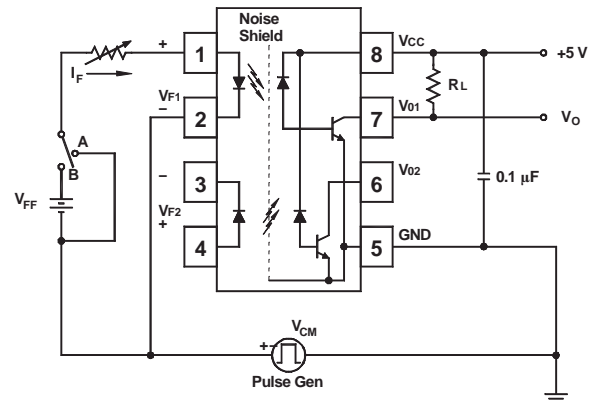

Figure 9. Switching Time Test Circuit



Test Circuit for HCPL0453, HCPL0500 and HCPL0501



Test Circuit for HCPL0531 and HCPL0534

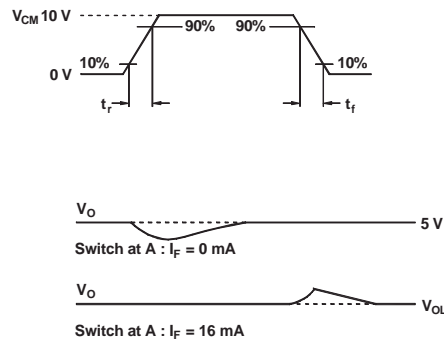

Figure 10. Common Mode Immunity Test Circuit

# HCPL0453, HCPL0500, HCPL0501, HCPL0531, HCPL0534

## ORDERING INFORMATION

Part Nr./ Option (Note 7)	Order Entry Identifier	Package	Description	Packing Method†
HCPL0xxxV	V	SOIC8	VDE 0884 (approval pending for HCPL0531 & HCPL0534)	Tube (3000 Units)
HCPL0xxxR2	R2	SOIC8		Tape and Reel (2500 Units)
HCPL0xxxR2V	R2V	SOIC8	VDE 0884 (approval pending for HCPL0531 & HCPL0534)	Tape and Reel (2500 Units)

†For information on tape and reel specifications, including part orientation and tape sizes, please refer to our Tape and Reel Packaging Specifications Brochure, BRD8011/D.

7. The product orderable part number system listed in this table also applies to the HCPL0453, HCPL0500, HCPL0501, HCPL0531 and HCPL0534 product.

## REFLOW PROFILE

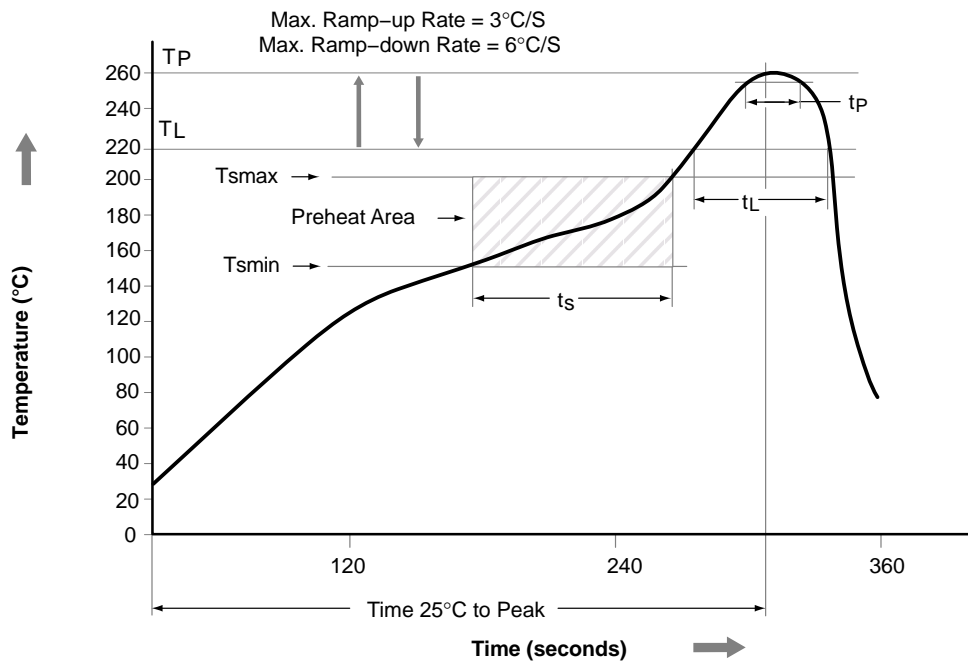

Profile Feature	Pb-Free Assembly Profile
Temperature Min. (T Amin)	150°C
Temperature Max. (Tsmax)	200°C
Time (ts) from (T Amin to Tsmax)	60–120 seconds
Ramp-up Rate (tL to tp)	3°C/second max.
Liquidous Temperature (TL)	217°C
Time (tL) Maintained Above (TL)	60–150 seconds
Peak Body Package Temperature	260°C +0°C / -5°C
Time (tp) within 5°C of 260°C	30 seconds
Ramp-down Rate (TP to TL)	6°C/second max.
Time 25°C to Peak Temperature	8 minutes max.

# MECHANICAL CASE OUTLINE

## PACKAGE DIMENSIONS

ON Semiconductor®



**SOIC8**  
CASE 751DZ  
ISSUE O

DATE 30 SEP 2016

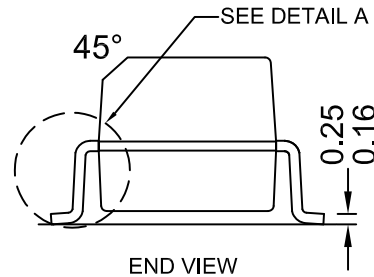
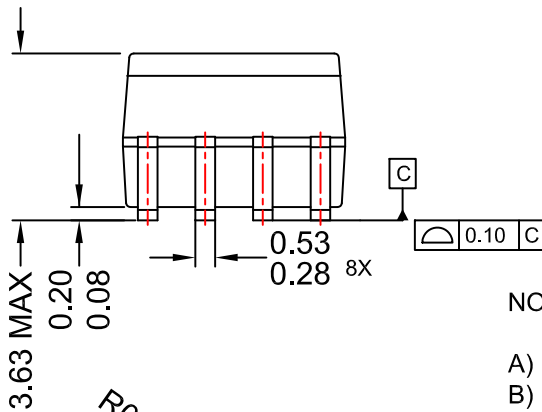
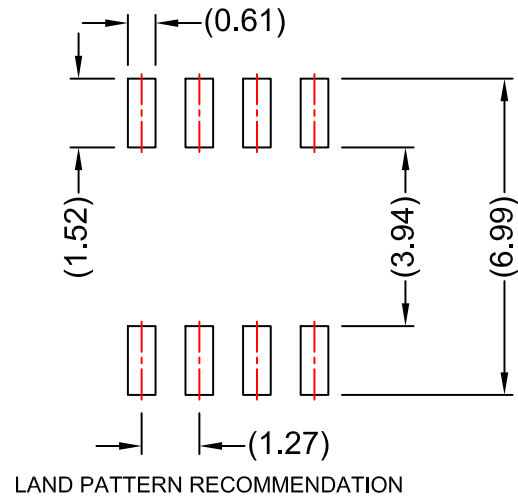
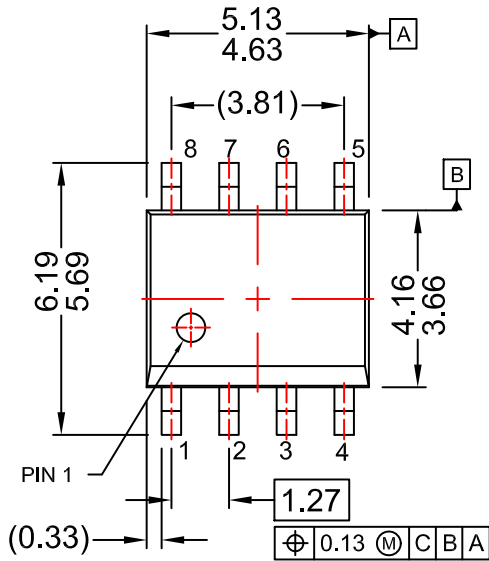

**NOTES:**

- A) NO STANDARD APPLIES TO THIS PACKAGE
- B) ALL DIMENSIONS ARE IN MILLIMETERS.
- C) DIMENSIONS DO NOT INCLUDE MOLD FLASH OR BURRS.
- D) LANDPATTERN STANDARD: SOIC127P600X175-8M.

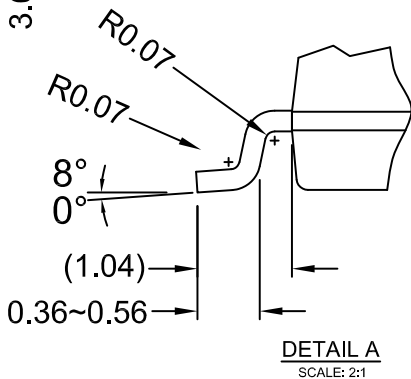

<b>DOCUMENT NUMBER:</b>	<b>98AON13733G</b>	Electronic versions are uncontrolled except when accessed directly from the Document Repository. Printed versions are uncontrolled except when stamped "CONTROLLED COPY" in red.
<b>DESCRIPTION:</b>	<b>SOIC8</b>	<b>PAGE 1 OF 1</b>

ON Semiconductor and are trademarks of Semiconductor Components Industries, LLC dba ON Semiconductor or its subsidiaries in the United States and/or other countries. ON Semiconductor reserves the right to make changes without further notice to any products herein. ON Semiconductor makes no warranty, representation or guarantee regarding the suitability of its products for any particular purpose, nor does ON Semiconductor assume any liability arising out of the application or use of any product or circuit, and specifically disclaims any and all liability, including without limitation special, consequential or incidental damages. ON Semiconductor does not convey any license under its patent rights nor the rights of others.

**onsemi**, **Onsemi**, and other names, marks, and brands are registered and/or common law trademarks of Semiconductor Components Industries, LLC dba "**onsemi**" or its affiliates and/or subsidiaries in the United States and/or other countries. **onsemi** owns the rights to a number of patents, trademarks, copyrights, trade secrets, and other intellectual property. A listing of **onsemi**'s product/patent coverage may be accessed at [www.onsemi.com/site/pdf/Patent-Marking.pdf](http://www.onsemi.com/site/pdf/Patent-Marking.pdf). **onsemi** reserves the right to make changes at any time to any products or information herein, without notice. The information herein is provided "as-is" and **onsemi** makes no warranty, representation or guarantee regarding the accuracy of the information, product features, availability, functionality, or suitability of its products for any particular purpose, nor does **onsemi** assume any liability arising out of the application or use of any product or circuit, and specifically disclaims any and all liability, including without limitation special, consequential or incidental damages. Buyer is responsible for its products and applications using **onsemi** products, including compliance with all laws, regulations and safety requirements or standards, regardless of any support or applications information provided by **onsemi**. "Typical" parameters which may be provided in **onsemi** data sheets and/or specifications can and do vary in different applications and actual performance may vary over time. All operating parameters, including "Typicals" must be validated for each customer application by customer's technical experts. **onsemi** does not convey any license under any of its intellectual property rights nor the rights of others. **onsemi** products are not designed, intended, or authorized for use as a critical component in life support systems or any FDA Class 3 medical devices or medical devices with a same or similar classification in a foreign jurisdiction or any devices intended for implantation in the human body. Should Buyer purchase or use **onsemi** products for any such unintended or unauthorized application, Buyer shall indemnify and hold **onsemi** and its officers, employees, subsidiaries, affiliates, and distributors harmless against all claims, costs, damages, and expenses, and reasonable attorney fees arising out of, directly or indirectly, any claim of personal injury or death associated with such unintended or unauthorized use, even if such claim alleges that **onsemi** was negligent regarding the design or manufacture of the part. **onsemi** is an Equal Opportunity/Affirmative Action Employer. This literature is subject to all applicable copyright laws and is not for resale in any manner.

---

## ADDITIONAL INFORMATION

### TECHNICAL PUBLICATIONS:

Technical Library: [www.onsemi.com/design/resources/technical-documentation](http://www.onsemi.com/design/resources/technical-documentation)  
onsemi Website: [www.onsemi.com](http://www.onsemi.com)

### ONLINE SUPPORT: [www.onsemi.com/support](http://www.onsemi.com/support)

For additional information, please contact your local Sales Representative at [www.onsemi.com/support/sales](http://www.onsemi.com/support/sales)

## Looking for pricing, stock, or lifecycle information?

Click below to explore more details on WIN SOURCE:

- ⊖ [View HCPL0453R2 on WIN SOURCE](#)
- ⊖ [Fairchild/ON Semiconductor Information](#)

## Optimize Your Supply Chain with WIN SOURCE Solutions

- ✓ Global Sourcing Solution
- ✓ Obsolete Management
- ✓ Cost Control Management
- ✓ Shortage Management
- ✓ Alternative Solution
- ✓ Excess Inventory Management