

TPS7H1101A-SP 1.5-V to 7-V Input, 3-A, Radiation-Hardened LDO Regulator

1 Features

- [5962R13202](#) ⁽¹⁾:
 - Radiation hardness assurance (RHA) qualified up to total ionizing dose (TID) 100 krad(Si)
 - ELDRS-free: 100 krad(Si)
 - Dose rate: 10 mrad(Si)/s
 - Single event latch-up (SEL) immune to LET = 85 MeV-cm²/mg
 - SEB and SEGR immune to LET = 85 MeV-cm²/mg
 - SET/SEFI onset threshold > 40 MeV-cm²/mg ⁽²⁾
 - Specifically designed to always upset low to avoid damage to critical downstream component
 - SET/SEFI cross-section plot ⁽²⁾
- Ultra-low V_{IN} range: 1.5 V to 7 V
- 3-A maximum output current
- Current share/parallel operation to provide up to 6-A output current
- Stable with ceramic output capacitor
- ±2% accuracy over line, load, and temperature
- Programmable soft start through external capacitor
- Input enable across all input voltages and power-good output for power sequencing
- Ultra-low dropout LDO voltage: 62 mV at 1 A (25°C), V_{OUT} = 1.8 V
- Low noise: 20.33 μVRMS, V_{IN} = 2 V, V_{OUT} = 1.8 V at 3 A
- PSRR: over 45 dB at 1 kHz
- Excellent load/line transient response
- Foldback current limit
- See the [Design and development](#) tab
- Thermally-enhanced CFP package, 0.4° C/W R_{θJC}

2 Applications

- Space satellite point of load supply for FPGAs, microcontrollers, ASICs, and data converters
- Radiation-hardened low-noise linear regulator power supply for RF, VCOs, receivers, and amplifiers
- Clean analog supply requirements
- [Command and data handling \(C&DH\)](#)
- [Optical imaging payload](#)
- [Radar imaging payload](#)
- [Satellite electrical power system \(EPS\)](#)

3 Description

The TPS7H1101A-SP is an improved version of the TPS7H1101-SP allowing the use of the enable feature across the entire input voltage range. It is a radiation-hardened LDO linear regulator that uses a

PMOS pass element configuration. It operates over a wide range of input voltage, from 1.5 V to 7 V while offering excellent PSRR. The TPS7H1101A-SP features a precise and programmable foldback current limit implementation with a very-wide adjustment range. To support the complex power requirements of FPGAs, DSPs, or microcontrollers, the TPS7H1101A-SP provides enable on and off functionality, programmable soft start, current sharing capability, and a Power Good open-drain output.

Device Information

PART NUMBER ⁽¹⁾	GRADE	PACKAGE
5962R1320202V9A	KGD Flight Grade RHA 100 krad(Si)	16-Pin CFP 9.60 mm × 11.00 mm Weight: 1.55 g ⁽⁴⁾
5962R1320202VXC	Flight Grade RHA 100 krad(Si)	
TPS7H1101HKR/EM	Engineering Modules ⁽³⁾ ⁽⁵⁾	
TPS7H1101AHR/EM	Engineering Modules ⁽³⁾	
TPS7H1101SPEVM	Ceramic Evaluation Board	EVM

- (1) For all available packages, see the orderable addendum at the end of the data sheet.
- (2) See [Radiation Report](#) (SNA257) for details.
- (3) These units are intended for engineering evaluation only. They are processed to a noncompliant flow (that is, no burn-in, and so forth) and are tested to a temperature rating of 25°C only. These units are not suitable for qualification, production, radiation testing or flight use. Parts are not warranted for performance over the full MIL specified temperature range of –55°C to 125°C or operating life.
- (4) Weight is accurate to ±10%.
- (5) TPS7H1101HKR/EM with device Date Code newer than 1705 is equivalent to TPS7H1101AHR/EM using rev A silicon.

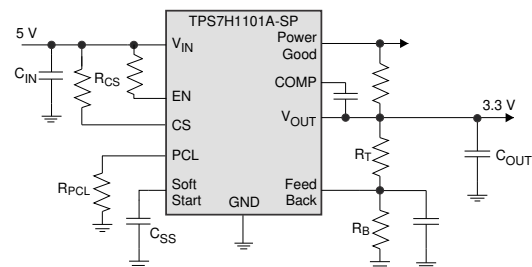

Copyright © 2017, Texas Instruments Incorporated

Typical Application Circuit



Table of Contents

1 Features	1	8 Application and Implementation	14
2 Applications	1	8.1 Application Information.....	14
3 Description	1	8.2 Typical Application.....	15
4 Revision History	2	9 Power Supply Recommendations	26
5 Pin Configuration and Functions	3	10 Layout	26
6 Specifications	6	10.1 Layout Guidelines.....	26
6.1 Absolute Maximum Ratings.....	6	10.2 Layout Example.....	26
6.2 ESD Ratings.....	6	11 Device and Documentation Support	27
6.3 Recommended Operating Conditions.....	6	11.1 Device Support.....	27
6.4 Thermal Information.....	6	11.2 Documentation Support.....	27
6.5 Electrical Characteristics.....	7	11.3 Receiving Notification of Documentation Updates..	27
6.6 Typical Characteristics.....	10	11.4 Support Resources.....	27
7 Detailed Description	12	11.5 Trademarks.....	27
7.1 Overview.....	12	11.6 Electrostatic Discharge Caution.....	27
7.2 Functional Block Diagram.....	12	11.7 Glossary.....	27
7.3 Feature Description.....	13	12 Mechanical, Packaging, and Orderable Information	27
7.4 Device Functional Modes.....	13		

4 Revision History

NOTE: Page numbers for previous revisions may differ from page numbers in the current version.

Changes from Revision B (June 2020) to Revision C (April 2021)	Page
• Updated the numbering format for tables, figures, and cross-references throughout the document.....	1
• Added TPS7H1101AHKR/EM to Device Information table.....	1

Changes from Revision A (August 2017) to Revision B (June 2020)	Page
• Added package weight to Device Information table.....	1
• Added note to Pin Functions table for thermal pad and lid.....	3
• Added updated thermal metrics in <i>Thermal Information</i> table.....	6
• Changed and relaxed V_{CS} operating range.....	7
• Added table note for V_{CS}	7
• Changed CSR ratio. Added limits by temperature.....	7
• Added clarification for T_{EN}	7
• Changed <i>Overview</i> section for improved clarity.....	12
• Changed and clarified V_{REF} voltage in C_{SS} calculation.....	13
• Changed <i>Stability</i> applications section.....	14
• Changed and corrected <i>PCL</i> section description.....	16
• Changed and clarified <i>High-Side Current Sense</i> section description.....	17
• Changed and clarified <i>Current Foldback</i> section description.....	19
• Changed and improved <i>Layout Example</i> section.....	26

Changes from Revision * (April 2017) to Revision A (August 2017)	Page
• Added Bare Die Information table.....	3
• Added Bond Pad Coordinates in Microns table.....	3

5 Pin Configuration and Functions

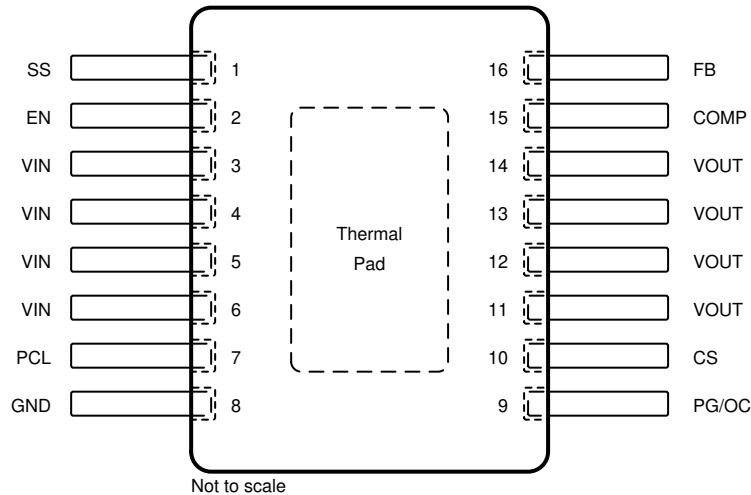

**Figure 5-1. HKR Package
16-Pin CFP
Bottom View**

Table 5-1. Pin Functions

PIN		I/O	DESCRIPTION			
NAME	NO.					
SS	1	I/O	Soft-start terminal. Connecting an external capacitor slows down the output voltage ramp rate after enable event.			
EN	2	I	Enable terminal. Driving this terminal to logic high enables the device; driving the terminal to logic low disables the device.			
V _{IN}	3	I	Unregulated supply voltage. TI recommends to connect an input capacitor as a good analog circuit practice.			
	4					
	5					
	6					
PCL	7	I/O	Programmable current limit. A resistor to GND sets the overcurrent limit activation point. The range of resistor that can be used on the PCL terminal to GND is 8.2 kΩ to 160 kΩ.			
GND	8	—	Ground/thermal pad. ^{(1) (2)}			
PG/OC	9	O	Power Good terminal. PG is an open-drain output to indicate the output voltage reaches 90% of target. PG terminal is also used as indicator when an overcurrent condition is activated. PG pin should have a pull-up resistor to the V _{OUT} pin.			
CS	10	I/O	Current sense terminal. Resistor connected from CS to V _{IN} . CS terminal indicates voltage proportional to output current. CS terminal low: Foldback current limit disabled. CS terminal high: Foldback current limit enabled.			
				O	Regulated output.	
						11
						12
13						
V _{OUT}	14					
	COMP	15	I/O	Internal compensation point for error amplifier.		
FB	16	I	The output voltage feedback input through voltage dividers. See Section 8.2.1.1 .			

(1) Thermal pad must be connected to GND.

(2) Thermal pad and package lid are internally connected to GND.

Table 5-2. Bare Die Information

DIE THICKNESS	BACKSIDE FINISH	BACKSIDE POTENTIAL	BOND PAD METALLIZATION COMPOSITION	BOND PAD THICKNESS
15 mils	Silicon with backgrind	Ground	AlCu	30 kÅ

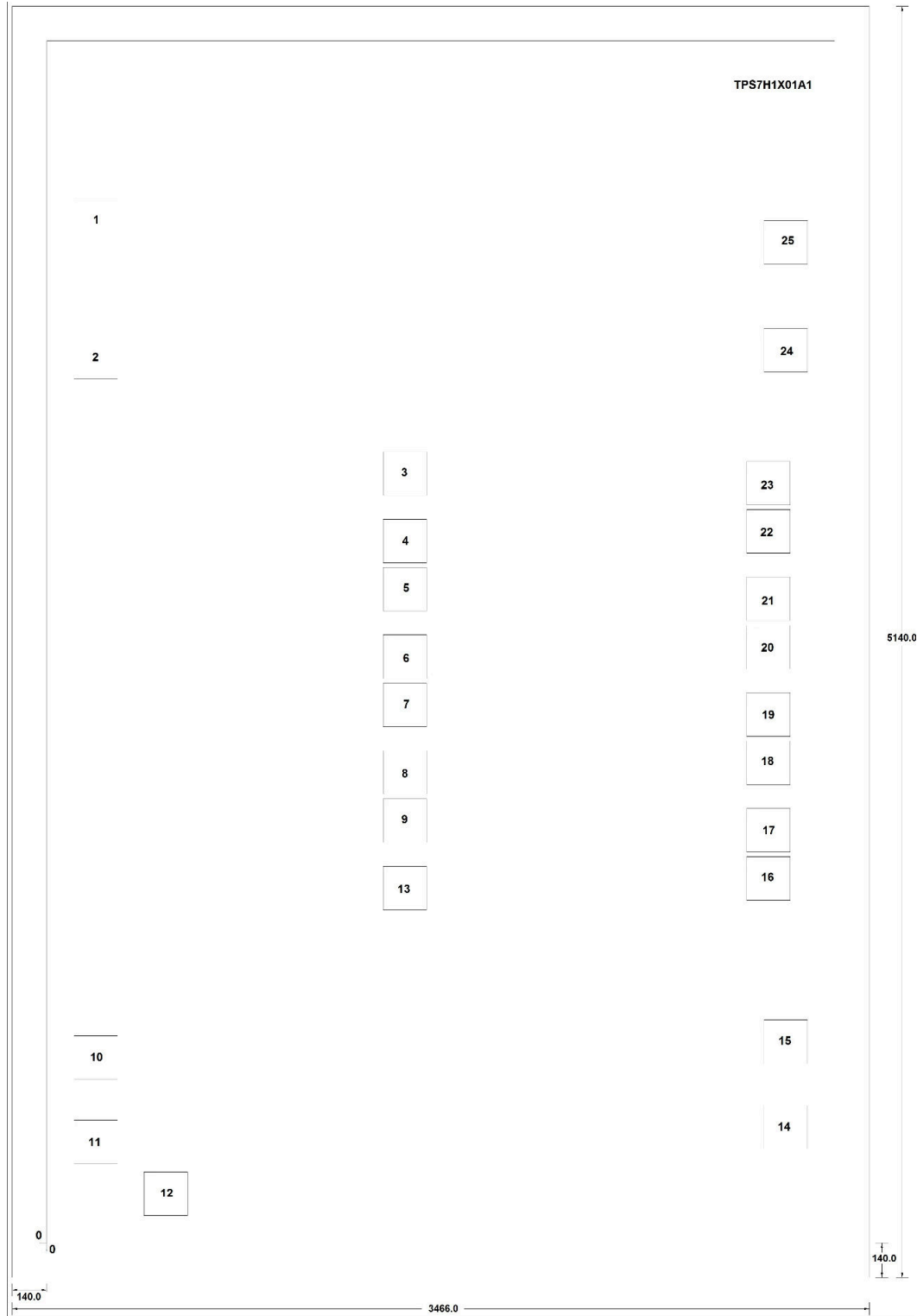

All dimensions are in microns.

Table 5-3. Bond Pad Coordinates in Microns

DESCRIPTION	PAD NUMBER	X MIN	Y MIN	X MAX	Y MAX
SS	1	109.89	4046.805	287.19	4224.105
EN	2	109.89	3493.35	287.19	3670.65
VIN	3	1359.99	3021.345	1537.29	3198.645
VIN	4	1359.99	2749.005	1537.29	2926.305
VIN	5	1359.99	2553.705	1537.29	2731.005
VIN	6	1359.99	2281.365	1537.29	2458.665
VIN	7	1359.99	2086.065	1537.29	2263.365
VIN	8	1359.99	1813.725	1537.29	1991.025
VIN	9	1359.99	1618.425	1537.29	1795.725
PCL	10	109.89	660.285	287.19	837.585
GND	11	109.89	319.455	287.19	496.755
GND	12	392.58	109.935	569.88	287.235
VIN	13	1359.99	1346.085	1537.29	1523.385
PG/OC	14	2898.945	379.62	3076.245	556.92
CS	15	2898.945	724.32	3076.245	901.62
VOUT	16	2829.105	1384.695	3006.405	1561.995
VOUT	17	2829.105	1579.815	3006.405	1757.115
VOUT	18	2829.105	1852.335	3006.405	2029.635
VOUT	19	2829.105	2047.455	3006.405	2224.755
VOUT	20	2829.105	2319.975	3006.405	2497.275
VOUT	21	2829.105	2515.095	3006.405	2692.395
VOUT	22	2829.105	2787.615	3006.405	2964.915
VOUT	23	2829.105	2982.735	3006.405	3160.035
COMP	24	2898.945	3519.72	3076.245	3697.02
FB	25	2898.945	3956.535	3076.245	4133.835

6 Specifications

6.1 Absolute Maximum Ratings

over operating free-air temperature range (unless otherwise noted) ⁽¹⁾

		MIN	MAX	UNIT
Input voltage	V _{IN} , PG	-0.3	7.5	V
	FB, COMP, PCL, CS, EN	-0.3	V _{IN} + 0.3	
Output voltage	V _{OUT} , SS	-0.3	7.5	V
PG terminal sink current		0.001	5	mA
Maximum operating junction temperature, T _J		-55	150	°C
Storage temperature, T _{stg}		-55	150	°C

- (1) Stresses beyond those listed under *Absolute Maximum Ratings* may cause permanent damage to the device. These are stress ratings only, which do not imply functional operation of the device at these or any other conditions beyond those indicated under *Recommended Operating Conditions*. Exposure to absolute-maximum-rated conditions for extended periods may affect device reliability.

6.2 ESD Ratings

		VALUE	UNIT
V _(ESD) Electrostatic discharge	Human-body model (HBM), per ANSI/ESDA/JEDEC JS-001, all pins ⁽¹⁾	±2000	V
	Charged-device model (CDM), per JEDEC specification JESD22-C101, all pins ⁽²⁾	±1000	

- (1) JEDEC document JEP155 states that 500-V HBM allows safe manufacturing with a standard ESD control process.
 (2) JEDEC document JEP157 states that 250-V CDM allows safe manufacturing with a standard ESD control process.

6.3 Recommended Operating Conditions

over operating free-air temperature range (unless otherwise noted)

		MIN	NOM	MAX	UNIT
T _J	Operating junction temperature	-55		125	°C

6.4 Thermal Information

THERMAL METRIC ⁽¹⁾ ⁽²⁾ ⁽³⁾		TPS7H1101A-SP		UNIT
		HKR (CFP)		
		16 PINS		
R _{θ JA}	Junction-to-ambient thermal resistance	24.3		°C/W
R _{θ JC(top)}	Junction-to-case (top) thermal resistance	5.5		°C/W
R _{θ JB}	Junction-to-board thermal resistance	8.1		°C/W
ψ _{JT}	Junction-to-top characterization parameter	1.3		°C/W
ψ _{JB}	Junction-to-board characterization parameter	8.1		°C/W
R _{θ JC(bot)}	Junction-to-case (bottom) thermal resistance	0.4		°C/W

- (1) For more information about traditional and new thermal metrics, see the *Semiconductor and IC Package Thermal Metrics* application report, [SPRA953](#).
 (2) Do not allow package body temperature to exceed 265°C at any time or permanent damage may result.
 (3) Maximum power dissipation may be limited by overcurrent protection.

6.5 Electrical Characteristics

$1.5\text{ V} \leq V_{\text{IN}} \leq 7\text{ V}$, $V_{\text{OUT(target)}} = V_{\text{IN}} - 0.35\text{ V}$, $I_{\text{OUT}} = 10\text{ mA}$, $V_{\text{EN}} = 1.1\text{ V}$, $C_{\text{OUT}} = 22\text{ }\mu\text{F}$, PG terminal pulled up to V_{IN} with $50\text{ k}\Omega$, over operating temperature range ($T_{\text{J}} = -55^{\circ}\text{C}$ to 125°C), unless otherwise noted. Typical values are at $T_{\text{J}} = 25^{\circ}\text{C}$.

PARAMETER		TEST CONDITIONS	MIN	TYP	MAX	UNIT
V_{IN}	Input voltage range		1.5		7	V
V_{FB}	Feedback terminal voltage ⁽¹⁾	$0\text{ A} \leq I_{\text{OUT}} \leq 3\text{ A}$, $1.5\text{ V} \leq V_{\text{IN}} \leq 7\text{ V}$	0.594	0.605	0.616	V
V_{OUT}	Output voltage range		0.8		V_{IN}	V
	Output voltage accuracy ⁽¹⁾	$0\text{ A} \leq I_{\text{OUT}} \leq 3\text{ A}$, $1.5\text{ V} \leq V_{\text{IN}} \leq 7\text{ V}$, $V_{\text{OUT}} = 0.8\text{ V}, 1.2\text{ V}, 1.8\text{ V}, 6.65\text{ V}$	-2%		2%	
$\frac{\Delta V_{\text{OUT}}\%}{\Delta V_{\text{IN}}}$	Line regulation	$1.5\text{ V} \leq V_{\text{IN}} \leq 7\text{ V}$	-0.07	0.01	0.07	%/V
$\frac{\Delta V_{\text{OUT}}\%}{\Delta I_{\text{OUT}}}$	Load regulation	$0.8\text{ V} \leq V_{\text{OUT}} \leq 6.65\text{ V}$, $0 \leq I_{\text{Load}} \leq 3\text{ A}$		0.08		%/A
ΔV_{OUT}	DC input line regulation	$1.5\text{ V} \leq V_{\text{IN}} \leq 7\text{ V}$, $V_{\text{OUT}} = 0.8\text{ V}, 1.2\text{ V}, 1.8\text{ V}$, $I_{\text{OUT}} = 10\text{ mA}$, $T_{\text{J}} = -55^{\circ}\text{C}$ ⁽²⁾		0.5	3	mV
		$1.5\text{ V} \leq V_{\text{IN}} \leq 7\text{ V}$, $V_{\text{OUT}} = 0.8\text{ V}, 1.2\text{ V}, 1.8\text{ V}$, $I_{\text{OUT}} = 10\text{ mA}$, $T_{\text{J}} = 25^{\circ}\text{C}$ ⁽²⁾		0.2	0.6	
		$1.5\text{ V} \leq V_{\text{IN}} \leq 7\text{ V}$, $V_{\text{OUT}} = 0.8\text{ V}, 1.2\text{ V}, 1.8\text{ V}$, $I_{\text{OUT}} = 10\text{ mA}$, $T_{\text{J}} = 125^{\circ}\text{C}$ ⁽²⁾		0.2	1	

6.5 Electrical Characteristics (continued)

$1.5\text{ V} \leq V_{IN} \leq 7\text{ V}$, $V_{OUT(\text{target})} = V_{IN} - 0.35\text{ V}$, $I_{OUT} = 10\text{ mA}$, $V_{EN} = 1.1\text{ V}$, $C_{OUT} = 22\text{ }\mu\text{F}$, PG terminal pulled up to V_{IN} with $50\text{ k}\Omega$, over operating temperature range ($T_J = -55^\circ\text{C}$ to 125°C), unless otherwise noted. Typical values are at $T_J = 25^\circ\text{C}$.

PARAMETER	TEST CONDITIONS	MIN	TYP	MAX	UNIT	
ΔV_O	DC output load regulation ⁽³⁾	$V_{OUT} = 0.8\text{ V}$, $0 \leq I_{Load} \leq 1\text{ A}$, $T_J = -55^\circ\text{C}$ ⁽²⁾		0.4	1	mV
		$V_{OUT} = 0.8\text{ V}$, $0 \leq I_{Load} \leq 1\text{ A}$, $T_J = 25^\circ\text{C}$ ⁽²⁾		0.6	1.1	
		$V_{OUT} = 0.8\text{ V}$, $0 \leq I_{Load} \leq 1\text{ A}$, $T_J = 125^\circ\text{C}$ ⁽²⁾		0.8	1.3	
		$V_{OUT} = 0.8\text{ V}$, $0 \leq I_{Load} \leq 2\text{ A}$, $T_J = -55^\circ\text{C}$ ⁽²⁾		0.8	1.8	
		$V_{OUT} = 0.8\text{ V}$, $0 \leq I_{Load} \leq 2\text{ A}$, $T_J = 25^\circ\text{C}$ ⁽²⁾		1.3	1.8	
		$V_{OUT} = 0.8\text{ V}$, $0 \leq I_{Load} \leq 2\text{ A}$, $T_J = 125^\circ\text{C}$ ⁽²⁾		1.6	2.4	
		$V_{OUT} = 0.8\text{ V}$, $0 \leq I_{Load} \leq 3\text{ A}$, $T_J = -55^\circ\text{C}$ ⁽²⁾		1.1	1.9	
		$V_{OUT} = 0.8\text{ V}$, $0 \leq I_{Load} \leq 3\text{ A}$, $T_J = 25^\circ\text{C}$ ⁽²⁾		1.9	2.6	
		$V_{OUT} = 0.8\text{ V}$, $0 \leq I_{Load} \leq 3\text{ A}$, $T_J = 125^\circ\text{C}$ ⁽²⁾		2.5	3.4	
		$V_{OUT} = 1.2\text{ V}$, $0 \leq I_{Load} \leq 1\text{ A}$, $T_J = -55^\circ\text{C}$ ⁽²⁾		0.3	1.2	
		$V_{OUT} = 1.2\text{ V}$, $0 \leq I_{Load} \leq 1\text{ A}$, $T_J = 25^\circ\text{C}$ ⁽²⁾		0.5	1.3	
		$V_{OUT} = 1.2\text{ V}$, $0 \leq I_{Load} \leq 1\text{ A}$, $T_J = 125^\circ\text{C}$ ⁽²⁾		0.6	1.3	
		$V_{OUT} = 1.2\text{ V}$, $0 \leq I_{Load} \leq 2\text{ A}$, $T_J = -55^\circ\text{C}$ ⁽²⁾		0.8	1.6	
		$V_{OUT} = 1.2\text{ V}$, $0 \leq I_{Load} \leq 2\text{ A}$, $T_J = 25^\circ\text{C}$ ⁽²⁾		1.1	2.1	
		$V_{OUT} = 1.2\text{ V}$, $0 \leq I_{Load} \leq 2\text{ A}$, $T_J = 125^\circ\text{C}$ ⁽²⁾		1.5	2.1	
		$V_{OUT} = 1.2\text{ V}$, $0 \leq I_{Load} \leq 3\text{ A}$, $T_J = -55^\circ\text{C}$ ⁽²⁾		1	1.7	
		$V_{OUT} = 1.2\text{ V}$, $0 \leq I_{Load} \leq 3\text{ A}$, $T_J = 25^\circ\text{C}$ ⁽²⁾		1.1	2.4	
		$V_{OUT} = 1.2\text{ V}$, $0 \leq I_{Load} \leq 3\text{ A}$, $T_J = 125^\circ\text{C}$ ⁽²⁾		2.2	3.5	
		$V_{OUT} = 1.8\text{ V}$, $0 \leq I_{Load} \leq 1\text{ A}$, $T_J = -55^\circ\text{C}$ ⁽²⁾		0.1	0.9	
		$V_{OUT} = 1.8\text{ V}$, $0 \leq I_{Load} \leq 1\text{ A}$, $T_J = 25^\circ\text{C}$ ⁽²⁾		0.3	0.9	
		$V_{OUT} = 1.8\text{ V}$, $0 \leq I_{Load} \leq 1\text{ A}$, $T_J = 125^\circ\text{C}$ ⁽²⁾		0.4	1.2	
		$V_{OUT} = 1.8\text{ V}$, $0 \leq I_{Load} \leq 2\text{ A}$, $T_J = -55^\circ\text{C}$ ⁽²⁾		1.4	2.4	
		$V_{OUT} = 1.8\text{ V}$, $0 \leq I_{Load} \leq 2\text{ A}$, $T_J = 25^\circ\text{C}$ ⁽²⁾		0.7	1.4	
		$V_{OUT} = 1.8\text{ V}$, $0 \leq I_{Load} \leq 2\text{ A}$, $T_J = 125^\circ\text{C}$ ⁽²⁾		0.6	1.9	
		$V_{OUT} = 1.8\text{ V}$, $0 \leq I_{Load} \leq 3\text{ A}$, $T_J = -55^\circ\text{C}$ ⁽²⁾		2.5	3.9	
		$V_{OUT} = 1.8\text{ V}$, $0 \leq I_{Load} \leq 3\text{ A}$, $T_J = 25^\circ\text{C}$ ⁽²⁾		1.2	2.1	
		$V_{OUT} = 1.8\text{ V}$, $0 \leq I_{Load} \leq 3\text{ A}$, $T_J = 125^\circ\text{C}$ ⁽²⁾		1.2	2.5	
		$V_{OUT} = 6.65\text{ V}$, $0 \leq I_{Load} \leq 1\text{ A}$, $T_J = -55^\circ\text{C}$ ⁽²⁾		1.5	2.9	
		$V_{OUT} = 6.65\text{ V}$, $0 \leq I_{Load} \leq 1\text{ A}$, $T_J = 25^\circ\text{C}$ ⁽²⁾		0.4	2.6	
		$V_{OUT} = 6.65\text{ V}$, $0 \leq I_{Load} \leq 1\text{ A}$, $T_J = 125^\circ\text{C}$ ⁽²⁾		2.8	3.5	
		$V_{OUT} = 6.65\text{ V}$, $0 \leq I_{Load} \leq 2\text{ A}$, $T_J = -55^\circ\text{C}$ ⁽²⁾		3.5	5.9	
		$V_{OUT} = 6.65\text{ V}$, $0 \leq I_{Load} \leq 2\text{ A}$, $T_J = 25^\circ\text{C}$ ⁽²⁾		1.1	4.7	
		$V_{OUT} = 6.65\text{ V}$, $0 \leq I_{Load} \leq 2\text{ A}$, $T_J = 125^\circ\text{C}$ ⁽²⁾		5.8	8	
$V_{OUT} = 6.65\text{ V}$, $0 \leq I_{Load} \leq 3\text{ A}$, $T_J = -55^\circ\text{C}$ ⁽²⁾		5.6	9.3			
$V_{OUT} = 6.65\text{ V}$, $0 \leq I_{Load} \leq 3\text{ A}$, $T_J = 25^\circ\text{C}$ ⁽²⁾		3.7	8			
$V_{OUT} = 6.65\text{ V}$, $0 \leq I_{Load} \leq 3\text{ A}$, $T_J = 125^\circ\text{C}$ ⁽²⁾		13	25			
V_{DO}	Dropout voltage ⁽³⁾	$I_{OUT} = 3\text{ A}$, $V_{OUT} = 1.3\text{ V}$, $V_{IN} = V_{OUT} + V_{DO}$		210	335	mV
I_{CL}	Programmable output current limit range	$V_{IN} = 1.5\text{ V}$, $V_{OUT} = 1.2\text{ V}$, PCL resistance = $47\text{ k}\Omega$		500	750	mA
		$V_{IN} = 1.5\text{ V}$, $V_{OUT} = 1.2\text{ V}$, PCL resistance varies		200	3500 ⁽⁴⁾	
V_{CS}	Operating voltage range at CS (see Section 7) ⁽⁵⁾			0	V_{IN}	V

6.5 Electrical Characteristics (continued)

$1.5\text{ V} \leq V_{IN} \leq 7\text{ V}$, $V_{OUT(\text{target})} = V_{IN} - 0.35\text{ V}$, $I_{OUT} = 10\text{ mA}$, $V_{EN} = 1.1\text{ V}$, $C_{OUT} = 22\text{ }\mu\text{F}$, PG terminal pulled up to V_{IN} with $50\text{ k}\Omega$, over operating temperature range ($T_J = -55^\circ\text{C}$ to 125°C), unless otherwise noted. Typical values are at $T_J = 25^\circ\text{C}$.

PARAMETER		TEST CONDITIONS	MIN	TYP	MAX	UNIT
CSR	Current sense ratio	I_{LOAD} / I_{CS} , $V_{IN} = 2.3\text{ V}$, $V_{OUT} = 1.9\text{ V}$, $T_J = -55^\circ\text{C}$, $I_{LOAD} \geq 500\text{ mA}$	45000	55500	65000	A/A
		I_{LOAD} / I_{CS} , $V_{IN} = 2.3\text{ V}$, $V_{OUT} = 1.9\text{ V}$, $T_J = 25^\circ\text{C}$, $I_{LOAD} \geq 500\text{ mA}$	45000	52000	59000	
		I_{LOAD} / I_{CS} , $V_{IN} = 2.3\text{ V}$, $V_{OUT} = 1.9\text{ V}$, $T_J = 125^\circ\text{C}$, $I_{LOAD} \geq 500\text{ mA}$	45000	51000	56000	
I_{GND}	GND terminal current	$V_{IN} = 1.5\text{ V}$, $V_{OUT} = 1.2\text{ V}$, $I_{OUT} = 2\text{ A}$		10	16	mA
I_Q	Quiescent current (no load)	$V_{IN} = V_{OUT} + 0.5\text{ V}$, $I_{OUT} = 0\text{ A}$		7	10	mA
I_{SHDN}	Shutdown current	$1.5\text{ V} \leq V_{IN} \leq 7\text{ V}$, pre and post 100 krad(Si), $T_J = 25^\circ\text{C}$ ⁽⁶⁾		26	230	μA
I_{SNS} , I_{FB}	FB/SNS terminal current	$V_{IN} = 7\text{ V}$, $V_{OUT} = 6.65\text{ V}$		1	5	nA
I_{EN}	EN terminal input current	$V_{IN} = 7\text{ V}$, $V_{EN} = 7\text{ V}$, $V_{OUT} = 6.65\text{ V}$		20	150	nA
V_{ILEN}	EN terminal input low (disable)	$1.5\text{ V} < V_{IN} < 7\text{ V}$			0.55	V
V_{IHEN}	EN terminal input high (enable)	$1.5\text{ V} < V_{IN} < 7\text{ V}$	$V_{IN} - 0.7$			V
Eprop Dly	Enable terminal propagation delay	$V_{IN} = 2.2\text{ V}$, EN rise to $I_{OUT\text{rise}}$		650	1000	μs
T_{EN}	Enable terminal turn-on delay (delay to PG assertion)	$V_{IN} = 2.2\text{ V}$, $V_{OUT} = 1.8\text{ V}$, $I_{LOAD} = 1\text{ A}$, $C_{OUT} = 220\text{ }\mu\text{F}$, $C_{SS} = 2\text{ nF}$		1.4	1.6	ms
V_{THPG}	PG threshold	No load, $0.8\text{ V} \leq V_{OUT} \leq 6.65\text{ V}$	86%	90%		
$V_{THPGHYS}$	PG hysteresis	$1.5\text{ V} \leq V_{IN} \leq 7\text{ V}$		2%		
$V_{OL\text{ PG}}$	PG terminal output low	$I_{PG} = 0\text{ mA}$ to -1 mA		120	300	mV
I_{LKPG}	PG terminal leakage current	$V_{OUT} > V_{THPG}$, $V_{PG} = 1.2\text{ V}$		0.2	1.5	μA
		$V_{OUT} > V_{THPG}$, $V_{PG} = 7\text{ V}$		0.5	2.5	
I_{SS}	SS terminal charge current	$V_{IN} = 1.5\text{ V}$ to 7 V		2.5	3.5	μA
$I_{SS\text{disb}}$	SS terminal disable current	$V_{IN} = 1.5\text{ V}$ to 7 V		5	10	μA
V_{SS}	SS terminal voltage (device enabled) ⁽⁷⁾	$V_{IN} = 1.5\text{ V}$ to 7 V			1.232	V
$V_{SS\text{disb}}$	SS terminal low-level input voltage to disable device	$V_{IN} = 1.5\text{ V}$ to 7 V			0.4	V
PSRR	Power-supply rejection ratio	$V_{IN} = 2.5\text{ V}$, $V_{OUT} = 1.8\text{ V}$, $C_{OUT} = 220\text{ }\mu\text{F}$	1 kHz	48		dB
			100 kHz	25		
V_N	Output noise voltage	BW = 10 Hz to 100 kHz, $I_{OUT} = 3\text{ A}$, $V_{IN} = 2\text{ V}$, $V_{OUT} = 1.8\text{ V}$		20.33		μV_{RMS}
TSD	Thermal shutdown temperature			185		$^\circ\text{C}$

- (1) The output voltage accuracy of condition at $I_{OUT} = 2\text{ A}$ and $I_{OUT} = 3\text{ A}$ is specified by characterization, but not production tested.
- (2) Line and load regulations done under pulse condition for $t < 10\text{ ms}$.
- (3) The parameter is specified to the limit in characterization, but not production tested.
- (4) The maximum limit of the I_{CL} parameter is specified to the limit in characterization, but not production tested.
- (5) To insure foldback is enabled, V_{CS} must be $> 0.9 \cdot V_{FB}$.
- (6) This maximum limit applies to SMD 5962R13202 post 100-krad(Si) test at 25°C .
- (7) Any external pullup voltage should not exceed 1.188 V .

6.6 Typical Characteristics

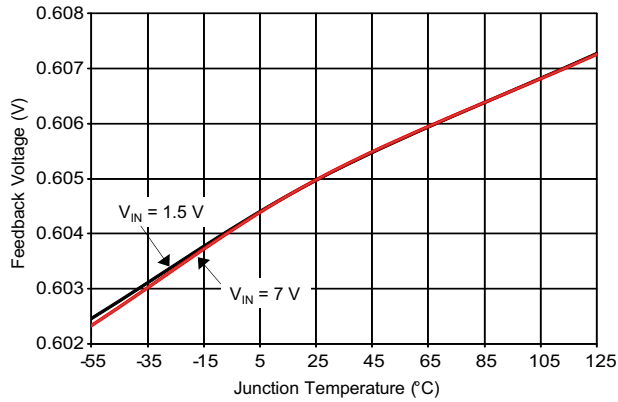

Figure 6-1. Feedback Voltage vs Temperature

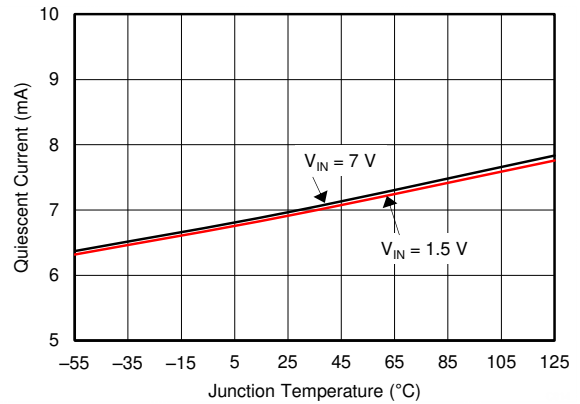

Figure 6-2. Quiescent Current vs Temperature

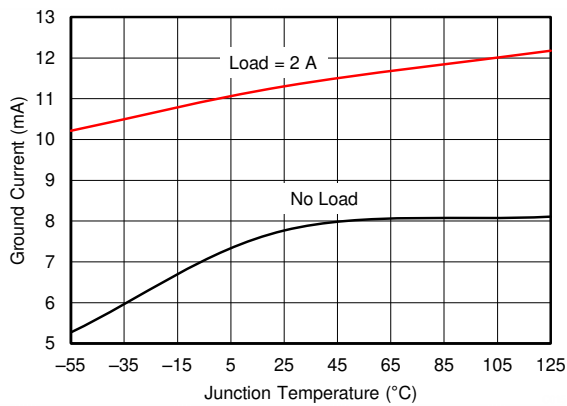

Figure 6-3. Ground Current vs Temperature

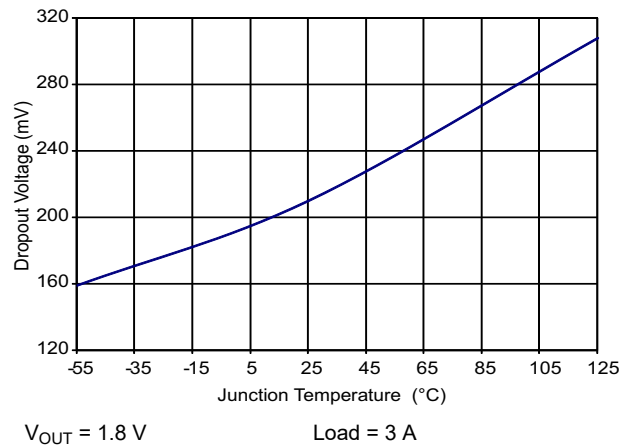

Figure 6-4. Dropout Voltage vs Temperature

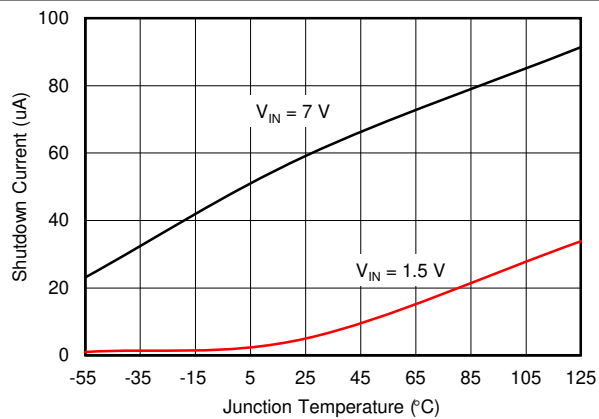

Figure 6-5. Shutdown Current vs Temperature

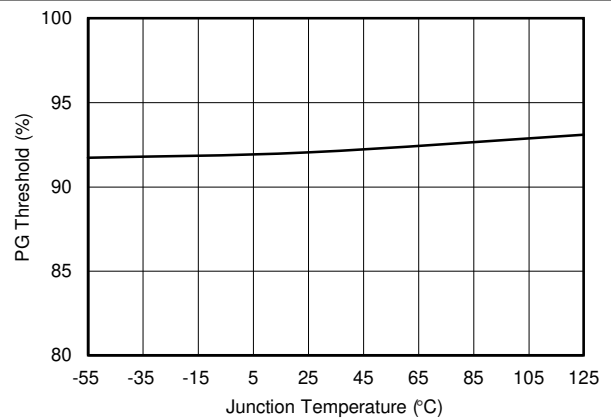

Figure 6-6. PG Threshold vs Temperature

7 Detailed Description

7.1 Overview

The TPS7H1101A-SP is 3-A, 1.5-V to 7-V LDO linear regulator that uses PMOS pass element configuration.

It uses TI's proprietary process to achieve low noise, high PSRR combined with high-thermal performance in a 16-pin ceramic flatpack package (HKR).

A number of features are incorporated in the design to provide high reliability and system flexibility. Current foldback, current limit, and thermal protection are incorporated in the design to make it viable for space environments.

The device also has a current sense monitoring feature. A resistor connected from the current sense (CS) terminal to VIN indicates voltage proportional to the output current. [Section 8.2.1.3](#) provides a detailed description of this feature. When CS is pulled high to voltage greater than 90% Vref (0.544 V), foldback current limit is enabled. Pulling CS below 0.544 V disables the foldback current limit.

A resistor connected from the programmable current limit (PCL) terminal to ground sets the overcurrent limit activation point. When overcurrent limit activation point is reached, it results in the LDO going into current foldback mode. Output current is reduced to approximately 50% of the current limit set point. [Section 8.2.1.2](#) provides a detailed description of this feature.

TPS7H1101A-SP incorporates thermal protection, which disables the output when the junction temperature rises to approximately 185°C, allowing the device to cool. Cycling limits the dissipation of the regulator, protecting it from catastrophic damage as a result of overheating.

To provide system flexibility for demanding current needs, the LDO can be configured in parallel operation as indicated in [Figure 8-12](#). [Section 8.2.1.6](#) provides detailed parallel operation information.

An enable feature is incorporated in the design allowing the user to enable or disable the LDO. Power Good (PG), is an open-drain connection, indicating status of the output voltage regulation. These provide the customers system flexibility in monitoring and controlling the LDO operation.

7.2 Functional Block Diagram

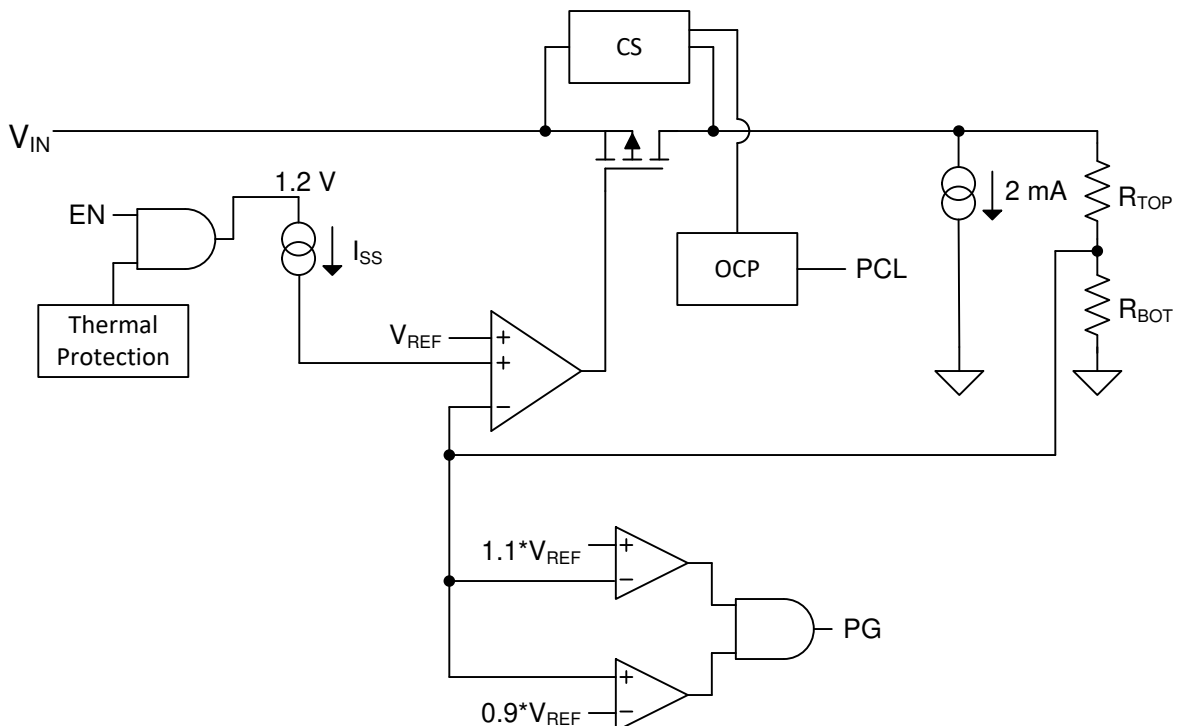

7.3 Feature Description

7.3.1 Soft Start

Connecting a capacitor (C_{SS}) from the SS terminal to GND slows down the output voltage ramp rate. The soft-start capacitor charges up to 1.2 V, with a threshold of V_{FB} .

$$C_{SS} = \frac{t_{SS} \cdot I_{SS}}{V_{FB}} \quad (1)$$

where

- t_{SS} = soft-start time
- $I_{SS} = 2.5 \mu\text{A}$
- $V_{FB} = V_{REF} = 0.605 \text{ V}$

7.3.2 Power Good (PG)

Power Good terminal (9) is an open-drain connection and can be used to sequence multiple LDOs. [Figure 7-1](#) shows typical connection. The PG terminal will be pulled low until the output voltage reaches 90% of its maximum level. At that point, the PG pin will be pulled up. Since the PG pin is open drain, it can be pulled up to any voltage as long as it does not exceed the absolute max of 7.5 V listed in [Section 6.5](#).

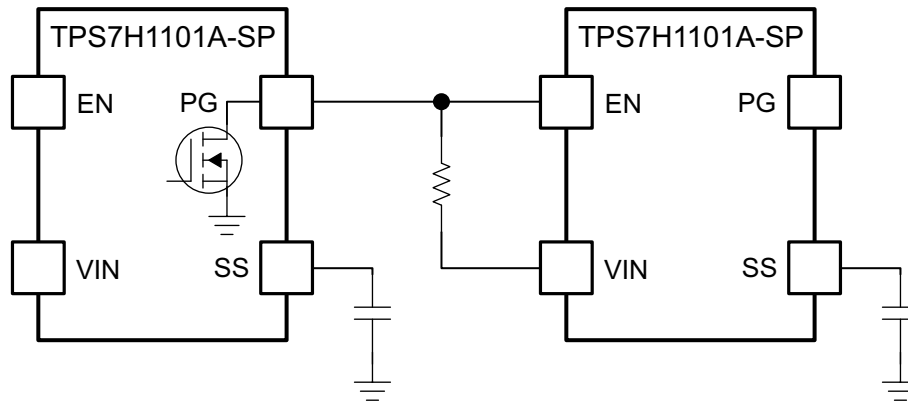

Copyright © 2017, Texas Instruments Incorporated

Figure 7-1. Sequencing LDOs With Power Good

Note

For PSpice models, WEBENCH, and reference design, see the [Design & development](#) tab of the product folder.

1. PSpice transient model (switching, transient, and stability simulations)
2. PSpice Worst Case Analysis (WCA) model (radiation and aging stability – Bode plot)

7.4 Device Functional Modes

7.4.1 Enable/Disable

For V_{IN} from 1.5 V to 7 V, TPS7H1101A-SP can be disabled by pulling the enable terminal to logic low at a minimum of 0.7 V. Enable cannot exceed V_{IN} by more than 0.3 V, and in most cases, the enable terminal is connected to V_{IN} .

8 Application and Implementation

Note

Information in the following applications sections is not part of the TI component specification, and TI does not warrant its accuracy or completeness. TI's customers are responsible for determining suitability of components for their purposes, as well as validating and testing their design implementation to confirm system functionality.

8.1 Application Information

The TPS7H1101A-SP LDO linear regulator is targeted space environment applications. This regulator has various features such as low dropout, soft start, output current foldback, high-side current sensing (where sensing voltage at CS pin provides voltage proportional to output current), and current sharing.

8.1.1 Stability

Bode plots are a standard approach in assessing stability. This approach requires a single feedback path where an AC signal is injected across a resistor (typically 50 Ω) and measurements are taken on either side of the resistor as shown in Figure 8-1. From this measurement, loop gain and phase plots can be generated. Crossover frequency, f_C , is defined as the frequency where the magnitude of the loop gain is unity and phase margin is evaluated at the crossover frequency f_C .

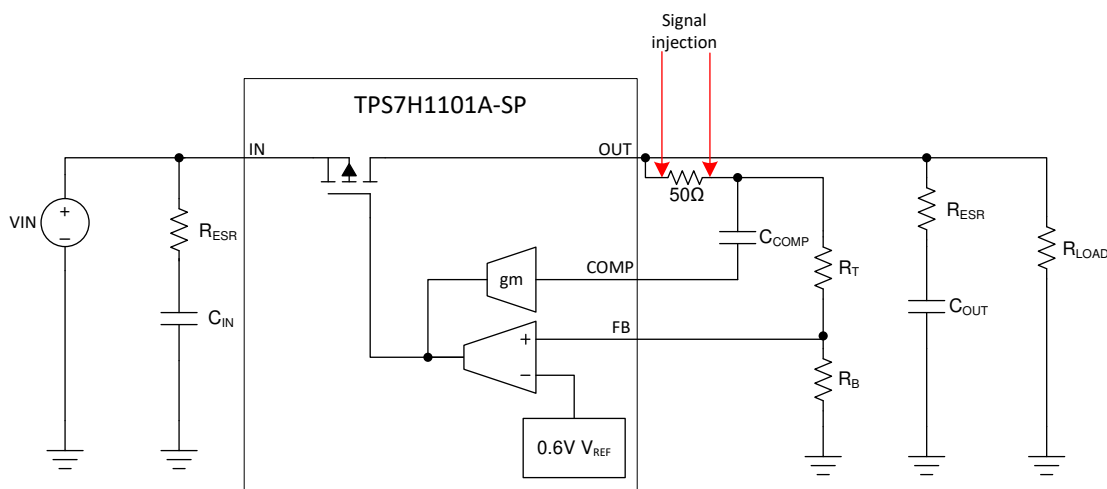
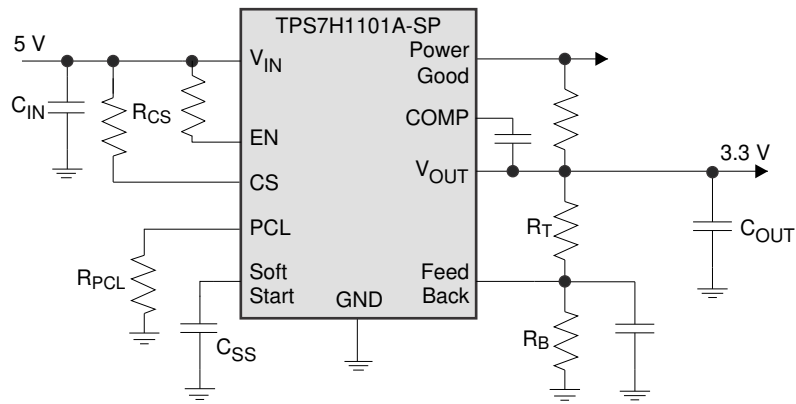

Figure 8-1. Conventional Bode Plot With Simplified Feedback Loops

However, it is important the AC signal is injected as shown in Figure 8-1. This injection point ensures that the feedback signal goes through both the outer loop (consisting of the top feedback resistor, R_T) and the inner loop (consisting of the compensation capacitor, C_{COMP}). If the only the outer loop is measured, the resulting crossover frequency will be lower which would indicate a poorer transient response than reality. Therefore, it is best to inject the measurement signal at a point where it goes through both loops. If this is not possible, the two loops may be measured independently and added using the superposition principle.

Furthermore, the stability of the device can be qualitatively validated by applying a step load to the output and observing the response. The SPICE models for the device can be found on the [TPS7H1101A-SP](#) product page. To simulate impedance measurements, the transient model should be used.

8.2 Typical Application



Copyright © 2017, Texas Instruments Incorporated

Figure 8-2. Typical Application Circuit

8.2.1 Detailed Design Procedure

8.2.1.1 Adjustable Output Voltage (Feedback Circuit)

The output voltage of the TPS7H1101A-SP can be set to a user-programmable level between 0.8 V and 6.65 V. Achieve this by using a resistor divider connected between V_{OUT} , FB, and GND terminals. R_{TOP} connected between V_{OUT} and V_{FB} , and R_{BOTTOM} connected between V_{FB} and GND.

Use Equation 2 to determine V_{OUT} .

$$V_{OUT} = \frac{(R_{TOP} + R_{BOTTOM}) \cdot V_{FB}}{R_{BOTTOM}} \quad (2)$$

where

- $V_{FB} = 0.605 \text{ V}$

Table 8-1. Example Resistor Values for Typical Voltages

V_{OUT}	Standard 1% Resistors		Standard 0.1% Resistors	
	R_{TOP}	R_{BOTTOM}	R_{TOP}	R_{BOTTOM}
0.8 V	10.7 k Ω	33.2 k Ω	10.7 k Ω	33.2 k Ω
1 V	13.7 k Ω	21 k Ω	12.6 k Ω	19.3 k Ω
1.2 V	11.3 k Ω	11.5 k Ω	11.8 k Ω	12 k Ω
1.5 V	15.8 k Ω	10.7 k Ω	18.2 k Ω	12.3 k Ω
1.8 V	23.2 k Ω	11.8 k Ω	32 k Ω	16.2 k Ω
2.5 V	10.7 k Ω	3.4 k Ω	37.9 k Ω	12.1 k Ω
3.3 V	51.1 k Ω	11.5 k Ω	10.2 k Ω	2.29 k Ω
4 V	13.3 k Ω	2.37 k Ω	31.2 k Ω	5.56 k Ω
5 V	11.5 k Ω	1.58 k Ω	16.2 k Ω	2.23 k Ω
5.5 V	17.4 k Ω	2.15 k Ω	89.8 k Ω	11.1 k Ω
6 V	90.9 k Ω	10.2 k Ω	10.7 k Ω	1.2 k Ω
6.5 V	26.7 k Ω	2.74 k Ω	15.2 k Ω	1.56 k Ω
6.6 V	11.3 k Ω	1.15 k Ω	22.1 k Ω	2.23 k Ω
6.7 V	39.2 k Ω	3.92 k Ω	13.8 k Ω	1.37 k Ω

8.2.1.2 PCL

PCL resistor, R_{PCL} , sets the overcurrent limit activation point and can be calculated per Equation 3.

$$R_{PCL} = (CSR \times V_{REF}) / (I_{CL} - 0.0403) \quad (3)$$

where

- $V_{REF} = 0.605 \text{ V}$
- I_{CL} = Programmable current limit (A)
- Current sense ratio (CSR) is the ratio of output load current to I_{CS} ; typical value of the CSR is 52000
- Offset value 0.0403 is a fixed offset derived from internal keep-alive biasing

Figure 8-3 shows the output load current (I_{LOAD}) versus PCL terminal current (I_{PCL}) varied with minimum and maximum range of CSR values by temperature. The R_{PCL} resistor should be chosen to set the worst case I_{LOAD} across system normal operating load and temperature range without reaching overcurrent activation point of $I_{PCL} \cdot R_{PCL} \geq V_{REF}$.

Additionally, a suitable resistor R_{CS} must be chosen to ensure the CS terminal is within its operating range of 0.3 V to V_{IN} and V_{CS} needs to be greater than $0.9 \cdot V_{REF}$ (0.544 V) to insure foldback remains enabled when current activation point is triggered.

The maximum PCL is 3.5 A. The range of resistor that can be used on the PCL terminal to GND is 8.2 kΩ to 160 kΩ. It is not recommended to use overcurrent limit activation thresholds of less than 500 mA due to internal bias offset currents representing a larger percentage of total I_{PCL} current and therefore additional error.

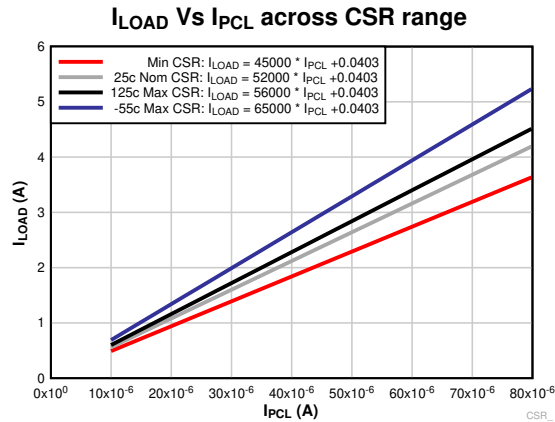

Figure 8-3. I_{LOAD} (A) vs I_{PCL} (A)

8.2.1.3 High-Side Current Sense

Figure 8-4 shows the cascode NMOS current mirror. V_{CS} must be ≥ 0.3 V for proper biasing. Additionally V_{CS} must be greater than 0.9 · V_{REF} (0.544 V) if foldback current limiting is intended to be enabled. The following example shows the typical calculation of R_{CS}.

$$I_{CS} = \frac{I_{LOAD} + I_{offset}}{CSR} \quad (4)$$

$$R_{CS} = \frac{V_{IN} - V_{CS}}{I_{CS}} \quad (5)$$

where

- I_{LOAD} is the output load current
- CSR is the current sense ratio
- I_{offset} is internal keep-alive bias current times CSR
- I_{offset} = 5 μA · CSR

When V_{IN} = 2.3 V, select V_{CS} = 2.05 V, I_{LOAD} = 3 A, CSR = 52000, and I_{offset} = 0.26 A, then I_{CS} = 62.69 μA and R_{CS} = 3.99 kΩ.

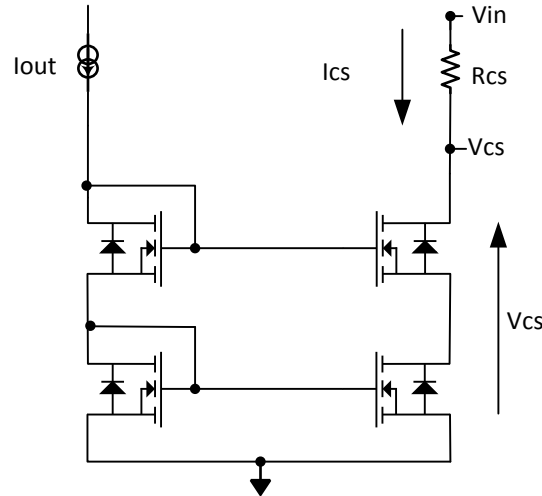
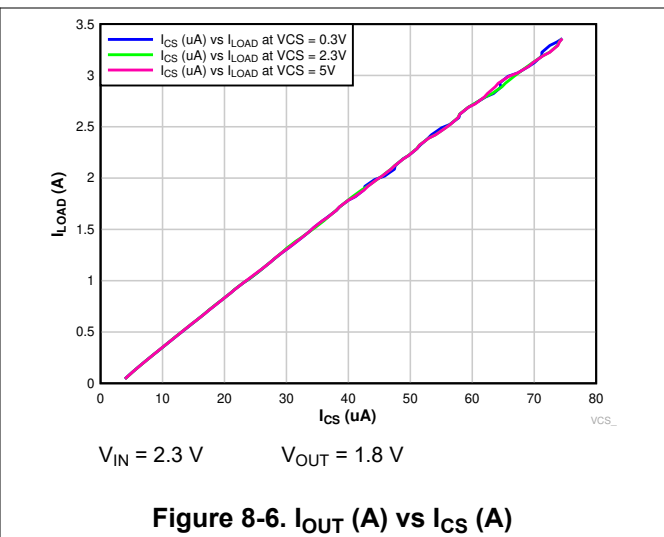
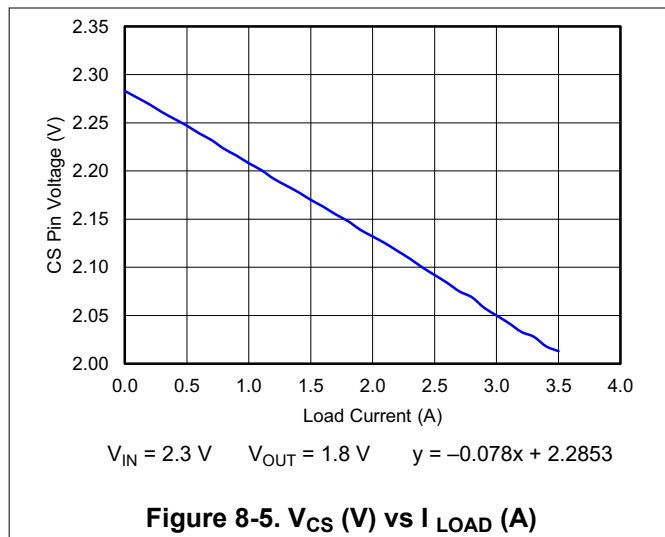

Figure 8-4. Cascode NMOS Current Mirror

For TPS7H1101A-SP, [Figure 8-5](#) shows a typical curve V_{CS} vs I_{OUT} for $V_{IN} = 2.28\text{ V}$ and $R_{CS} = 3.65\text{ k}\Omega$. A resistor connected from the CS terminal to V_{IN} indicates voltage proportional to the output current.

Monitoring current in the CS terminal (I_{CS} vs I_{LOAD}) indicates the current sense ratio between the main PMOSFET and the current sense MOSFET as shown in [Figure 8-6](#). Additionally [Figure 8-6](#) shows the linearity of the CSR ratio across V_{CS} pin voltage range of 0.3 V to V_{IN} . V_{CS} must be $\geq 0.3\text{-V}$ minimum to keep circuit properly biased.

[Figure 8-7](#) shows I_{LOAD} vs I_{CS} across the full range of CSR values.



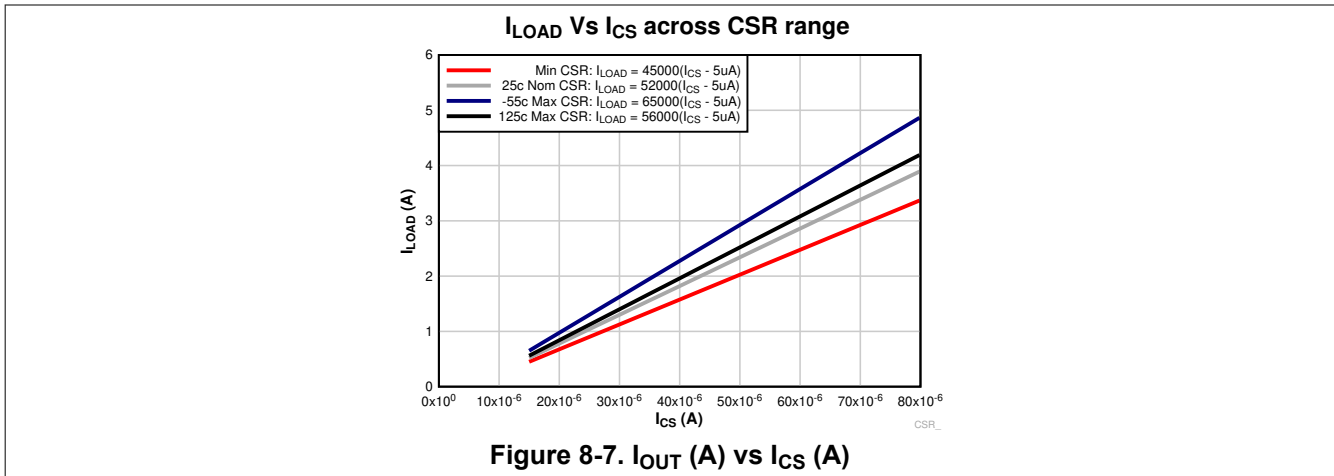

8.2.1.4 Current Foldback

1. The TPS7H1101A-SP has a current foldback feature which can be enabled when the CS terminal is greater than $0.9 \cdot V_{REF}$ (0.544 V). Pulling CS below this threshold disables the foldback current limit. If the foldback current limit is disabled, then the LDO will begin regulating again as soon as the current falls below the clamp threshold.
2. With foldback current limit enabled, when current limit trip point is activated,
 - a. Output voltage drops low, and
 - b. Output current folds back to approximately 50% of the current limit trip point.

This results in minimizing the power loss under fault conditions. Monitoring the voltage at the CS terminal indicates voltage proportional to the output current. It is important to note that the current sense voltage range on CS pin must be designed to stay above the $0.9 \cdot V_{REF}$ threshold to insure foldback is not inadvertently disabled at high currents.

8.2.1.5 Transient Response

Figure 8-8, Figure 8-9, and Figure 8-10 indicate the transient response behavior of the LDO for 50% step load change.

Channel 1: Input voltage

Channel 3: Step load in current

Channel 4: Output voltage overshoot/undershoot

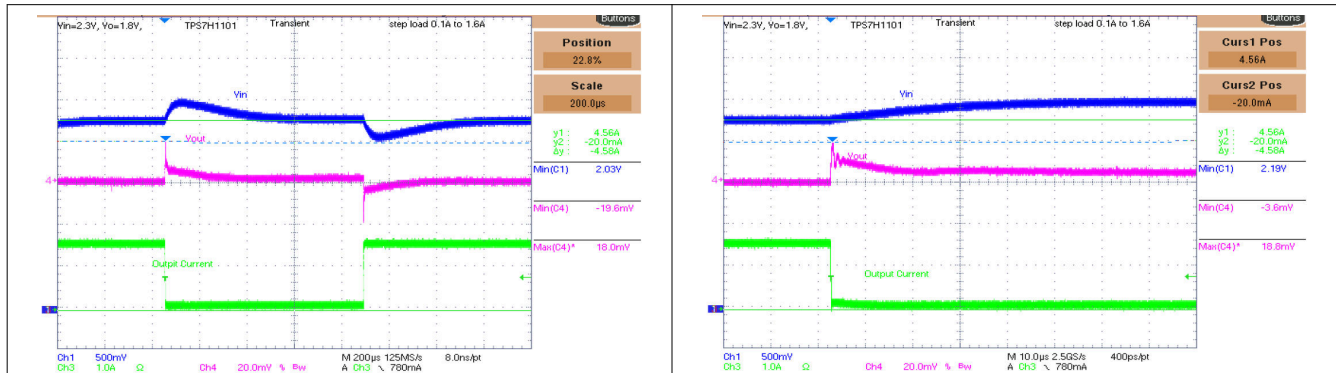

Figure 8-8. Load Transient Response: Step Load 0.1 to 1.6 A, $V_{IN} = 2.3\text{ V}$, $V_{OUT} = 1.8\text{ V}$

Figure 8-9. Expanded View Overshoot

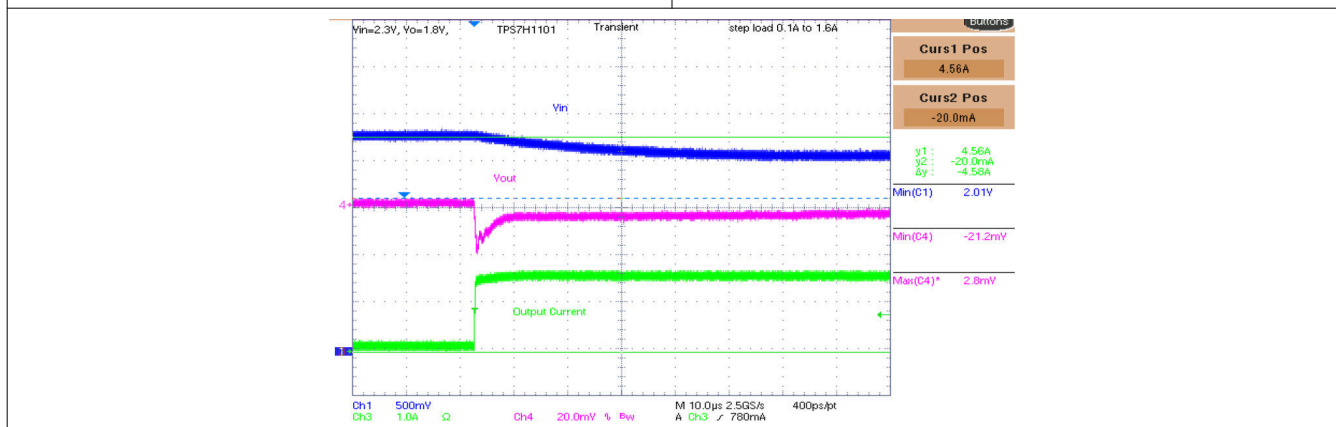

Figure 8-10. Expanded View Undershoot

8.2.1.6 Current Sharing

For demanding load requirements, multiple LDOs can be paralleled as indicated in [Figure 8-12](#). In parallel mode, the CS terminal of LDO1 must be connected to the PCL terminal of LDO2 via a series resistor, R_{CL} , and CS terminal of LDO2 must be connected to PCL terminal of LDO1 via series resistor, R_{CL} . The typical value of R_{CL} in parallel operation is 3.75 k Ω for current limit > 6 A. In parallel configuration, R_{CL} (resistor from PCL to GND) and R_{CS} (resistor from CS terminal to V_{IN}) must be left open (unpopulated). The R_{CL} value must be selected so that the operating condition of the CS terminal is maintained, as specified in [Section 6.5](#). V_{CS} must be greater than 0.3 V to insure proper current sense operation. The current from PCL through R_{CL} of LDO1 is determined by the output load current of LDO2 divided by the CSR. Hence, the voltage at CS terminal of the LDO1 is $0.605\text{ V} - ((\text{output load current of LDO2} + 0.2458) / \text{CSR} \times R_{CL})$.

Alternately, it can also provide twice the output current to meet system needs. When using two LDOs in parallel operation for higher output load current, use POL TPS50601-SP as an input source.

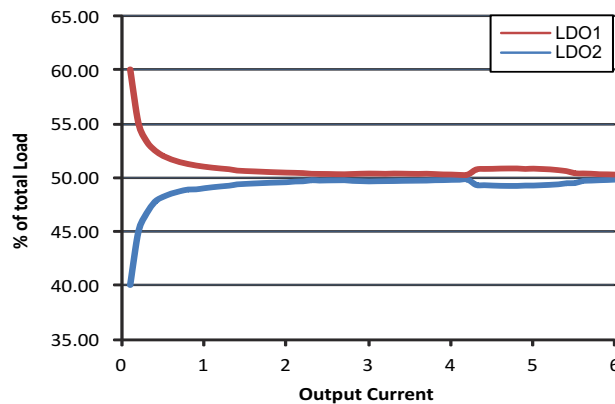

Figure 8-11. LDO Current Share

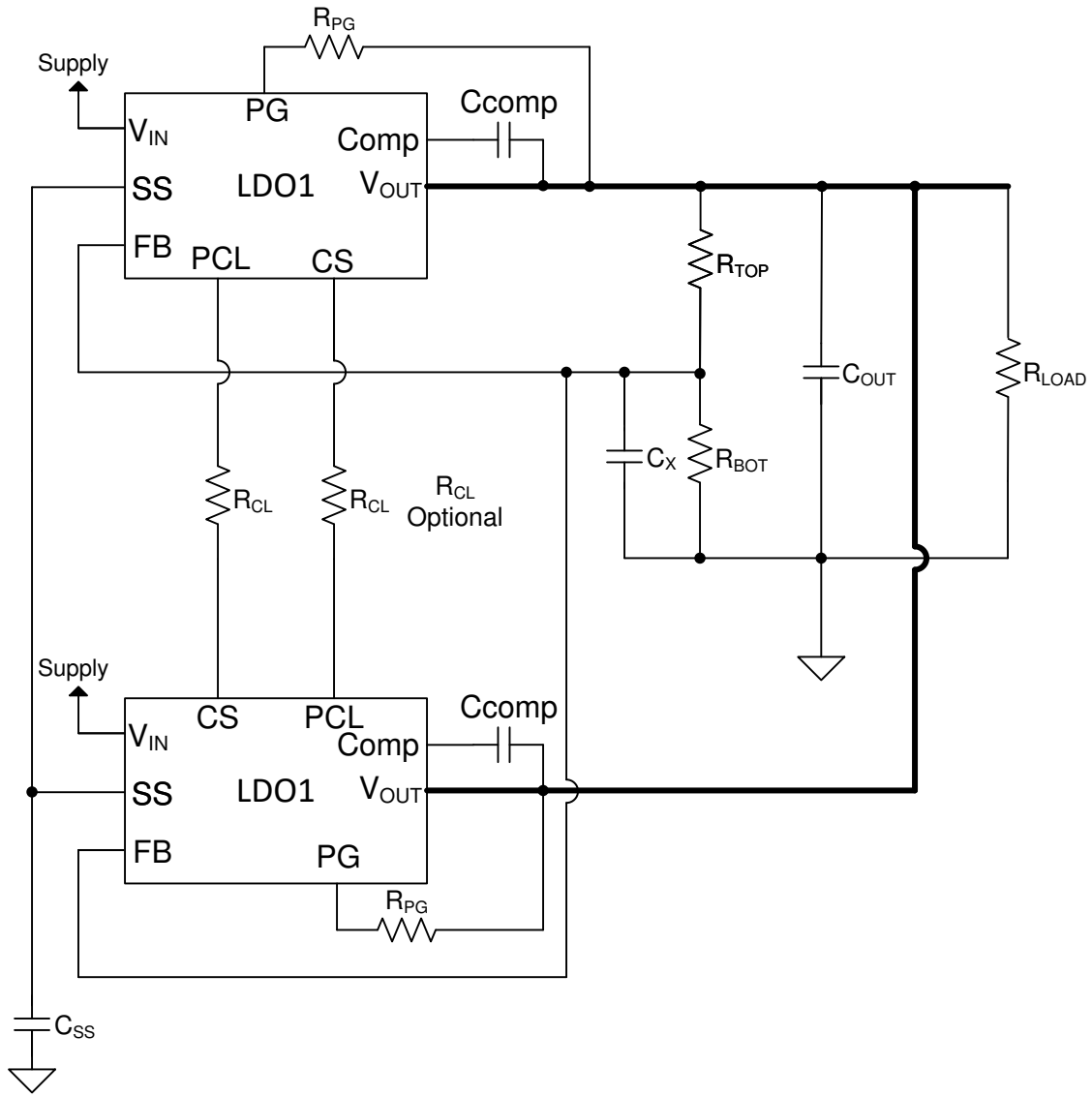

Figure 8-12. Block Diagram (Parallel Operation)

8.2.1.7 Compensation

Figure 8-13 shows a generic block diagram for TPS7H1101A-SP LDO with external compensation components. LDO incorporates nested loops, thus providing the high gain necessary to meet design performance.

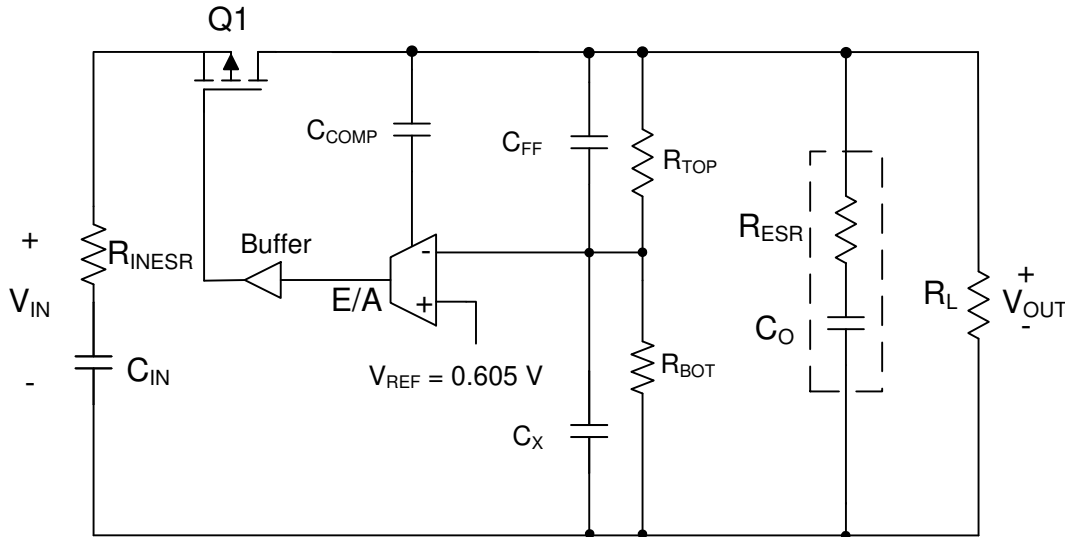

Figure 8-13. TPS7H1101A-SP Compensation

Resistor divider composed of R_{top} and R_{bottom} determine the output voltage set points as indicated by Equation 2.

Output capacitor C_{OUT} introduces a pole and a zero as shown in the following.

$$F_{p_{co}} = \frac{1}{2 \cdot \pi \cdot C_o \cdot R_L} \quad (6)$$

$$F_{z_{co}} = \frac{1}{2 \cdot \pi \cdot C_o \cdot C_{esr}} \quad (7)$$

The TPS7H1101A-SP was designed so that the ESR of the output capacitor will not have a strong influence on the response of the LDO. However, an optional capacitor, C_x , can be added in parallel with the bottom feedback resistor to introduce a pole to cancel $F_{z_{co}}$. Equation 8 shows how to calculate the location of the pole introduced by C_x . To cancel the zero directly, F_p should be equal to $F_{z_{co}}$.

$$F_p = \frac{1}{2 \cdot \pi \cdot C_x \cdot R_{bottom}} \quad (8)$$

C_x is calculated to be 1000 pF for $C_o = 220 \mu\text{F}$, $C_{esr} = 45 \text{ m}\Omega$, and $R_{bottom} = 10 \text{ k}\Omega$.

Figure 8-13 also includes a place holder for a feed forward capacitance C_{ff} . Use of feed forward compensation can be more advantageous than use of C_x . Please reference application note [Pros and Cons of Using a Feedforward Capacitor with a Low-Dropout Regulator](#) for additional information on usage of C_{FF} .

Internal compensation in the LDO cancels the output capacitor pole introduced by C_{OUT} and R_L .

C_{comp} introduces a dominant pole at low frequency. TI recommends that a C_{comp} value of 10 nF.

8.2.1.8 Output Noise

Output noise is measured using an HP3495A. Figure 8-14 and Figure 8-15 show noise of the TPS7H1101A-SP in $\mu\text{V}/\sqrt{\text{Hz}}$ vs frequency.

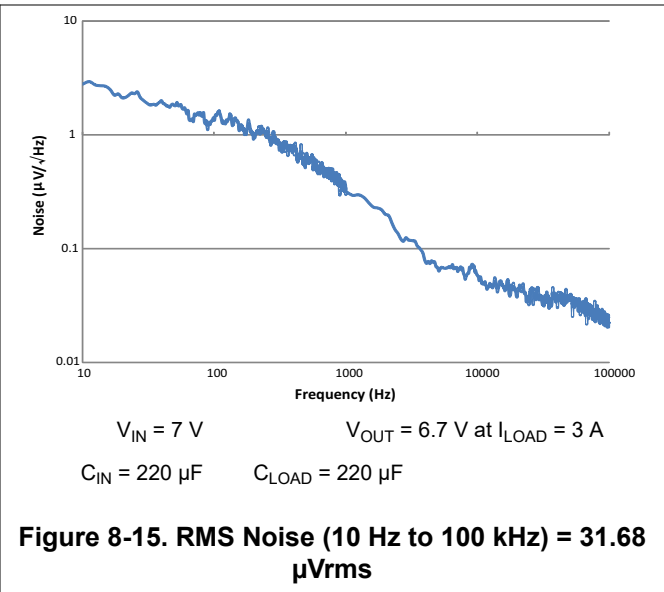
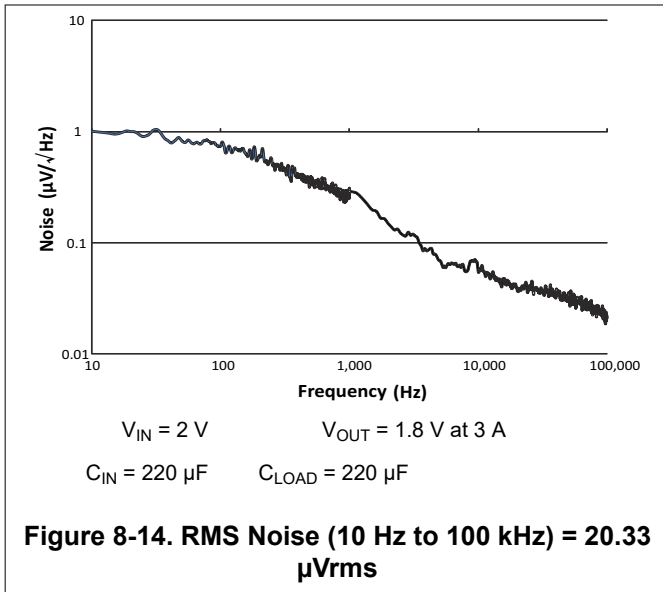

8.2.1.9 Capacitors

TPS7H1101A-SP requires the use of a combination of tantalum and ceramic capacitors to achieve good volume to capacitance ratio. Table 8-2 highlights some of the capacitors used in the device. TI recommends to follow proper derating guidelines as recommended by the capacitor manufacturer based upon output voltage and operating temperature.

Note that polymer-based tantalum capacitors must be derated to at least 60% of rated voltage, whereas manganese oxide (MnO_2) based tantalum capacitors should be derated to 33% of rated voltage depending upon the operating temperature.

TI recommends to use a tantalum capacitor along with a 0.1- μF ceramic capacitor. The device is stable for input and output tantalum capacitor values of 10 μF to 220 μF with the ESR range of 10 m Ω to 2 Ω . However, the dynamic performance of the device varies based on load conditions and the capacitor values used.

TI recommends a minimum output capacitor of 22 μF with ESR of 1 Ω or less to prevent oscillations. X7R dielectrics are preferred. See Table 8-2 for various capacitor recommendations.

Table 8-2. TPS7H1101A-SP Capacitors

CAPACITOR PART NUMBER	CAPACITOR DETAILS (CAPACITOR, VOLTAGE, ESR)	TYPE	VENDOR
T493X107K016CH612A ⁽¹⁾	100 μ F, 16 V, 100 m Ω	Tantalum - MnO2	Kemet
T493X226M025AH6x20 ⁽¹⁾	22 μ F, 25 V, 35 m Ω	Tantalum - MnO2	Kemet
T525D476M016ATE035 ⁽¹⁾	47 μ F, 10 V, 35 m Ω	Tantalum - Polymer	Kemet
T540D476M016AH6520 ⁽¹⁾	47 μ F, 16 V, 20 m Ω	Tantalum - Polymer	Kemet
T525D107M010ATE025 ⁽¹⁾	100 μ F, 10 V, 25 m Ω	Tantalum - Polymer	Kemet
T541X337M010AH6720 ⁽¹⁾	330 μ F, 10 V, 6 m Ω	Tantalum - Polymer	Kemet
T525D227M010ATE025 ⁽¹⁾	220 μ F, 10 V, 25 m Ω	Tantalum - Polymer	Kemet
T495X107K016ATE100 ⁽¹⁾	100 μ F, 16 V, 100 m Ω	Tantalum - MnO2	Kemet
CWR29FK227JTHC ⁽¹⁾	220 μ F, 10 V, 180 m Ω	Tantalum - MnO2	AVX
THJE107K016AJH	100 μ F, 16 V, 58 m Ω	Tantalum	AVX
THJE227K010AJH	220 μ F, 10 V, 40 m Ω	Tantalum	AVX
SMX33C336KAN360	33 μ F, 25 V	Stacked ceramic	AVX
SR2225X7R335K1P5#M123	3.3 μ F, 25 V, 10 m Ω	Ceramic	Presidio Components Inc

(1) Operating temperature is -55°C to 125°C .

8.2.2 Application Curves

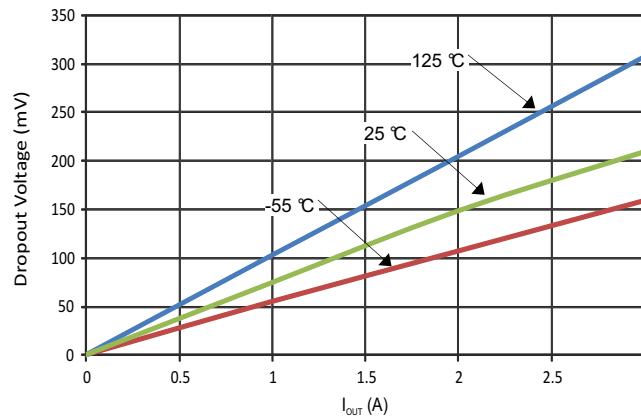

Figure 8-16. VDO vs I_{OUT}

9 Power Supply Recommendations

This device is designed to operate with an input voltage supply up to 7 V. The minimum input voltage should provide adequate headroom greater than the dropout voltage for the device to have a regulated output. If the input supply is noisy, additional input capacitors with low ESR can help improve the output noise performance.

10 Layout

10.1 Layout Guidelines

- For best performance, all traces should be as short as possible, and no longer than 5 cm.
- Use wide traces for IN, OUT and GND to minimize the parasitic electrical effects.
- Place the output capacitors (COUT) as close as possible to the OUT pin of the device.

10.2 Layout Example

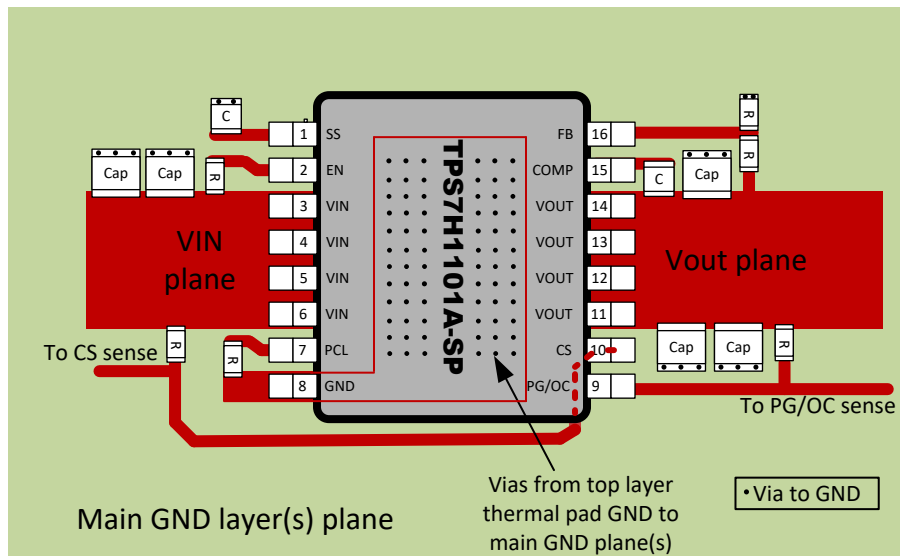

Figure 10-1. PCB Layout Example

11 Device and Documentation Support

11.1 Device Support

11.1.1 Third-Party Products Disclaimer

TI'S PUBLICATION OF INFORMATION REGARDING THIRD-PARTY PRODUCTS OR SERVICES DOES NOT CONSTITUTE AN ENDORSEMENT REGARDING THE SUITABILITY OF SUCH PRODUCTS OR SERVICES OR A WARRANTY, REPRESENTATION OR ENDORSEMENT OF SUCH PRODUCTS OR SERVICES, EITHER ALONE OR IN COMBINATION WITH ANY TI PRODUCT OR SERVICE.

11.1.2 Device Nomenclature

KGD	Known good die
RHA	Radiation hardness assurance for space systems
5962R13202	Same device as TPS50601-SP, shown with standard microcircuit drawing (SMD)
TPS7H1101A-SP	Same device as 5962R10221, shown with TI package drawing

11.2 Documentation Support

11.2.1 Related Documentation

For related documentation see the following:

- Texas Instruments, [Pros and Cons of Using a Feedforward Capacitor with a Low-Dropout Regulator application note](#) (SBVA042)
- Texas Instruments, [TPS7H1101-SP TID and SEE radiation report](#) (SNAA257)

11.3 Receiving Notification of Documentation Updates

To receive notification of documentation updates, navigate to the device product folder on [ti.com](#). Click on *Subscribe to updates* to register and receive a weekly digest of any product information that has changed. For change details, review the revision history included in any revised document.

11.4 Support Resources

[TI E2E™ support forums](#) are an engineer's go-to source for fast, verified answers and design help — straight from the experts. Search existing answers or ask your own question to get the quick design help you need.

Linked content is provided "AS IS" by the respective contributors. They do not constitute TI specifications and do not necessarily reflect TI's views; see TI's [Terms of Use](#).

11.5 Trademarks

TI E2E™ is a trademark of Texas Instruments.
All trademarks are the property of their respective owners.

11.6 Electrostatic Discharge Caution



This integrated circuit can be damaged by ESD. Texas Instruments recommends that all integrated circuits be handled with appropriate precautions. Failure to observe proper handling and installation procedures can cause damage.

ESD damage can range from subtle performance degradation to complete device failure. Precision integrated circuits may be more susceptible to damage because very small parametric changes could cause the device not to meet its published specifications.

11.7 Glossary

[TI Glossary](#) This glossary lists and explains terms, acronyms, and definitions.

12 Mechanical, Packaging, and Orderable Information

The following pages include mechanical, packaging, and orderable information. This information is the most current data available for the designated devices. This data is subject to change without notice and revision of this document. For browser-based versions of this data sheet, refer to the left-hand navigation.

PACKAGING INFORMATION

Orderable part number	Status (1)	Material type (2)	Package Pins	Package qty Carrier	RoHS (3)	Lead finish/ Ball material (4)	MSL rating/ Peak reflow (5)	Op temp (°C)	Part marking (6)
5962R1320202V9A	Active	Production	XCEPT (KGD) 0	70 OTHER	Yes	Call TI	N/A for Pkg Type	-55 to 125	
5962R1320202VXC	Active	Production	CFP (HKR) 16	25 TUBE	ROHS Exempt	NIAU	N/A for Pkg Type	-55 to 125	5962R1320202VXC TPS7H1101-RHA
5962R1320202VXC.A	Active	Production	CFP (HKR) 16	25 TUBE	ROHS Exempt	NIAU	N/A for Pkg Type	-55 to 125	5962R1320202VXC TPS7H1101-RHA
TPS7H1101AHKR/EM	Active	Production	CFP (HKR) 16	25 TUBE	ROHS Exempt	NIAU	N/A for Pkg Type	25 to 25	TPS7H1101AHKR/EM EVAL ONLY
TPS7H1101AY/EM	Active	Production	XCEPT (KGD) 0	5 OTHER	Yes	Call TI	N/A for Pkg Type	25 to 25	
TPS7H1101HKR/EM	Active	Production	CFP (HKR) 16	25 TUBE	ROHS Exempt	NIAU	N/A for Pkg Type	25 to 25	TPS7H1101HKREM

(1) **Status:** For more details on status, see our [product life cycle](#).

(2) **Material type:** When designated, preproduction parts are prototypes/experimental devices, and are not yet approved or released for full production. Testing and final process, including without limitation quality assurance, reliability performance testing, and/or process qualification, may not yet be complete, and this item is subject to further changes or possible discontinuation. If available for ordering, purchases will be subject to an additional waiver at checkout, and are intended for early internal evaluation purposes only. These items are sold without warranties of any kind.

(3) **RoHS values:** Yes, No, RoHS Exempt. See the [TI RoHS Statement](#) for additional information and value definition.

(4) **Lead finish/Ball material:** Parts may have multiple material finish options. Finish options are separated by a vertical ruled line. Lead finish/Ball material values may wrap to two lines if the finish value exceeds the maximum column width.

(5) **MSL rating/Peak reflow:** The moisture sensitivity level ratings and peak solder (reflow) temperatures. In the event that a part has multiple moisture sensitivity ratings, only the lowest level per JEDEC standards is shown. Refer to the shipping label for the actual reflow temperature that will be used to mount the part to the printed circuit board.

(6) **Part marking:** There may be an additional marking, which relates to the logo, the lot trace code information, or the environmental category of the part.

Multiple part markings will be inside parentheses. Only one part marking contained in parentheses and separated by a "~" will appear on a part. If a line is indented then it is a continuation of the previous line and the two combined represent the entire part marking for that device.

Important Information and Disclaimer: The information provided on this page represents TI's knowledge and belief as of the date that it is provided. TI bases its knowledge and belief on information provided by third parties, and makes no representation or warranty as to the accuracy of such information. Efforts are underway to better integrate information from third parties. TI has taken and continues to take reasonable steps to provide representative and accurate information but may not have conducted destructive testing or chemical analysis on incoming materials and chemicals. TI and TI suppliers consider certain information to be proprietary, and thus CAS numbers and other limited information may not be available for release.

In no event shall TI's liability arising out of such information exceed the total purchase price of the TI part(s) at issue in this document sold by TI to Customer on an annual basis.

TUBE

*All dimensions are nominal

Device	Package Name	Package Type	Pins	SPQ	L (mm)	W (mm)	T (μm)	B (mm)
5962R1320202VXC	HKR	CFP	16	25	506.98	26.16	6220	NA
5962R1320202VXC.A	HKR	CFP	16	25	506.98	26.16	6220	NA
TPS7H1101AHKR/EM	HKR	CFP	16	25	506.98	26.16	6220	NA
TPS7H1101HKR/EM	HKR	CFP	16	25	506.98	26.16	6220	NA

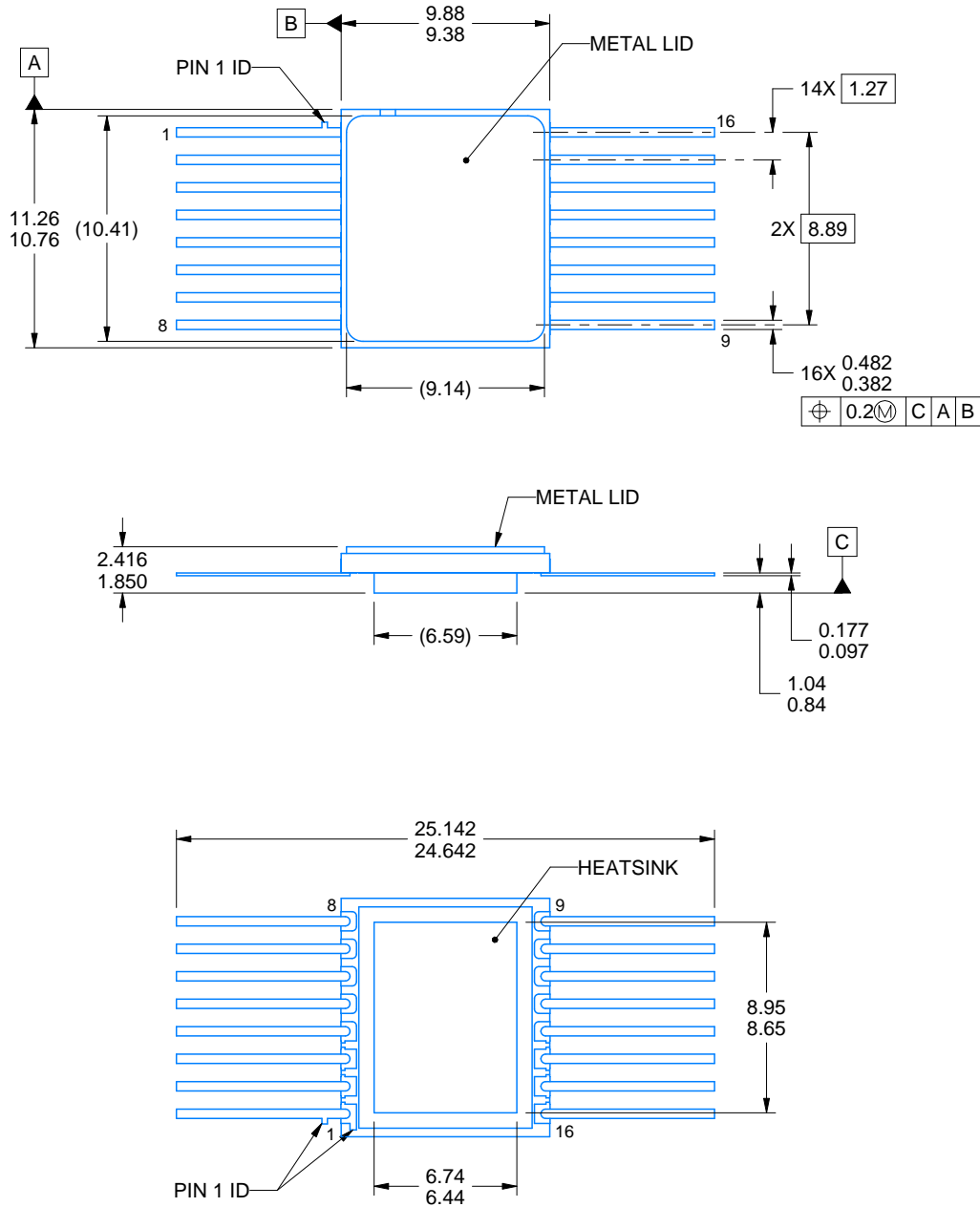
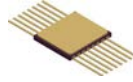

4226020/C 08/2022

NOTES:

1. All linear dimensions are in millimeters. Any dimensions in parenthesis are for reference only. Dimensioning and tolerancing per ASME Y14.5M.
2. This drawing is subject to change without notice.
3. This package is hermetically sealed with a metal lid. Lid is connected to Heatsink.
4. The terminals are gold plated.
5. Falls within MIL-STD-1835 CDFP-F11A.

EXAMPLE BOARD LAYOUT

HKR0016A

CFP - 2.416 mm max height

CERAMIC DUAL FLATPACK

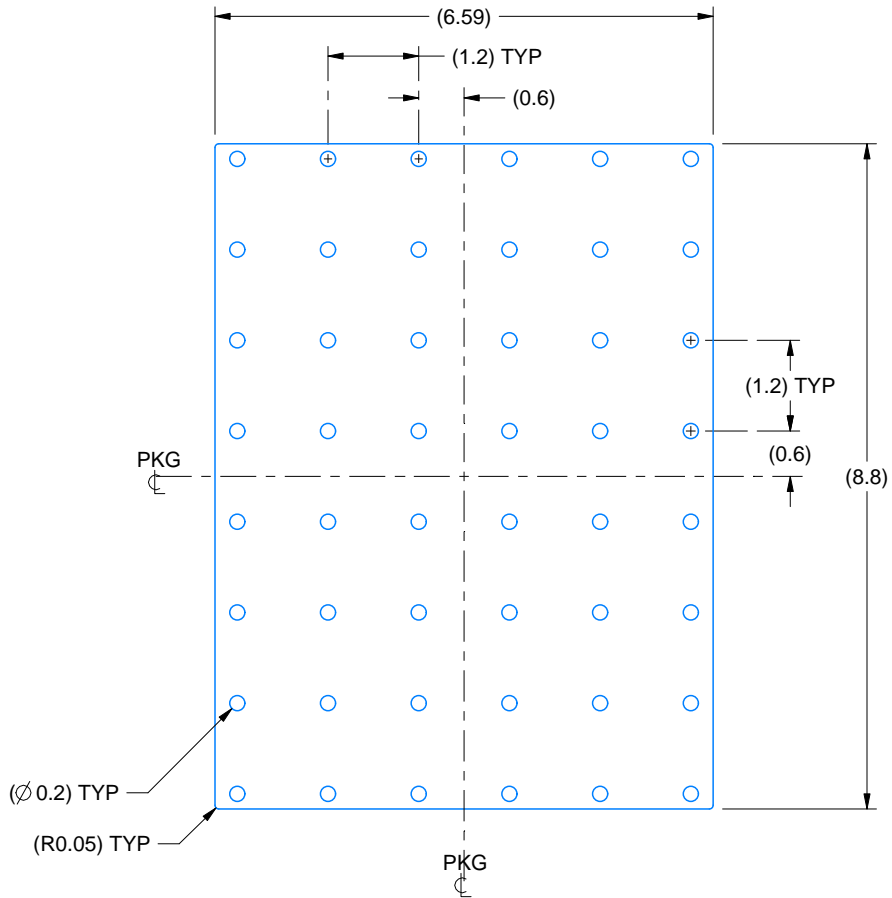

HEATSINK LAND PATTERN EXAMPLE
EXPOSED METAL SHOWN
SCALE:10X

4226020/C 08/2022

IMPORTANT NOTICE AND DISCLAIMER

TI PROVIDES TECHNICAL AND RELIABILITY DATA (INCLUDING DATA SHEETS), DESIGN RESOURCES (INCLUDING REFERENCE DESIGNS), APPLICATION OR OTHER DESIGN ADVICE, WEB TOOLS, SAFETY INFORMATION, AND OTHER RESOURCES "AS IS" AND WITH ALL FAULTS, AND DISCLAIMS ALL WARRANTIES, EXPRESS AND IMPLIED, INCLUDING WITHOUT LIMITATION ANY IMPLIED WARRANTIES OF MERCHANTABILITY, FITNESS FOR A PARTICULAR PURPOSE OR NON-INFRINGEMENT OF THIRD PARTY INTELLECTUAL PROPERTY RIGHTS.

These resources are intended for skilled developers designing with TI products. You are solely responsible for (1) selecting the appropriate TI products for your application, (2) designing, validating and testing your application, and (3) ensuring your application meets applicable standards, and any other safety, security, regulatory or other requirements.

These resources are subject to change without notice. TI grants you permission to use these resources only for development of an application that uses the TI products described in the resource. Other reproduction and display of these resources is prohibited. No license is granted to any other TI intellectual property right or to any third party intellectual property right. TI disclaims responsibility for, and you will fully indemnify TI and its representatives against, any claims, damages, costs, losses, and liabilities arising out of your use of these resources.

TI's products are provided subject to [TI's Terms of Sale](#) or other applicable terms available either on [ti.com](https://www.ti.com) or provided in conjunction with such TI products. TI's provision of these resources does not expand or otherwise alter TI's applicable warranties or warranty disclaimers for TI products.

TI objects to and rejects any additional or different terms you may have proposed.

Mailing Address: Texas Instruments, Post Office Box 655303, Dallas, Texas 75265

Copyright © 2025, Texas Instruments Incorporated

Looking for pricing, stock, or lifecycle information?

Click below to explore more details on WIN SOURCE:

 [View TPS7H1101HKR/EM on WIN SOURCE](#)

 [Texas Instruments](#) Information

Optimize Your Supply Chain with WIN SOURCE Solutions

-  Global Sourcing Solution
-  Obsolete Management
-  Cost Control Management
-  Shortage Management
-  Alternative Solution
-  Excess Inventory Management