



# THE DATASHEET OF HDMI2C1-5DIJ



# LMZM33606 3.5-V to 36-V Input, 1-V to 20-V Output, 6-A Power Module

## 1 Features

- Small Complete Solution Size: < 250 mm<sup>2</sup>
  - Requires as few as 4 External Components
  - 16 mm × 10 mm × 4 mm QFN Package
- Supports 5-V, 12-V, 24-V, 28-V Input Rails
  - 1-V to 20-V Output Voltage Range
  - Pin Compatible with 4-A LMZM33604
- Meets EN55011 Radiated Emissions
- Configurable as Negative Output Voltage
- Adjustable Features for Design Flexibility
  - Switching Frequency (350 kHz to 2.2 MHz)
  - Synchronization to an External Clock
  - Selectable Auto Mode or FPWM Mode
    - Auto: Boost Efficiency at Light Loads
    - FPWM: Fixed Frequency Over Entire Load
  - Adjustable Soft Start and Tracking Input
  - Precision Enable to Program System UVLO
- Protection Features
  - Hiccup Mode Current Limit
  - Overtemperature Protection
  - Power-Good Output
- Operate in Rugged Environments
  - Up to 50-W Output Power at 85°C, No Airflow
  - Operating Junction Range: –40°C to +125°C
  - Operating Ambient Range: –40°C to +105°C
  - Shock and Vibration Tested to Mil-STD-883D

## 2 Applications

- Industrial, Medical and Test Equipment
- General Purpose Wide VIN Regulation
- [Inverted Output Applications](#)

## 3 Description

The LMZM33606 power module is an easy-to-use integrated power solution that combines a 6-A DC/DC converter with power MOSFETs, a shielded inductor, and passives in a low-profile package. This power solution requires as few as four external components and eliminates the loop compensation and inductor part selection from the design process.

The 16 mm × 10 mm × 4 mm, 41-pin, QFN package is easy to solder onto a printed circuit board and allows a compact, low-profile point-of-load design. The LMZM33606 feature set includes power good, adjustable soft start, tracking, synchronization, programmable UVLO, prebias start-up, selectable auto or FPWM modes, as well as over-current and over-temperature protection. The LMZM33606 can be configured as negative output voltage for [inverting applications](#).

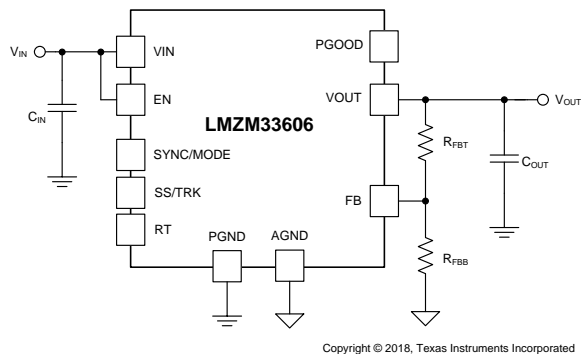
### Device Information

DEVICE NUMBER	PACKAGE	BODY SIZE (NOM)
LMZM33606	QFN (41)	16.00 mm × 10.00 mm

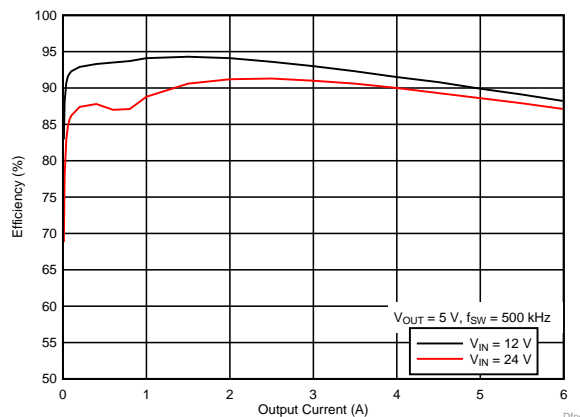
### Minimum Solution Size



### Simplified Schematic



### Typical Efficiency (Auto Mode)



## Table of Contents

<b>1 Features</b> .....	<b>1</b>	<b>8 Application and Implementation</b> .....	<b>27</b>
<b>2 Applications</b> .....	<b>1</b>	8.1 Application Information.....	27
<b>3 Description</b> .....	<b>1</b>	8.2 Typical Application .....	27
<b>4 Revision History</b> .....	<b>2</b>	<b>9 Power Supply Recommendations</b> .....	<b>29</b>
<b>5 Pin Configuration and Functions</b> .....	<b>3</b>	<b>10 Layout</b> .....	<b>29</b>
<b>6 Specifications</b> .....	<b>5</b>	10.1 Layout Guidelines .....	29
6.1 Absolute Maximum Ratings .....	5	10.2 Layout Example .....	30
6.2 ESD Ratings.....	5	10.3 Theta JA vs PCB Area .....	31
6.3 Recommended Operating Conditions.....	6	10.4 Package Specifications .....	31
6.4 Thermal Information .....	6	10.5 EMI.....	32
6.5 Electrical Characteristics.....	7	<b>11 Device and Documentation Support</b> .....	<b>34</b>
6.6 Switching Characteristics .....	8	11.1 Device Support.....	34
6.7 Typical Characteristics ( $V_{IN} = 12\text{ V}$ ).....	9	11.2 Receiving Notification of Documentation Updates	34
6.8 Typical Characteristics ( $V_{IN} = 24\text{ V}$ ).....	11	11.3 Community Resources.....	34
6.9 Typical Characteristics ( $V_{IN} = 36\text{ V}$ ).....	13	11.4 Trademarks .....	34
<b>7 Detailed Description</b> .....	<b>15</b>	11.5 Electrostatic Discharge Caution.....	34
7.1 Overview .....	15	11.6 Glossary .....	34
7.2 Functional Block Diagram .....	15	<b>12 Mechanical, Packaging, and Orderable</b>	
7.3 Feature Description.....	16	<b>Information</b> .....	<b>34</b>
7.4 Device Functional Modes.....	26	12.1 Tape and Reel Information .....	38

## 4 Revision History

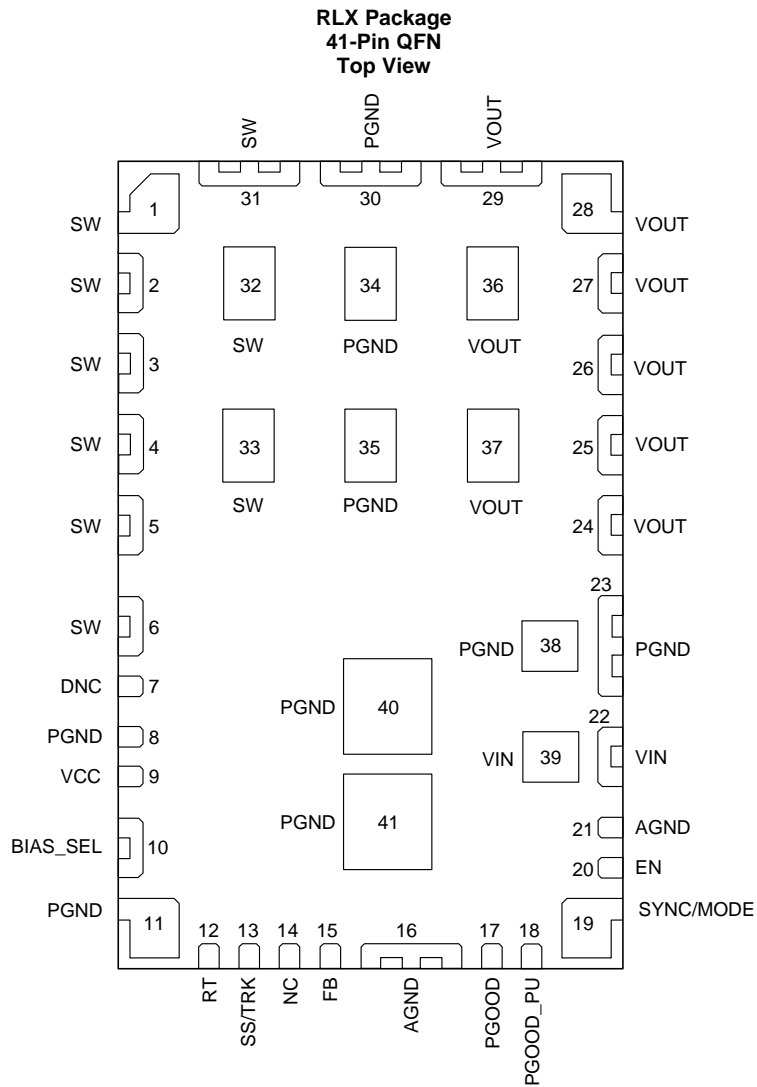
NOTE: Page numbers for previous revisions may differ from page numbers in the current version.

<b>Changes from Revision A (October 2018) to Revision B</b>	<b>Page</b>
• Added information on internal LDO and BIAS_SEL .....	22

<b>Changes from Original (June 2018) to Revision A</b>	<b>Page</b>
• First release of production-data data sheet .....	1

## 5 Pin Configuration and Functions



### Pin Functions

PIN		TYPE	DESCRIPTION
NAME	NO.		
AGND	16, 21	G	Analog ground. Zero voltage reference for internal references and logic. These pins are not connected to one another internal to the device and must be connected to one another externally. Do not connect these pins to PGND; the AGND to PGND connection is made internal to the device. See the <a href="#">Layout</a> section of the datasheet for a recommended layout.
BIAS_SEL	10	I	Optional BIAS LDO supply input. An internal 470 nF capacitor is placed between this pin and PGND. Do not float; tie to PGND if not used. Tie to VOUT if $3.3\text{ V} \leq \text{VOUT} \leq 18\text{ V}$ , or tie to an external 3.3-V or 5-V rail if available to improve efficiency.
DNC	7	—	Do not connect. This pin is connected to internal circuitry. Do not connect this pin to AGND, PGND, or any other voltage. <b>This pin must be soldered to an isolated pad.</b>
EN	20	I	Precision enable input to regulator. Do not float. High = ON, Low = OFF. Can be tied to VIN. Precision enable input allows adjustable system UVLO using external resistor divider.
FB	15	I	Feedback input. Connect the center point of the feedback resistor divider to this pin. Connect the upper resistor ( $R_{FBT}$ ) of the feedback divider to $V_{OUT}$ at the desired point of regulation. Connect the lower resistor ( $R_{FBB}$ ) of the feedback divider to AGND.
NC	14	—	Not internally connected.
PGND	8, 11, 23, 30, 34, 35, 38, 40, 41	G	Power ground. This is the return current path for the power stage of the device. Connect these pins to the low side of the input source, load, and bypass capacitors associated with VIN and VOUT using power ground planes on the PCB. Not all pins are connected to PGND internal to the device; connections must be made externally. Connect pad 40 and 41 to the ground planes using multiple vias for good thermal performance.
PGOOD	17	O	Open drain output for power-good flag. Internal to the device, a 100-k $\Omega$ pullup resistor is placed between this pin and the PGOOD_PU pin.
PGOOD_PU	18	I	Power-good pull-up supply. Connect to logic rail or other DC voltage no higher than 20 V.
RT	12	I	An external timing resistor connected between this pin and AGND adjusts the switching frequency of the device. If floating, the default switching frequency is 500 kHz. Do not short to ground.
SS/TRK	13	I	Soft start / tracking control pin. Leave this pin floating to use the 5-ms internal soft-start ramp. To increase the internal soft start ramp time, simply connect a capacitor between this pin and AGND. This pin sources 2- $\mu$ A of current to charge this external capacitor. Connect to external voltage ramp for tracking. Do not connect to ground.
SW	1, 2, 3, 4, 5, 6, 31, 32, 33	O	Switch node. Connect these pins to a small copper island under the device for thermal relief. Do not place any external components on these pins or tie them to a pin of another function.
SYNC/MODE	19	I	Synchronization input and Mode setting pin. Do not float; tie to AGND or logic high if not used. Connect to an external clock to synchronize (see <a href="#">Synchronization (SYNC/MODE)</a> ). Connect to AGND to select Auto mode or connect to logic high to select FPWM mode. (see <a href="#">Mode Select (Auto or FPWM)</a> ).
VCC	9	O	Output of internal bias supply. Used to supply internal control circuits and drivers. Do not place any external component on this pin or tie it to a pin of another function.
VIN	22, 39	I	Input supply voltage. Connect external input capacitors between these pins and PGND.
VOUT	24, 25, 26, 27, 28, 29, 36, 37	O	Output voltage. These pins are connected to the output of the internal inductor. Connect these pins to the output VOUT load and connect external bypass capacitors between these pins and PGND.

## 6 Specifications

### 6.1 Absolute Maximum Ratings

Over operating ambient temperature range (unless otherwise noted)<sup>(1)</sup>

		MIN	MAX	UNIT	
Input voltage	VIN to PGND	-0.3	42	V	
	EN to AGND	-0.3	V <sub>IN</sub> + 0.3	V	
	FB, RT, SS/TRK to AGND	-0.3	5	V	
	PGOOD to AGND	-0.1	20	V	
	SYNC/MODE to AGND	-0.3	5.5	V	
	BIAS_SEL to AGND	-0.3	Lower of (V <sub>IN</sub> +0.3) and 20	V	
	AGND to PGND	-0.3	0.3	V	
Output voltage	VOUT to PGND	-0.3	V <sub>IN</sub>	V	
	SW to PGND	-0.3	V <sub>IN</sub> + 0.3	V	
	SW to PGND (<10 ns transients)	-3.5	42	V	
	VCC to PGND	-0.3	5	V	
Peak Reflow Case Temperature			240	°C	
Maximum Number of Reflows Allowed			1		
Temperature	Maximum junction temperature, T <sub>J</sub> <sup>(2)</sup>		-40	125	°C
	Storage temperature, T <sub>stg</sub>		-55	150	°C
Mechanical shock	Mil-STD-883D, Method 2002.3, 1 msec, 1/2 sine, mounted		500	G	
Mechanical vibration	Mil-STD-883D, Method 2007.2, 20 to 2000 Hz		20	G	

- (1) Stresses beyond those listed under *Absolute Maximum Ratings* may cause permanent damage to the device. These are stress ratings only, which do not imply functional operation of the device at these or any other conditions beyond those indicated under the recommended operating conditions. Exposure to absolute-maximum-rated conditions for extended periods may affect device reliability.
- (2) The ambient temperature is the air temperature of the surrounding environment. The junction temperature is the temperature of the internal power IC when the device is powered. Operating below the maximum ambient temperature, as shown in the safe operating area (SOA) curves in the typical characteristics sections, ensures that the maximum junction temperature of any component inside the module is never exceeded.

### 6.2 ESD Ratings

			VALUE	UNIT
V <sub>(ESD)</sub>	Electrostatic discharge	Human-body model (HBM), per ANSI/ESDA/JEDEC JS-001 <sup>(1)</sup>	±1500	V
		Charged-device model (CDM), per JEDEC specification JESD22-C101 <sup>(2)</sup>	±1000	

- (1) JEDEC document JEP155 states that 500-V HBM allows safe manufacturing with a standard ESD control process.
- (2) JEDEC document JEP157 states that 250-V CDM allows safe manufacturing with a standard ESD control process.

### 6.3 Recommended Operating Conditions

Over operating ambient temperature range (unless otherwise noted)

	MIN	MAX	UNIT
Input voltage, $V_{IN}$	3.5 <sup>(1)</sup>	36	V
Output voltage, $V_{OUT}$	1	20	V
EN voltage, $V_{EN}$	0	$V_{IN}$	V
PGOOD pullup voltage, $V_{PGOOD}$	0	18	V
PGOOD sink current	0	5	mA
BIAS_SEL	3.3	Lower of $V_{IN}$ and 18	V
Output current, $I_{OUT}$	0	6	A
Switching frequency, $F_{SW}$	350	1200	kHz
Operating ambient temperature, $T_A$	–40	105	°C
Input Capacitance, $C_{IN}$	20 <sup>(2)</sup>		μF
Output Capacitance, $C_{OUT}$	min <sup>(3)</sup>	700	μF

- (1) For output voltages  $\leq 5$  V, the recommended minimum  $V_{IN}$  is 3.5 V or ( $V_{OUT} + 1$  V), whichever is greater. For output voltages  $> 5$  V, the recommended minimum  $V_{IN}$  is ( $1.1 \times V_{OUT}$ ). See [Voltage Dropout](#) for more information.
- (2) A minimum of 20 μF ceramic input capacitance is required for proper operation. An additional 100 μF of bulk capacitance is recommended for applications with transient load requirements. (see [Input Capacitor Selection](#)).
- (3) The minimum amount of required output capacitance varies depending on the output voltage (see [Output Capacitor Selection](#)).

### 6.4 Thermal Information

THERMAL METRIC <sup>(1)</sup>		LMZM33606	UNIT
		RLX(B2QFN)	
		41 PINS	
$R_{\theta JA}$	Junction-to-ambient thermal resistance <sup>(2)</sup>	13.9	°C/W
$\psi_{JT}$	Junction-to-top characterization parameter <sup>(3)</sup>	1.2	°C/W
$\psi_{JB}$	Junction-to-board characterization parameter <sup>(4)</sup>	6.2	°C/W
$T_{SHDN}$	Thermal Shutdown Temperature	160	°C
	Thermal Shutdown Hysteresis	25	°C

- (1) For more information about traditional and new thermal metrics, see the *Semiconductor and IC Package Thermal Metrics* application report, [SPRA953](#).
- (2) The junction-to-ambient thermal resistance,  $R_{\theta JA}$ , applies to devices soldered directly to a 75 mm x 75 mm double-sided PCB with 2 oz. copper and natural convection cooling. Additional airflow reduces  $R_{\theta JA}$ .
- (3) The junction-to-top board characterization parameter,  $\psi_{JT}$ , estimates the junction temperature,  $T_J$ , of a device in a real system, using a procedure described in JESD51-2A (section 6 and 7).  $T_J = \psi_{JT} \times P_{dis} + T_T$ ; where  $P_{dis}$  is the power dissipated in the device and  $T_T$  is the temperature of the top of the device.
- (4) The junction-to-board characterization parameter,  $\psi_{JB}$ , estimates the junction temperature,  $T_J$ , of a device in a real system, using a procedure described in JESD51-2A (sections 6 and 7).  $T_J = \psi_{JB} \times P_{dis} + T_B$ ; where  $P_{dis}$  is the power dissipated in the device and  $T_B$  is the temperature of the board 1mm from the device.

## 6.5 Electrical Characteristics

Limits apply over  $T_A = -40^\circ\text{C}$  to  $+105^\circ\text{C}$ ,  $V_{IN} = 24\text{ V}$ ,  $V_{OUT} = 5\text{ V}$ ,  $I_{OUT} = I_{OUT\text{ maximum}}$ ,  $f_{sw} = 500\text{ kHz}$ , FPWM mode (unless otherwise noted);  $C_{IN1} = 3 \times 10\text{ }\mu\text{F}$ , 50-V, 1210 ceramic;  $C_{IN2} = 2 \times 4.7\text{ }\mu\text{F}$ , 50-V, 1210 ceramic;  $C_{OUT} = 6 \times 22\text{ }\mu\text{F}$ , 25-V, 1210 ceramic. Minimum and maximum limits are specified through production test or by design. Typical values represent the most likely parametric norm and are provided for reference only.

PARAMETER		TEST CONDITIONS	MIN	TYP	MAX	UNIT
<b>INPUT VOLTAGE (<math>V_{IN}</math>)</b>						
$V_{IN}$	Input voltage range	Over $I_{OUT}$ range, $V_{OUT} = 2.5\text{ V}$ , $f_{sw} = 350\text{ kHz}$	3.5 <sup>(1)</sup>		36	V
	$V_{IN}$ turn on	$V_{IN}$ increasing, $V_{OUT} = 2.5\text{ V}$ , $I_{OUT} = 0\text{ A}$		3.12		V
	$V_{IN}$ turn off	$V_{IN}$ decreasing, $V_{OUT} = 2.5\text{ V}$ , $I_{OUT} = 0\text{ A}$		2.62		V
$I_{SHDN}$	Shutdown supply current	$V_{IN} = 12\text{ V}$ , $V_{EN} = 0\text{ V}$ , $I_{OUT} = 0\text{ A}$		0.8	10	$\mu\text{A}$
<b>INTERNAL LDO (<math>V_{CC}</math>, <math>BIAS\_SEL</math>)</b>						
$V_{CC}$	Internal $V_{CC}$ voltage	PWM operation		3.27		V
		PFM operation		3.1		V
$I_{BIAS\_SEL}$	BIAS_SEL quiescent current (non-switching)	$V_{IN} = 12\text{ V}$ , $V_{FB} = 1.5\text{ V}$ , $V_{EN} = 2\text{ V}$ , $V_{BIAS\_SEL} = 3.3\text{ V}$		21	50	$\mu\text{A}$
<b>FEEDBACK</b>						
$V_{FB}$	Feedback voltage <sup>(2)</sup>	$-40^\circ\text{C} \leq T_J = T_A \leq 125^\circ\text{C}$ , $I_{OUT} = 0\text{ A}$ , Over $V_{IN}$ range, $V_{OUT} = 2.5\text{ V}$ , $f_{sw} = 350\text{ kHz}$	0.987	1.006	1.017	V
	Load regulation	Over $I_{OUT}$ range, $T_A = 25^\circ\text{C}$		0.1%		
$I_{FB}$	Feedback leakage current	$V_{FB} = 1\text{ V}$		0.2	65	nA
<b>CURRENT</b>						
$I_{OUT}$	Output current	Natural convection, $T_A = 25^\circ\text{C}$	0		6	A
	Overcurrent threshold			9		A
<b>PERFORMANCE</b>						
$\eta$	Efficiency	$I_{OUT} = 3\text{ A}$ , $T_A = 25^\circ\text{C}$		91%		
<b>SOFT START</b>						
$T_{SS}$	Internal soft start time	SS pin open		5		ms
$I_{SSC}$	Soft-start charge current	$V_{IN} = 12\text{ V}$ , $V_{FB} = 1.5\text{ V}$ , $V_{EN} = 2\text{ V}$ , $V_{SS/TRK} = 0.5\text{ V}$	1.8	2	2.2	$\mu\text{A}$
<b>ENABLE (EN)</b>						
$V_{EN-H}$	EN rising threshold		1.14	1.2	1.25	V
$V_{EN-HYS}$	EN hysteresis voltage			-100		mV
$I_{EN}$	EN Input leakage current	$V_{IN} = 12\text{ V}$ , $V_{FB} = 1.5\text{ V}$ , $V_{EN} = 2\text{ V}$		1.4	200	nA
<b>POWER GOOD (PGOOD)</b>						
$V_{PGOOD}$	PGOOD thresholds	Overvoltage	106%	110%	113%	
		Undervoltage	86%	90%	93%	
	PGOOD low voltage	0.5-mA pullup, $V_{EN} = 0\text{ V}$			0.3	V
$V_{INPG}$	Minimum $V_{IN}$ for valid PGOOD	50- $\mu\text{A}$ pullup, $V_{EN} = 0\text{ V}$ , $T_J = T_A = 25^\circ\text{C}$		1.3	2	V

- (1) For output voltages  $\leq 5\text{ V}$ , the recommended minimum  $V_{IN}$  is 3.5 V or ( $V_{OUT} + 1\text{ V}$ ), whichever is greater. For output voltages  $> 5\text{ V}$ , the recommended minimum  $V_{IN}$  is  $(1.1 \times V_{OUT})$ . See [Voltage Dropout](#) for more information.
- (2) The overall output voltage tolerance will be affected by the tolerance of the external  $R_{FBT}$  and  $R_{FBB}$  resistors.

## 6.6 Switching Characteristics

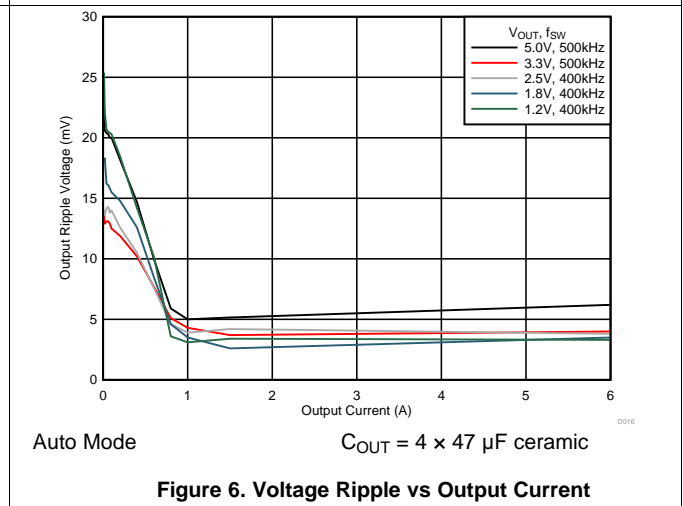
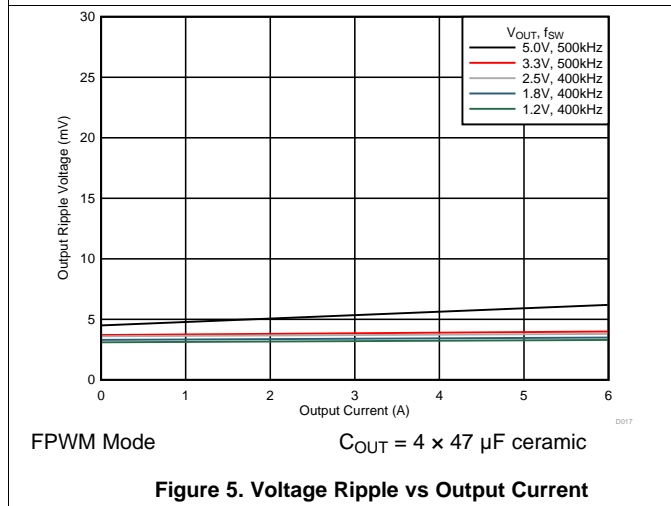
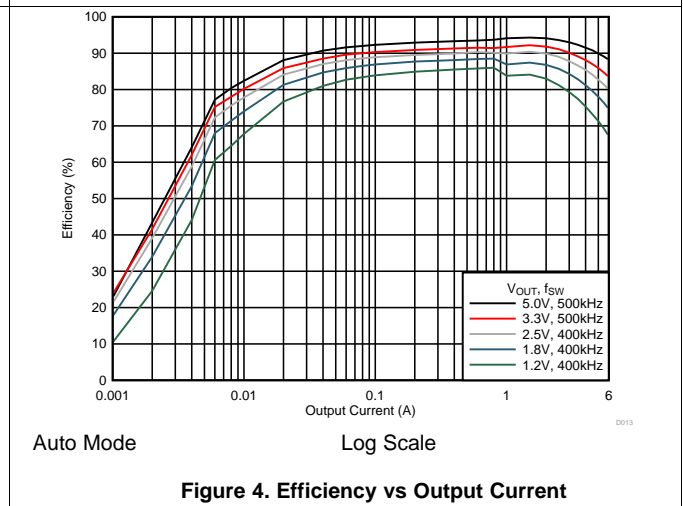
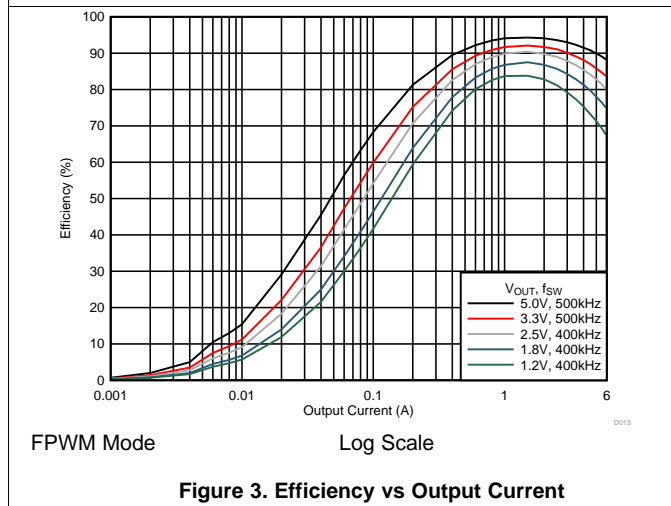
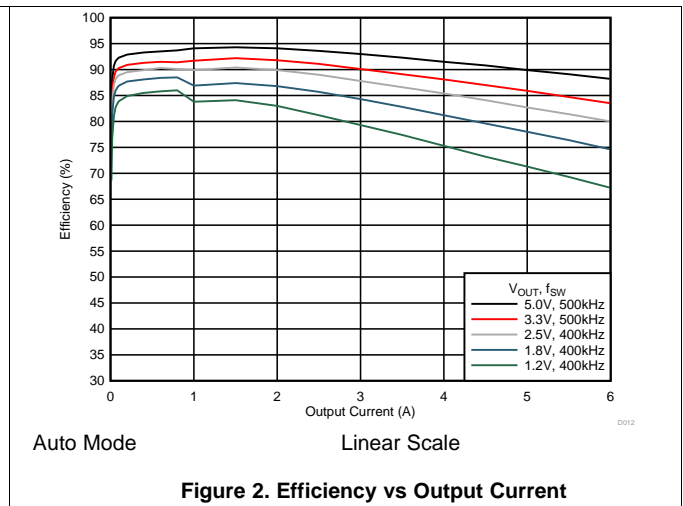
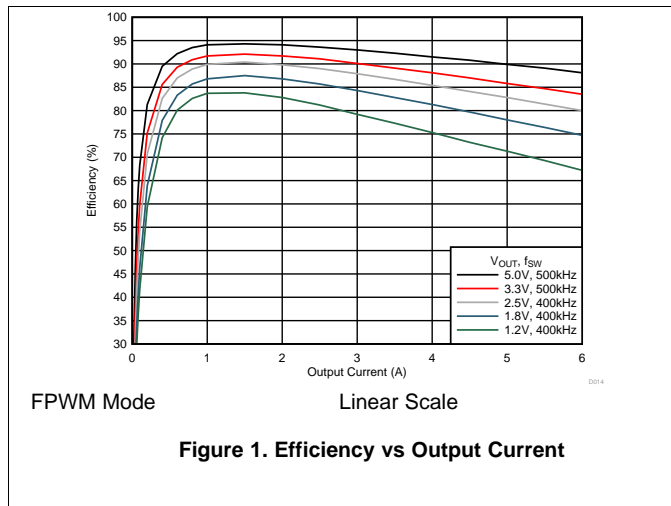
Limits apply over  $T_A = -40^{\circ}\text{C}$  to  $+105^{\circ}\text{C}$ ,  $V_{IN} = 24\text{ V}$ ,  $V_{OUT} = 5\text{ V}$ , FPWM mode (unless otherwise noted);

Minimum and maximum limits are specified through production test or by design. Typical values represent the most likely parametric norm, and are provided for reference only.

PARAMETER		TEST CONDITIONS	MIN	TYP	MAX	UNIT
<b>FREQUENCY (RT) and SYNCHRONIZATION (SYNC)</b>						
$f_{\text{SW}}$	Default switching frequency	RT pin = open, $I_{\text{OUT}} = 0\text{ A}$	440	500	560	kHz
	Switching frequency range	$I_{\text{OUT}} = 0\text{ A}$	350		2200	kHz
$V_{\text{SYNC}}$	High Threshold				2	V
	Low Threshold		0.4			V
$T_{\text{S-MIN}}$	Minimum SYNC ON/OFF time			80		ns

### 6.7 Typical Characteristics ( $V_{IN} = 12\text{ V}$ )

The typical characteristic data has been developed from actual products tested at 25°C. This data is considered typical for the device.



### Typical Characteristics ( $V_{IN} = 12\text{ V}$ ) (continued)

The typical characteristic data has been developed from actual products tested at 25°C. This data is considered typical for the device.

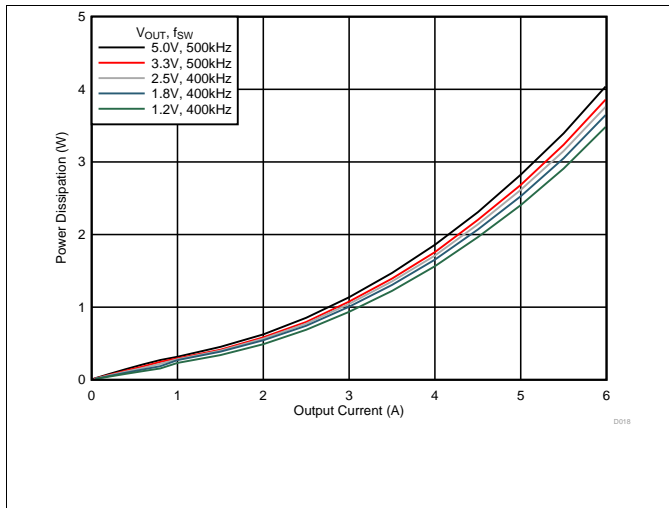


Figure 7. Power Dissipation vs Output Current

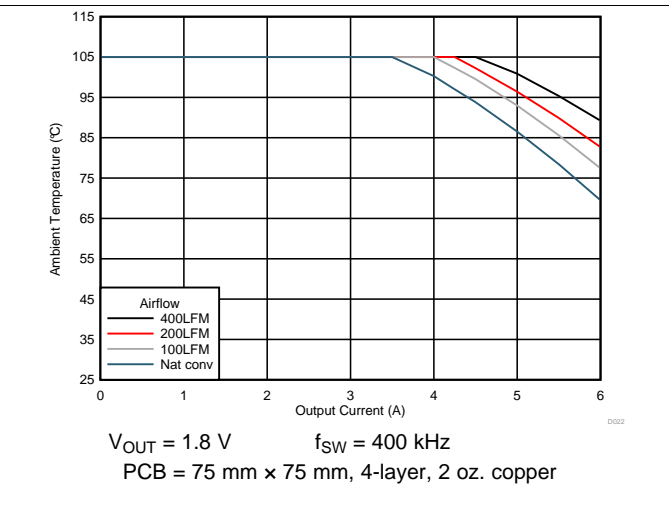


Figure 8. Safe Operating Area

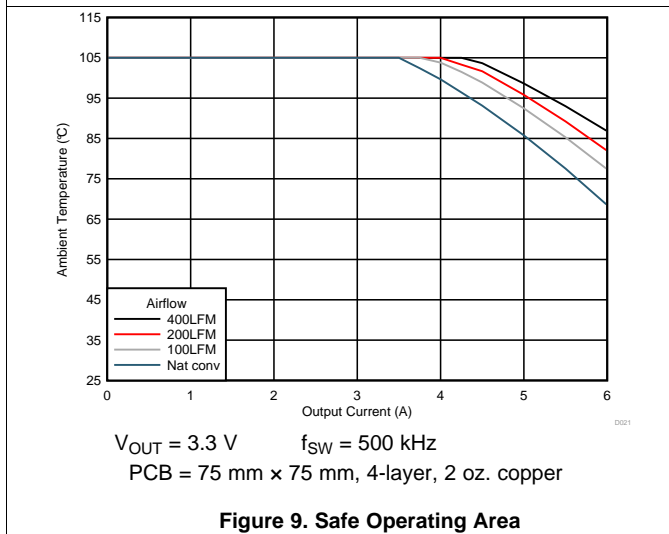


Figure 9. Safe Operating Area

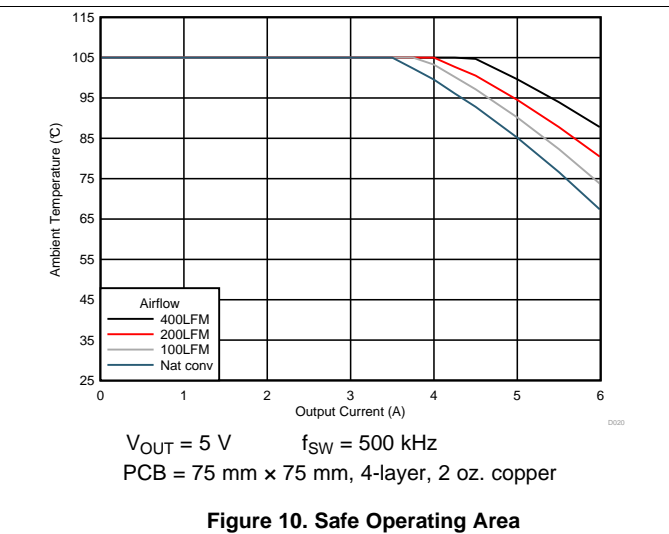
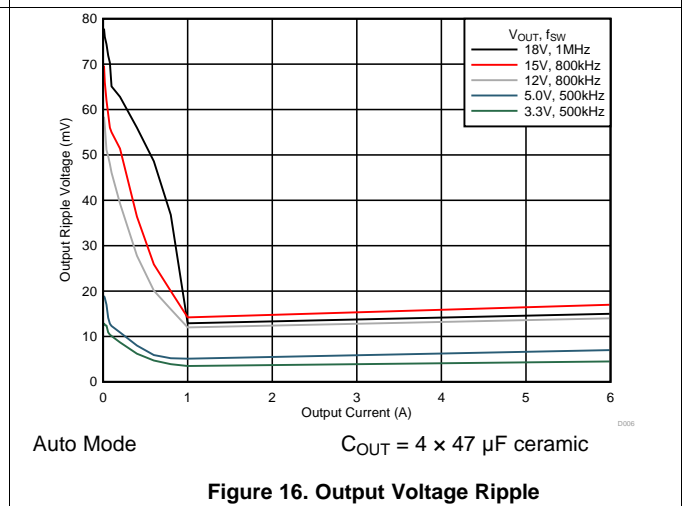
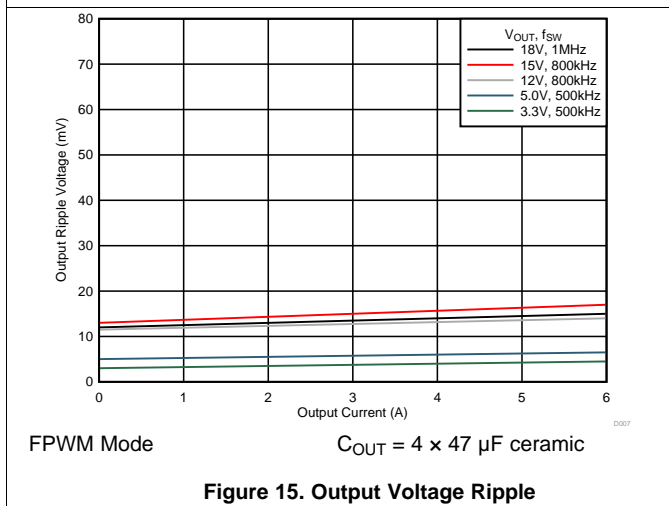
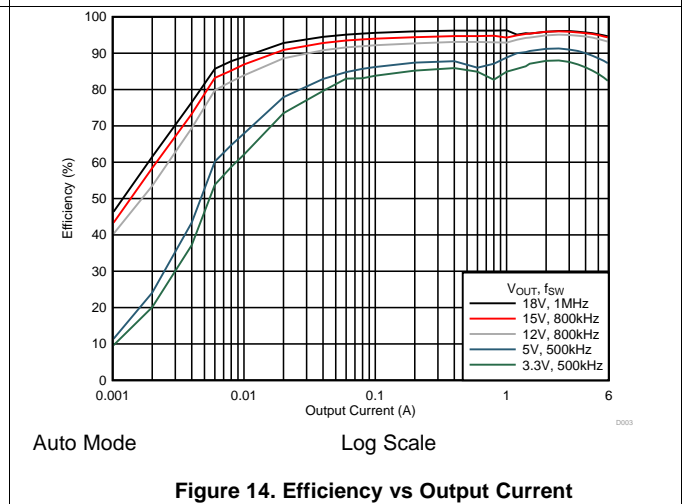
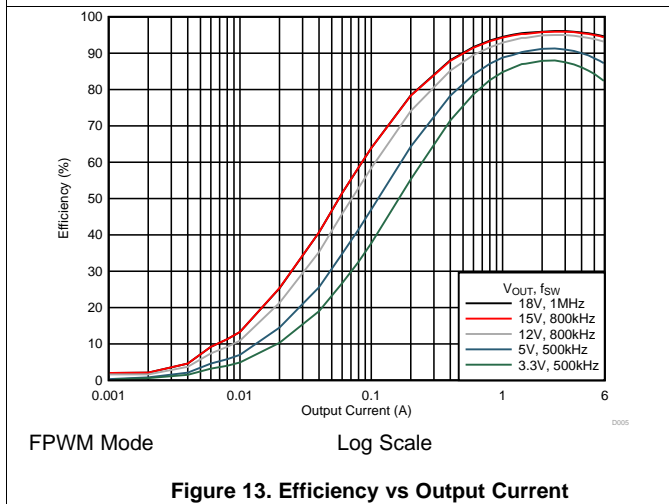
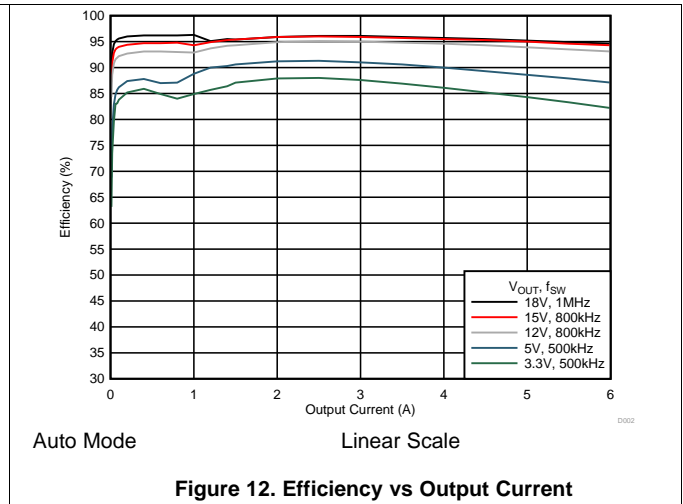
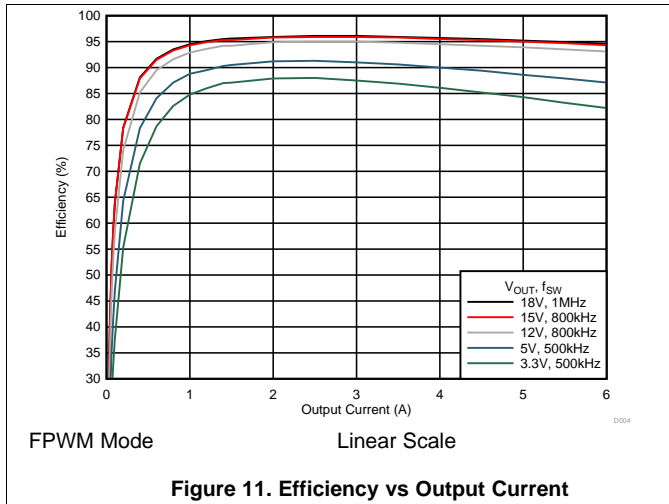


Figure 10. Safe Operating Area

### 6.8 Typical Characteristics ( $V_{IN} = 24\text{ V}$ )

The typical characteristic data has been developed from actual products tested at 25°C. This data is considered typical for the device.



### Typical Characteristics ( $V_{IN} = 24\text{ V}$ ) (continued)

The typical characteristic data has been developed from actual products tested at 25°C. This data is considered typical for the device.

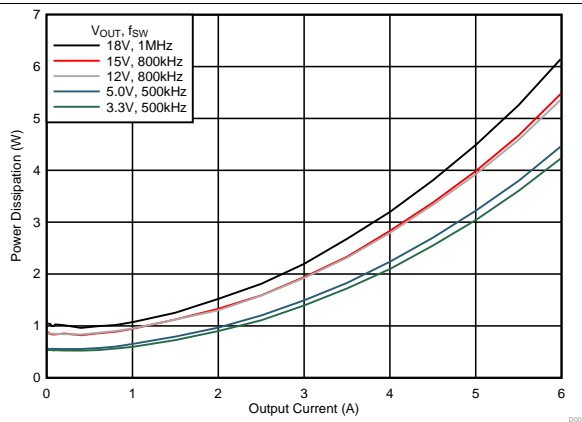
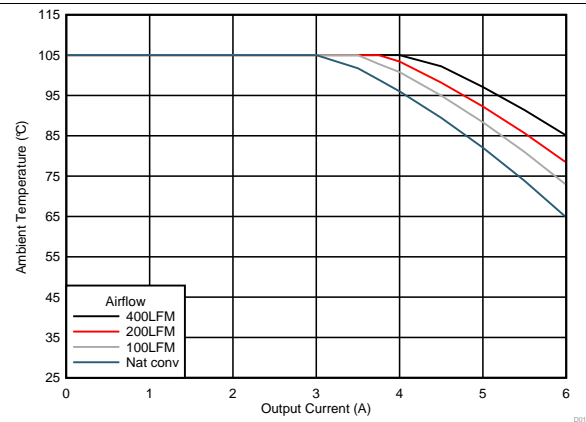
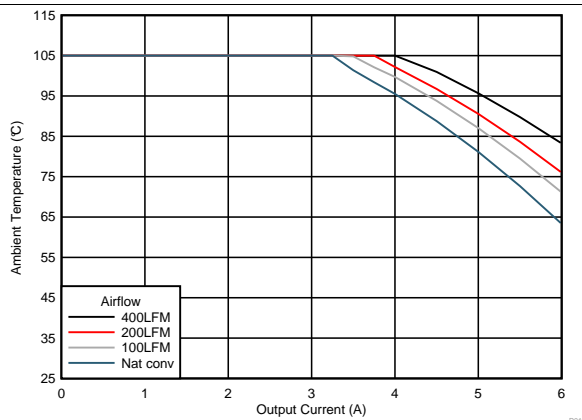


Figure 17. Power Dissipation



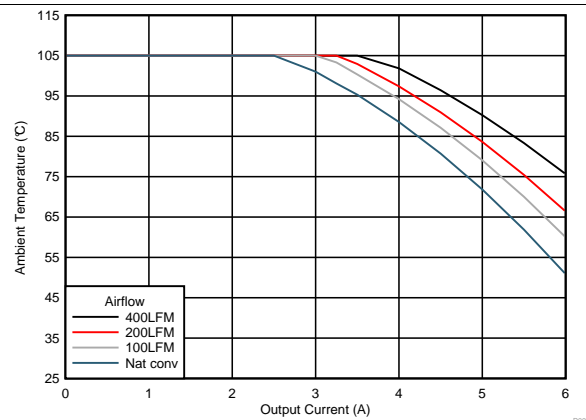
$V_{OUT} = 3.3\text{ V}$        $f_{SW} = 500\text{ kHz}$   
 PCB = 75 mm x 75 mm, 4-layer, 2 oz. copper

Figure 18. Safe Operating Area



$V_{OUT} = 5\text{ V}$        $f_{SW} = 500\text{ kHz}$   
 PCB = 75 mm x 75 mm, 4-layer, 2 oz. copper

Figure 19. Safe Operating Area

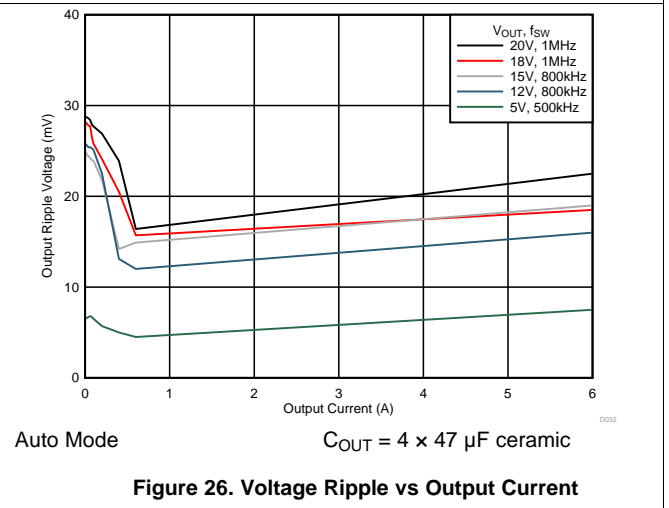
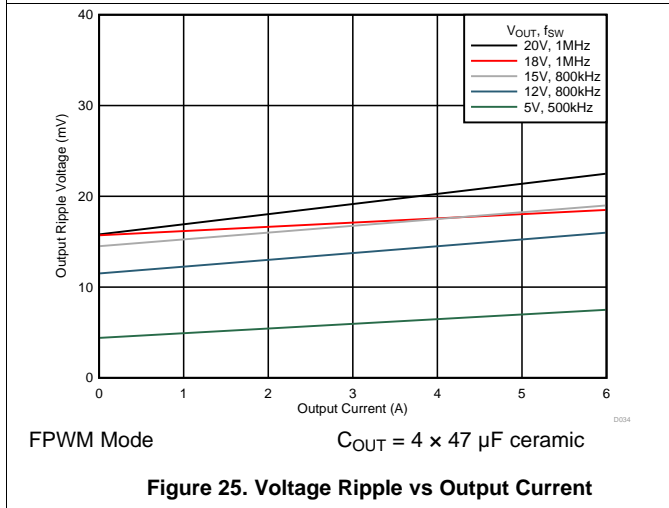
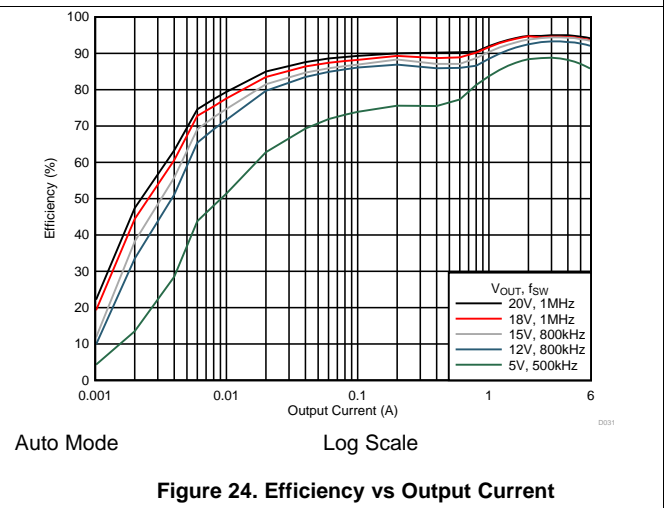
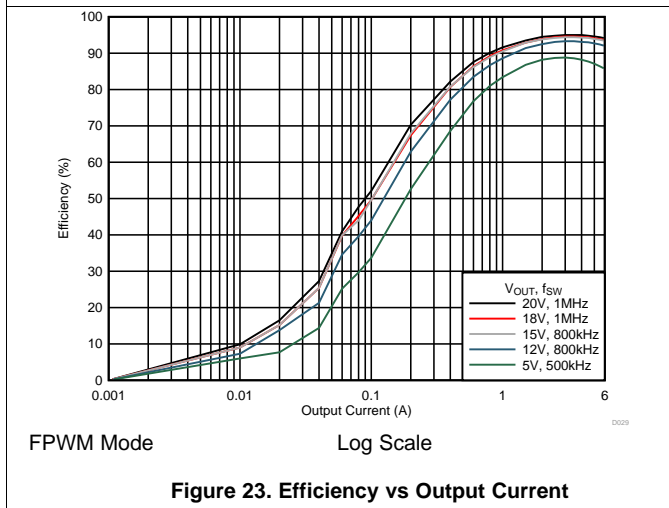
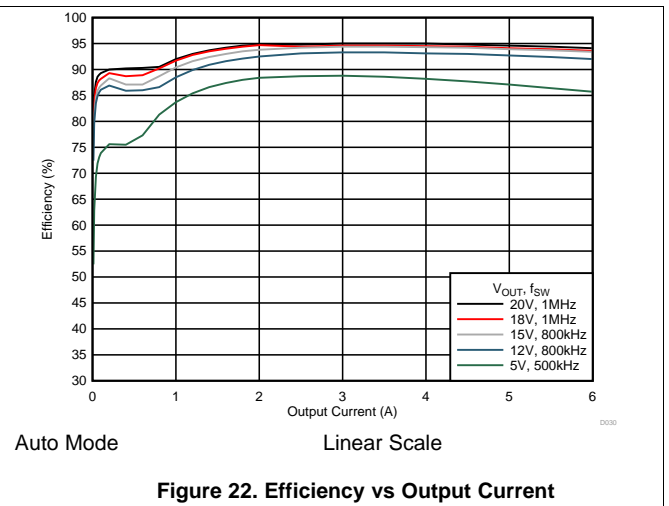
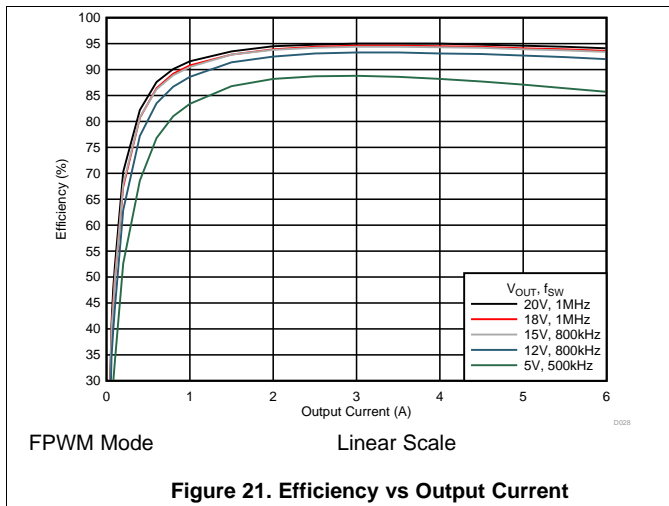


$V_{OUT} = 12\text{ V}$        $f_{SW} = 800\text{ kHz}$   
 PCB = 75 mm x 75 mm, 4-layer, 2 oz. copper

Figure 20. Safe Operating Area

### 6.9 Typical Characteristics ( $V_{IN} = 36\text{ V}$ )

The typical characteristic data has been developed from actual products tested at 25°C. This data is considered typical for the device.



### Typical Characteristics ( $V_{IN} = 36\text{ V}$ ) (continued)

The typical characteristic data has been developed from actual products tested at 25°C. This data is considered typical for the device.

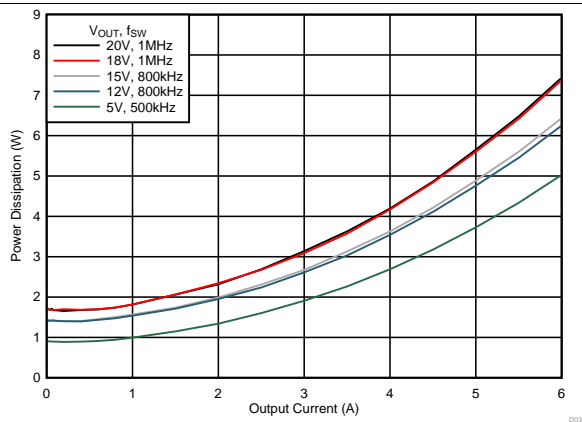
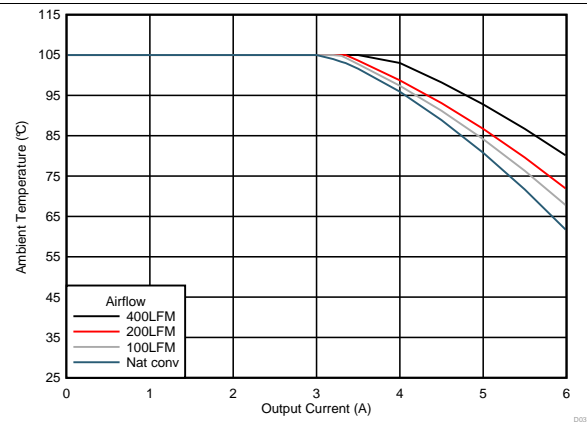
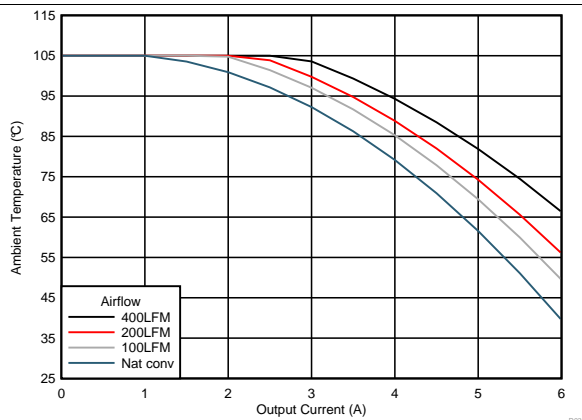


Figure 27. Power Dissipation vs Output Current



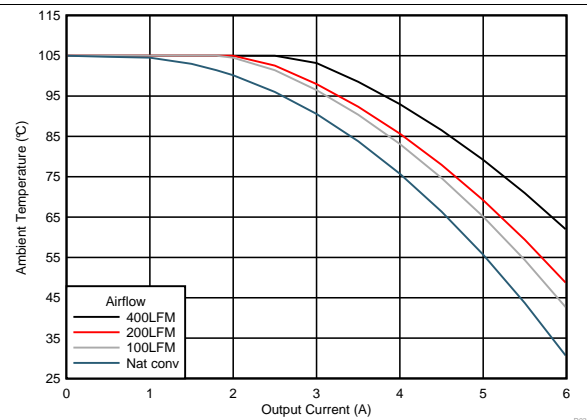
$V_{OUT} = 5\text{ V}$        $f_{SW} = 500\text{ kHz}$   
 PCB = 75 mm × 75 mm, 4-layer, 2 oz. copper

Figure 28. Safe Operating Area



$V_{OUT} = 12\text{ V}$        $f_{SW} = 800\text{ kHz}$   
 PCB = 75 mm × 75 mm, 4-layer, 2 oz. copper

Figure 29. Safe Operating Area



$V_{OUT} = 20\text{ V}$        $f_{SW} = 1\text{ MHz}$   
 PCB = 75 mm × 75 mm, 4-layer, 2 oz. copper

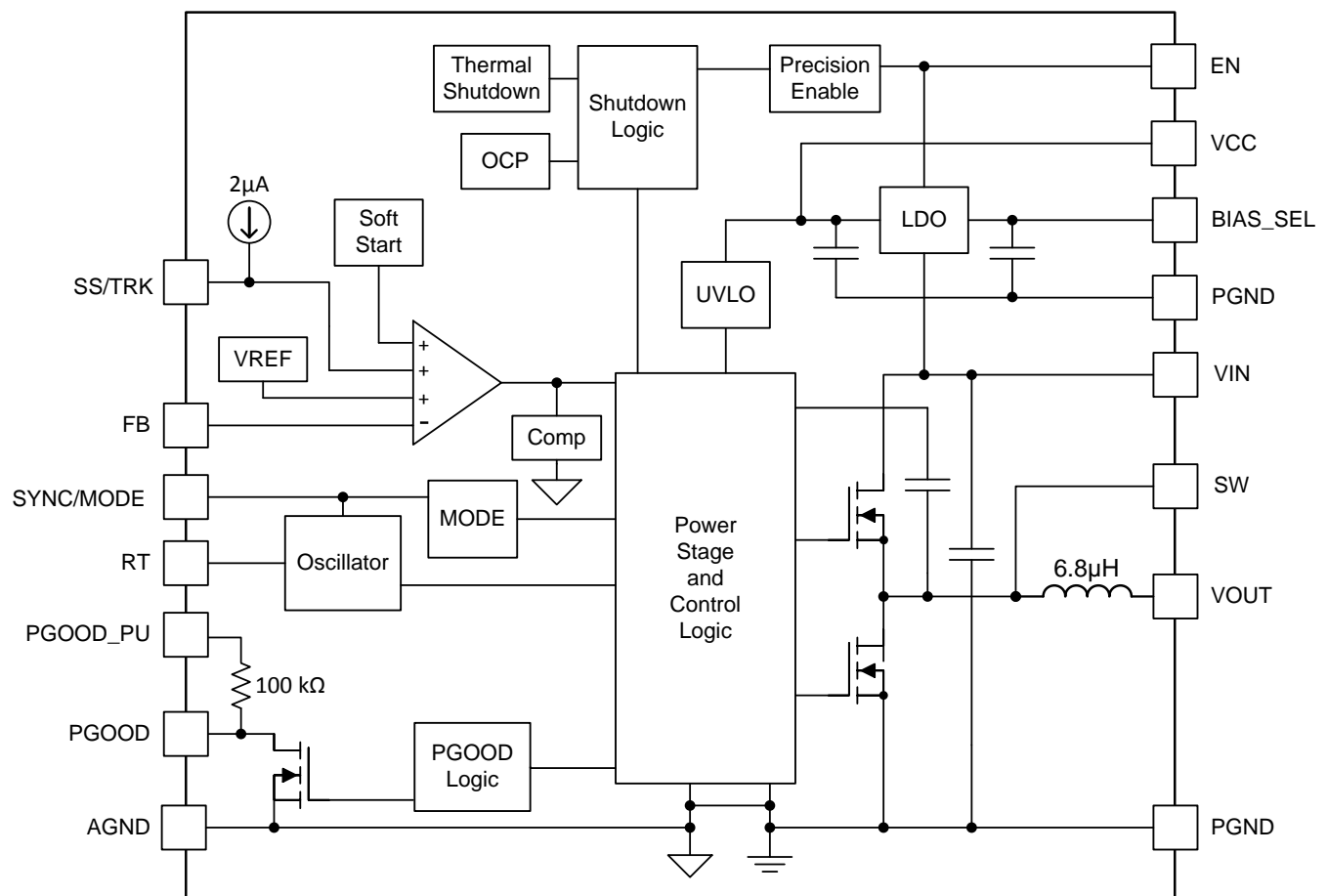
Figure 30. Safe Operating Area

## 7 Detailed Description

### 7.1 Overview

The LMZM33606 is a full-featured 36-V input, 6-A, synchronous step-down converter with controller, MOSFETs, shielded inductor, and control circuitry integrated into a low-profile, overmolded package. The device integration enables small designs, while providing the ability to adjust key parameters to meet specific design requirements. The LMZM33606 provides an output voltage range of 1 V to 20 V. An external resistor divider is used to adjust the output voltage to the desired value. The switching frequency can also be adjusted, by either an external resistor or a sync signal, which allows the LMZM33606 to optimize efficiency for a wide variety of input and output voltage conditions. The device provides accurate voltage regulation over a wide load range by using a precision internal voltage reference. The EN pin can be pulled low to put the device into standby mode to reduce input quiescent current. The system undervoltage lockout can be adjusted using a resistor divider on the EN pin. A power-good signal is provided to indicate when the output is within its nominal voltage range. Thermal shutdown and current limit features protect the device during an overload condition. A 41-pin, QFN package that includes exposed bottom pads provides a thermally enhanced solution for space-constrained applications.

### 7.2 Functional Block Diagram



Copyright © 2018, Texas Instruments Incorporated

## 7.3 Feature Description

### 7.3.1 Adjusting the Output Voltage

A resistor divider connected to the FB pin (pin 15) programs the output voltage of the LMZM33606. The output voltage adjustment range is from 1 V to 20 V. [Figure 31](#) shows the feedback resistor connection for setting the output voltage. The recommended value of  $R_{FBB}$  is 10 k $\Omega$ . The value for  $R_{FBT}$  can be calculated using [Equation 1](#).

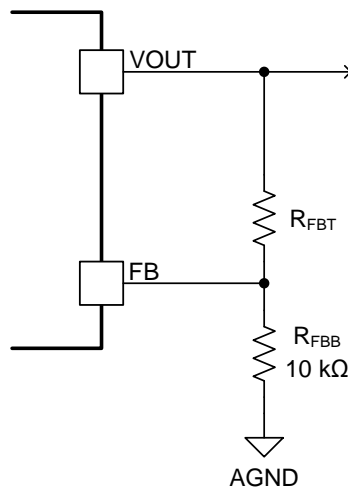
[Table 1](#) lists the standard external  $R_{FBT}$  values for several standard output voltages along with the recommended switching frequency ( $f_{SW}$ ) and the frequency setting resistor ( $R_{RT}$ ) for each of the output voltages listed. (See [Voltage Dropout](#) for the allowable output voltage as a function of input voltage.)

$$R_{FBT} = 10 \times (V_{OUT} - V_{FB}) \text{ (k}\Omega\text{)}$$

where

- $V_{FB}$  (typical) = 1.006 V

(1)



**Figure 31. Setting the Output Voltage**

**Table 1. Standard Component Values**

$V_{OUT}$ (V)	$R_{FBT}$ (k $\Omega$ ) <sup>(1)</sup>	$f_{SW}$ (kHz)	$R_{RT}$ (k $\Omega$ )
1.2	1.96	400	100
1.8	7.87	400	100
2.5	15.0	400	100
3.3	22.6	500	78.7 or open
5	40.2	500	78.7 or open
7.5	64.9	500	78.7 or open
12	110	800	47.5
15	140	800	47.5
18	169	1000	38.3
20	191	1000	38.3

(1)  $R_{FBB} = 10 \text{ k}\Omega$ .

### 7.3.2 Input Capacitor Selection

The LMZM33606 requires a minimum of 20  $\mu\text{F}$  of ceramic type input capacitance. Use only high-quality ceramic type X5R or X7R capacitors with sufficient voltage rating. TI recommends an additional 33  $\mu\text{F}$  of non-ceramic capacitance for applications with transient load requirements. The voltage rating of input capacitors must be greater than the maximum input voltage. To compensate for the derating of ceramic capacitors, TI recommends a voltage rating of twice the maximum input voltage or placing multiple capacitors in parallel. At worst case, when operating at 50% duty cycle and maximum load, the combined ripple current rating of the input capacitors must be at least 3  $A_{\text{RMS}}$ . [Table 2](#) includes a preferred list of capacitors by vendor.

**Table 2. Recommended Input Capacitors<sup>(1)</sup>**

VENDOR	SERIES	PART NUMBER	CAPACITOR CHARACTERISTICS		
			WORKING VOLTAGE (V)	CAPACITANCE <sup>(2)</sup> ( $\mu\text{F}$ )	ESR <sup>(3)</sup> ( $\text{m}\Omega$ )
TDK	X5R	C3225X5R1H106K	50	10	3
Murata	X7R	GRM32ER71H106K	50	10	2
Murata	X7R	GRM32ER71J106K	63	10	2
Panasonic	ZA	EEHZA1H101P	50	100	28
Panasonic	ZA	EEHZA1J560P	63	56	30

- (1) Consult capacitor suppliers regarding availability, material composition, RoHS and lead-free status, and manufacturing process requirements for any capacitors identified in this table.  
(2) Specified capacitance values.  
(3) Maximum ESR at 100 kHz, 25°C.

### 7.3.3 Output Capacitor Selection

The minimum amount of required output capacitance for the LMZM33606 varies depending on the output voltage. [Table 3](#) lists the minimum output capacitance for several output voltage ranges. The required output capacitance must be comprised of all ceramic capacitors.

When adding additional output capacitance, ceramic capacitors or a combination of ceramic and polymer-type capacitors can be used. The required capacitance above the minimum is determined by actual transient deviation requirements. See [Table 4](#) for a preferred list of output capacitors by vendor.

**Table 3. Minimum Required Output Capacitance**

$V_{\text{OUT}}$ RANGE (V)		MINIMUM REQUIRED $C_{\text{OUT}}$ <sup>(1)</sup>	
MIN	MAX	CAPACITANCE VALUE	VOLTAGE RATING
1	1	400 $\mu\text{F}$	$\geq 6.3 \text{ V}$
> 1	1.8	300 $\mu\text{F}$	
> 1.8	2.5	200 $\mu\text{F}$	
> 2.5	3.3	150 $\mu\text{F}$	
> 3.3	5	100 $\mu\text{F}$	
> 5.0	12	100 $\mu\text{F}$	$\geq 16 \text{ V}$
> 12	20	50 $\mu\text{F}$	$\geq 25 \text{ V}$

- (1) The minimum required output capacitance must be made up of ceramic type capacitors. Additional capacitance above the minimum can be either ceramic or low-ESR polymer type.

**Table 4. Recommended Output Capacitors<sup>(1)</sup>**

VENDOR	SERIES	PART NUMBER	CAPACITOR CHARACTERISTICS		
			VOLTAGE (V)	CAPACITANCE ( $\mu\text{F}$ ) <sup>(2)</sup>	ESR ( $\text{m}\Omega$ ) <sup>(3)</sup>
TDK	X5R	C3225X5R1C106K	16	10	2
Murata	X5R	GRM32ER61C106K	16	10	2
TDK	X5R	C3225X5R1C226M	16	22	2
Murata	X5R	GRM32ER61C226K	16	22	2
Murata	X6S	GRM31CC81E226K	25	22	2
Murata	X7R	GRM32ER71E226M	25	22	2
TDK	X5R	C3225X5R1A476M	10	47	2
Murata	X5R	GRM32ER61C476K	16	47	2
Murata	X5R	GRM31CR61E476M	25	47	2
TDK	X5R	C3225X5R0J107M	6.3	100	2
Murata	X5R	GRM32ER60J107M	6.3	100	2
Murata	X5R	GRM32ER61A107M	10	100	2
Kemet	X5R	C1210C107M4PAC7800	16	100	2
Panasonic	POSCAP	6TPF220M9L	6.3	220	9
Panasonic	POSCAP	6TPE220ML	6.3	220	12

(1) Consult capacitor suppliers regarding availability, material composition, RoHS and lead-free status, and manufacturing process requirements for any capacitors identified in this table.

(2) Specified capacitance values.

(3) Maximum ESR at 100 kHz, 25°C.

### 7.3.4 Transient Response

Table 5 shows the voltage deviation for several transient conditions.

**Table 5. Output Voltage Transient Response**

$C_{\text{IN}} = 2 \times 10 \mu\text{F}$ , 50-V Ceramic, 33 $\mu\text{F}$ , 50-V Polymer Electrolytic		
$V_{\text{OUT}}$ (V)	$C_{\text{OUT}}$	VOLTAGE <sup>(1)</sup> DEVIATION (mV)
1.8	300 $\mu\text{F}$	55
	500 $\mu\text{F}$	45
3.3	150 $\mu\text{F}$	65
	400 $\mu\text{F}$	55
5	100 $\mu\text{F}$	80
	250 $\mu\text{F}$	70
12	100 $\mu\text{F}$	260
	200 $\mu\text{F}$	220

(1) 50% load step at 1 A/ $\mu\text{s}$ .

### 7.3.5 Feed-Forward Capacitor

The LMZM33606 is internally compensated to be stable over the operating range of the device. However, depending on the output voltage and amount of output capacitance, a feed-forward capacitor,  $C_{FF}$ , may be added for optimum performance. The feed-forward capacitor should be placed in parallel with the top resistor divider,  $R_{FBT}$  as shown in Figure 32. The value for  $C_{FF}$  can be calculated using Equation 2. For output voltages < 1.2 V,  $C_{FF}$  is ineffective and is not recommended.

$$C_{FF} = 4.3 \times \frac{V_{OUT} \times C_{OUT}}{R_{FBT}} \quad (\text{pF})$$

where

- $C_{OUT}$  is in  $\mu\text{F}$
- $R_{FBT}$  is in  $\text{k}\Omega$

(2)

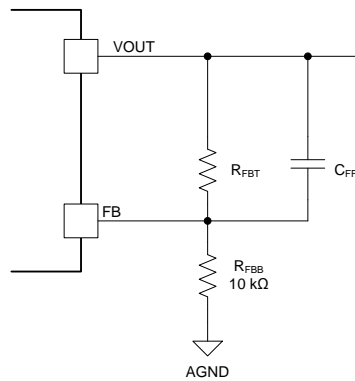


Figure 32. Feed-Forward Capacitor

### 7.3.6 Switching Frequency (RT)

The recommended switching frequency range of the LMZM33606 is 350 kHz to 1.2 MHz. Table 6 shows the allowable output voltage range for several switching frequency settings for three common input voltages. Under some operating conditions, the device can operate at higher switching frequencies (up to 2.2 MHz), however, this will reduce efficiency and thermal performance. The switching frequency can easily be set by connecting a resistor ( $R_{RT}$ ) between the RT pin and AGND. Additionally, the RT pin can be left floating, and the LMZM33606 operates at 500 kHz default switching frequency. Use Equation 3 to calculate the  $R_{RT}$  value for a desired frequency or simply select from Table 6.

The switching frequency must be selected based on the output voltage setting of the device. See Table 6 for  $R_{RT}$  values and the allowable output voltage range at a given switching frequency for several common input voltages. For the most efficient solution, always select the lowest allowable frequency.

$$R_{RT} = \frac{1}{f_{sw}(\text{kHz}) \times (2.675 \times 10^{-5}) - 0.0007} \quad (\text{k}\Omega) \quad (3)$$

**Table 6. Switching Frequency vs Output Voltage**

SWITCHING FREQUENCY (kHz)	$R_{RT}$ RESISTOR (k $\Omega$ )	$V_{IN} = 5 \text{ V } (\pm 10\%)$		$V_{IN} = 12 \text{ V } (\pm 10\%)$		$V_{IN} = 24 \text{ V } (\pm 10\%)$	
		$V_{OUT}$ RANGE (V)		$V_{OUT}$ RANGE (V)		$V_{OUT}$ RANGE (V)	
		MIN	MAX	MIN	MAX	MIN	MAX
350	115	1	4	1	8.2	1	8.4
400	100	1	4	1	8.8	1	9.9
500	78.7 or open	1	4	1	9.9	1.1	13.9
600	64.9	1	4	1	9.9	1.3	15.6
700	54.9	1	3.5	1	9.7	1.5	16.9
800	47.5	1	3.4	1	9.6	1.7	18
1000	38.3	1	3.4	1.1	9.3	2.1	20
1200	31.6	1	3.3	1.3	9.1	2.5	19.1
1500	25.5	1	2.9	1.8	8.1	3.2	18.1
1800	21.0	1.1	2.7	2.1	7.7	3.9	17.2
2000	19.1	1.2	2.5	2.5	7.5	4.4	16.5
2200	17.4	1.3	2.4	2.7	7.2	4.8	15.9

### 7.3.7 Synchronization (SYNC/MODE)

The LMZM33606 switching frequency can also be synchronized to an external clock from 350 kHz to 2.2 MHz. Before the external clock is present, the device switches at the frequency programmed by the  $R_{RT}$  resistor. Select  $R_{RT}$  to set the frequency to be the same as the external synchronization frequency. Once the external clock is present, the device transitions to SYNC mode within 1 ms (typical) and overrides the RT mode. If the external clock is removed, the device continues to switch at the SYNC frequency for 10  $\mu$ s (typ) before returning to the switching frequency set by the RT resistor, resulting in minimal disturbance to the output voltage during the transitions.

Recommendations for the external clock include a high level no lower than 2 V, low level no higher than 0.4 V, duty cycle between 10% and 90%, and both positive and negative pulse width no shorter than 80 ns.

When synchronizing to an external clock, the device operation mode is FPWM. If synchronization is not needed, connect this pin to AGND or logic high to select either Auto mode or FPWM mode. Do not leave this pin open.

The synchronization frequency must be selected based on the output voltages of the devices being synchronized. Table 6 and show the allowable frequencies for a given range of output voltages. For the most efficient solution, always select the lowest allowable frequency.

### 7.3.8 Output Enable (EN)

The voltage on the EN pin provides electrical ON/OFF control of the device. Once the EN pin voltage exceeds the threshold voltage, the device starts operation. If the EN pin voltage is pulled below the threshold voltage, the regulator stops switching and enters low quiescent current state.

The EN pin cannot be open circuit or floating. The simplest way to enable the operation of the LMZM33606 is to connect the EN pin to VIN directly as shown in Figure 33. This allows self-start-up of the LMZM33606 when VIN reaches the turn-on threshold.

If an application requires controlling the EN pin, an external logic signal can be used to drive EN pin as shown in Figure 34. Applications using an open drain/collector device to interface with this pin require a pull-up resistor to a voltage above the enable threshold.

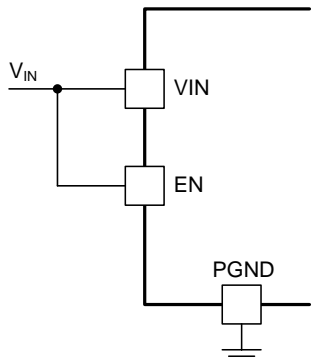


Figure 33. Enabling the Device

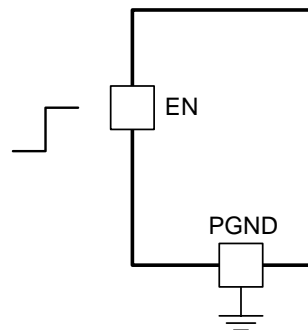


Figure 34. Typical Enable Control

### 7.3.9 Programmable System UVLO (EN)

Many applications benefit from employing an enable divider to establish a customized system UVLO. This can be used for sequencing, to satisfy a system timing requirement, or to reduce the occurrence of deep discharge of a battery power source. Figure 35 shows how to use a resistor divider to set a system UVLO level. An external logic output can also be used to drive the EN pin for system sequencing.

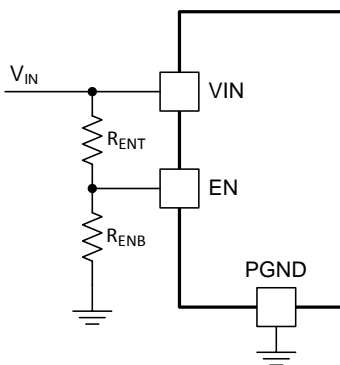


Figure 35. System UVLO

Table 7 lists recommended resistor values for  $R_{ENT}$  and  $R_{ENB}$  to adjust the system UVLO voltage. TI recommends to set the system UVLO turn-on threshold to approximately 80% to 85% of the minimum expected input voltage.

Table 7. Resistor Values for Setting System UVLO

UVLO (V)	6.5	10	15	20	25
$R_{ENT}$ (k $\Omega$ )	100	100	100	100	100
$R_{ENB}$ (k $\Omega$ )	22.6	13.7	8.66	6.34	4.99

### 7.3.10 Internal LDO and BIAS\_SEL

The LMZM33606 integrates an internal LDO, generating a typical  $V_{CC}$  voltage (3.27 V) for control circuitry and MOSFET drivers. The LDO generates  $V_{CC}$  voltage from  $V_{IN}$  unless a sufficient bias voltage,  $V_{BIAS}$ , is applied to BIAS\_SEL pin. The BIAS\_SEL input provides an option to supply the LDO with a lower voltage than  $V_{IN}$  to reduce the LDO power loss. The smaller the difference between the input applied to the LDO,  $V_{IN\_LDO}$ , and the LDO output voltage,  $V_{CC}$ , the more efficiently the device will perform. The amount of current supplied through the LDO will change based on operating conditions. Figure 36 demonstrates the typical LDO current,  $I_{LDO}$ , for common input voltages over the recommended switching frequency range.

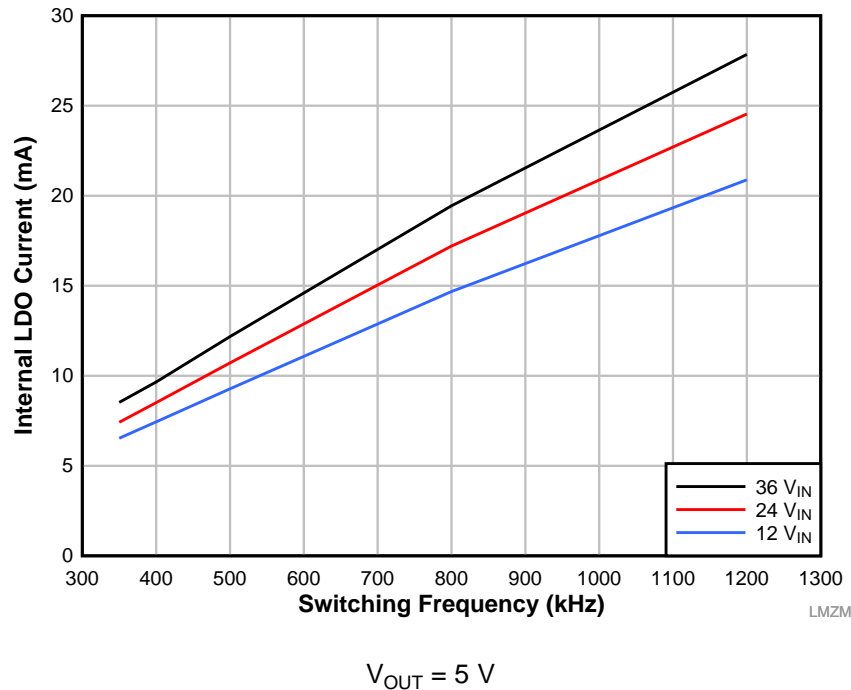


Figure 36. LDO Current vs Switching Frequency

The amount of power loss in the LDO can be calculated by Equation 4.

$$P_{LOSS\_LDO} = I_{LDO} \times (V_{IN\_LDO} - V_{CC}) \tag{4}$$

For example, when the device is operating at  $V_{IN} = 24\text{ V}$ ,  $V_{OUT} = 5\text{ V}$ ,  $f_{sw} = 500\text{ kHz}$ , BIAS\_SEL = PGND, the  $I_{LDO}$  is typical 11 mA, therefore, the  $P_{LOSS\_LDO} = 11\text{ mA} \times (24\text{ V} - 3.27\text{ V}) = 228.03\text{ mW}$ . For the same operating conditions with BIAS\_SEL = 5 V, the power loss is equal to  $11\text{ mA} \times (5\text{ V} - 3.27\text{ V}) = 19.03\text{ mW}$ . The benefits of applying a bias voltage to reduce power loss are most notable in applications when  $V_{IN} \gg V_{CC}$  or when the device is operating at a higher switching frequency. The power savings can be calculated by Equation 5.

$$\text{Power Savings} = I_{LDO} \times (V_{IN} - V_{BIAS\_SEL}) \tag{5}$$

Figure 37 and Figure 38 show efficiency plots of the LMZM33606 operating with different source voltages applied to the BIAS\_SEL pin. Figure 39 demonstrates the power dissipation of the device with various source voltages at BIAS\_SEL pin. The plots include BIAS\_SEL tied to a 3.3 V external bias, 5 V external bias, VOUT (5 V) and no bias voltage applied. The efficiency improvements are more significant when the device is operating at light loads because the LDO loss is a higher percentage of the total loss.

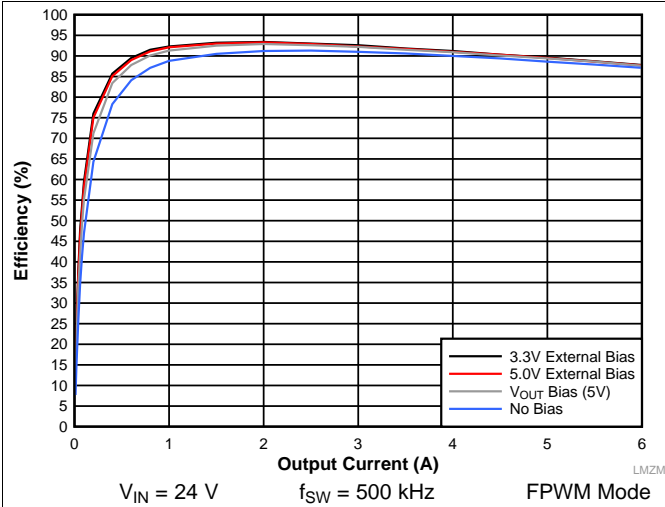


Figure 37. Efficiency Comparison with BIAS\_SEL vs Output Current

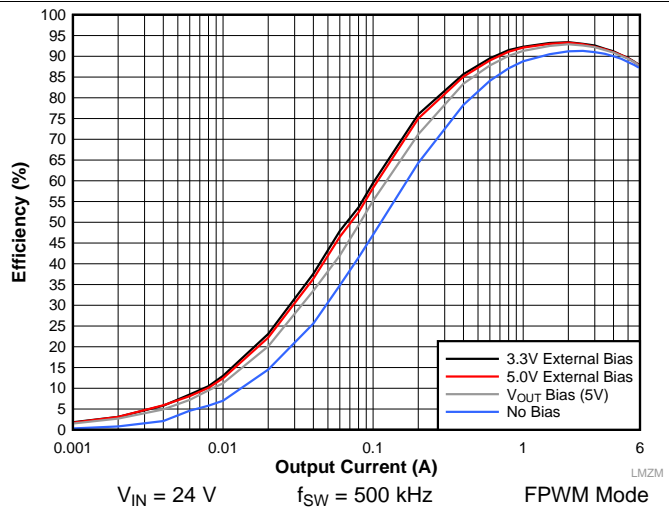


Figure 38. Efficiency Comparison with BIAS\_SEL vs Output Current

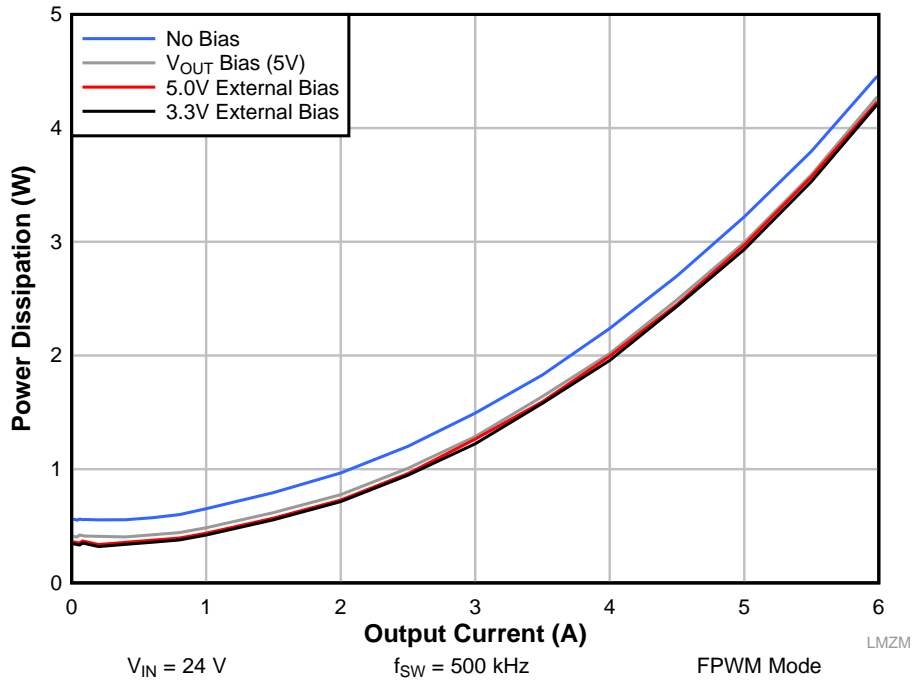


Figure 39. Power Dissipation Comparison with BIAS\_SEL

### 7.3.11 Power Good (PGOOD) and Power Good Pull-Up (PGOOD\_PU)

The LMZM33606 has a built-in power-good signal (PGOOD) that indicates whether the output voltage is within its regulation range. The PGOOD pin is an open-drain output that requires a pull-up resistor to a nominal voltage source of 15 V or less. The maximum recommended PGOOD sink current is 5 mA. A typical pull-up resistor value is between 10 kΩ and 100 kΩ.

Once the output voltage rises above 90% (typical) of the set voltage, the PGOOD pin rises to the pull-up voltage level. The PGOOD pin is pulled low when the output voltage drops lower than 90% (typical) or rises higher than 110% (typ) of the nominal set voltage.

Internal to the device, a 100-kΩ pull-up resistor is placed between the PGOOD pin and the PGOOD\_PU pin. Applying a pull-up voltage directly to the PGOOD\_PU pin, eliminates the need for an external pull-up resistor.

### 7.3.12 Mode Select (Auto or FPWM)

The LMZM33606 has configurable Auto mode or FPWM mode options. To select Auto mode, connect the SYNC/MODE pin (pin 19) to AGND, or a logic signal lower than 0.3 V. To select FPWM mode, connect the SYNC/MODE pin to a bias voltage or logic signal greater than 0.6 V. When synchronizing to an external clock, the device inherently operates in FPWM mode.

In Auto mode, the device operates in discontinuous conduction mode (DCM) at light loads. In DCM, the inductor current stops flowing when it reaches 0 A. Additionally, at very light loads, the switching frequency reduces (PFM operation) to regulate the required load current, thus improving efficiency by reducing switching losses. At heavier loads, when the inductor current valley is above 0 A, the device operates in continuous conduction mode (CCM), where the switching frequency is fixed and set by the RT pin.

In forced PWM (FPWM) mode, the device operates in CCM (at a fixed frequency) regardless of load. In this mode, inductor current can go negative. At light loads, the efficiency in FPWM mode is lower than in Auto mode, due to higher conduction losses and higher switching losses. The fact that the switching frequency is fixed over the entire load range is beneficial in noise sensitive applications.

### 7.3.13 Soft Start and Voltage Tracking

The soft-start and tracking features control the output voltage ramp during start-up. The soft-start feature reduces inrush current during start-up and improves system performance and reliability. If the SS/TRK pin is floating, the LMZM33606 starts up following the fixed, 5-ms internal soft-start ramp. Use  $C_{SS}$  to extend soft-start time when there are a large amount of output capacitors, or the output voltage is high, or the output is heavily loaded during start-up.

If longer soft-start time is desired, an external capacitor can be added from SS/TRK pin to AGND. There is a 2 μA (typical) internal current source,  $I_{SSC}$ , to charge the external capacitor. For a desired soft-start time  $t_{SS}$ , capacitance of  $C_{SS}$  can be found by [Equation 6](#).

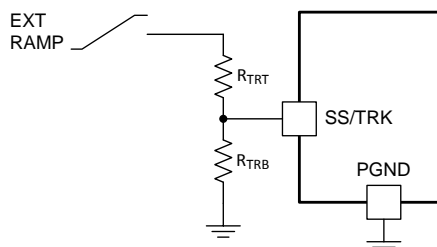
$$C_{SS} = I_{SSC} \times t_{SS}$$

where

- $C_{SS}$  = soft-start capacitor value (F)
- $I_{SSC}$  = soft-start charging current (A)
- $t_{SS}$  = desired soft-start time(s)

(6)

LMZM33606 can track an external voltage ramp applied to the SS/TRK pin, if the ramp is slower than the internal soft-start ramp. The external ramp final voltage after start-up must be greater than 1.5 V to avoid noise interfering with the reference voltage. [Figure 40](#) shows how to use resistor divider to set  $V_{OUT}$  to follow an external ramp.



**Figure 40. Soft-Start Tracking External Ramp**

### 7.3.14 Voltage Dropout

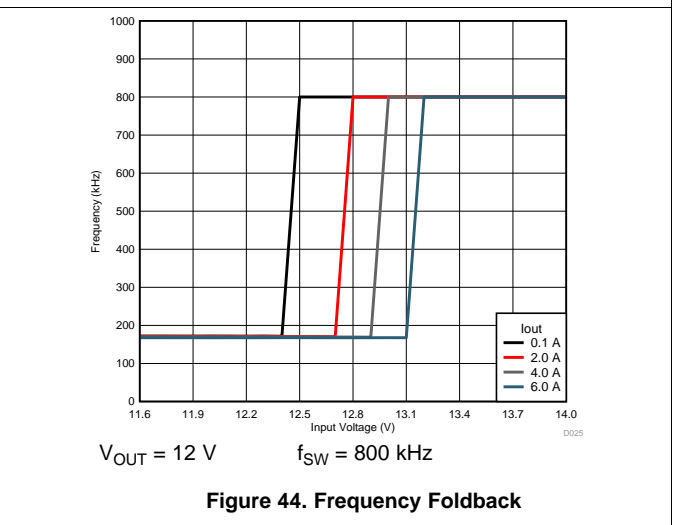
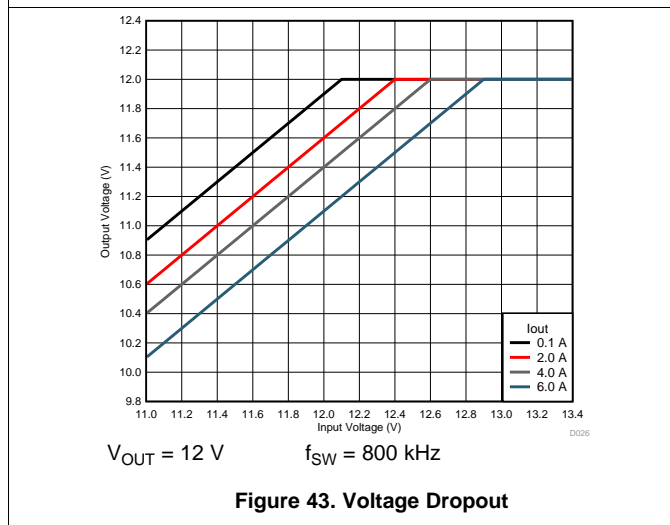
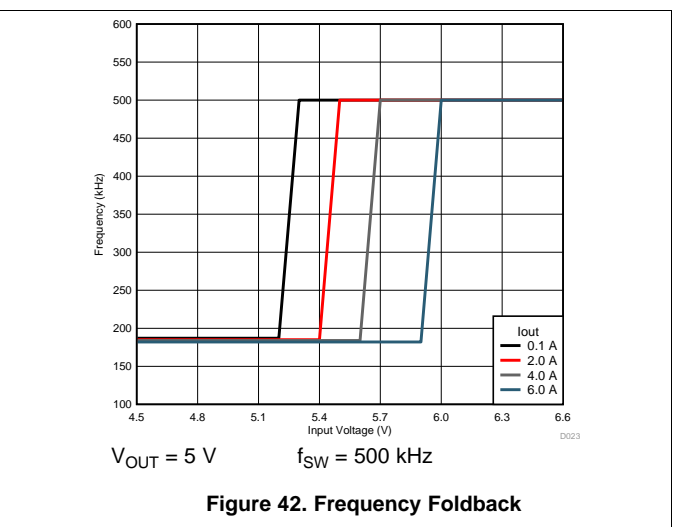
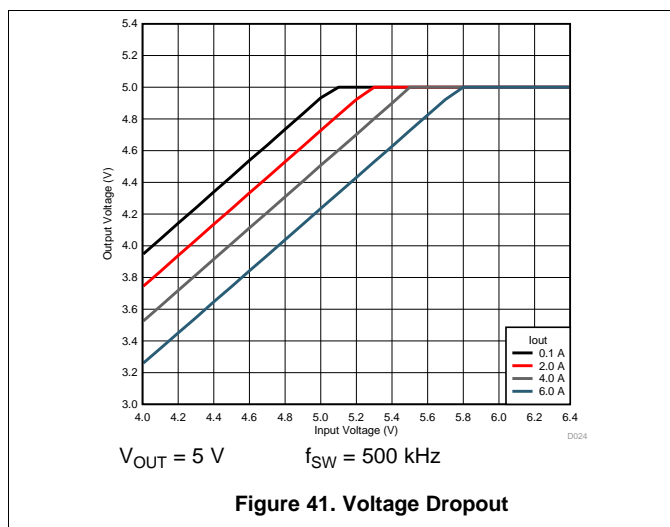
Voltage dropout is the minimum difference between the input voltage and output voltage that is required to maintain output voltage regulation while providing the rated output current.

To ensure the LMZM33606 maintains output voltage regulation at the recommended switching frequency, over the operating temperature range, the following requirements apply:

For output voltages  $\leq 5$  V, the minimum  $V_{IN}$  is 3.5 V or  $(V_{OUT} + 1$  V), whichever is greater.

For output voltages  $> 5$  V, the minimum  $V_{IN}$  is  $(1.1 \times V_{OUT})$ .

However, if fixed switching frequency operation is not required, the LMZM33606 operates in a frequency foldback mode when the dropout voltage is less than the recommendations above. Frequency foldback reduces the switching frequency to allow the output voltage to maintain regulation as input voltage decreases. Figure 41 through Figure 44 show typical dropout voltage and frequency foldback curves for 5 V and 12 V outputs at  $T_A = 25^\circ\text{C}$ . (As ambient temperature increases, dropout voltage and frequency foldback occur at higher input voltages.)



### 7.3.15 Overcurrent Protection (OCP)

The LMZM33606 is protected from overcurrent conditions. Hiccup mode is activated if a fault condition persists to prevent overheating. In hiccup mode, the regulator is shut down and kept off for 10 ms (typical) before the LMZM33606 tries to start again. If an overcurrent or short-circuit fault condition still exists, hiccup repeats until the fault condition is removed. Hiccup mode reduces power dissipation under severe overcurrent conditions and prevents overheating and potential damage to the device. Once the fault is removed, the module automatically recovers and returns to normal operation.

### 7.3.16 Thermal Shutdown

The internal thermal shutdown circuitry forces the device to stop switching if the junction temperature exceeds 160°C (typical). The device reinitiates the power-up sequence when the junction temperature drops below 135°C (typical).

## 7.4 Device Functional Modes

### 7.4.1 Active Mode

The LMZM33606 is in active mode when VIN is above the turn-on threshold and the EN pin voltage is above the EN high threshold. The simplest way to enable the LMZM33606 is to connect the EN pin to VIN. This allows self start-up of the LMZM33606 when the input voltage is in the operation range of 3.5 V to 36 V.

### 7.4.2 Auto Mode

In Auto mode, the LMZM33606 operates in discontinuous conduction mode (DCM) at light loads. In DCM, the inductor current stops flowing when it reaches 0 A. Additionally, at very light loads, the switching frequency reduces (PFM operation) to regulate the required load current, thus improving efficiency by reducing switching losses. At heavier loads, when the inductor current valley is above 0 A, the device operates in continuous conduction mode (CCM), where the switching frequency is fixed and set by the RT pin.

### 7.4.3 FPWM Mode

In forced PWM (FPWM) mode, the LMZM33606 operates in CCM (at a fixed frequency) regardless of load. In this mode, inductor current can go negative. At light loads, the efficiency in FPWM mode is lower than in Auto mode, due to higher conduction losses and higher switching losses.

### 7.4.4 Shutdown Mode

The EN pin provides electrical ON and OFF control for the LMZM33606. When the EN pin voltage is below the EN low threshold, the device is in shutdown mode. In shutdown mode the standby current is 0.8  $\mu$ A typical. If  $V_{IN}$  falls below the turn-off threshold, the output of the regulator is turned off.

## 8 Application and Implementation

### NOTE

Information in the following applications sections is not part of the TI component specification, and TI does not warrant its accuracy or completeness. TI's customers are responsible for determining suitability of components for their purposes. Customers should validate and test their design implementation to confirm system functionality.

### 8.1 Application Information

The LMZM33606 is a synchronous, step-down, DC/DC power module. It is used to convert a higher DC voltage to a lower DC voltage with a maximum output current of 6 A. The following design procedure can be used to select components for the LMZM33606. Alternately, the WEBENCH® software may be used to generate complete designs. When generating a design, the WEBENCH® software utilizes an iterative design procedure and accesses comprehensive databases of components. See [www.ti.com](http://www.ti.com) for more details.

### 8.2 Typical Application

The LMZM33606 only requires a few external components to convert from a wide input-voltage-supply range to a wide range of output voltages. Figure 45 shows a typical LMZM33606 schematic.

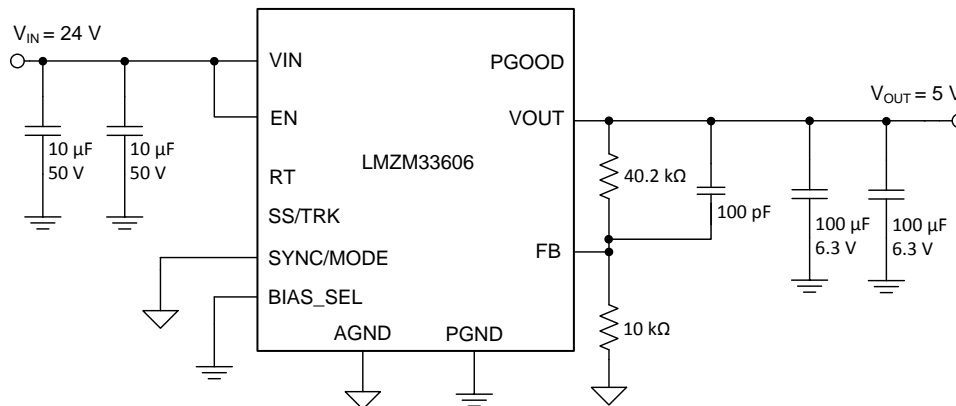


Figure 45. LMZM33606 Typical Schematic

#### 8.2.1 Design Requirements

For this design example, use the parameters listed in Table 8 as the input parameters and follow the design procedures in [Detailed Design Procedure](#).

Table 8. Design Example Parameters

DESIGN PARAMETER	VALUE
Input voltage $V_{IN}$	24 V typical
Output voltage $V_{OUT}$	5 V
Output current rating	6 A
Operating frequency	500 kHz

## 8.2.2 Detailed Design Procedure

### 8.2.2.1 Output Voltage Setpoint

The output voltage of the LMZM33606 device is externally adjustable using a resistor divider. The recommended value of  $R_{FBB}$  is 10 k $\Omega$ . The value for  $R_{FBT}$  can be selected from [Table 1](#) or calculated using the [Equation 7](#):

$$R_{FBT} = 10 \times (V_{OUT} - V_{FB}) \text{ (k}\Omega\text{)} \tag{7}$$

For the desired output voltage of 5 V, the formula yields a value of 40 k $\Omega$ . Choose the closest available value of 40.2 k $\Omega$  for  $R_{FBT}$ .

### 8.2.2.2 Setting the Switching Frequency

The recommended switching frequency for a 5-V application is 500 kHz. To set the switching frequency to 500 kHz, the RT pin can be left open to operate at the default 500-kHz switching frequency.

### 8.2.2.3 Input Capacitors

The LMZM33606 requires a minimum input capacitance of 20- $\mu$ F ceramic type. High-quality ceramic type X5R or X7R capacitors with sufficient voltage rating are recommended. The voltage rating of input capacitors must be greater than the maximum input voltage.

For this design, 2x 10- $\mu$ F, 50-V ceramic capacitors are selected.

### 8.2.2.4 Output Capacitor Selection

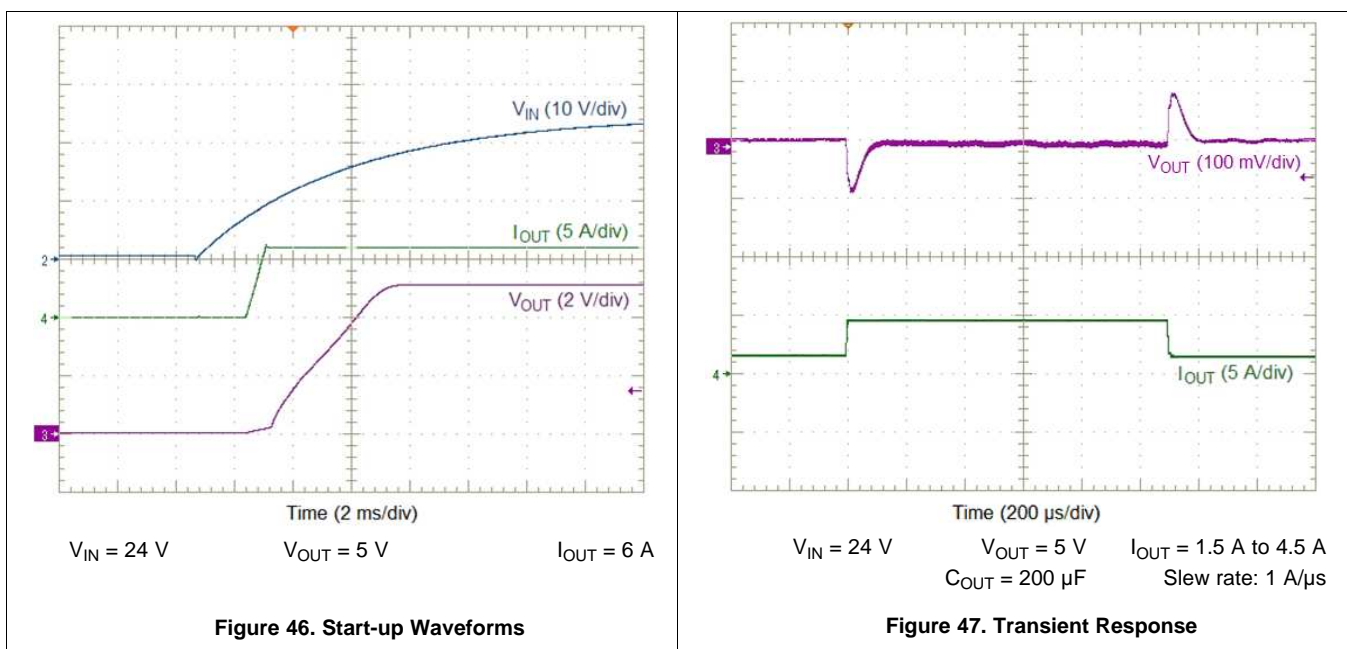
The LMZM33606 requires a minimum amount of output capacitance for proper operation. The minimum amount of required output varies depending on the output voltage. See [Table 3](#) for the required output capacitance.

For this design example, 2 x 100- $\mu$ F, 6.3-V ceramic capacitors are used.

### 8.2.2.5 Feed-Forward Capacitor ( $C_{FF}$ )

For typical applications, an external feed-forward capacitor,  $C_{FF}$  is not required. Applications requiring optimum transient performance can benefit from placing a  $C_{FF}$  capacitor in parallel with the top resistor divider,  $R_{FBT}$ . The value for  $C_{FF}$  can be calculated using [Equation 2](#). The recommended  $C_{FF}$  value for 5-V application is 100 pF.

### 8.2.2.6 Application Curves



## 9 Power Supply Recommendations

The LMZM33606 is designed to operate from an input voltage supply range between 3.5 V and 36 V. This input supply must be able to withstand maximum input current and maintain a stable voltage. The resistance of the input supply rail must be low enough that an input current transient does not cause a high enough drop at the LMZM33606 supply voltage that can cause a turn-off and system reset.

If the input supply is located more than a few inches from the LMZM33606 additional bulk capacitance may be required in addition to the ceramic bypass capacitors. The typical amount of bulk capacitance is a 100- $\mu$ F electrolytic capacitor.

## 10 Layout

The performance of any switching power supply depends as much upon the layout of the PCB as the component selection. Use the following guidelines to design a PCB with the best power conversion performance, optimal thermal performance, and minimal generation of unwanted EMI.

### 10.1 Layout Guidelines

To achieve optimal electrical and thermal performance, an optimized PCB layout is required. [Figure 48](#) thru [Figure 51](#), shows a typical PCB layout. Some considerations for an optimized layout are:

- Use large copper areas for power planes (VIN, VOUT, and PGND) to minimize conduction loss and thermal stress.
- **Connect all PGND pins together using copper plane or thick copper traces.**
- Connect the SW pins together using a small copper island under the device for thermal relief.
- Place ceramic input and output capacitors close to the device pins to minimize high frequency noise.
- Locate additional output capacitors between the ceramic capacitor and the load.
- Keep AGND and PGND separate from one another. AGND and PGND are connected internal to the device.
- Place  $R_{FBT}$ ,  $R_{FBB}$ ,  $R_{RT}$ , and  $C_{FF}$  as close as possible to their respective pins.
- Use multiple vias to connect the power planes to internal layers.

## 10.2 Layout Example

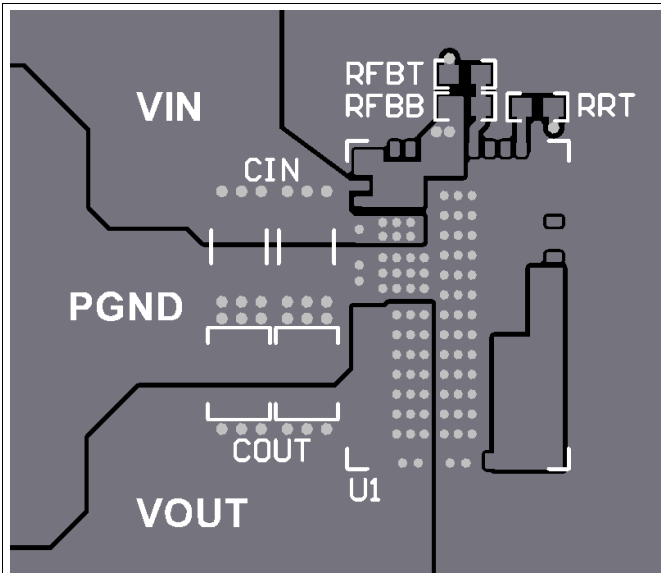


Figure 48. Typical Top-Layer Layout

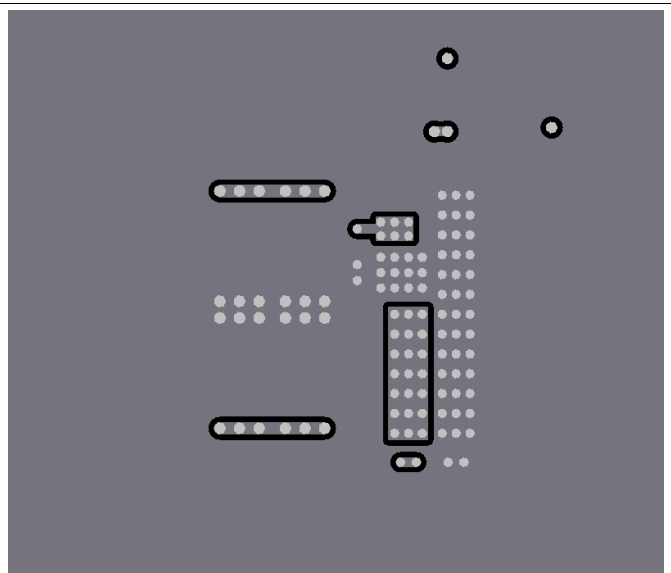


Figure 49. Typical Layer-2 Layout

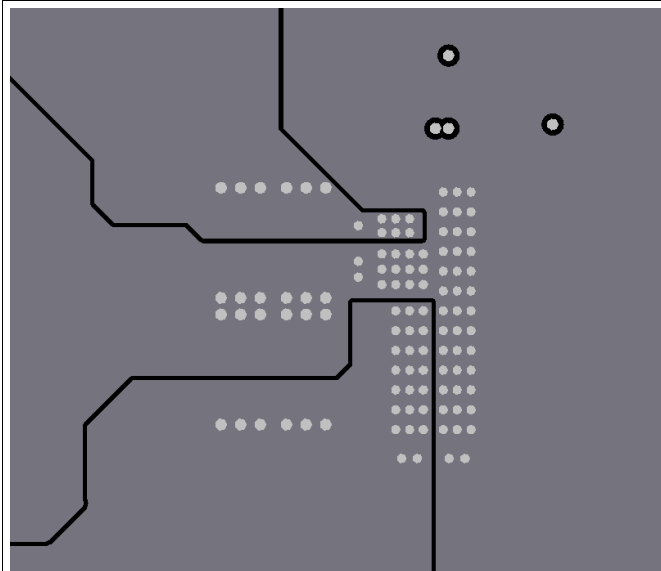


Figure 50. Typical Layer 3 Layout

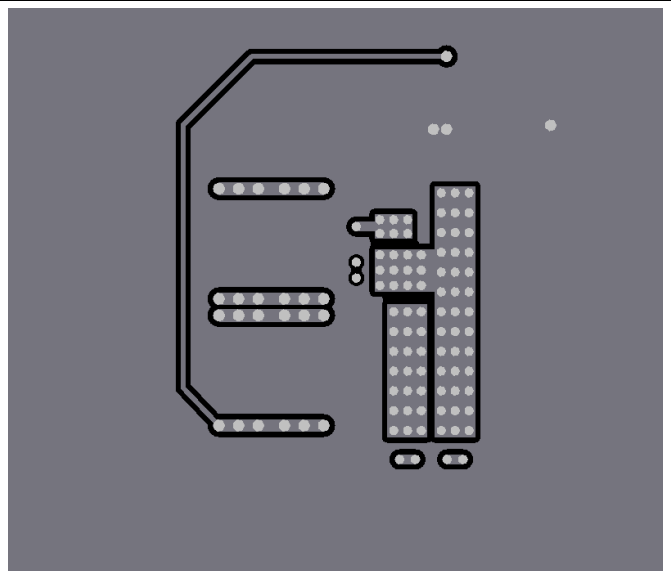


Figure 51. Typical Bottom-Layer Layout

### 10.3 Theta JA vs PCB Area

The amount of PCB copper effects the thermal performance of the device. Figure 52 shows the effects of copper area on the junction-to-ambient thermal resistance ( $R_{\theta JA}$ ) of the LMZM33606. The junction-to-ambient thermal resistance is plotted for a 4-layer PCB and a 6-layer PCB with PCB area from 16 cm<sup>2</sup> to 100 cm<sup>2</sup>.

To determine the required copper area for an application:

1. Determine the maximum power dissipation of the device in the application by referencing the power dissipation graphs in the *Typical Characteristics* section.
2. Calculate the maximum  $\theta_{JA}$  using Equation 8 and the maximum ambient temperature of the application.

$$\theta_{JA} = \frac{(125^{\circ}\text{C} - T_{A(\text{max})})}{P_{D(\text{max})}} \quad (^{\circ}\text{C}/\text{W}) \tag{8}$$

3. Reference Figure 52 to determine the minimum required PCB area for the application conditions.

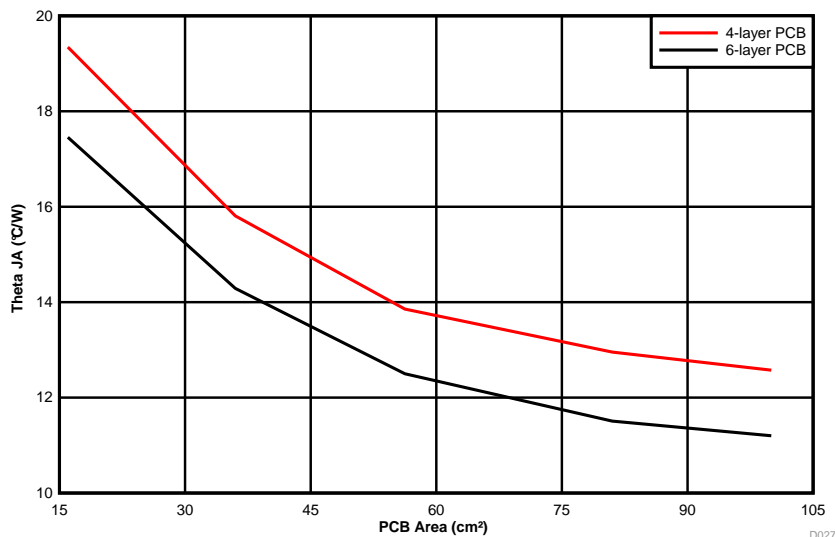


Figure 52.  $\theta_{JA}$  vs PCB Area

### 10.4 Package Specifications

Table 9. Package Specifications Table

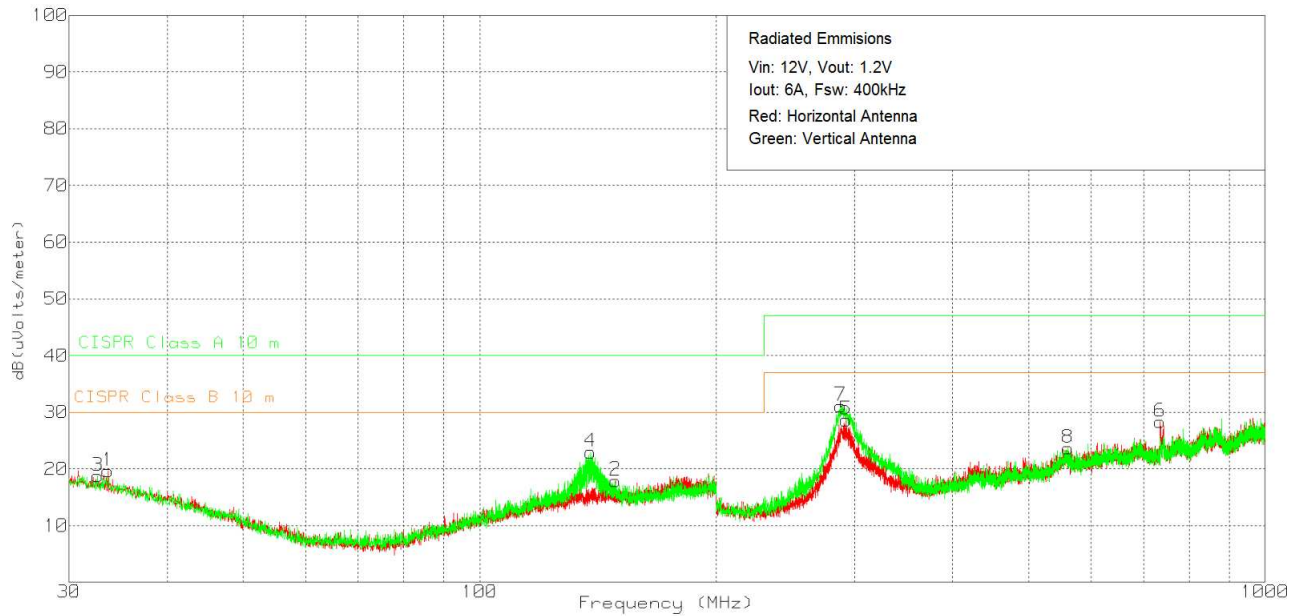
LMZM33606		VALUE	UNIT
Weight		2.0	grams
Flammability	Meets UL 94 V-O		
MTBF Calculated Reliability	Per Bellcore TR-332, 50% stress, $T_A = 40^{\circ}\text{C}$ , ground benign	85.5	MHrs

## 10.5 EMI

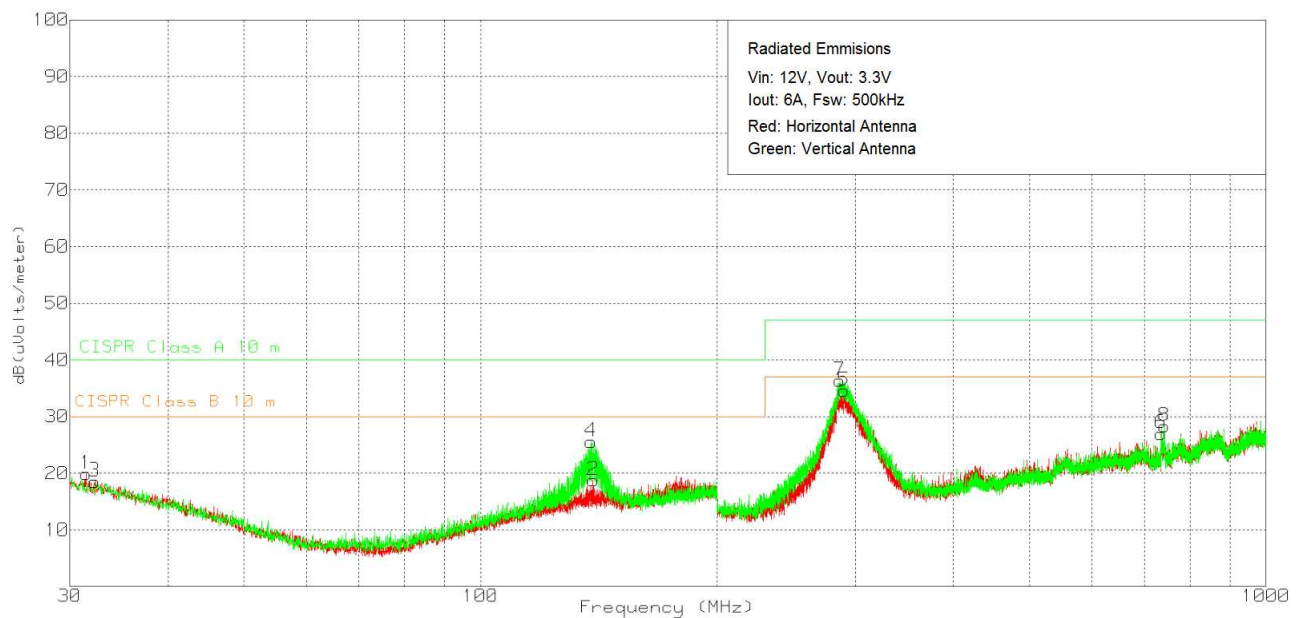
The LMZM33606 is compliant with EN55011 radiated emissions. [Figure 53](#), [Figure 54](#), and [Figure 55](#) show typical examples of radiated emissions plots for the LMZM33606. The graphs include the plots of the antenna in the horizontal and vertical positions.

### 10.5.1 EMI Plots

EMI plots were measured using the standard LMZM33606EVM with no input filter.

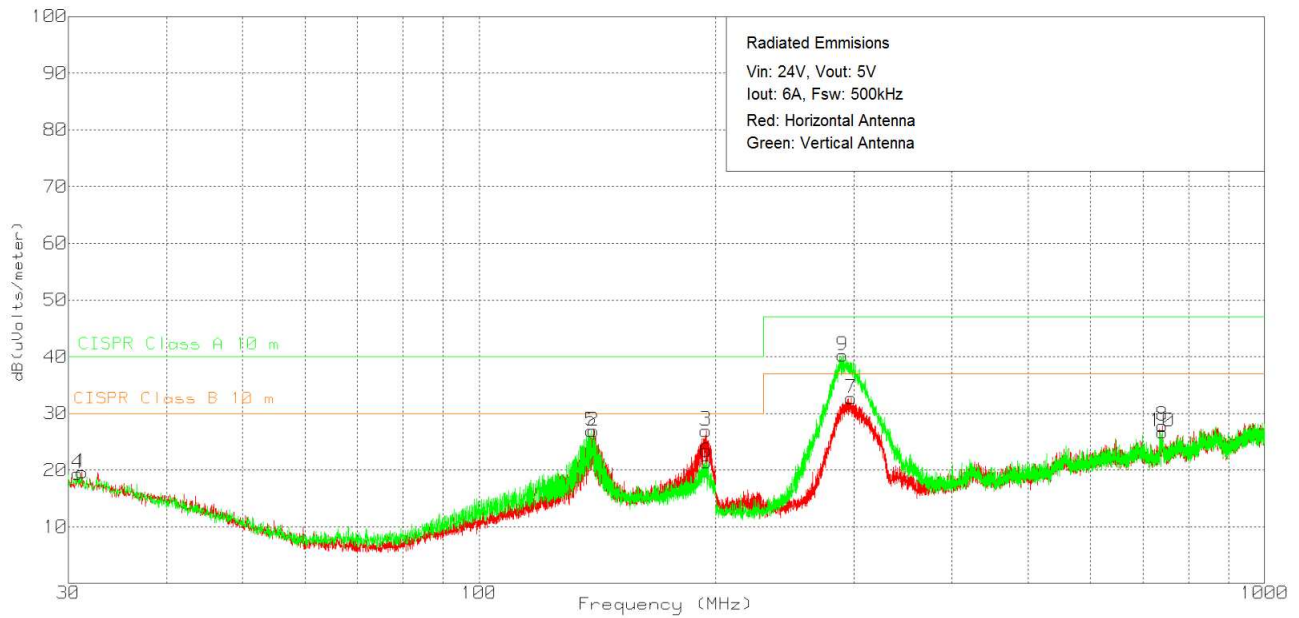


**Figure 53. Radiated Emissions 12-V Input, 1.2-V Output, 6-A Load**

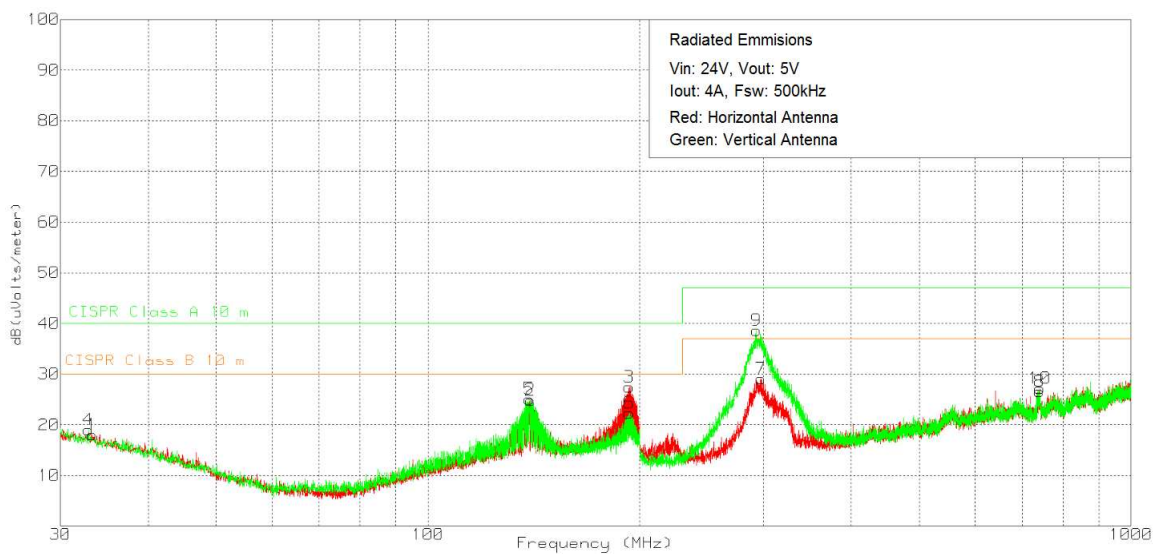


**Figure 54. Radiated Emissions 12-V Input, 3.3-V Output, 6-A Load**

**EMI (continued)**



**Figure 55. Radiated Emissions 24-V Input, 5-V Output, 6-A Load**



**Figure 56. Radiated Emissions 24-V Input, 5-V Output, 4-A Load**

## 11 Device and Documentation Support

### 11.1 Device Support

#### 11.1.1 Third-Party Products Disclaimer

TI'S PUBLICATION OF INFORMATION REGARDING THIRD-PARTY PRODUCTS OR SERVICES DOES NOT CONSTITUTE AN ENDORSEMENT REGARDING THE SUITABILITY OF SUCH PRODUCTS OR SERVICES OR A WARRANTY, REPRESENTATION OR ENDORSEMENT OF SUCH PRODUCTS OR SERVICES, EITHER ALONE OR IN COMBINATION WITH ANY TI PRODUCT OR SERVICE.

#### 11.2 Receiving Notification of Documentation Updates

To receive notification of documentation updates, navigate to the device product folder on ti.com. In the upper right corner, click on *Alert me* to register and receive a weekly digest of any product information that has changed. For change details, review the revision history included in any revised document.

#### 11.3 Community Resources

The following links connect to TI community resources. Linked contents are provided "AS IS" by the respective contributors. They do not constitute TI specifications and do not necessarily reflect TI's views; see TI's [Terms of Use](#).

**TI E2E™ Online Community** *TI's Engineer-to-Engineer (E2E) Community*. Created to foster collaboration among engineers. At e2e.ti.com, you can ask questions, share knowledge, explore ideas and help solve problems with fellow engineers.

**Design Support** *TI's Design Support* Quickly find helpful E2E forums along with design support tools and contact information for technical support.

#### 11.4 Trademarks

E2E is a trademark of Texas Instruments.  
All other trademarks are the property of their respective owners.

#### 11.5 Electrostatic Discharge Caution



These devices have limited built-in ESD protection. The leads should be shorted together or the device placed in conductive foam during storage or handling to prevent electrostatic damage to the MOS gates.

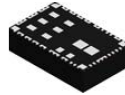
#### 11.6 Glossary

[SLYZ022](#) — *TI Glossary*.

This glossary lists and explains terms, acronyms, and definitions.

## 12 Mechanical, Packaging, and Orderable Information

The following pages include mechanical packaging and orderable information. This information is the most current data available for the designated devices. This data is subject to change without notice and revision of this document. For browser-based versions of this data sheet, refer to the left-hand navigation.

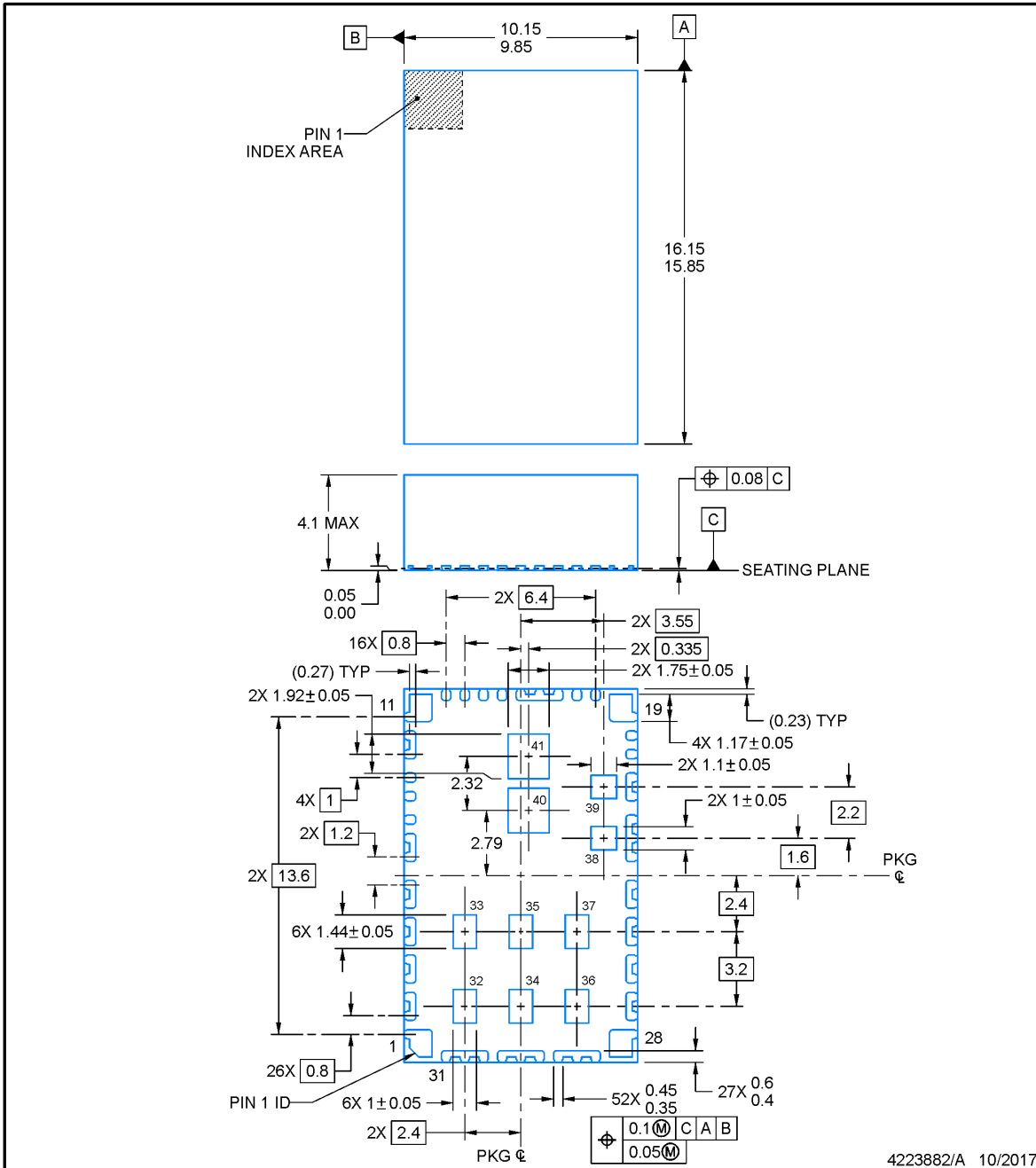


PACKAGE OUTLINE

RLX0041A

B3QFN - 4.1 mm max height

PLASTIC QUAD FLATPACK - NO LEAD



NOTES:

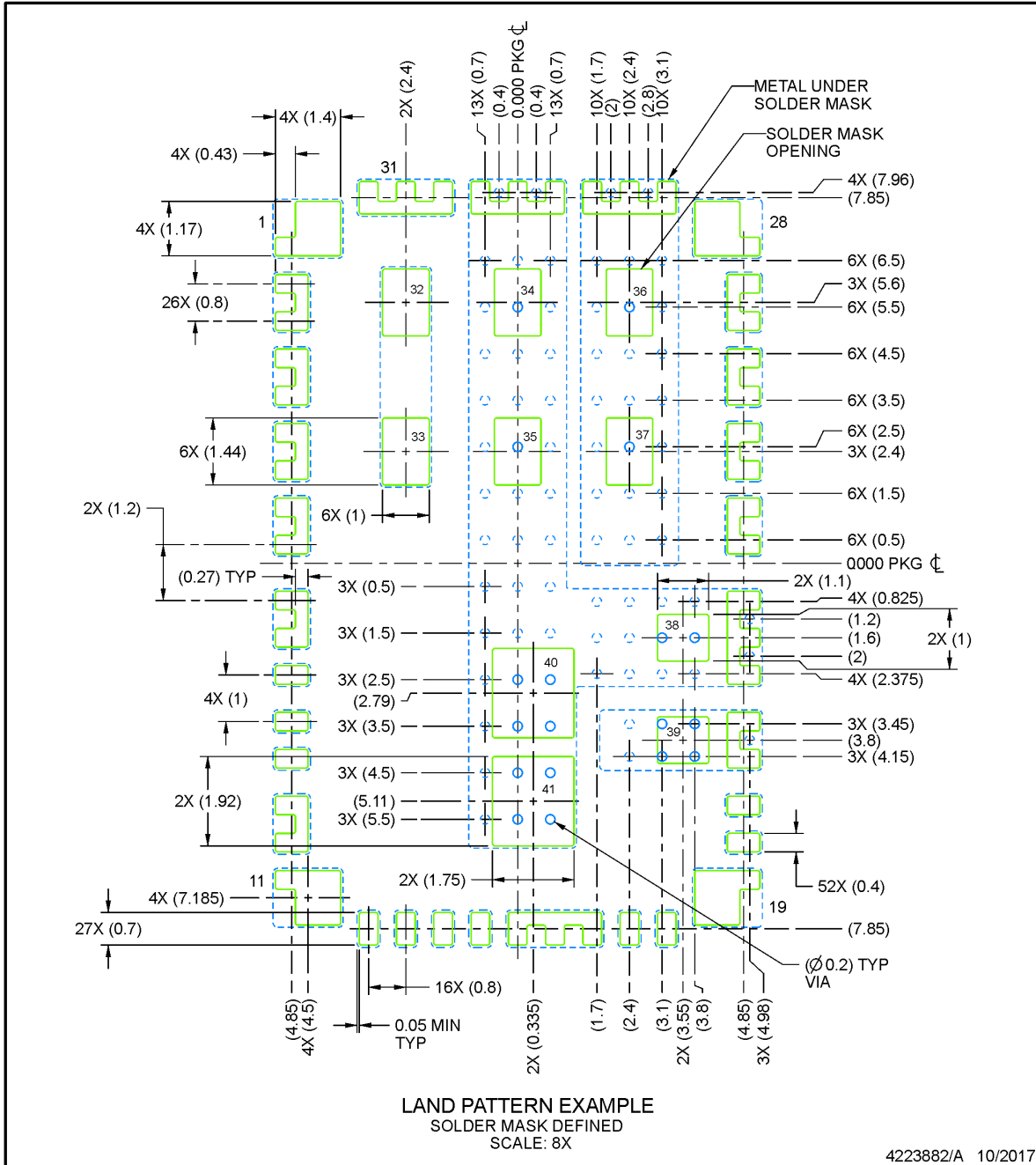
1. All linear dimensions are in millimeters. Any dimensions in parenthesis are for reference only. Dimensioning and tolerancing per ASME Y14.5M.
2. This drawing is subject to change without notice.
3. The package thermal pads must be soldered to the printed circuit board for optimal thermal and mechanical performance.

EXAMPLE BOARD LAYOUT

RLX0041A

B3QFN - 4.1 mm max height

PLASTIC QUAD FLATPACK - NO LEAD



NOTES: (continued)

- This package designed to be soldered to a thermal pads on the board. For more information, see Texas Instruments literature number SLUA271 ([www.ti.com/lit/slua271](http://www.ti.com/lit/slua271)).
- Vias are optional depending on application, refer to device data sheet. If any vias are implemented, refer to their locations shown on this view. It is recommended that vias under paste be filled, plugged or tented.

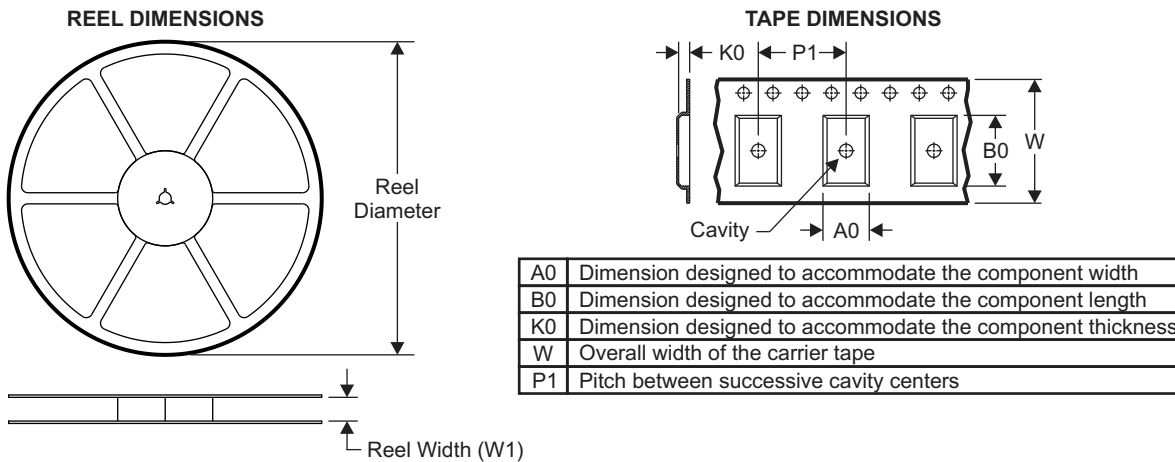


# LMZM33606

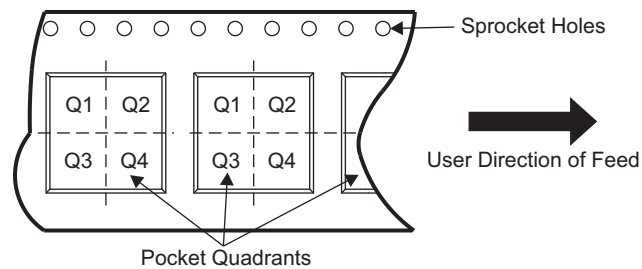
SNVSB11B – JUNE 2018 – REVISED MAY 2019

www.ti.com

## 12.1 Tape and Reel Information

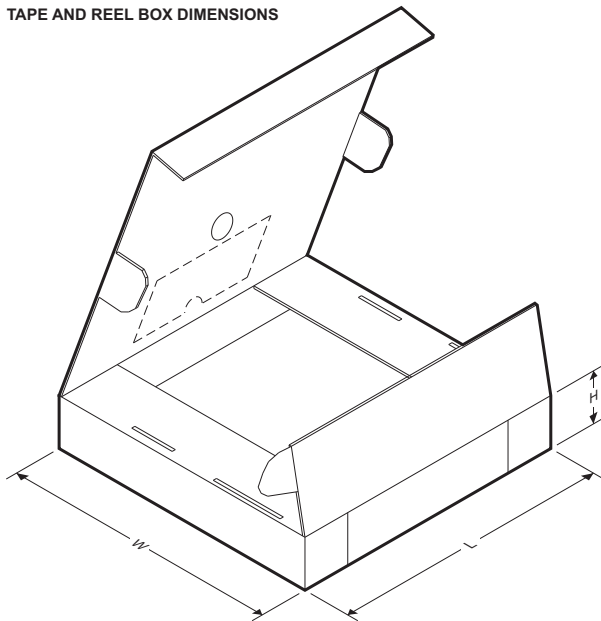


### QUADRANT ASSIGNMENTS FOR PIN 1 ORIENTATION IN TAPE



Device	Package Type	Package Drawing	Pins	SPQ	Reel Diameter (mm)	Reel Width W1 (mm)	A0 (mm)	B0 (mm)	K0 (mm)	P1 (mm)	W (mm)	Pin1 Quadrant
LMZM33606RLXR	B2QFN	RLX	41	500	330.0	32.4	10.45	16.45	4.4	16.0	32.0	Q1

### TAPE AND REEL BOX DIMENSIONS



Device	Package Type	Package Drawing	Pins	SPQ	Length (mm)	Width (mm)	Height (mm)
LMZM33606RLXR	B2QFN	RLX	41	500	383.0	353.0	58.0

**PACKAGING INFORMATION**

Orderable Device	Status (1)	Package Type	Package Drawing	Pins	Package Qty	Eco Plan (2)	Lead finish/ Ball material (6)	MSL Peak Temp (3)	Op Temp (°C)	Device Marking (4/5)	Samples
LMZM33606RLXR	ACTIVE	B3QFN	RLX	41	500	RoHS Exempt & Green	NIPDAU	Level-3-240C-168 HR	-40 to 105	LMZM33606	Samples

(1) The marketing status values are defined as follows:

**ACTIVE:** Product device recommended for new designs.

**LIFEBUY:** TI has announced that the device will be discontinued, and a lifetime-buy period is in effect.

**NRND:** Not recommended for new designs. Device is in production to support existing customers, but TI does not recommend using this part in a new design.

**PREVIEW:** Device has been announced but is not in production. Samples may or may not be available.

**OBsolete:** TI has discontinued the production of the device.

(2) **RoHS:** TI defines "RoHS" to mean semiconductor products that are compliant with the current EU RoHS requirements for all 10 RoHS substances, including the requirement that RoHS substance do not exceed 0.1% by weight in homogeneous materials. Where designed to be soldered at high temperatures, "RoHS" products are suitable for use in specified lead-free processes. TI may reference these types of products as "Pb-Free".

**RoHS Exempt:** TI defines "RoHS Exempt" to mean products that contain lead but are compliant with EU RoHS pursuant to a specific EU RoHS exemption.

**Green:** TI defines "Green" to mean the content of Chlorine (Cl) and Bromine (Br) based flame retardants meet JS709B low halogen requirements of <=1000ppm threshold. Antimony trioxide based flame retardants must also meet the <=1000ppm threshold requirement.

(3) MSL, Peak Temp. - The Moisture Sensitivity Level rating according to the JEDEC industry standard classifications, and peak solder temperature.

(4) There may be additional marking, which relates to the logo, the lot trace code information, or the environmental category on the device.

(5) Multiple Device Markings will be inside parentheses. Only one Device Marking contained in parentheses and separated by a "~" will appear on a device. If a line is indented then it is a continuation of the previous line and the two combined represent the entire Device Marking for that device.

(6) Lead finish/Ball material - Orderable Devices may have multiple material finish options. Finish options are separated by a vertical ruled line. Lead finish/Ball material values may wrap to two lines if the finish value exceeds the maximum column width.

**Important Information and Disclaimer:**The information provided on this page represents TI's knowledge and belief as of the date that it is provided. TI bases its knowledge and belief on information provided by third parties, and makes no representation or warranty as to the accuracy of such information. Efforts are underway to better integrate information from third parties. TI has taken and continues to take reasonable steps to provide representative and accurate information but may not have conducted destructive testing or chemical analysis on incoming materials and chemicals. TI and TI suppliers consider certain information to be proprietary, and thus CAS numbers and other limited information may not be available for release.

In no event shall TI's liability arising out of such information exceed the total purchase price of the TI part(s) at issue in this document sold by TI to Customer on an annual basis.

## IMPORTANT NOTICE AND DISCLAIMER

TI PROVIDES TECHNICAL AND RELIABILITY DATA (INCLUDING DATASHEETS), DESIGN RESOURCES (INCLUDING REFERENCE DESIGNS), APPLICATION OR OTHER DESIGN ADVICE, WEB TOOLS, SAFETY INFORMATION, AND OTHER RESOURCES "AS IS" AND WITH ALL FAULTS, AND DISCLAIMS ALL WARRANTIES, EXPRESS AND IMPLIED, INCLUDING WITHOUT LIMITATION ANY IMPLIED WARRANTIES OF MERCHANTABILITY, FITNESS FOR A PARTICULAR PURPOSE OR NON-INFRINGEMENT OF THIRD PARTY INTELLECTUAL PROPERTY RIGHTS.



These resources are intended for skilled developers designing with TI products. You are solely responsible for (1) selecting the appropriate TI products for your application, (2) designing, validating and testing your application, and (3) ensuring your application meets applicable standards, and any other safety, security, or other requirements. These resources are subject to change without notice. TI grants you permission to use these resources only for development of an application that uses the TI products described in the resource. Other reproduction and display of these resources is prohibited. No license is granted to any other TI intellectual property right or to any third party intellectual property right. TI disclaims responsibility for, and you will fully indemnify TI and its representatives against, any claims, damages, costs, losses, and liabilities arising out of your use of these resources.

TI's products are provided subject to TI's Terms of Sale (<https://www.ti.com/legal/termsofsale.html>) or other applicable terms available either on [ti.com](https://www.ti.com) or provided in conjunction with such TI products. TI's provision of these resources does not expand or otherwise alter TI's applicable warranties or warranty disclaimers for TI products.

Mailing Address: Texas Instruments, Post Office Box 655303, Dallas, Texas 75265  
Copyright © 2021, Texas Instruments Incorporated

## Looking for pricing, stock, or lifecycle information?

Click below to explore more details on WIN SOURCE:

-  [View HDMI2C1-5DIJ on WIN SOURCE](#)
-  [STMicroelectronics Information](#)

## Optimize Your Supply Chain with WIN SOURCE Solutions

-  Global Sourcing Solution
-  Obsolete Management
-  Cost Control Management
-  Shortage Management
-  Alternative Solution
-  Excess Inventory Management