

DATA SHEET

For a complete data sheet, please also download:

- The IC04 LOCMOS HE4000B Logic Family Specifications HEF, HEC
- The IC04 LOCMOS HE4000B Logic Package Outlines/Information HEF, HEC

HEF4000B

gates

Dual 3-input NOR gate and inverter

Product specification
File under Integrated Circuits, IC04

January 1995

Dual 3-input NOR gate and inverter

HEF4000B gates

DESCRIPTION

The HEF4000B provides the positive dual 3-input NOR function. A single stage inverting function with standard output performance is also accomplished. The outputs are fully buffered for highest noise immunity and pattern insensitivity of output impedance.

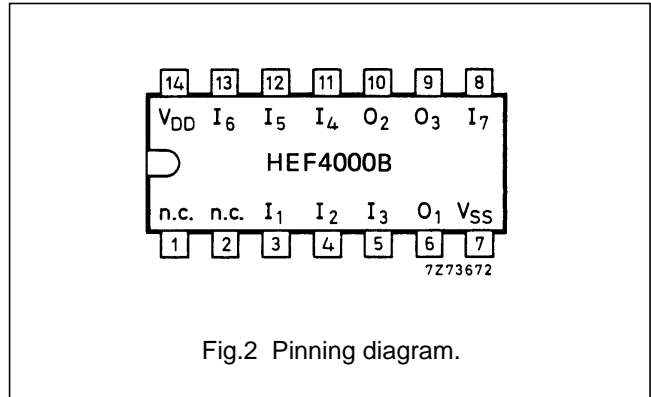
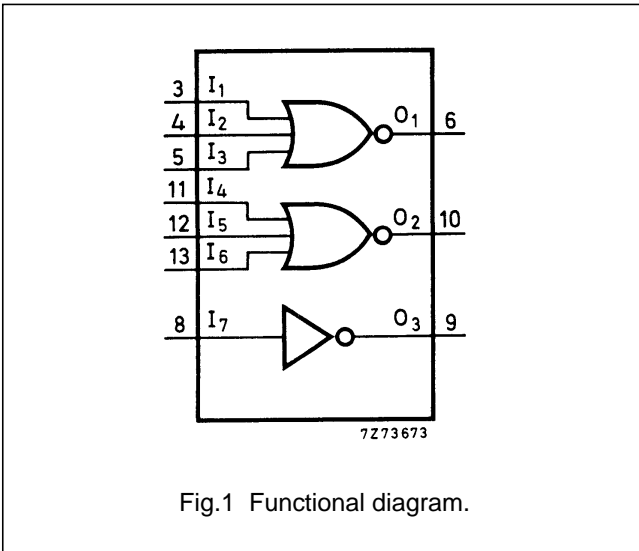

- HEF4000BP(N): 14-lead DIL; plastic (SOT27-1)
- HEF4000BD(F): 14-lead DIL; ceramic (cerdip) (SOT73)
- HEF4000BT(D): 14-lead SO; plastic (SOT108-1)
- (): Package Designator North America

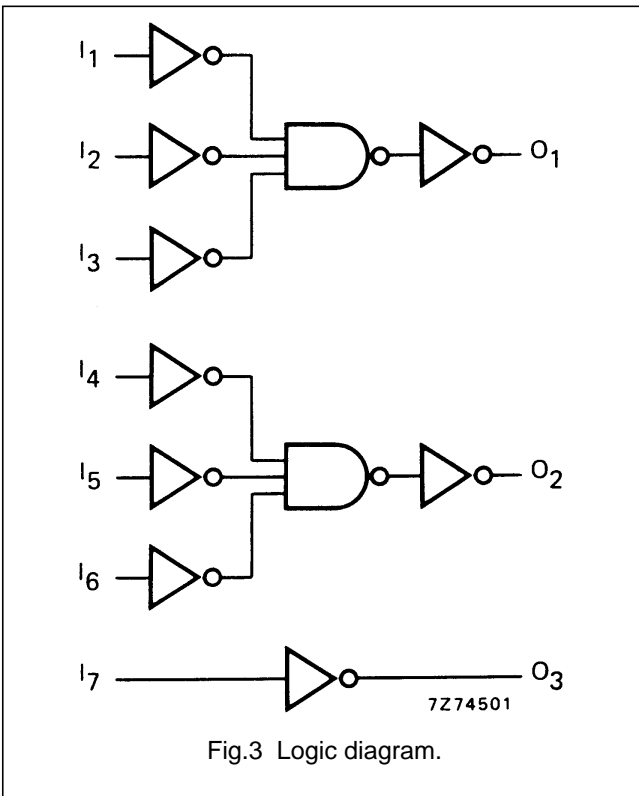

FAMILY DATA, I_{DD} LIMITS category GATES

See Family Specifications

Dual 3-input NOR gate and inverter

HEF4000B
gates**DC CHARACTERISTICS**

For the single inverter stage (I_7/O_3):

see Family Specifications for input voltages HIGH and LOW (unbuffered stages only).

AC CHARACTERISTICS

$V_{SS} = 0$ V; $T_{amb} = 25$ °C; $C_L = 50$ pF; input transition times ≤ 20 ns

	V_{DD} V	SYMBOL	TYP.	MAX.		TYPICAL EXTRAPOLATION FORMULA
Propagation delays I_1 to $I_6 \rightarrow O_1, O_2$	5	$t_{PHL}; t_{PLH}$	70	140	ns	$43 \text{ ns} + (0,55 \text{ ns/pF}) C_L$
	10		35	70	ns	$24 \text{ ns} + (0,23 \text{ ns/pF}) C_L$
	15		30	55	ns	$22 \text{ ns} + (0,16 \text{ ns/pF}) C_L$
$I_7 \rightarrow O_3$ (unbuffered output)	5	$t_{PHL}; t_{PLH}$	45	90	ns	$18 \text{ ns} + (0,55 \text{ ns/pF}) C_L$
	10		25	50	ns	$14 \text{ ns} + (0,23 \text{ ns/pF}) C_L$
	15		20	40	ns	$12 \text{ ns} + (0,16 \text{ ns/pF}) C_L$
Output transition times HIGH to LOW	5	t_{THL}	60	120	ns	$10 \text{ ns} + (1,0 \text{ ns/pF}) C_L$
	10		30	60	ns	$9 \text{ ns} + (0,42 \text{ ns/pF}) C_L$
	15		20	40	ns	$6 \text{ ns} + (0,28 \text{ ns/pF}) C_L$
LOW to HIGH	5	t_{TLH}	60	120	ns	$10 \text{ ns} + (1,0 \text{ ns/pF}) C_L$
	10		30	60	ns	$9 \text{ ns} + (0,42 \text{ ns/pF}) C_L$
	15		20	40	ns	$6 \text{ ns} + (0,28 \text{ ns/pF}) C_L$

	V_{DD} V	TYPICAL FORMULA FOR P (μ W)	
Dynamic power dissipation per package (P)	5	$1\,000 f_i + \sum (f_o C_L) \times V_{DD}^2$	where f_i = input freq. (MHz) f_o = output freq. (MHz) C_L = load capacitance (pF) $\sum (f_o C_L)$ = sum of outputs V_{DD} = supply voltage (V)
	10	$7\,700 f_i + \sum (f_o C_L) \times V_{DD}^2$	
	15	$28\,700 f_i + \sum (f_o C_L) \times V_{DD}^2$	

Dual 3-input NOR gate and inverter

HEF4000B
gates

APPLICATION INFORMATION

The following information (Figs 4 to 7) is only for the single inverter stage (I₇/O₃).

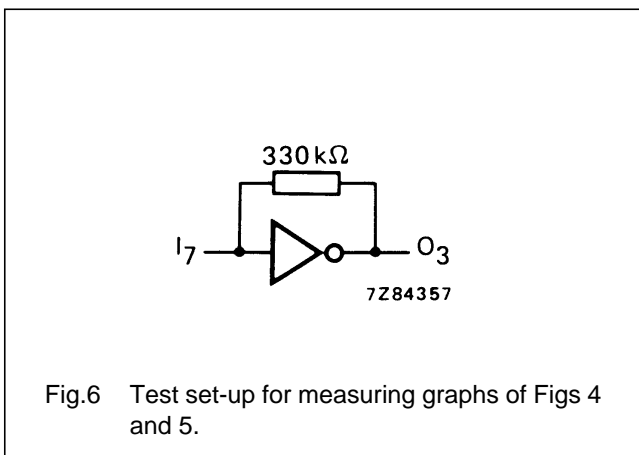
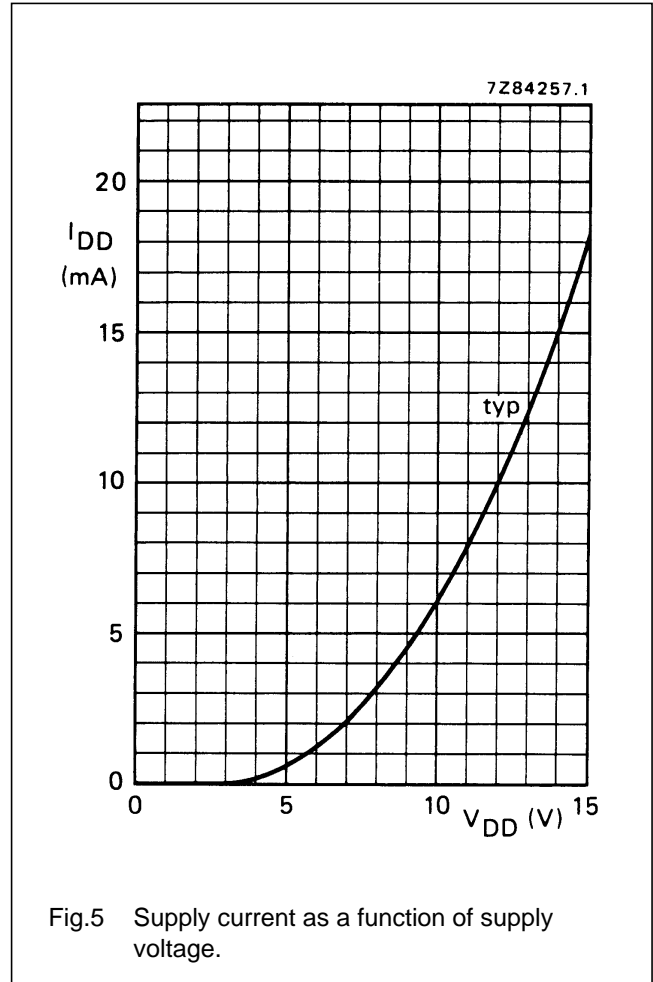
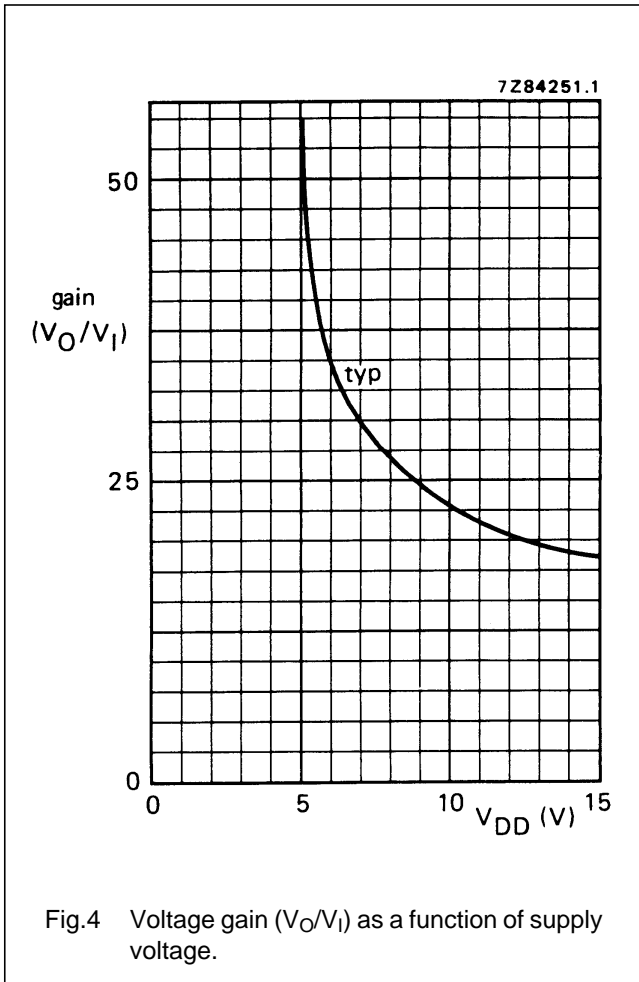

Fig.6 Test set-up for measuring graphs of Figs 4 and 5.

This is also an example of an analogue amplifier using the single inverter stage (I₇/O₃) of the HEF4000B.

Dual 3-input NOR gate and inverter

HEF4000B
gates

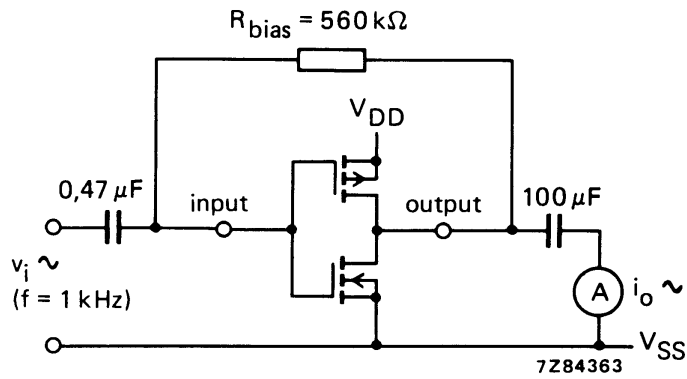
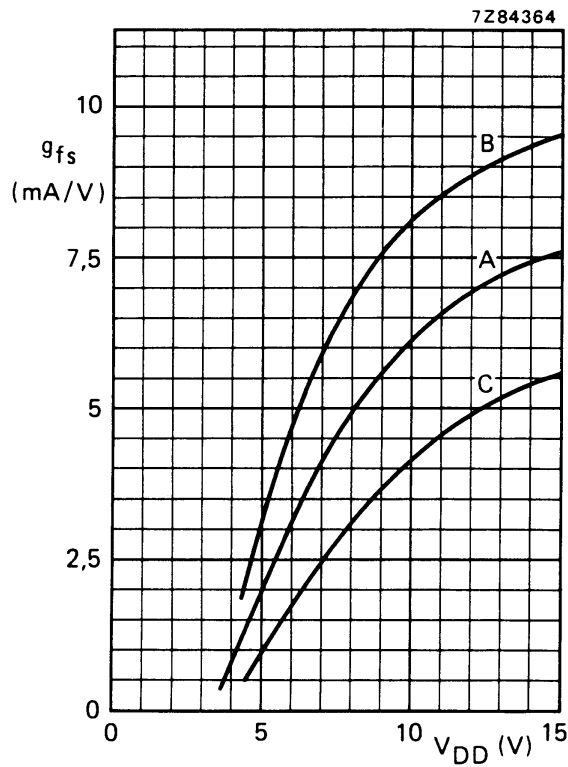

Fig.7 Test set-up for measuring forward transconductance $g_{fs} = di_o/dv_i$ at v_o is constant (see also graph Fig.8).





A: average
 B: average + 2 s,
 C: average - 2 s, in where 's' is the observed standard deviation.

Fig.8 Typical forward transconductance g_{fs} as a function of the supply voltage at $T_{amb} = 25\text{ }^\circ\text{C}$.

Looking for pricing, stock, or lifecycle information?

Click below to explore more details on WIN SOURCE:

-  [View HEF4000BT,653 on WIN SOURCE](#)
-  [NXP / Nexperia Information](#)

Optimize Your Supply Chain with WIN SOURCE Solutions

-  Global Sourcing Solution
-  Obsolete Management
-  Cost Control Management
-  Shortage Management
-  Alternative Solution
-  Excess Inventory Management