



# THE DATASHEET OF HH-3-S



**Fully Automatic Cable Tie Installation Systems**

A complete single-source solution for high volume harnessing, assembly, fastening, and packaging applications. With cycle times of less than one second, the systems are up to six times faster than conventional manual cable tie installations.



**Bundling Systems**



**Bundling and Mounting System**



**PAT/Robot Integration Kit**

**Abrasion Protection Products**

Panduit Abrasion protection products provide an economical and easy way to insulate, protect, bundle, and color-code components and cable. A wide variety of sizes and materials are available to meet a broad range of indoor and outdoor applications.



**Pan-Wrap™ Split Harness Wrap**



**Corrugated Loom Tubing**



**Braided Expandable Sleeving**



**Spiral Wrap**

**Terminals, Disconnects, Ferrules and Splices**

Connectors are available loose piece for manual installation and continuously molded for high volume automated installation. Panduit's manual and automated installation tooling improve productivity and reliability for industrial settings.



**Wide Variety of Terminals, Disconnects, and Splices**

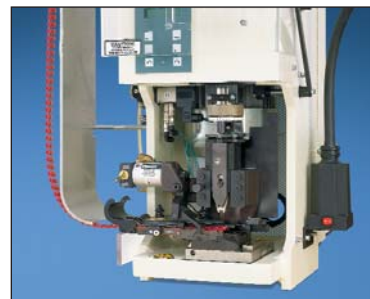

**4-Ton Press and Universal Applicator**

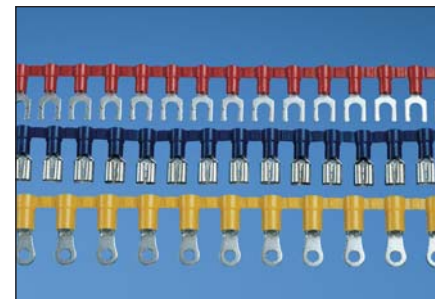

**Reel Smart™ Continuously Molded Connectors**

Dimensions are in inches (Dimensions in parentheses are metric)

**WORLDWIDE SUBSIDIARIES AND SALES OFFICES**

PANDUIT CANADA Markham, Ontario cs-cdn@panduit.com Phone: 800.777.3300	PANDUIT EUROPE LTD. London, UK cs-emea@panduit.com Phone: 44.20.8601.7200	PANDUIT SINGAPORE PTE. LTD. Republic of Singapore cs-ap@panduit.com Phone: 65.6305.7575	PANDUIT JAPAN Tokyo, Japan cs-japan@panduit.com Phone: 81.3.6863.6000	PANDUIT LATIN AMERICA Jalisco, Mexico cs-la@panduit.com Phone: 52.33.3777.6000	PANDUIT AUSTRALIA PTY. LTD. Victoria, Australia cs-aus@panduit.com Phone: 61.3.9794.9020
---	--	--	--	---	---

For a copy of Panduit product warranties, log on to [www.panduit.com/warranty](http://www.panduit.com/warranty)

**For more information**

**Visit us at [www.panduit.com](http://www.panduit.com)**

Contact Customer Service by email: [cs@panduit.com](mailto:cs@panduit.com)  
or by phone: 800-777-3300 and reference WACB20



© 2010 Panduit Corp.  
ALL RIGHTS RESERVED.  
Printed in the U.S.A.  
Product Bulletin Number SA-WACB20  
Replaces SA101N556-WA  
8/2010



**Harness Board Accessories**

Panduit harness board accessories allow an installer to quickly configure a specific arrangement of wires, to aid in required wire bundling and termination. Panduit's comprehensive line of harness board accessories can significantly reduce the labor input required for field installation of wires and cables and simplify harness board operations. These products hold wire bundles at a uniform height from a harness board to ease manual or automatic cable tie installation. These accessories help maintain end product consistency, reduce costly rework and maximize workplace safety.

**Key Features**

**Benefits**

<b>Large selection of board-mounted accessories</b>	Comprehensive and versatile offering ensures there is a product to fit virtually every harness board application
<b>A wide range of sizes</b>	Panduit harness board accessories can be used to manage wire configurations up to 2 inches bundle diameter for maximum flexibility
<b>Uniform standoff height</b>	Accessories space the wire bundle at a uniform distance and height from the harness board to allow simple cable tie application using manual or automatic tooling to speed installation
<b>Mounts designed to work with harness board accessories</b>	Panduit mounts can be integrated into the wiring harness at the harness board to simplify deploying the harness onto the finished assembly to speed installation
<b>Snap-in, snap-out functionality</b>	Harness board accessories hold the wires in a tight bundle, yet allow completed harness to be easily removed by lifting upward on the harness
<b>Spring wire breakout and wire end holders</b>	Individual wires are held in the bundle to maintain harness structure while allowing consistent termination of wires

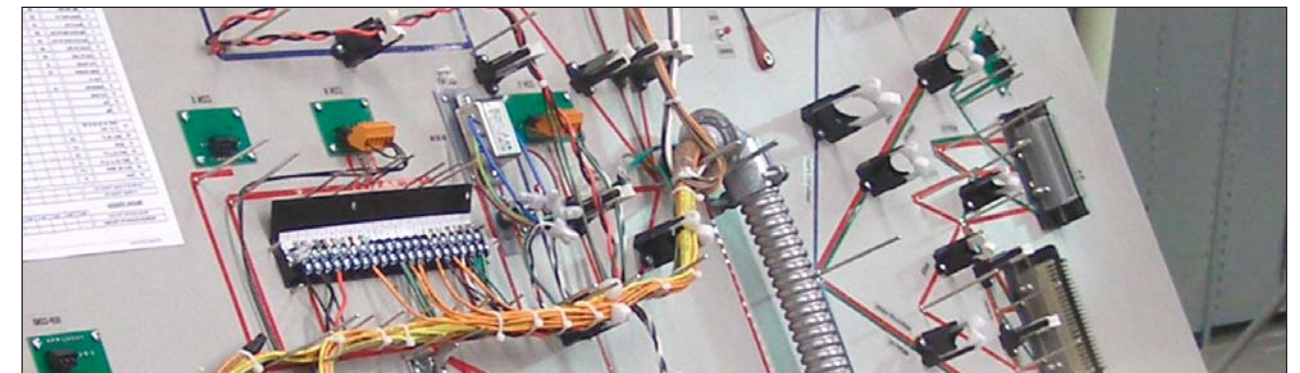

## Elastic Retainers

- Cable bundles are formed as individual wires are inserted
- Completed bundles can be easily removed

- The elastic band is replaceable

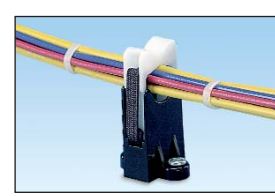

RER.50 – 1.25

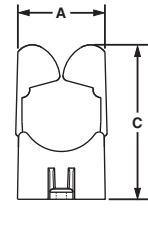

RER2.0

### Replacement Elastic

Part Number	Pkg. Qty.
RER.5E-X	10
RER.75E-X	10
RER1.25E-X	10
RER2.0E-X	10

For economy, the elastic band can be replaced in the RER Elastic Retainers without removing the RER base.

Part Number	Max. Bundle Diameter		Length A		Width B		Height C		Material	Color	Mounting Method	Std. Pkg. Qty.	Std. Ctn. Qty.
	In.	mm	In.	mm	In.	mm	In.	mm					
RER.5-S6-X	0.50	12.7	1.18	30.0	0.84	21.3	1.89	48.0	Nylon 6.6	Black Base, White Arm	Two #6 (M3) Screws	10	50
RER.75-S6-X	0.75	19.0	1.18	30.0	1.12	28.4	2.21	56.1				10	50
RER1.25-S6-X	1.25	31.8	1.18	30.0	1.64	41.7	2.86	72.6				10	50
RER2.0-S6-X	2.00	50.8	1.31	33.3	2.81	71.4	3.94	100.2				10	50

## Elastic Retainers – Low Profile

- Cable bundles are formed as cable bundles are inserted

- Completed bundles can be easily removed

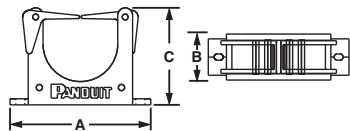

Part Number	Max. Bundle Diameter		Length A		Width B		Height C		Material	Color	Mounting Method	Std. Pkg. Qty.	Std. Ctn. Qty.
	In.	mm	In.	mm	In.	mm	In.	mm					
ER.5-E4-X	.50	12.7	1.96	49.8	.56	14.2	1.00	25.4	Nylon 6.6	Black	Two #6 (M3) Screws	10	100
ER1.25-E4-X	1.25	31.8	2.90	73.7	.95	24.1	2.00	50.8				10	100

## Bundle Retainers

- Funnel entry allows fast cable insertion
- Completed bundles can be easily removed

- Color: Black

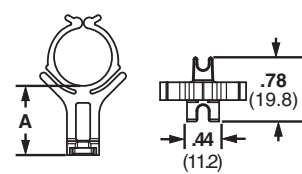

BR.5 and BR.75

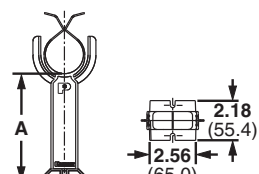

BR2

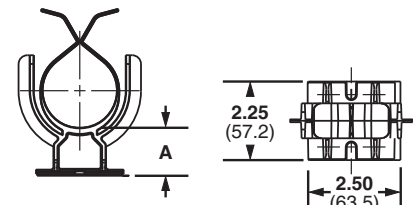

BR2-1.3

Part Number	Max. Bundle Diameter		Standoff Height A		Material	Mounting Method	Std. Pkg. Qty.	Std. Ctn. Qty.
	In.	mm	In.	mm				
BR.5-E6-C	0.50	12.7	1.07	27.2	Impact Resistant Nylon 6.6	Two #6 (M3) Screws	100	500
BR.75-E6-C	0.75	19.0	0.95	24.1			100	500
BR2-1.3-X	2.00	50.8	1.32	33.5	Glass Filled Nylon 6.6	Two 1/4" (M6) Screws	10	10
BR2-1.3-A-X	2.00	50.8	1.35	34.3		Rubber Adhesive Tape	10	10
BR2-1.5-X	2.00	50.8	1.59	40.4		10	10	
BR2-4-X	2.00	50.8	4.06	103.1		Two 1/4" (M6) Screws	10	10
BR2-6-X	2.00	50.8	6.02	152.9			10	10

## Corner Posts

- Designed to pre-form tight bundles at harness corners and breakouts

- Top arm rotates upward for easy removal of completed harness

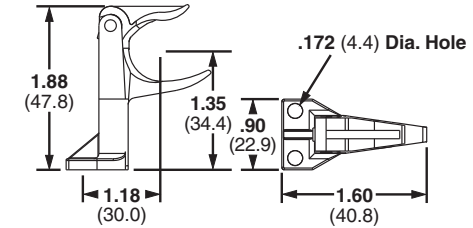

CPH

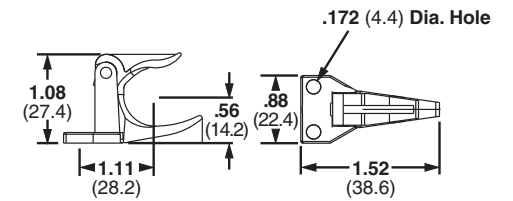

CPL

Part Number	Max. Bundle Diameter		Material	Color	Mounting Method	Std. Pkg. Qty.	Std. Ctn. Qty.
	In.	mm					
CPH.75-S8-X	.75	19.0	Nylon 6.6	Black	Two #8 (M4) Screws	10	100
CPL.75-S8-X							

## T-Junction Fixture

- Forms cable junctions

- Fixture moves down for easy harness removal

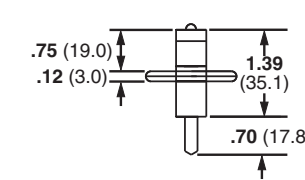

Part Number	Max. Bundle Diameter		Material	Color	Mounting Method	Std. Pkg. Qty.	Std. Ctn. Qty.
	In.	mm					
TJF-X	1.34	34.0	Nylon 6.6 and Nickel Plated Steel	Black	Nail	10	100

## Harness Board Nails

- Speed routing of wires
- Uniform driving depth is insured by a collar stop

- Smooth finish on nails prevents abrasion to wire jackets

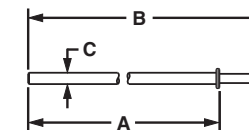

Part Number	Length A		Overall Length B		Thickness C		Material	Mounting Method	Std. Pkg. Qty.	Std. Ctn. Qty.
	In.	mm	In.	mm	In.	mm				
HBN.75-T	.75	19.1	1.40	35.56	.07	1.9	Nickel Plated Steel	Hammered into harness board	200	1000
HBN1-T	1.00	25.4	1.65	41.91	.07	1.9			200	1000
HBN1.5-T	1.50	38.1	2.16	54.86	.08	2.1			200	1000
HBN2-T	2.00	50.8	2.66	67.56	.09	2.4			200	1000
HBN2.5-T	2.50	63.5	3.16	80.26	.11	2.8			200	1000
HBN3-T	3.00	76.2	3.67	93.22	.12	3.0			200	1000
HBN4-T	4.00	101.6	4.67	118.62	.14	3.7			200	1000

## Elastic Retainers

- Cable bundles are formed as individual wires are inserted
- Completed bundles can be easily removed

- The elastic band is replaceable

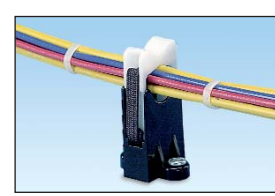

RER.50 – 1.25

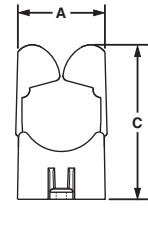

RER2.0

### Replacement Elastic

Part Number	Pkg. Qty.
RER.5E-X	10
RER.75E-X	10
RER1.25E-X	10
RER2.0E-X	10

For economy, the elastic band can be replaced in the RER Elastic Retainers without removing the RER base.

Part Number	Max. Bundle Diameter		Length A		Width B		Height C		Material	Color	Mounting Method	Std. Pkg. Qty.	Std. Ctn. Qty.
	In.	mm	In.	mm	In.	mm	In.	mm					
RER.5-S6-X	0.50	12.7	1.18	30.0	0.84	21.3	1.89	48.0	Nylon 6.6	Black Base, White Arm	Two #6 (M3) Screws	10	50
RER.75-S6-X	0.75	19.0	1.18	30.0	1.12	28.4	2.21	56.1				10	50
RER1.25-S6-X	1.25	31.8	1.18	30.0	1.64	41.7	2.86	72.6				10	50
RER2.0-S6-X	2.00	50.8	1.31	33.3	2.81	71.4	3.94	100.2				10	50

## Elastic Retainers – Low Profile

- Cable bundles are formed as cable bundles are inserted

- Completed bundles can be easily removed

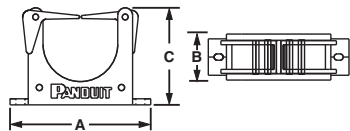

Part Number	Max. Bundle Diameter		Length A		Width B		Height C		Material	Color	Mounting Method	Std. Pkg. Qty.	Std. Ctn. Qty.
	In.	mm	In.	mm	In.	mm	In.	mm					
ER.5-E4-X	.50	12.7	1.96	49.8	.56	14.2	1.00	25.4	Nylon 6.6	Black	Two #6 (M3) Screws	10	100
ER1.25-E4-X	1.25	31.8	2.90	73.7	.95	24.1	2.00	50.8				10	100

## Bundle Retainers

- Funnel entry allows fast cable insertion
- Completed bundles can be easily removed

- Color: Black

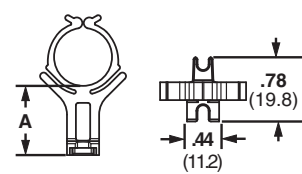

BR.5 and BR.75

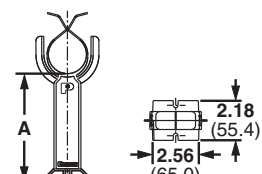

BR2

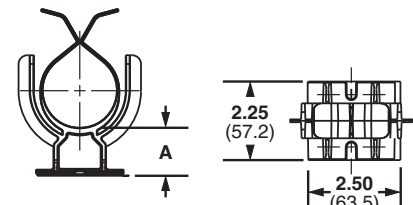

BR2-1.3

Part Number	Max. Bundle Diameter		Standoff Height A		Material	Mounting Method	Std. Pkg. Qty.	Std. Ctn. Qty.
	In.	mm	In.	mm				
BR.5-E6-C	0.50	12.7	1.07	27.2	Impact Resistant Nylon 6.6	Two #6 (M3) Screws	100	500
BR.75-E6-C	0.75	19.0	0.95	24.1			100	500
BR2-1.3-X	2.00	50.8	1.32	33.5	Glass Filled Nylon 6.6	Two 1/4" (M6) Screws	10	10
BR2-1.3-A-X	2.00	50.8	1.35	34.3		Rubber Adhesive Tape	10	10
BR2-1.5-X	2.00	50.8	1.59	40.4		10	10	
BR2-4-X	2.00	50.8	4.06	103.1		Two 1/4" (M6) Screws	10	10
BR2-6-X	2.00	50.8	6.02	152.9			10	10

## Corner Posts

- Designed to pre-form tight bundles at harness corners and breakouts

- Top arm rotates upward for easy removal of completed harness

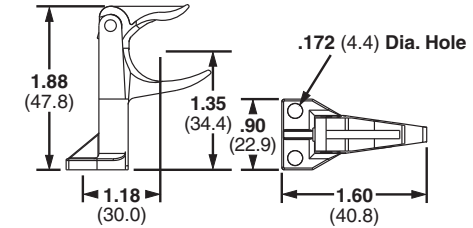

CPH

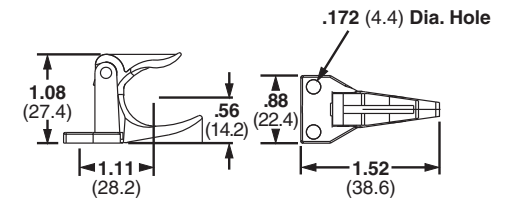

CPL

Part Number	Max. Bundle Diameter		Material	Color	Mounting Method	Std. Pkg. Qty.	Std. Ctn. Qty.
	In.	mm					
CPH.75-S8-X	.75	19.0	Nylon 6.6	Black	Two #8 (M4) Screws	10	100
CPL.75-S8-X							

## T-Junction Fixture

- Forms cable junctions

- Fixture moves down for easy harness removal

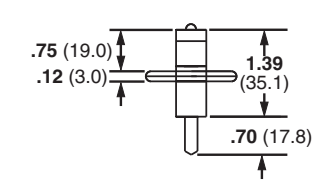

Part Number	Max. Bundle Diameter		Material	Color	Mounting Method	Std. Pkg. Qty.	Std. Ctn. Qty.
	In.	mm					
TJF-X	1.34	34.0	Nylon 6.6 and Nickel Plated Steel	Black	Nail	10	100

## Harness Board Nails

- Speed routing of wires
- Uniform driving depth is insured by a collar stop

- Smooth finish on nails prevents abrasion to wire jackets

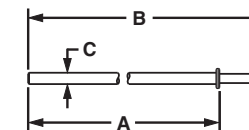

Part Number	Length A		Overall Length B		Thickness C		Material	Mounting Method	Std. Pkg. Qty.	Std. Ctn. Qty.
	In.	mm	In.	mm	In.	mm				
HBN.75-T	.75	19.1	1.40	35.56	.07	1.9	Nickel Plated Steel	Hammered into harness board	200	1000
HBN1-T	1.00	25.4	1.65	41.91	.07	1.9			200	1000
HBN1.5-T	1.50	38.1	2.16	54.86	.08	2.1			200	1000
HBN2-T	2.00	50.8	2.66	67.56	.09	2.4			200	1000
HBN2.5-T	2.50	63.5	3.16	80.26	.11	2.8			200	1000
HBN3-T	3.00	76.2	3.67	93.22	.12	3.0			200	1000
HBN4-T	4.00	101.6	4.67	118.62	.14	3.7			200	1000

Wire End Holder

- Secures wire ends while harness is being fabricated
- Used with #28 thru #16 AWG wires

- For indoor use only

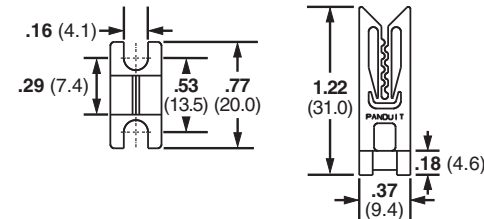

Part Number	Material	Color	Mounting Method	Std. Pkg. Qty.	Std. Ctn. Qty.
WEH-E8-C	Acetal	Black	Two #8 (M4) Screws	100	1000

Spring Wire Breakout System

- Harness board spring and spring holder holds wire ends secure while harness is being fabricated
- Wires simply pull out from spring when harness is removed

- Each SHH Spring Holder is supplied with one rigid wire piece to hold the spring laterally and two #8 (M4), 2 inch (50.8mm) hex head wood screws; purchase spring separately

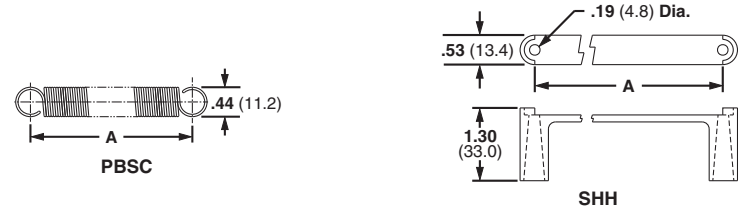
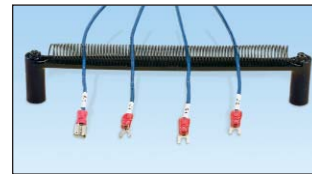

Part Number	Hole Spacing A		Material	Color	Mounting Method	Std. Pkg. Qty.	Std. Ctn. Qty.
	In.	mm					
PBSC1-X	1.00	25.4	Steel	—	SHH1 Spring Holder	10	100
PBSC3-X	3.00	76.2		—	Two #8 (M4) Screws	10	100
PBSC6-X	6.00	152.4		—	SHH3 Spring Holder	10	100
PBSC12-X	12.00	304.8		—	Two #8 (M4) Screws	10	100
SHH1-S8-X	1.85	47.0	Nylon 6.6	Natural	Two #8 (M4) Screws	10	100
SHH3-S8-X	6.80	172.7			Two #8 (M4) Screws	10	100

Fanning Strip System

- Holds wires in a specific orientation
- No sharp edges to damage wire insulation

- Will accept wires up to 18 AWG
- Fanning strip can remain as part of completed harness

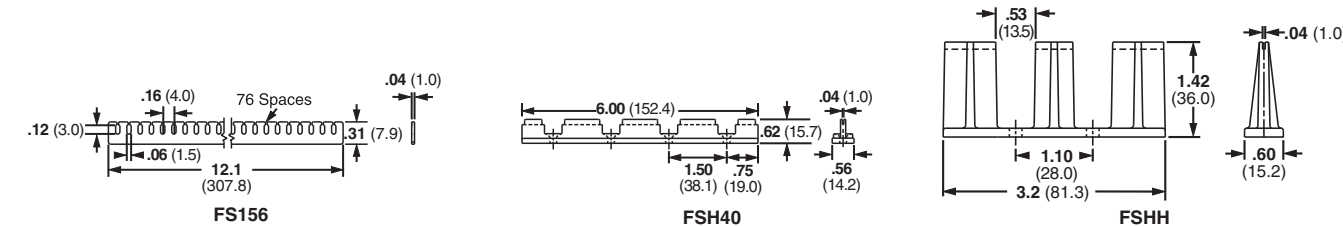

Part Number	Material	Color	Mounting Method	Std. Pkg. Qty.	Std. Ctn. Qty.
FS156-C	Nylon 6.6	Natural	FSH Holder	100	1000
FSH40-X	ABS	Black	Four #8 (M4) Screws	10	100
FSHH-X			Two #8 (M4) Screws	10	100

Harness Board Standoff Posts and Adapter

- Used to hold a push mount accessory or cable tie at a specific location on a harness board

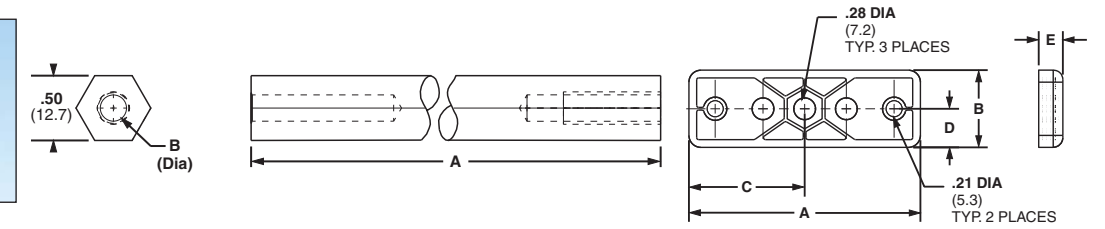

Part Number	Height A		Hole Diameter B		Length C		Width D		For Use With	Material	Mounting Method	Std. Pkg. Qty.	Std. Ctn. Qty.
	In.	mm	In.	mm	In.	mm	In.	mm					
HB2SP19-X	2.00	50.8	.20	5.2	2.00	50.8	.50	12.7	PLWP, PRWP, WS, VWS, HWS, TPM	Aluminum	M6 Screw	10	100
HB2SP25-X	2.00	50.8	.30	7.5	4.00	101.6	.50	12.7	PLWP, PRWP, PLP, THMS, HCMP, PMCC	Aluminum	M6 Screw	10	100
HBUA-X	.31	7.9	.28	7.1	3.00	76.2	1.00	25.4	HB2SP19-X, HB2SP25-X	Nylon 6.6	#10 (M5) Screw	10	100

Tie Harness Mounts – Nylon and Heat Stabilized Nylon 6.6

- Designed to be attached to the wire harness during assembly
- Cable ties can be installed by hand or with Panduit automatic cable tie tools
- Used with harness board standoff posts

- Available with or without corrugated tubing location tab
- Natural nylon material for indoor use
- Heat stabilized nylon material (30) for high temperature applications – indoor use

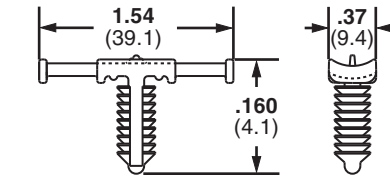

Part Number	Used with Cable Ties*	Maximum Panel Thickness		Panel Hole Diameter		Material	Color	Mounting Method	Std. Pkg. Qty.	Std. Ctn. Qty.
		In.	mm	In.	mm					

FOR CORRUGATED TUBING – A location tab on the mount shelf aligns with the corrugated tubing grooves to ensure proper mount location during assembly

THMSP20-C	M, I, S	.160	4.1	.244 – .283	6.2 – 7.2	Nylon 6.6	Natural	Push barb	100	1000
THMSP20-C30	M, I, S	.160	4.1	.244 – .283	6.2 – 7.2	Heat Stabilized Nylon 6.6	Black	Push barb	100	1000
THMSP25-C	M, I, S	.230	5.8	.244 – .283	6.2 – 7.2	Nylon 6.6	Natural	Push barb	100	1000
THMSP25-C30	M, I, S	.230	5.8	.244 – .283	6.2 – 7.2	Heat Stabilized Nylon 6.6	Black	Push barb	100	1000

FOR DISCRETE WIRING – No location tab

THMSP20F-C	M, I, S	.160	4.1	.244 – .283	6.2 – 7.2	Nylon 6.6	Natural	Push barb	100	1000
THMSP20F-C30	M, I, S	.160	4.1	.244 – .283	6.2 – 7.2	Heat Stabilized Nylon 6.6	Black	Push barb	100	1000
THMSP25F-C	M, I, S	.230	5.8	.244 – .283	6.2 – 7.2	Nylon 6.6	Natural	Push barb	100	1000
THMSP25F-C30	M, I, S	.230	5.8	.244 – .283	6.2 – 7.2	Heat Stabilized Nylon 6.6	Black	Push barb	100	1000

\*Cable tie cross section sizes: M = Miniature, I = Intermediate, S = Standard.

Wire End Holder

- Secures wire ends while harness is being fabricated
- Used with #28 thru #16 AWG wires

- For indoor use only

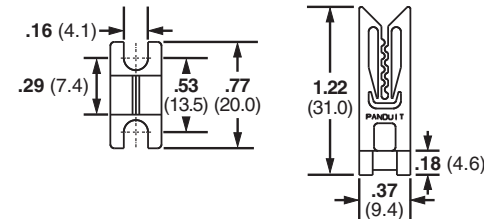

Part Number	Material	Color	Mounting Method	Std. Pkg. Qty.	Std. Ctn. Qty.
WEH-E8-C	Acetal	Black	Two #8 (M4) Screws	100	1000

Spring Wire Breakout System

- Harness board spring and spring holder holds wire ends secure while harness is being fabricated
- Wires simply pull out from spring when harness is removed

- Each SHH Spring Holder is supplied with one rigid wire piece to hold the spring laterally and two #8 (M4), 2 inch (50.8mm) hex head wood screws; purchase spring separately

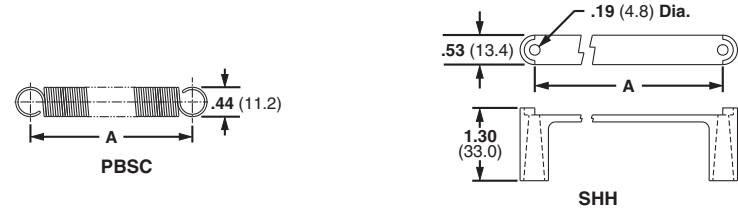
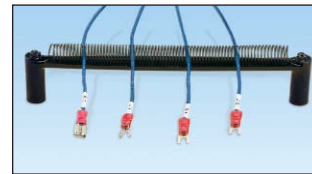

Part Number	Hole Spacing A		Material	Color	Mounting Method	Std. Pkg. Qty.	Std. Ctn. Qty.
	In.	mm					
PBSC1-X	1.00	25.4	Steel	—	SHH1 Spring Holder	10	100
PBSC3-X	3.00	76.2		—	Two #8 (M4) Screws	10	100
PBSC6-X	6.00	152.4		—	SHH3 Spring Holder	10	100
PBSC12-X	12.00	304.8		—	Two #8 (M4) Screws	10	100
SHH1-S8-X	1.85	47.0	Nylon 6.6	Natural	Two #8 (M4) Screws	10	100
SHH3-S8-X	6.80	172.7			Two #8 (M4) Screws	10	100

Fanning Strip System

- Holds wires in a specific orientation
- No sharp edges to damage wire insulation

- Will accept wires up to 18 AWG
- Fanning strip can remain as part of completed harness

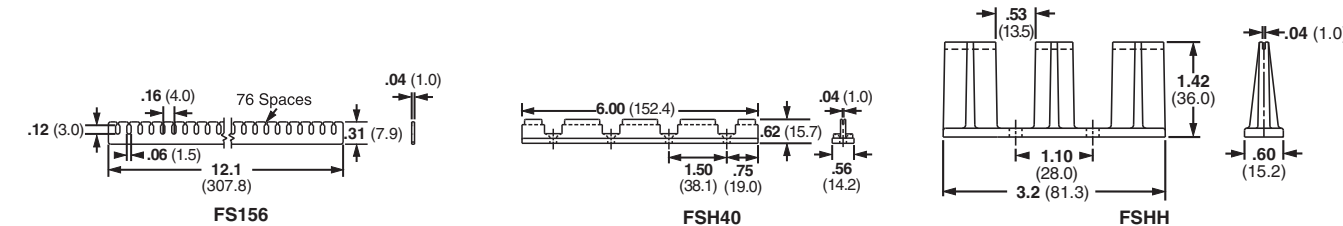

Part Number	Material	Color	Mounting Method	Std. Pkg. Qty.	Std. Ctn. Qty.
FS156-C	Nylon 6.6	Natural	FSH Holder	100	1000
FSH40-X	ABS	Black	Four #8 (M4) Screws	10	100
FSHH-X			Two #8 (M4) Screws	10	100

Harness Board Standoff Posts and Adapter

- Used to hold a push mount accessory or cable tie at a specific location on a harness board

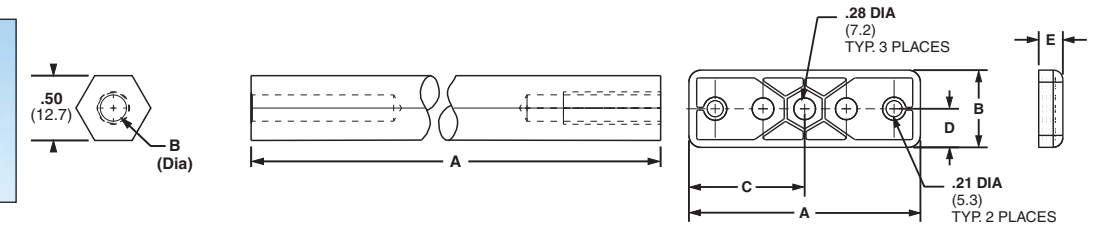

Part Number	Height A		Hole Diameter B		Length C		Width D		For Use With	Material	Mounting Method	Std. Pkg. Qty.	Std. Ctn. Qty.
	In.	mm	In.	mm	In.	m	In.	mm					
HB2SP19-X	2.00	50.8	.20	5.2	2.00	50.8	.50	12.7	PLWP, PRWP, WS, VWS, HWS, TPM	Aluminum	M6 Screw	10	100
HB2SP25-X	2.00	50.8	.30	7.5	4.00	101.6	.50	12.7	PLWP, PRWP, PLP, THMS, HCMP, PMCC	Aluminum	M6 Screw	10	100
HBUA-X	.31	7.9	.28	7.1	3.00	76.2	1.00	25.4	HB2SP19-X, HB2SP25-X	Nylon 6.6	#10 (M5) Screw	10	100

Tie Harness Mounts – Nylon and Heat Stabilized Nylon 6.6

- Designed to be attached to the wire harness during assembly
- Cable ties can be installed by hand or with Panduit automatic cable tie tools
- Used with harness board standoff posts

- Available with or without corrugated tubing location tab
- Natural nylon material for indoor use
- Heat stabilized nylon material (30) for high temperature applications – indoor use

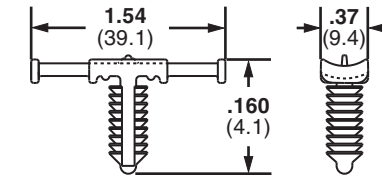

Part Number	Used with Cable Ties*	Maximum Panel Thickness		Panel Hole Diameter		Material	Color	Mounting Method	Std. Pkg. Qty.	Std. Ctn. Qty.
		In.	mm	In.	mm					

FOR CORRUGATED TUBING – A location tab on the mount shelf aligns with the corrugated tubing grooves to ensure proper mount location during assembly

THMSP20-C	M, I, S	.160	4.1	.244 – .283	6.2 – 7.2	Nylon 6.6	Natural	Push barb	100	1000
THMSP20-C30	M, I, S	.160	4.1	.244 – .283	6.2 – 7.2	Heat Stabilized Nylon 6.6	Black	Push barb	100	1000
THMSP25-C	M, I, S	.230	5.8	.244 – .283	6.2 – 7.2	Nylon 6.6	Natural	Push barb	100	1000
THMSP25-C30	M, I, S	.230	5.8	.244 – .283	6.2 – 7.2	Heat Stabilized Nylon 6.6	Black	Push barb	100	1000

FOR DISCRETE WIRING – No location tab

THMSP20F-C	M, I, S	.160	4.1	.244 – .283	6.2 – 7.2	Nylon 6.6	Natural	Push barb	100	1000
THMSP20F-C30	M, I, S	.160	4.1	.244 – .283	6.2 – 7.2	Heat Stabilized Nylon 6.6	Black	Push barb	100	1000
THMSP25F-C	M, I, S	.230	5.8	.244 – .283	6.2 – 7.2	Nylon 6.6	Natural	Push barb	100	1000
THMSP25F-C30	M, I, S	.230	5.8	.244 – .283	6.2 – 7.2	Heat Stabilized Nylon 6.6	Black	Push barb	100	1000

\*Cable tie cross section sizes: M = Miniature, I = Intermediate, S = Standard.

Automatic Cable Tie Mounts



- Multiple sizes work with industry standard panel thickness and hole diameters for greater application flexibility
- Low profile design keeps bundle close to mounting surface saving space where tight assemblies are required, and providing greater protection for bundles in high vibration applications
- Load rating of mounts supports compatible BT1.5M-XMR and PLT1.5M-XMR cable ties

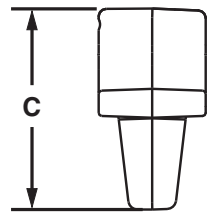
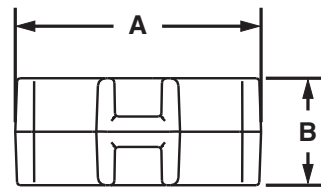

Part Number	Used with Cable Ties	A Length		B Width		C Height		Maximum Panel Thickness		Panel Hole Diameter Range		Material	Color	Std. Pkg. Qty.	Std. Ctn. Qty.
		In.	mm	In.	mm	In.	mm	In.	mm	In.	mm				
ATM-W187-M	BT1.5M-XMR, PLT1.5M-XMR	.80	20.5	.35	9.0	.12	3.0	.17 – .20	4.3 – 4.9	Nylon 6.6	Natural	1000	5000		
ATM-W187-M20											Black	1000	5000		
ATM-W187-M30											Heat Stabilized Nylon 6.6	1000	5000		
ATM-W250-M											Natural	1000	5000		
ATM-W250-M20											Black	1000	5000		
ATM-W250-M30											Heat Stabilized Nylon 6.6	1000	5000		

Order number of pieces required, in multiples of Standard Package Quantity.

Harness Board Fixtures

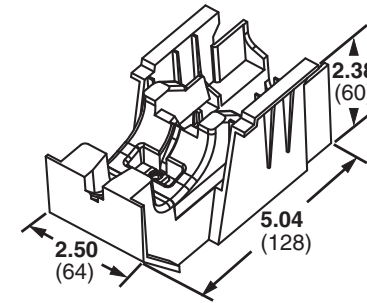

ATMB (Base)

- Automatic alignment orients the tool head with the mount for reliable feeding of the cable tie through the mount to speed installation
- Multiple fixture configurations allow mounting in horizontal, vertical, or 45° orientation to reduce installation time and improve ergonomics
- Color designation ensures inserts and mounts are correctly matched
- Integrated switch\* capability enables placement of a switch to detect the mount's presence providing an input to a quality control system, eliminating the need for additional inspection
- Activation device on harness board fixture prevents tool from operating unless it is properly engaged in the fixture for operator safety



Part Number	Description	Mounting	Color	Material	Std. Pkg. Qty.*	Std. Ctn. Qty.
ATMB	Base	Screw base to harness board with 1/4" screws	Black	Acetal	10	10
ATMI-W187-X	Insert for ATM-W187 mount	Snaps into ATMB	Yellow	Acetal	10	50
ATMI-W250-X	Insert for ATM-W250 mount	Snaps into ATMB	Red	Acetal	10	50
ATMI-XMR	Used for cable tie installations where mounts are NOT required	Snaps into ATMB	Black	Acetal	10	50
ATMC	Clamp used to secure the ATMB (base) in a vertical or 45° position	Screw clamp to harness board with 1/4" screws	Black	Steel	10	10

Order number of pieces required, in multiples of Standard Package Quantity.

\*The Omron Electronics D2SW-3L1HS switch is compatible with the ATM system. Similar switches from other manufacturers may also be suitable.

Omron is a registered trademark of Omron Corporation.

Automatic Cable Tie Mounts



- Multiple sizes work with industry standard panel thickness and hole diameters for greater application flexibility
- Low profile design keeps bundle close to mounting surface saving space where tight assemblies are required, and providing greater protection for bundles in high vibration applications
- Load rating of mounts supports compatible BT1.5M-XMR and PLT1.5M-XMR cable ties

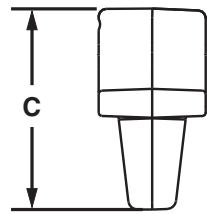
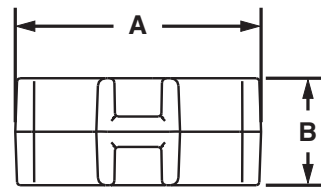

Part Number	Used with Cable Ties	A Length		B Width		C Height		Maximum Panel Thickness		Panel Hole Diameter Range		Material	Color	Std. Pkg. Qty.	Std. Ctn. Qty.
		In.	mm	In.	mm	In.	mm	In.	mm	In.	mm				
ATM-W187-M	BT1.5M-XMR, PLT1.5M-XMR	.80	20.5	.35	9.0	.12	3.0	.17 – .20	4.3 – 4.9			Natural	1000	5000	
ATM-W187-M20												Black	1000	5000	
ATM-W187-M30												Heat Stabilized Nylon 6.6	1000	5000	
ATM-W250-M												Natural	1000	5000	
ATM-W250-M20												Black	1000	5000	
ATM-W250-M30												Heat Stabilized Nylon 6.6	1000	5000	

Order number of pieces required, in multiples of Standard Package Quantity.

Harness Board Fixtures

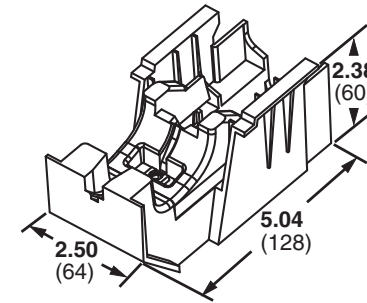

ATMB (Base)

- Automatic alignment orients the tool head with the mount for reliable feeding of the cable tie through the mount to speed installation
- Multiple fixture configurations allow mounting in horizontal, vertical, or 45° orientation to reduce installation time and improve ergonomics
- Color designation ensures inserts and mounts are correctly matched
- Integrated switch\* capability enables placement of a switch to detect the mount's presence providing an input to a quality control system, eliminating the need for additional inspection
- Activation device on harness board fixture prevents tool from operating unless it is properly engaged in the fixture for operator safety



Part Number	Description	Mounting	Color	Material	Std. Pkg. Qty.*	Std. Ctn. Qty.
ATMB	Base	Screw base to harness board with 1/4" screws	Black	Acetal	10	10
ATMI-W187-X	Insert for ATM-W187 mount	Snaps into ATMB	Yellow	Acetal	10	50
ATMI-W250-X	Insert for ATM-W250 mount	Snaps into ATMB	Red	Acetal	10	50
ATMI-XMR	Used for cable tie installations where mounts are NOT required	Snaps into ATMB	Black	Acetal	10	50
ATMC	Clamp used to secure the ATMB (base) in a vertical or 45° position	Screw clamp to harness board with 1/4" screws	Black	Steel	10	10

Order number of pieces required, in multiples of Standard Package Quantity.

\*The Omron Electronics D2SW-3L1HS switch is compatible with the ATM system. Similar switches from other manufacturers may also be suitable.

Omron is a registered trademark of Omron Corporation.

**Fully Automatic Cable Tie Installation Systems**

A complete single-source solution for high volume harnessing, assembly, fastening, and packaging applications. With cycle times of less than one second, the systems are up to six times faster than conventional manual cable tie installations.



**Bundling Systems**



**Bundling and Mounting System**



**PAT/Robot Integration Kit**

**Abrasion Protection Products**

Panduit Abrasion protection products provide an economical and easy way to insulate, protect, bundle, and color-code components and cable. A wide variety of sizes and materials are available to meet a broad range of indoor and outdoor applications.



**Pan-Wrap™ Split Harness Wrap**



**Corrugated Loom Tubing**



**Braided Expandable Sleeving**



**Spiral Wrap**

**Terminals, Disconnects, Ferrules and Splices**

Connectors are available loose piece for manual installation and continuously molded for high volume automated installation. Panduit's manual and automated installation tooling improve productivity and reliability for industrial settings.



**Wide Variety of Terminals, Disconnects, and Splices**

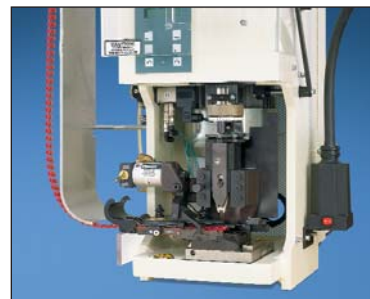

**4-Ton Press and Universal Applicator**

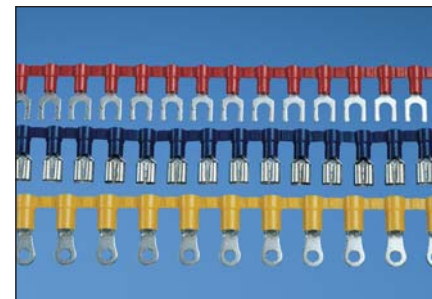

**Reel Smart™ Continuously Molded Connectors**

Dimensions are in inches (Dimensions in parentheses are metric)

**WORLDWIDE SUBSIDIARIES AND SALES OFFICES**

PANDUIT CANADA Markham, Ontario cs-cdn@panduit.com Phone: 800.777.3300	PANDUIT EUROPE LTD. London, UK cs-emea@panduit.com Phone: 44.20.8601.7200	PANDUIT SINGAPORE PTE. LTD. Republic of Singapore cs-ap@panduit.com Phone: 65.6305.7575	PANDUIT JAPAN Tokyo, Japan cs-japan@panduit.com Phone: 81.3.6863.6000	PANDUIT LATIN AMERICA Jalisco, Mexico cs-la@panduit.com Phone: 52.33.3777.6000	PANDUIT AUSTRALIA PTY. LTD. Victoria, Australia cs-aus@panduit.com Phone: 61.3.9794.9020
---	--	--	--	---	---

For a copy of Panduit product warranties, log on to [www.panduit.com/warranty](http://www.panduit.com/warranty)

**For more information**

**Visit us at [www.panduit.com](http://www.panduit.com)**

Contact Customer Service by email: [cs@panduit.com](mailto:cs@panduit.com)  
or by phone: 800-777-3300 and reference WACB20



© 2010 Panduit Corp.  
ALL RIGHTS RESERVED.  
Printed in the U.S.A.  
Product Bulletin Number SA-WACB20  
Replaces SA101N556-WA  
8/2010



**Harness Board Accessories**

Panduit harness board accessories allow an installer to quickly configure a specific arrangement of wires, to aid in required wire bundling and termination. Panduit's comprehensive line of harness board accessories can significantly reduce the labor input required for field installation of wires and cables and simplify harness board operations. These products hold wire bundles at a uniform height from a harness board to ease manual or automatic cable tie installation. These accessories help maintain end product consistency, reduce costly rework and maximize workplace safety.

**Key Features**

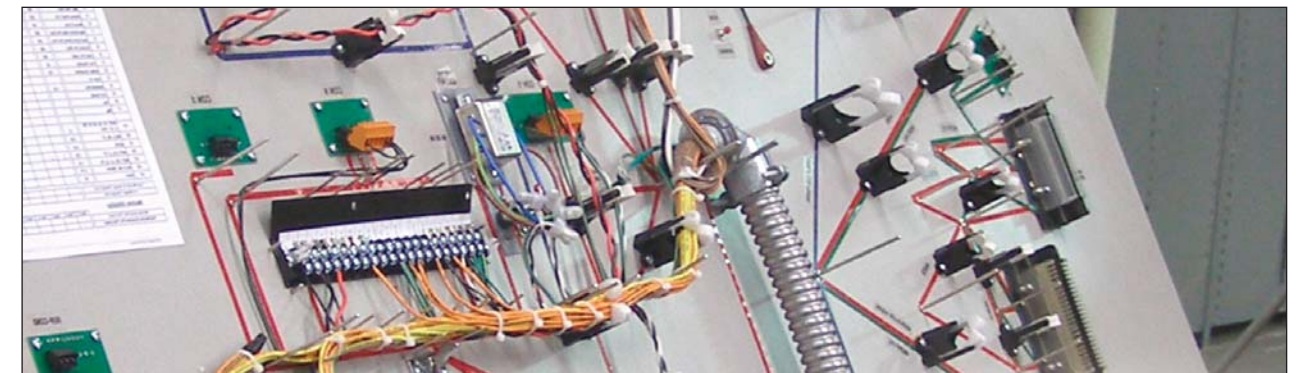

**Benefits**

<b>Large selection of board-mounted accessories</b>	Comprehensive and versatile offering ensures there is a product to fit virtually every harness board application
<b>A wide range of sizes</b>	Panduit harness board accessories can be used to manage wire configurations up to 2 inches bundle diameter for maximum flexibility
<b>Uniform standoff height</b>	Accessories space the wire bundle at a uniform distance and height from the harness board to allow simple cable tie application using manual or automatic tooling to speed installation
<b>Mounts designed to work with harness board accessories</b>	Panduit mounts can be integrated into the wiring harness at the harness board to simplify deploying the harness onto the finished assembly to speed installation
<b>Snap-in, snap-out functionality</b>	Harness board accessories hold the wires in a tight bundle, yet allow completed harness to be easily removed by lifting upward on the harness
<b>Spring wire breakout and wire end holders</b>	Individual wires are held in the bundle to maintain harness structure while allowing consistent termination of wires



## Looking for pricing, stock, or lifecycle information?

Click below to explore more details on WIN SOURCE:

-  [View HH-3-S on WIN SOURCE](#)
-  [Panduit Corp](#) Information

## Optimize Your Supply Chain with WIN SOURCE Solutions

-  Global Sourcing Solution
-  Obsolete Management
-  Cost Control Management
-  Shortage Management
-  Alternative Solution
-  Excess Inventory Management