



**THE DATASHEET OF  
HI0805R800R-00**



# Steward

Advanced Ferrite Materials, EMI Suppression, and Inductive Products

Home • Ferrite Product Lines • New Products • Technical • General • Contact • Steward Sales

## HI0805R800R-01

STEWARD PART NUMBERING SYSTEM					
28	F	0121	- 0	S	R
MATERIAL TYPE	PRODUCT CODE	PART SIZE CODE	SELECTED DIMENSION CODE	ADDITIONAL DESCRIPTION	PACKAGING CODE

Ambient Operating Temperature Range :-55°C to +125°C

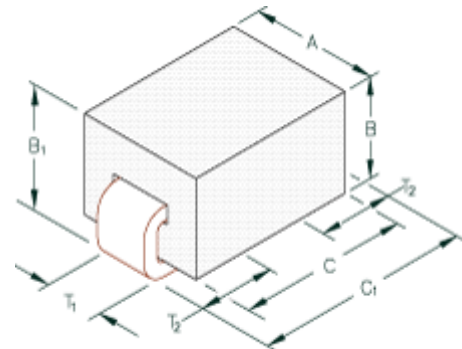

Figure #1

STEWARD PART NUMBERING SYSTEM					
DM	3312	X	101	R	(10 Pb Free) - 00
PRODUCT SERIES CODE	PART SIZE CODE	RATED CURRENT CODE	IMPEDANCE VALUE CODE	PACKAGING CODE	ADDITIONAL DESCRIPTION

Ambient Operating Temperature Range :-55°C to +125°C

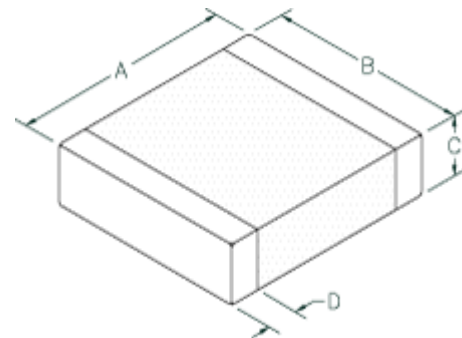

Figure #2

### Drawing Figure #

Figure Number
2

### Electrical Characteristics

NET Z @ 100 MHz	DCR Max	Rated Current mA
--------------------	------------	------------------------

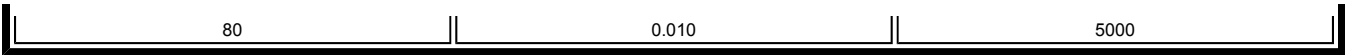

**Physical Dimensions**

A mm	B mm	B1 mm	C mm	C1 mm	D mm	A in	B in	B1 in	C in	C1 in	D in
2.00	1.25	-	0.90	-	0.51	0.079	0.049	-	0.035	-	0.020

**Wire Dimensions**

T1 mm	T2 mm	T1 in	T2 in
-	-	-	-

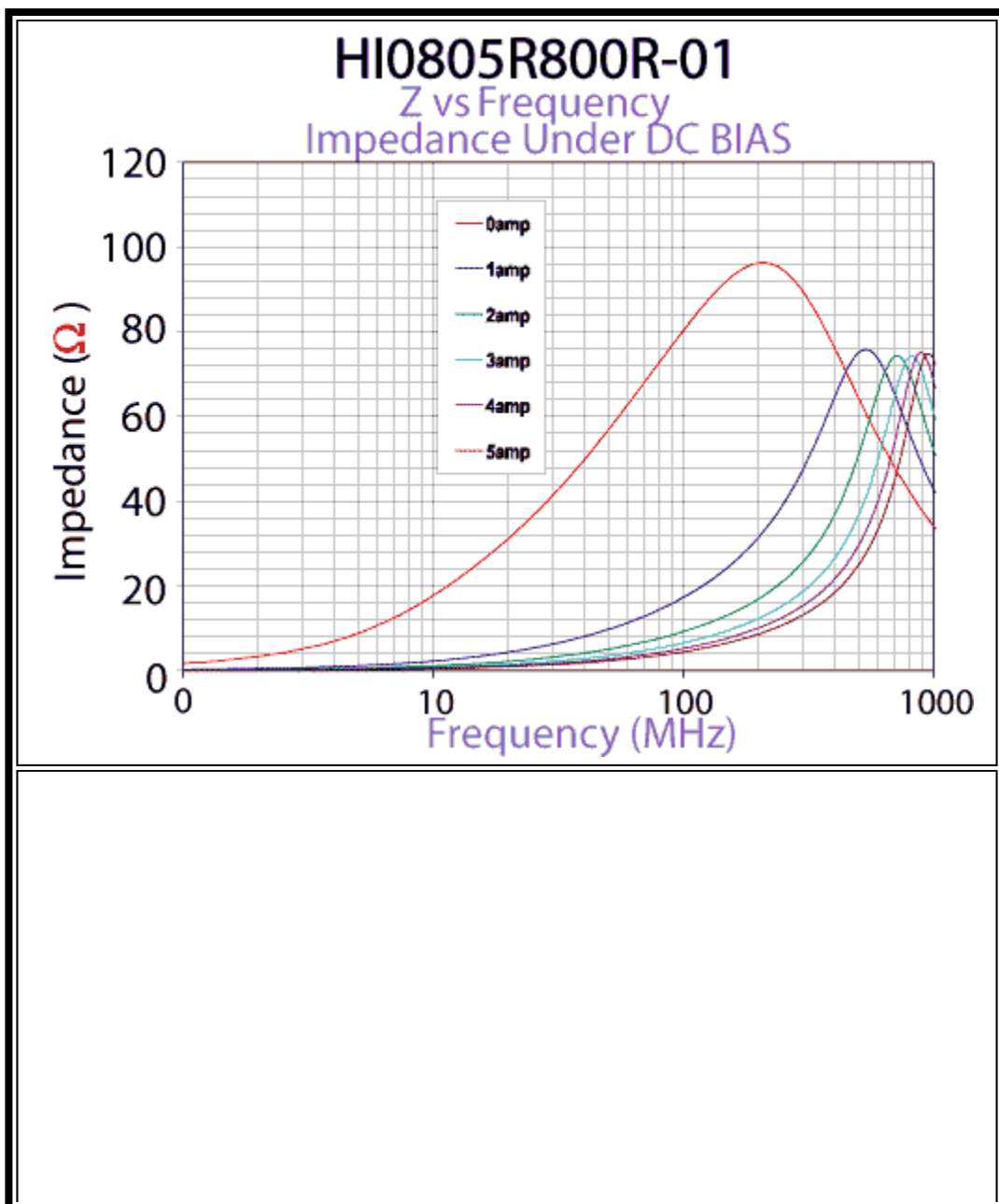

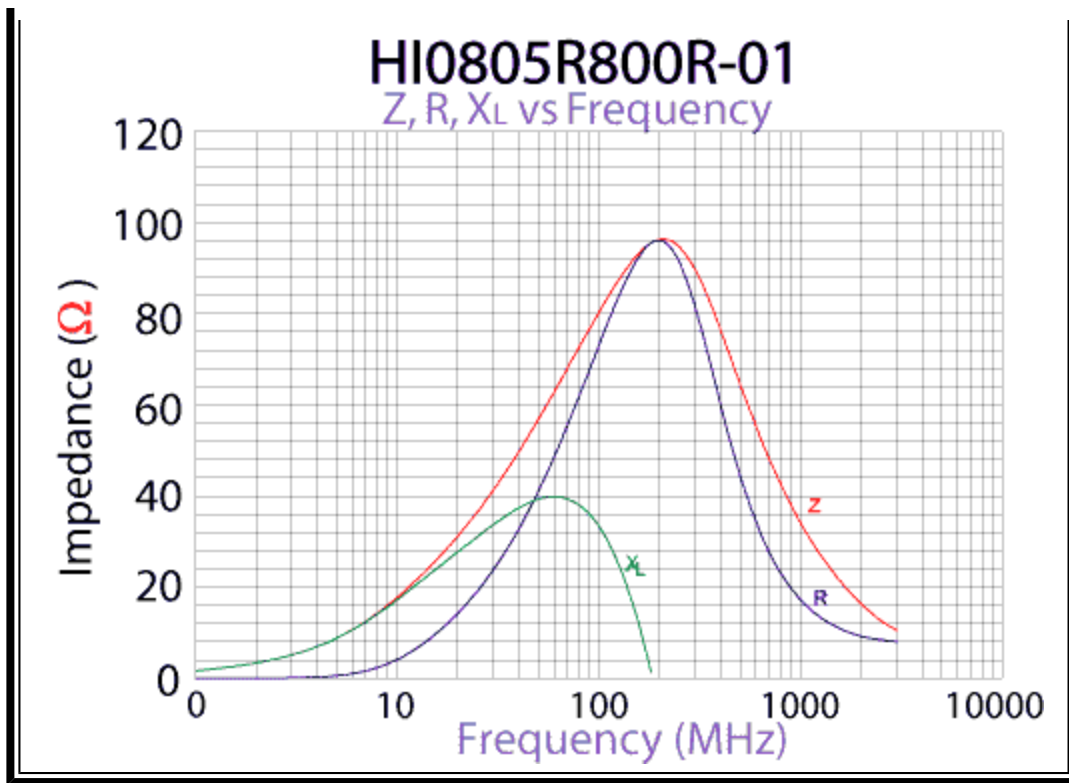

Specifications, which provide more details for the correct use of the described products, are available upon request. All specifications are subject to change without notice. For more information on any of the products listed above, please contact Steward customer service department at (800) 634-2673.

[americas@steward.com](mailto:americas@steward.com)

[mexico@steward.com](mailto:mexico@steward.com)

[europa@steward.com](mailto:europa@steward.com)



[asia@steward.com](mailto:asia@steward.com)

Copyright© 2004 Steward, Inc.

Last Updated: 2/19/2004

## Looking for pricing, stock, or lifecycle information?

Click below to explore more details on WIN SOURCE:

-  [View HI0805R800R-00 on WIN SOURCE](#)
-  [Laird-Signal Integrity Products Information](#)

## Optimize Your Supply Chain with WIN SOURCE Solutions

-  Global Sourcing Solution
-  Obsolete Management
-  Cost Control Management
-  Shortage Management
-  Alternative Solution
-  Excess Inventory Management