



**THE DATASHEET OF  
HI1-0508-5**



## HI-506, HI-507, HI-508, HI-509

Single 16 and 8/Differential 8-Channel and 4-Channel CMOS Analog Multiplexers

FN3142  
Rev 10.00  
Jun 14, 2016

The HI-506/HI-507 and HI-508/HI-509 monolithic CMOS multiplexers each include an array of sixteen and eight analog switches respectively, a digital decoder circuit for channel selection, voltage reference for logic thresholds, and an enable input for device selection when several multiplexers are present. The Dielectric Isolation (DI) process used in fabrication of these devices eliminates the problem of latchup. DI also offers much lower substrate leakage and parasitic capacitance than conventional junction isolated CMOS (see Application Note AN520).

The switching threshold for each digital input is established by an internal +5V reference, providing a guaranteed minimum 2.4V for logic "1" and maximum 0.8V for logic "0". This allows direct interface without pullup resistors to signals from most logic families: CMOS, TTL, DTL and some PMOS. For protection against transient overvoltage, the digital inputs include a series 200Ω resistor and diode clamp to each supply.

The HI-506 is a single 16-channel, the HI-507 is an 8-channel differential, the HI-508 is a single 8-channel and the HI-509 is a 4-channel differential multiplexer.

If input overvoltages are present, the HI-546/HI-547/HI-548/HI-549 multiplexers are recommended.

### Features

- Pb-Free Available (RoHS Compliant) (See Ordering Info)
- Low ON Resistance ..... 180Ω
- Wide Analog Signal Range ..... ±15V
- TTL/CMOS Compatible
- Access Time ..... 250ns
- Maximum Power Supply ..... 44V
- Break-Before-Make Switching
- No Latch-Up
- Replaces DG506A/DG506AA and DG507A/DG507AA
- Replaces DG508A/DG508AA and DG509A/DG509AA

### Applications

- Data Acquisition Systems
- Precision Instrumentation
- Demultiplexing
- Selector Switch

## Ordering Information

PART NUMBER	PART MARKING	TEMP. RANGE (°C)	PACKAGE	PKG. DWG. #
HI1-0506-2	HI1-506-2	-55 to +125	28 Ld CERDIP	F28.6
HI4P0506-5Z (Note 1)	HI4P 506-5Z	0 to +75	28 Ld PLCC (Pb-free)	N28.45
HI9P0506-9Z (Note 1)	HI9P506-9Z	-40 to +85	28 Ld SOIC (Pb-free)	M28.3
HI3-0507-5Z ( <b>No longer available, recommended replacement: HI3-0547-5Z</b> )	HI3-507-5Z	0 to +75	28 Ld PDIP (Note 3) (Pb-free)	E28.6
HI1-0508-2	HI1-508-2	-55 to 125	16 Ld CERDIP	F16.3
HI3-0508-5Z (Note 1)	HI3-508-5Z	0 to +75	16 Ld PDIP (Note 3) (Pb-free)	E16.3
HI9P0508-5Z (Notes 1, 2)	HI9P508-5Z	0 to +75	16 Ld SOIC (Pb-free)	M16.15
HI9P0508-9Z (Note 1)	HI9P508-9Z	-40 to +85	16 Ld SOIC (Pb-free)	M16.15
HI1-0509-2	HI1-509-2	-55 to +125	16 Ld CERDIP	F16.3
HI4P0509-5Z (Notes 1, 2) ( <b>No longer available, recommended replacement: DG409DYZ</b> )	HI4P 509-5Z	0 to +75	20 Ld PLCC (Pb-free)	N20.35

NOTES:

1. These Intersil Pb-free plastic packaged products employ special Pb-free material sets; molding compounds/die attach materials and 100% matte tin plate PLUS ANNEAL - e3 termination finish, which is RoHS compliant and compatible with both SnPb and Pb-free soldering operations. Intersil Pb-free products are MSL classified at Pb-free peak reflow temperatures that meet or exceed the Pb-free requirements of IPC/JEDEC J STD-020.
2. Add "96" suffix for tape and reel. Please refer to TB347 for details on reel specifications.
3. Pb-free PDIPs can be used for through hole wave solder processing only. They are not intended for use in Reflow solder processing applications.

**Pinouts**

**HI-506 (CERDIP, SOIC)**  
TOP VIEW

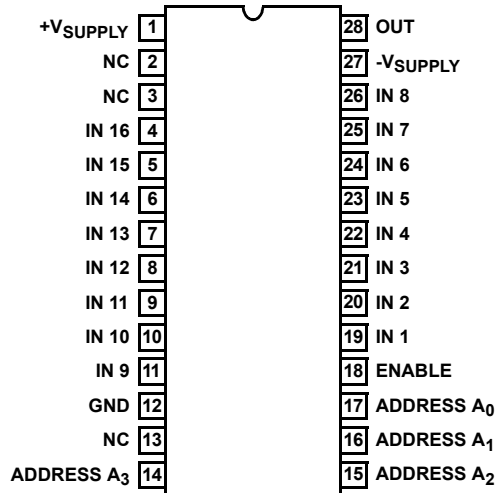

**HI-506 (PLCC)**  
TOP VIEW

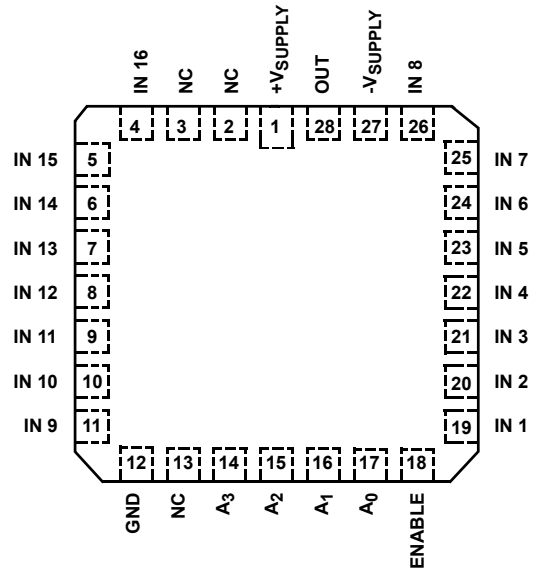

**HI-507 (PDIP, CERDIP)**  
TOP VIEW

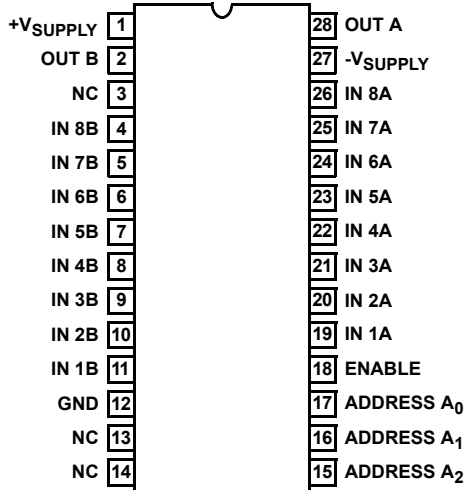

**HI-508 (PDIP, CERDIP, SOIC)**  
TOP VIEW

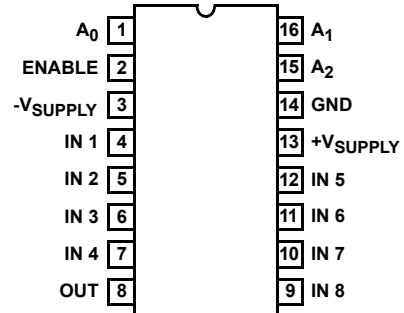

**Pinouts** (Continued)

**HI-509 (PDIP, CERDIP, SOIC)**  
TOP VIEW

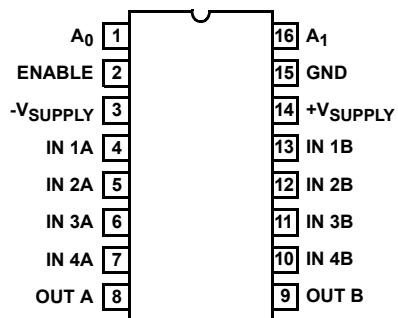

**HI-509 (PLCC)**  
TOP VIEW

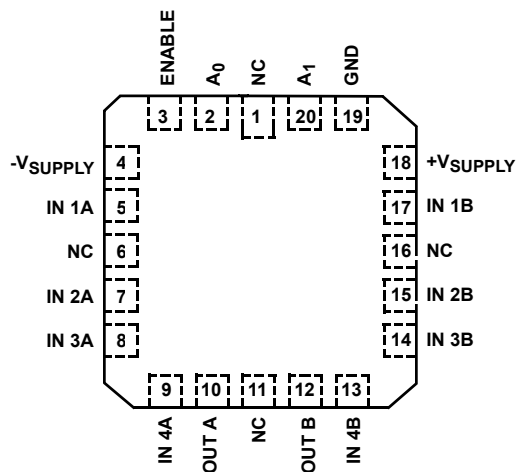

**Truth Tables**

**HI-506**

A <sub>3</sub>	A <sub>2</sub>	A <sub>1</sub>	A <sub>0</sub>	EN	"ON" CHANNEL
X	X	X	X	L	None
L	L	L	L	H	1
L	L	L	H	H	2
L	L	H	L	H	3
L	L	H	H	H	4
L	H	L	L	H	5
L	H	L	H	H	6
L	H	H	L	H	7
L	H	H	H	H	8
H	L	L	L	H	9
H	L	L	H	H	10
H	L	H	L	H	11
H	L	H	H	H	12
H	H	L	L	H	13
H	H	L	H	H	14
H	H	H	L	H	15
H	H	H	H	H	16

**HI-508**

A <sub>2</sub>	A <sub>1</sub>	A <sub>0</sub>	EN	"ON" CHANNEL
X	X	X	L	None
L	L	L	H	1
L	L	H	H	2
L	H	L	H	3
L	H	H	H	4
H	L	L	H	5
H	L	H	H	6
H	H	L	H	7
H	H	H	H	8

**HI-509**

A <sub>1</sub>	A <sub>0</sub>	EN	"ON" CHANNEL PAIR
X	X	L	None
L	L	H	1
L	H	H	2
H	L	H	3
H	H	H	4

**HI-507**

A <sub>2</sub>	A <sub>1</sub>	A <sub>0</sub>	EN	"ON" CHANNEL
X	X	X	L	None
L	L	L	H	1
L	L	H	H	2
L	H	L	H	3
L	H	H	H	4
H	L	L	H	5
H	L	H	H	6
H	H	L	H	7
H	H	H	H	8

**Functional Diagrams**

HI-506

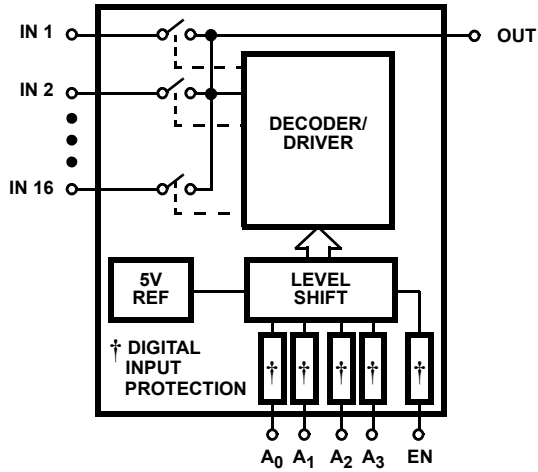

HI-507

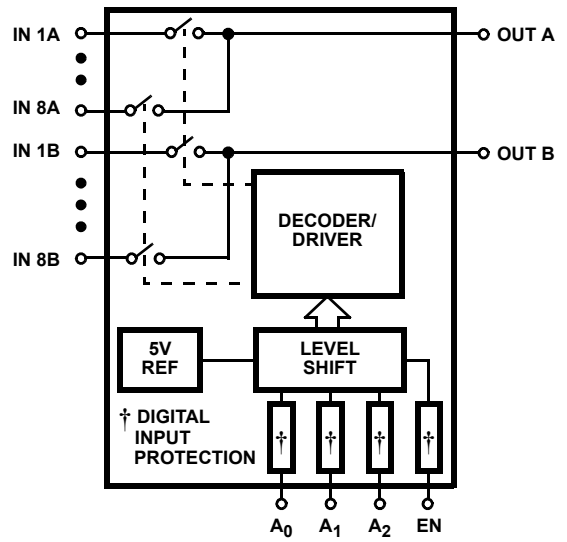

HI-508

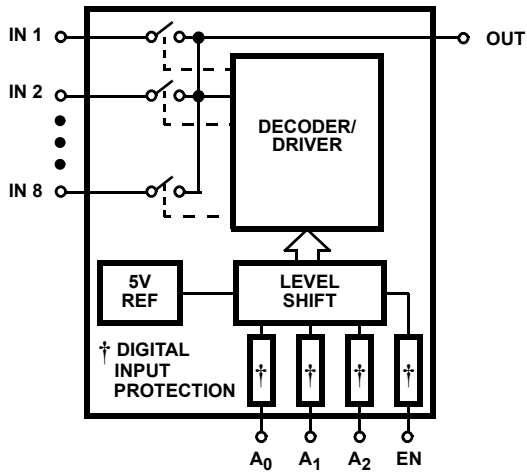

HI-509

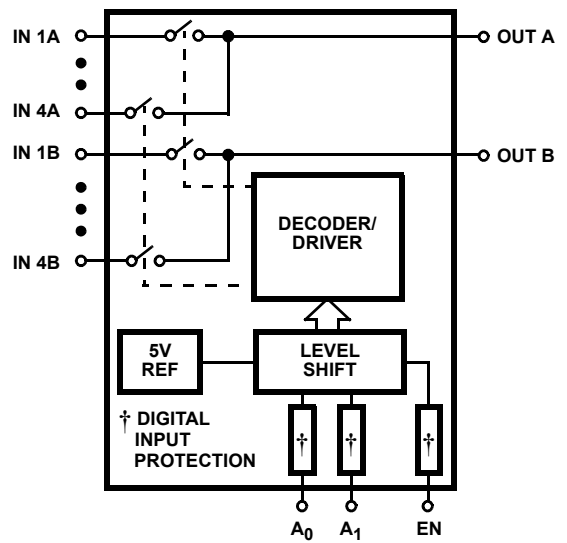

**Schematic Diagrams**

**ADDRESS DECODER**

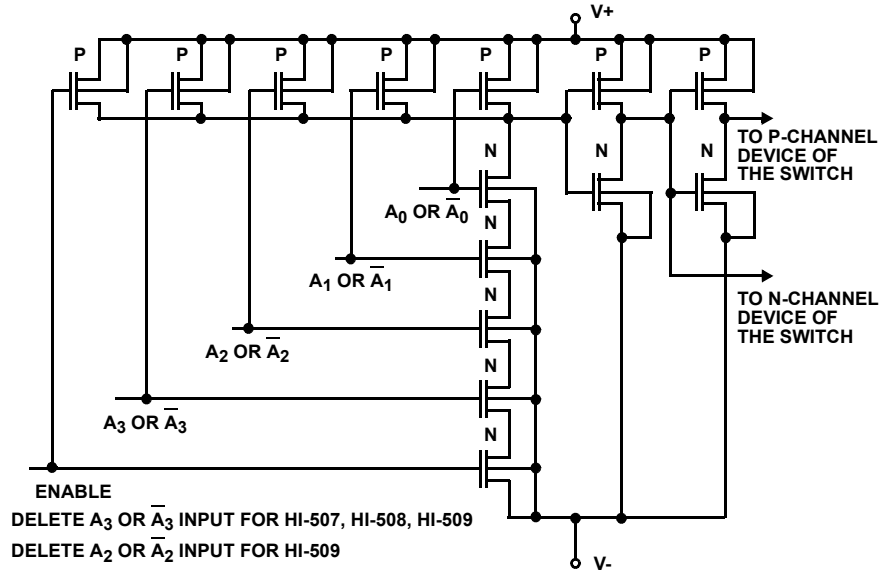

**ADDRESS INPUT BUFFER LEVEL SHIFTER**

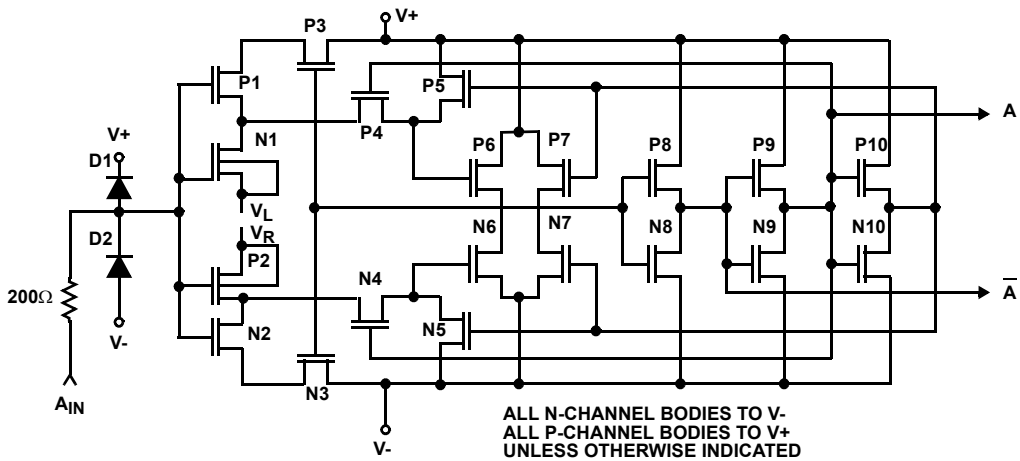

**TTL REFERENCE CIRCUIT**

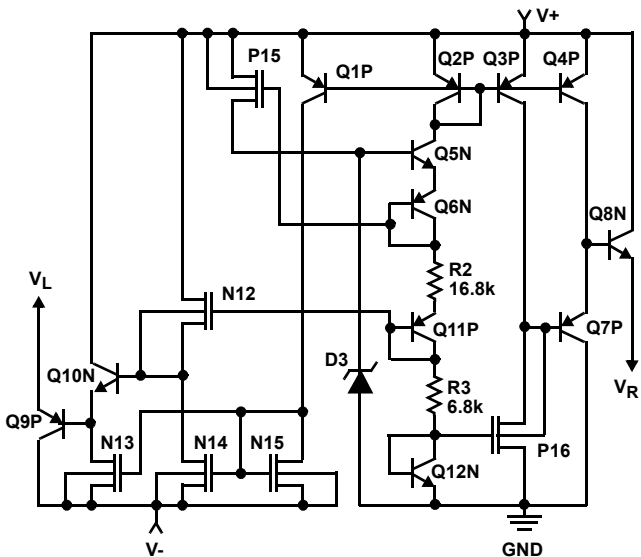

**MULTIPLEX SWITCH**

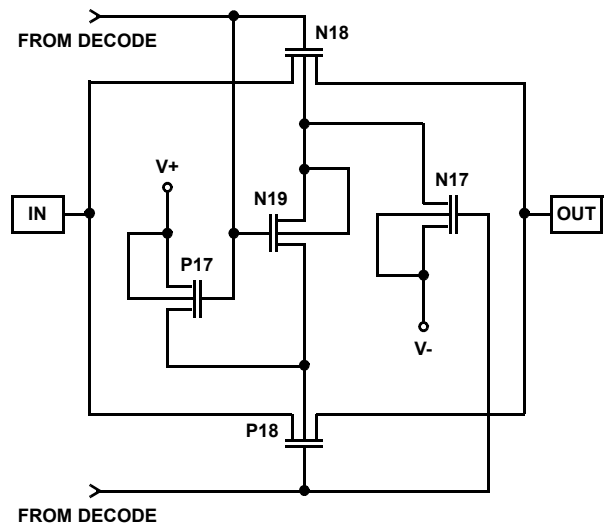

**Absolute Maximum Ratings**

V+ to V-	+44V
V+ to GND	+22V
V- to GND	-25V
Digital Input Voltage (V <sub>EN</sub> , V <sub>A</sub> )	(V-) -4V to (V+) +4V or 20mA, Whichever Occurs First
Analog Signal (V <sub>IN</sub> , V <sub>OUT</sub> , Note 5)	(V-) -2V to (V+) +2V
Continuous Current, In or Out	20mA
Peak Current, In or Out (Pulsed 1ms, 10% Duty Cycle Max)	40mA

**Operating Conditions**

Temperature Ranges	
HI-50X-2	-55°C to +125°C
HI-50X-4	-25°C to +85°C
HI-50X-5	0°C to +75°C
HI-50X-9	-40°C to +85°C
Typical Minimum Supply Voltage	±10V or Single 20V

**Thermal Information**

Thermal Resistance (Typical, Note 4)	$\theta_{JA}$ (°C/W)	$\theta_{JC}$ (°C/W)
16 Ld CERDIP Package	85	32
16 Ld SOIC Package	115	N/A
16 Ld PDIP Package	100	N/A
20 Ld PLCC Package	80	N/A
28 Ld CERDIP Package	55	18
28 Ld PDIP Package	60	N/A
28 Ld SOIC Package	70	N/A
28 Ld PLCC Package	70	N/A
Maximum Junction Temperature		
Ceramic Packages	+175°C	
Plastic Packages	+150°C	
Maximum Storage Temperature Range	-65°C to +150°C	
Pb-free reflow profile	.see link below <a href="http://www.intersil.com/pbfree/Pb-FreeReflow.asp">http://www.intersil.com/pbfree/Pb-FreeReflow.asp</a>	

*CAUTION: Do not operate at or near the maximum ratings listed for extended periods of time. Exposure to such conditions may adversely impact product reliability and result in failures not covered by warranty.*

**NOTE:**

- $\theta_{JA}$  is measured with the component mounted on a low effective thermal conductivity test board in free air. See Tech Brief TB379 for details.
- Signals on IN or OUT exceeding V+ or V- are clamped by internal diodes. Limit resulting current to maximum current ratings. If an overvoltage condition is anticipated (analog input exceeds either power supply voltage), the Intersil HI-546/HI-547/HI-548/HI-549 multiplexers are recommended.

**Electrical Specifications**

Supplies = +15V, -15V; V<sub>AH</sub> (Logic Level High) = 2.4V; V<sub>AL</sub> (Logic Level Low) = 0.8V, Unless Otherwise Specified. For Test Conditions, Consult Test Circuits Section

PARAMETER	TEST CONDITIONS	TEMP (°C)	-2			-4, -5, -9			UNITS
			MIN (Note 11)	TYP	MAX	MIN (Note 11)	TYP	MAX	
<b>DYNAMIC CHARACTERISTICS</b>									
Access Time, t <sub>A</sub>		25	-	250	500	-	250	-	ns
		Full	-	-	1000	-	-	1000	ns
Break-Before-Make Delay, t <sub>OPEN</sub>		25	25	80	-	25	80	-	ns
Enable Delay (ON), t <sub>ON(EN)</sub>		25	-	250	500	-	250	-	ns
		Full	-	-	1000	-	-	1000	ns
Enable Delay (OFF), t <sub>OFF(EN)</sub>		25	-	250	500	-	250	-	ns
		Full	-	-	1000	-	-	1000	ns
Settling Time, t <sub>S</sub> (HI-506 and HI-507)	To 0.1%	25	-	1.2	-	-	1.2	-	µs
	To 0.01%	25	-	2.4	-	-	2.4	-	µs
Settling Time, t <sub>S</sub> (HI-508 and HI-509)	To 0.1%	25	-	360	-	-	360	-	ns
	To 0.01%	25	-	600	-	-	600	-	ns
Off Isolation	Note 9	25	-	68	-	-	68	-	dB
Channel Input Capacitance, C <sub>S(OFF)</sub>		25	-	10	-	-	10	-	pF
Channel Output Capacitance, C <sub>D(OFF)</sub>	HI-506	25	-	52	-	-	52	-	pF
	HI-507	25	-	30	-	-	30	-	pF
	HI-508	25	-	17	-	-	17	-	pF
	HI-509	25	-	12	-	-	12	-	pF
Digital Input Capacitance, C <sub>A</sub>		25	-	6	-	-	6	-	pF
Input to Output Capacitance, C <sub>DS(OFF)</sub>		25	-	0.08	-	-	0.08	-	pF
<b>DIGITAL INPUT CHARACTERISTICS</b>									
Input Low Threshold, V <sub>AL</sub>		Full	-	-	0.8	-	-	0.8	V
Input High Threshold, V <sub>AH</sub>		Full	2.4	-	-	2.4	-	-	V

**Electrical Specifications** Supplies = +15V, -15V;  $V_{AH}$  (Logic Level High) = 2.4V;  $V_{AL}$  (Logic Level Low) = 0.8V, Unless Otherwise Specified. For Test Conditions, Consult Test Circuits Section **(Continued)**

PARAMETER	TEST CONDITIONS	TEMP (°C)	-2			-4, -5, -9			UNITS
			MIN (Note 11)	TYP	MAX	MIN (Note 11)	TYP	MAX	
Input Leakage Current (High or Low), $I_A$	Note 8	Full	-	-	1.0	-	-	1.0	$\mu$ A
<b>ANALOG CHANNEL CHARACTERISTICS</b>									
Analog Signal Range, $V_{IN}$		Full	-15	-	+15	-15	-	+15	V
On Resistance, $r_{ON}$	Note 6	25	-	180	300	-	180	400	$\Omega$
$\Delta r_{ON}$ , (Any Two Channels)		25	-	5	-	-	5	-	%
Off Input Leakage Current, $I_{S(OFF)}$	Note 7	25	-	0.03	-	-	0.03	-	nA
		Full	-	-	50	-	-	50	nA
Off Output Leakage Current, $I_{D(OFF)}$	Note 7	25	-	0.3	-	-	0.3	-	nA
		Full	-	-	300	-	-	300	nA
		Full	-	-	200	-	-	200	nA
		Full	-	-	200	-	-	200	nA
		Full	-	-	100	-	-	100	nA
On Channel Leakage Current, $I_{D(ON)}$	Note 7	25	-	0.3	-	-	0.3	-	nA
		Full	-	-	300	-	-	300	nA
		Full	-	-	200	-	-	200	nA
		Full	-	-	200	-	-	200	nA
		Full	-	-	100	-	-	100	nA
Differential Off Output Leakage Current, $I_{DIFF}$ (HI-507, HI-509 Only)		Full	-	-	50	-	-	50	nA
<b>POWER SUPPLY CHARACTERISTICS</b>									
Current, $I_+$	Note 10	Full	-	1.5	3.0	-	1.5	3.0	mA
	Note 10	Full	-	1.5	2.4	-	1.5	2.4	mA
Current, $I_-$	Note 10	Full	-	0.4	1.0	-	0.4	1.0	mA
	Note 10	Full	-	0.4	1.0	-	0.4	1.0	mA
Power Dissipation, $P_D$		Full	-	-	60	-	-	60	mW
		Full	-	-	51	-	-	51	mW

NOTES:

6.  $V_{OUT} = \pm 10V$ ,  $I_{OUT} = \bar{7}1mA$ .
7. 10nA is the practical lower limit for high speed measurement in the production test environment.
8. Digital input leakage is primarily due to the clamp diodes (see Schematic). Typical leakage is less than 1nA at +25°C.
9.  $V_{EN} = 0.8V$ ,  $R_L = 1k$ ,  $C_L = 15pF$ ,  $V_S = 7V_{RMS}$ ,  $f = 100kHz$ .
10.  $V_{EN}$ ,  $V_A = 0V$  or 2.4V.
11. Parts are 100% tested at +25°C. Over-temperature limits established by characterization and are not production tested.

**Test Circuits and Waveforms**  $T_A = +25^\circ\text{C}$ ,  $V_{\text{SUPPLY}} = \pm 15\text{V}$ ,  $V_{\text{AH}} = 2.4\text{V}$ ,  $V_{\text{AL}} = 0.8\text{V}$ , Unless Otherwise Specified

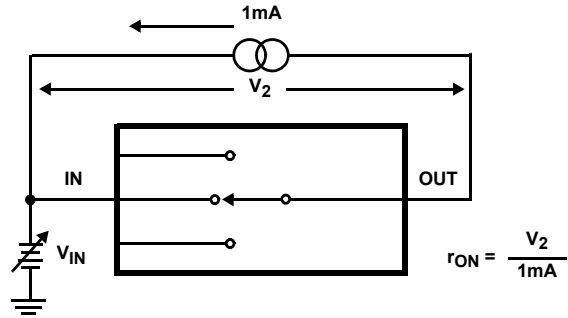

FIGURE 1A. TEST CIRCUIT

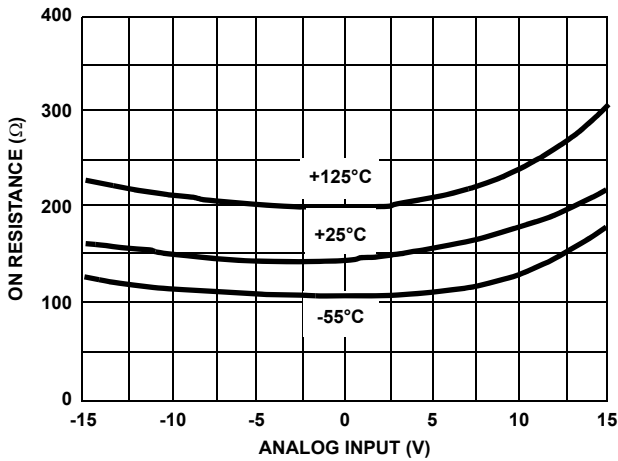

FIGURE 1B. ON RESISTANCE vs ANALOG INPUT VOLTAGE

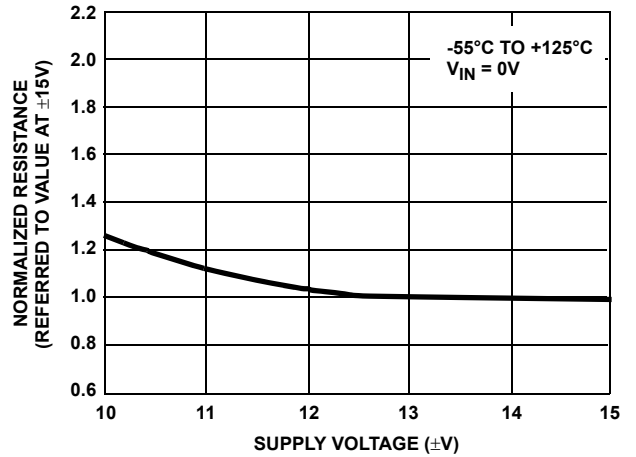

FIGURE 1C. NORMALIZED ON RESISTANCE vs SUPPLY VOLTAGE

FIGURE 1. ON RESISTANCE

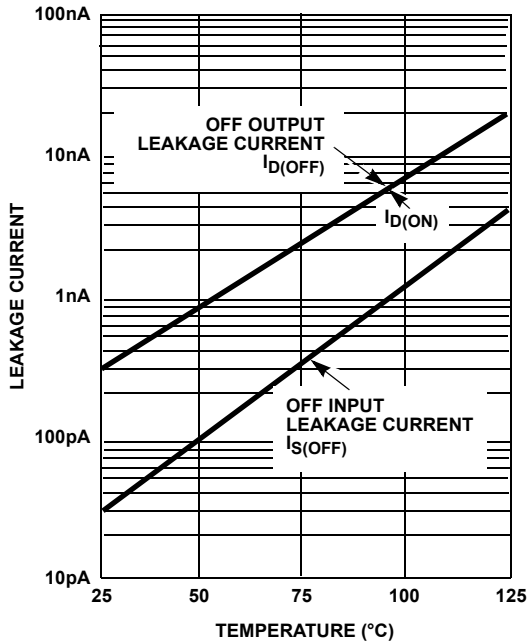

FIGURE 2A. LEAKAGE CURRENT vs TEMPERATURE

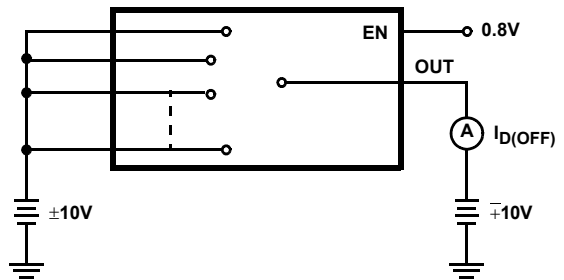

FIGURE 2B.  $I_{D(OFF)}$  TEST CIRCUIT (NOTE 12)

**Test Circuits and Waveforms**  $T_A = +25^\circ\text{C}$ ,  $V_{\text{SUPPLY}} = \pm 15\text{V}$ ,  $V_{\text{AH}} = 2.4\text{V}$ ,  $V_{\text{AL}} = 0.8\text{V}$ , Unless Otherwise Specified (Continued)

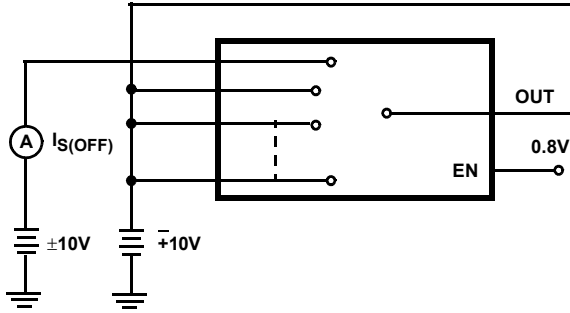

FIGURE 2C.  $I_{\text{S(OFF)}}$  TEST CIRCUIT (NOTE 12)

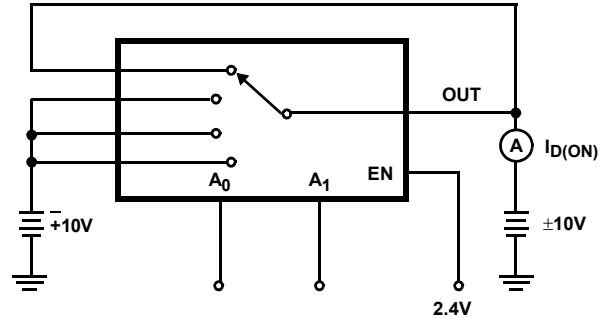

FIGURE 2D.  $I_{\text{D(ON)}}$  TEST CIRCUIT (NOTE 12)

FIGURE 2. LEAKAGE CURRENTS

NOTE:

12. Two measurements per channel:  $\pm 10\text{V}$  and  $\mp 10\text{V}$ . (Two measurements per device for  $I_{\text{D(OFF)}}$   $\pm 10\text{V}$  and  $\mp 10\text{V}$ )

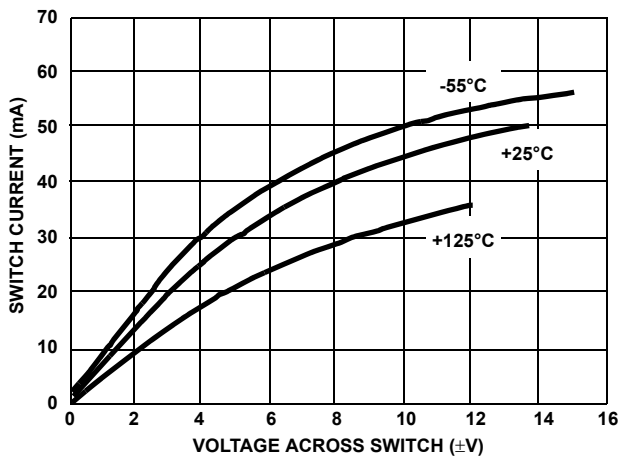

FIGURE 3A. ON CHANNEL CURRENT vs VOLTAGE

FIGURE 3. ON CHANNEL CURRENT

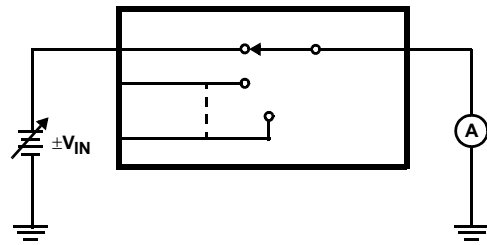

FIGURE 3B. TEST CIRCUIT

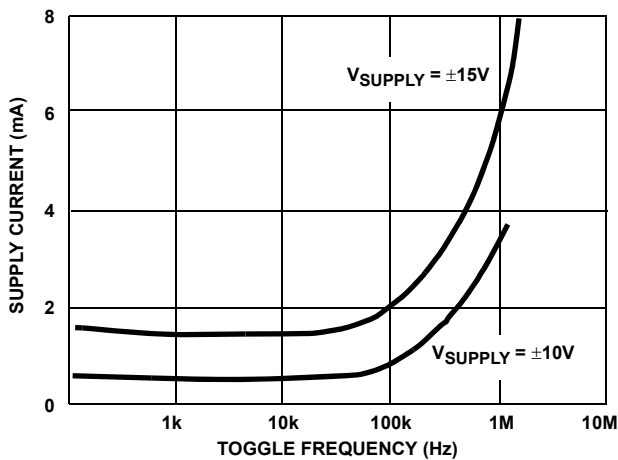

FIGURE 4A. SUPPLY CURRENT vs TOGGLE FREQUENCY

FIGURE 4. DYNAMIC SUPPLY CURRENT

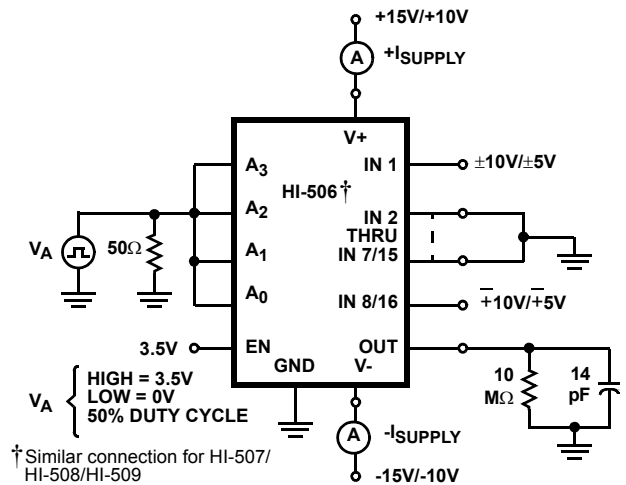

FIGURE 4B. TEST CIRCUIT

† Similar connection for HI-507/ HI-508/ HI-509

**Test Circuits and Waveforms**  $T_A = +25^\circ\text{C}$ ,  $V_{\text{SUPPLY}} = \pm 15\text{V}$ ,  $V_{\text{AH}} = 2.4\text{V}$ ,  $V_{\text{AL}} = 0.8\text{V}$ , Unless Otherwise Specified (Continued)

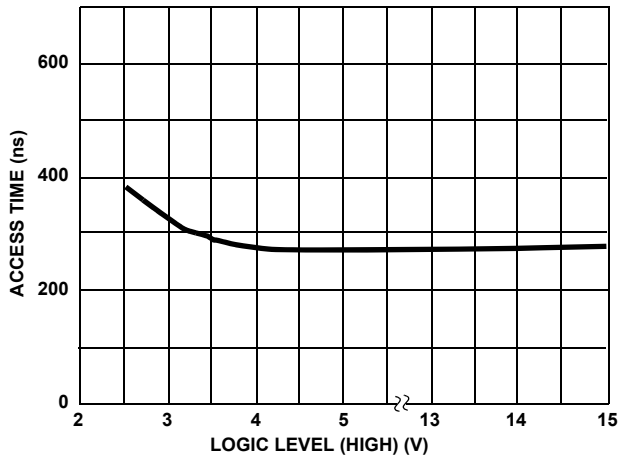
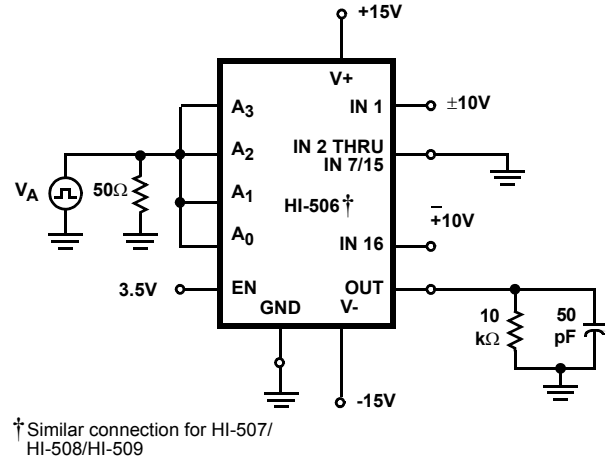

FIGURE 5A. ACCESS TIME vs LOGIC LEVEL (HIGH)



† Similar connection for HI-507/  
HI-508/HI-509

FIGURE 5B. TEST CIRCUIT

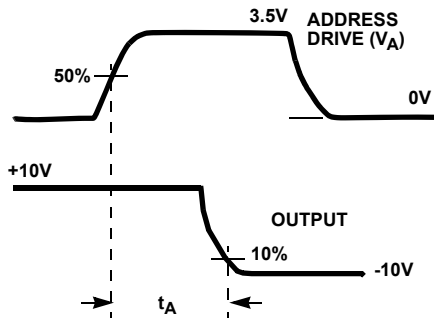

FIGURE 5C. MEASUREMENT POINTS

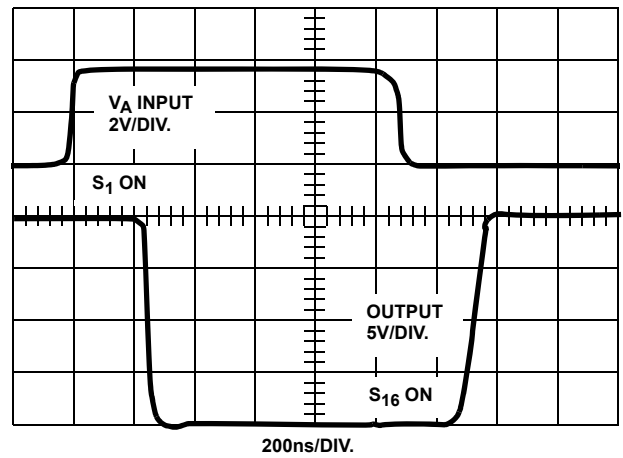
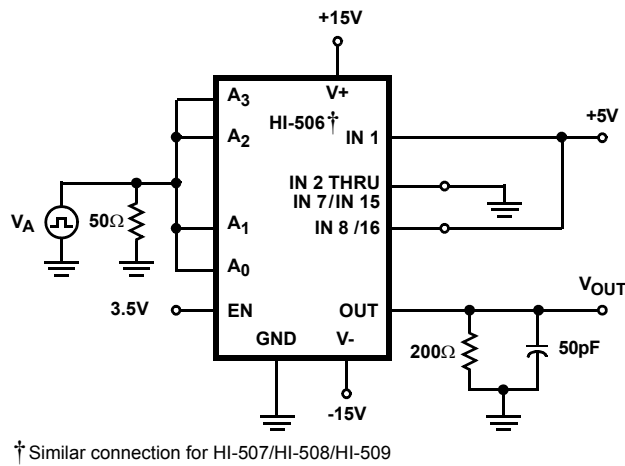

FIGURE 5D. WAVEFORMS

FIGURE 5. ACCESS TIME



† Similar connection for HI-507/HI-508/HI-509

FIGURE 6A. TEST CIRCUIT

**Test Circuits and Waveforms**  $T_A = +25^\circ\text{C}$ ,  $V_{\text{SUPPLY}} = \pm 15\text{V}$ ,  $V_{\text{AH}} = 2.4\text{V}$ ,  $V_{\text{AL}} = 0.8\text{V}$ , Unless Otherwise Specified (Continued)

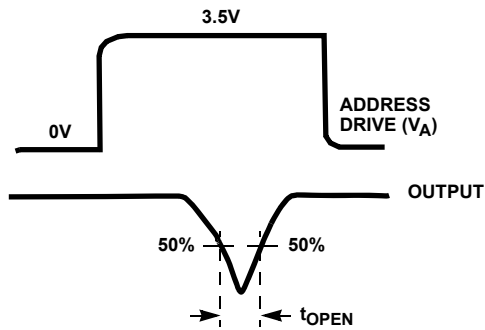

FIGURE 6B. MEASUREMENT POINTS

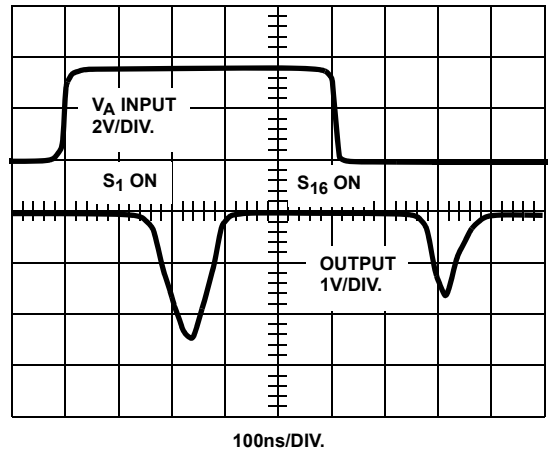

FIGURE 6C. WAVEFORMS

FIGURE 6. BREAK-BEFORE-MAKE DELAY

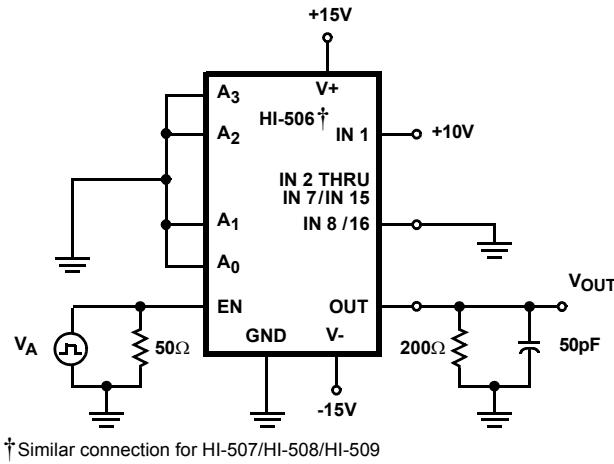

FIGURE 7A. TEST CIRCUIT

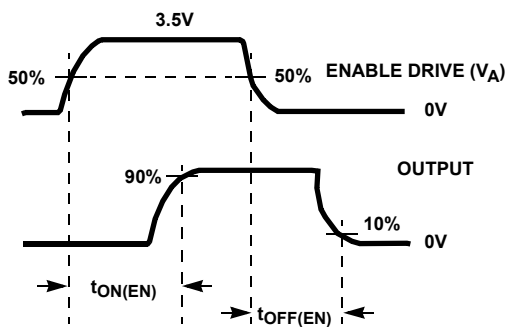

FIGURE 7B. MEASUREMENT POINTS

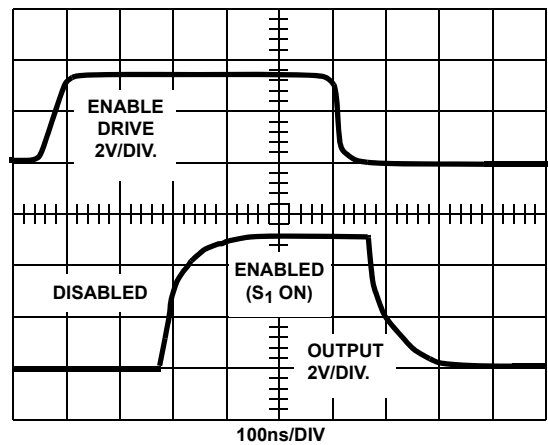

FIGURE 7C. WAVEFORMS

FIGURE 7. ENABLE DELAYS

**Typical Performance Curves**  $T_A = 25^\circ\text{C}$ ,  $V_{\text{SUPPLY}} = \pm 15\text{V}$ ,  $V_{\text{AH}} = 2.4\text{V}$ ,  $V_{\text{AL}} = 0.8\text{V}$ , Unless Otherwise Specified

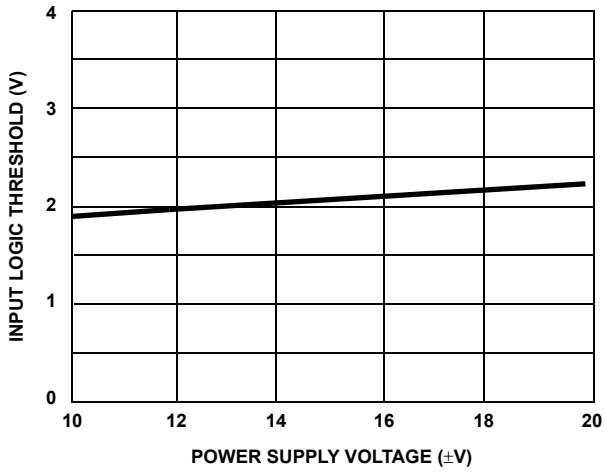

FIGURE 8. LOGIC THRESHOLD vs POWER SUPPLY VOLTAGE

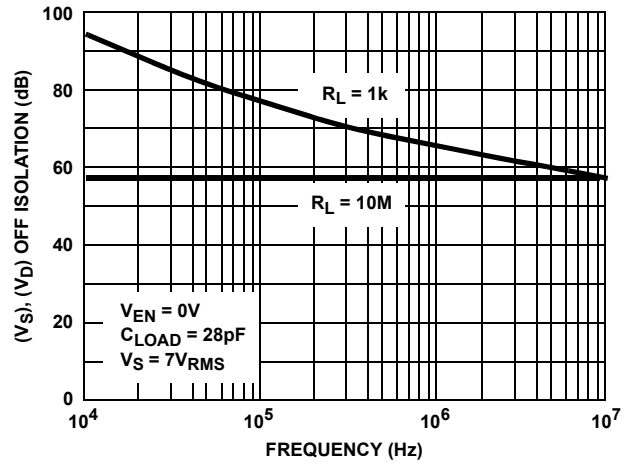

FIGURE 9. OFF ISOLATION vs FREQUENCY

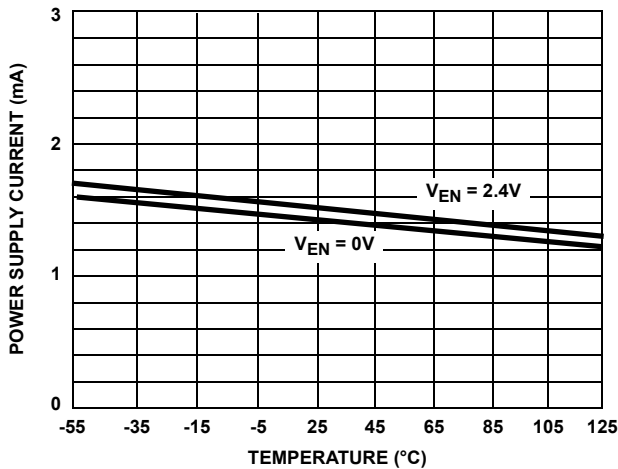

FIGURE 10A. HI-506/HI-507

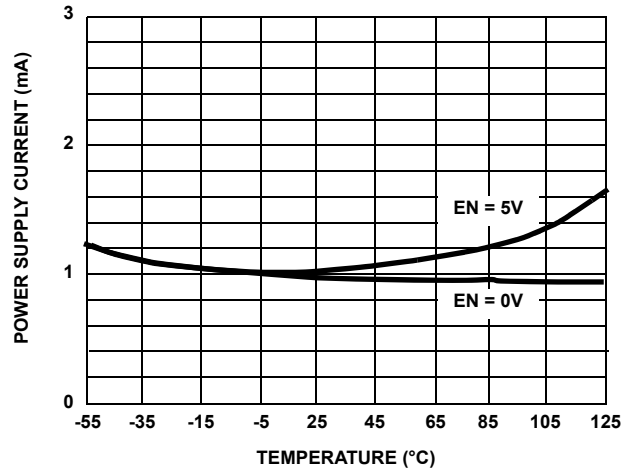

FIGURE 10B. HI-508/HI-509

FIGURE 10. POWER SUPPLY CURRENT vs TEMPERATURE

## Die Characteristics

### METALLIZATION:

Type: CuAl  
 Thickness:  $16\text{k}\text{\AA} \pm 2\text{k}\text{\AA}$

### SUBSTRATE POTENTIAL (NOTE):

$-V_{\text{SUPPLY}}$

### PASSIVATION:

Type: Nitride/Silox  
 Nitride Thickness:  $3.5\text{k}\text{\AA} \pm 1\text{k}\text{\AA}$   
 Silox Thickness:  $12\text{k}\text{\AA} \pm 2\text{k}\text{\AA}$

### WORST CASE CURRENT DENSITY:

$1.4 \times 10^5 \text{ A/cm}^2$

### TRANSISTOR COUNT:

421

### PROCESS:

CMOS-DI

NOTE: The substrate appears resistive to the  $-V_{\text{SUPPLY}}$  terminal, therefore it may be left floating (Insulating Die Mount) or it may be mounted on a conductor at  $-V_{\text{SUPPLY}}$  potential.

## Metallization Mask Layout

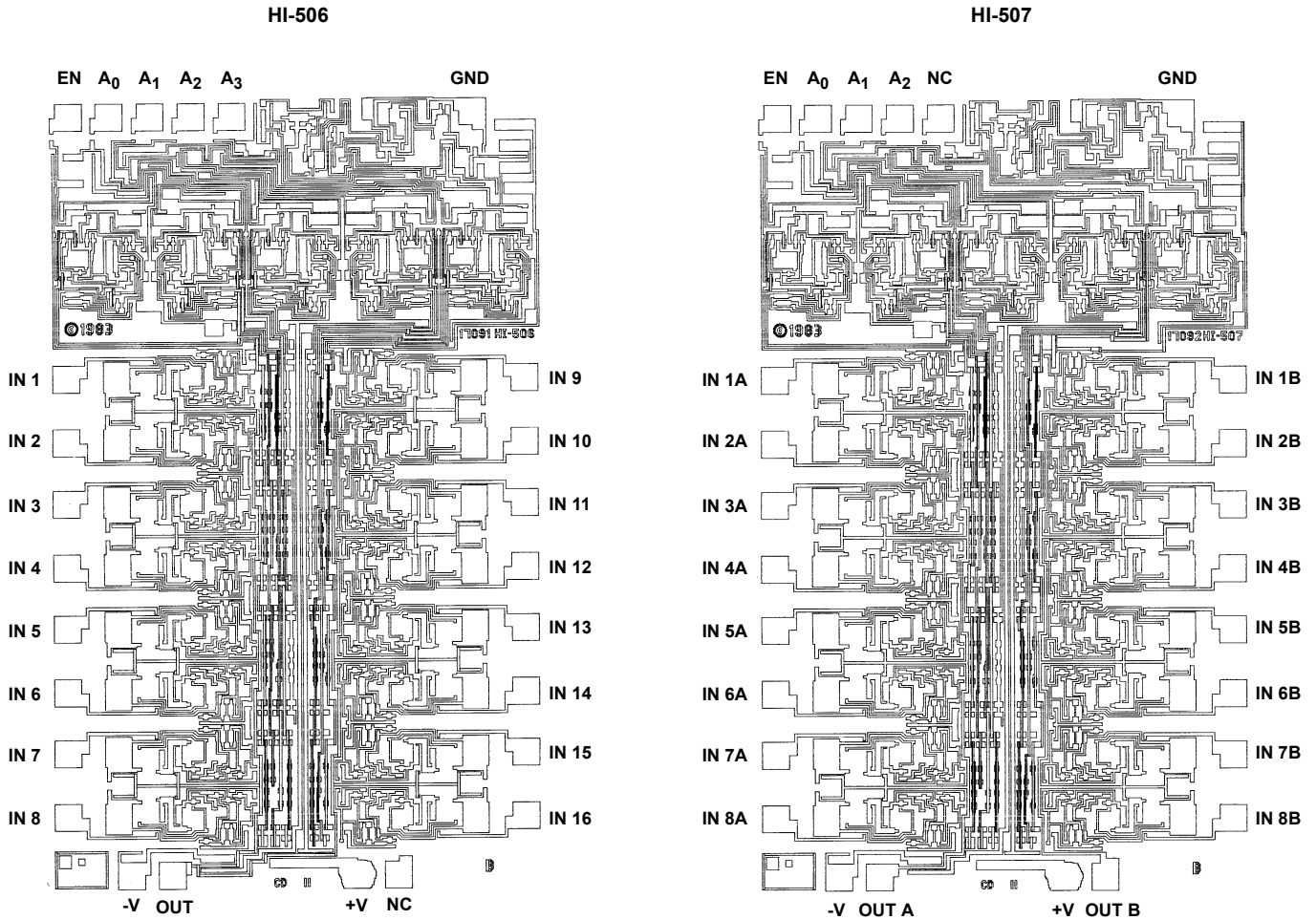

## Die Characteristics

### METALLIZATION:

Type: CuAl  
 Thickness:  $16\text{k}\text{\AA} \pm 2\text{k}\text{\AA}$

### SUBSTRATE POTENTIAL (NOTE):

$-V_{\text{SUPPLY}}$

### PASSIVATION:

Type: Nitride/Silox  
 Nitride Thickness:  $3.5\text{k}\text{\AA} \pm 1\text{k}\text{\AA}$   
 Silox Thickness:  $12\text{k}\text{\AA} \pm 2\text{k}\text{\AA}$

### WORST CASE CURRENT DENSITY:

$1.4 \times 10^5 \text{ A/cm}^2$

### TRANSISTOR COUNT:

234

### PROCESS:

CMOS-DI

NOTE: The substrate appears resistive to the  $-V_{\text{SUPPLY}}$  terminal, therefore it may be left floating (Insulating Die Mount) or it may be mounted on a conductor at  $-V_{\text{SUPPLY}}$  potential.

## Metallization Mask Layout

HI-508

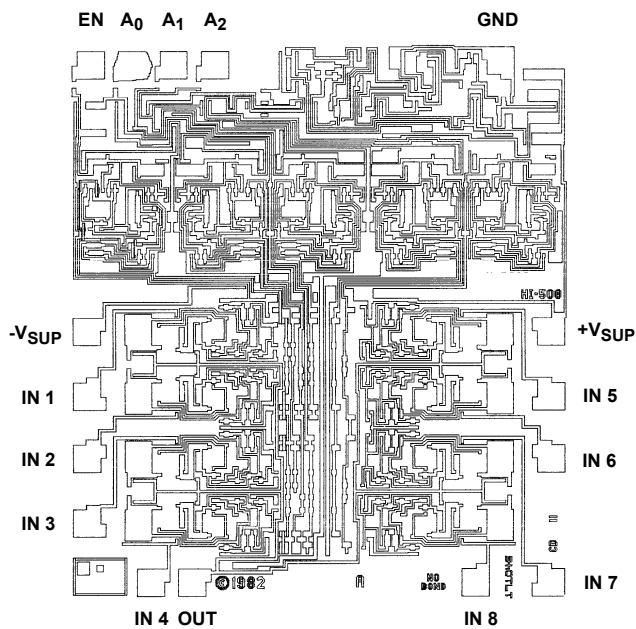

HI-509

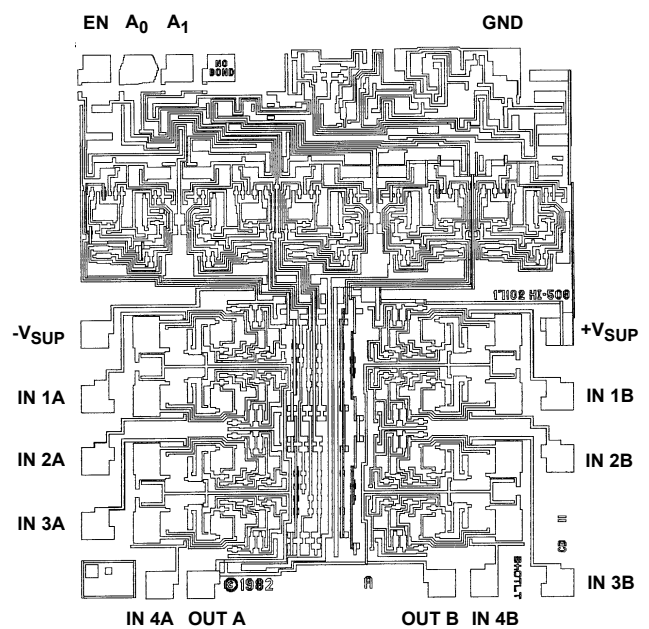

## Revision History

The revision history provided is for informational purposes only and is believed to be accurate, but not warranted. Please go to the web to make sure that you have the latest revision.

DATE	REVISION	CHANGE
May 24, 2016	FN3142.10	Updated ordering information table on page 2.
August 7, 2015	FN3142.9	Updated ordering information table on page 2. Added Revision History and About Intersil sections. Updated M28.3 to most recent revision with change as follows: Added land pattern

## About Intersil

Intersil Corporation is a leading provider of innovative power management and precision analog solutions. The company's products address some of the largest markets within the industrial and infrastructure, mobile computing and high-end consumer markets.

For the most updated datasheet, application notes, related documentation and related parts, please see the respective product information page found at [www.intersil.com](http://www.intersil.com).

You may report errors or suggestions for improving this datasheet by visiting [www.intersil.com/ask](http://www.intersil.com/ask).

Reliability reports are also available from our website at [www.intersil.com/support](http://www.intersil.com/support)

### Dual-In-Line Plastic Packages (PDIP)

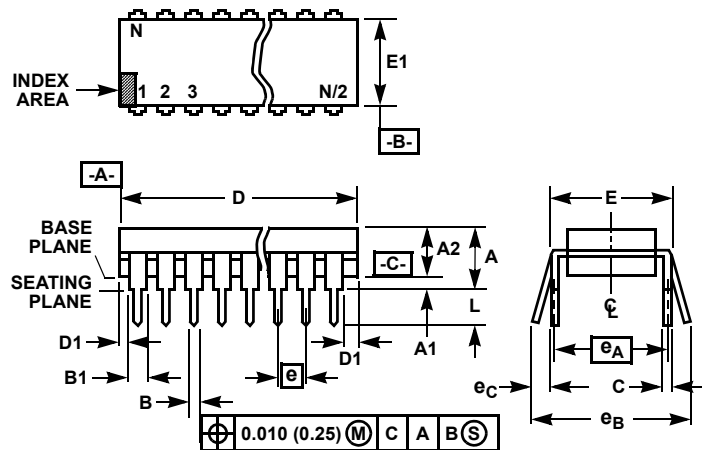

**NOTES:**

1. Controlling Dimensions: INCH. In case of conflict between English and Metric dimensions, the inch dimensions control.
2. Dimensioning and tolerancing per ANSI Y14.5M-1982.
3. Symbols are defined in the "MO Series Symbol List" in Section 2.2 of Publication No. 95.
4. Dimensions A, A1 and L are measured with the package seated in JEDEC seating plane gauge GS-3.
5. D, D1, and E1 dimensions do not include mold flash or protrusions. Mold flash or protrusions shall not exceed 0.010 inch (0.25mm).
6. E and  $e_A$  are measured with the leads constrained to be perpendicular to datum [-C-].
7.  $e_B$  and  $e_C$  are measured at the lead tips with the leads unconstrained.  $e_C$  must be zero or greater.
8. B1 maximum dimensions do not include dambar protrusions. Dambar protrusions shall not exceed 0.010 inch (0.25mm).
9. N is the maximum number of terminal positions.
10. Corner leads (1, N, N/2 and N/2 + 1) for E8.3, E16.3, E18.3, E28.3, E42.6 will have a B1 dimension of 0.030 - 0.045 inch (0.76 - 1.14mm).

**E16.3 (JEDEC MS-001-BB ISSUE D)  
16 LEAD DUAL-IN-LINE PLASTIC PACKAGE**

SYMBOL	INCHES		MILLIMETERS		NOTES
	MIN	MAX	MIN	MAX	
A	-	0.210	-	5.33	4
A1	0.015	-	0.39	-	4
A2	0.115	0.195	2.93	4.95	-
B	0.014	0.022	0.356	0.558	-
B1	0.045	0.070	1.15	1.77	8, 10
C	0.008	0.014	0.204	0.355	-
D	0.735	0.775	18.66	19.68	5
D1	0.005	-	0.13	-	5
E	0.300	0.325	7.62	8.25	6
E1	0.240	0.280	6.10	7.11	5
e	0.100 BSC		2.54 BSC		-
$e_A$	0.300 BSC		7.62 BSC		6
$e_B$	-	0.430	-	10.92	7
L	0.115	0.150	2.93	3.81	4
N	16		16		9

Rev. 0 12/93

**Dual-In-Line Plastic Packages (PDIP)**

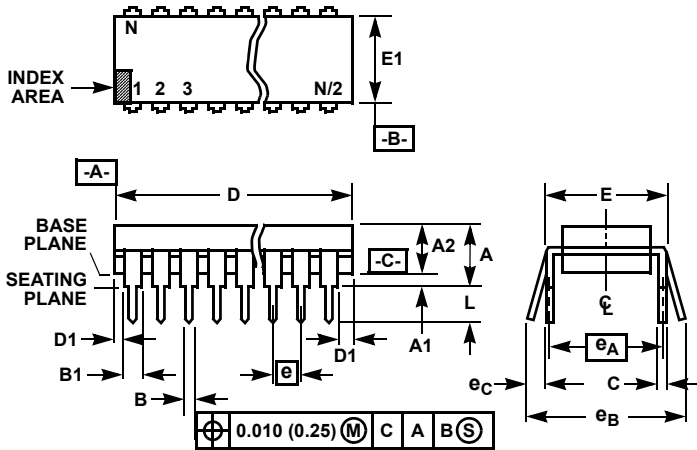

**NOTES:**

1. Controlling Dimensions: INCH. In case of conflict between English and Metric dimensions, the inch dimensions control.
2. Dimensioning and tolerancing per ANSI Y14.5M-1982.
3. Symbols are defined in the "MO Series Symbol List" in Section 2.2 of Publication No. 95.
4. Dimensions A, A1 and L are measured with the package seated in JEDEC seating plane gauge GS-3.
5. D, D1, and E1 dimensions do not include mold flash or protrusions. Mold flash or protrusions shall not exceed 0.010 inch (0.25mm).
6. E and  $e_A$  are measured with the leads constrained to be perpendicular to datum  $-C-$ .
7.  $e_B$  and  $e_C$  are measured at the lead tips with the leads unconstrained.  $e_C$  must be zero or greater.
8. B1 maximum dimensions do not include dambar protrusions. Dambar protrusions shall not exceed 0.010 inch (0.25mm).
9. N is the maximum number of terminal positions.
10. Corner leads (1, N, N/2 and N/2 + 1) for E8.3, E16.3, E18.3, E28.3, E42.6 will have a B1 dimension of 0.030 - 0.045 inch (0.76 - 1.14mm).

**E28.6 (JEDEC MS-011-AB ISSUE B)  
28 LEAD DUAL-IN-LINE PLASTIC PACKAGE**

SYMBOL	INCHES		MILLIMETERS		NOTES
	MIN	MAX	MIN	MAX	
A	-	0.250	-	6.35	4
A1	0.015	-	0.39	-	4
A2	0.125	0.195	3.18	4.95	-
B	0.014	0.022	0.356	0.558	-
B1	0.030	0.070	0.77	1.77	8
C	0.008	0.015	0.204	0.381	-
D	1.380	1.565	35.1	39.7	5
D1	0.005	-	0.13	-	5
E	0.600	0.625	15.24	15.87	6
E1	0.485	0.580	12.32	14.73	5
e	0.100 BSC		2.54 BSC		-
$e_A$	0.600 BSC		15.24 BSC		6
$e_B$	-	0.700	-	17.78	7
L	0.115	0.200	2.93	5.08	4
N	28		28		9

Rev. 1 12/00

**Ceramic Dual-In-Line Frit Seal Packages (CERDIP)**

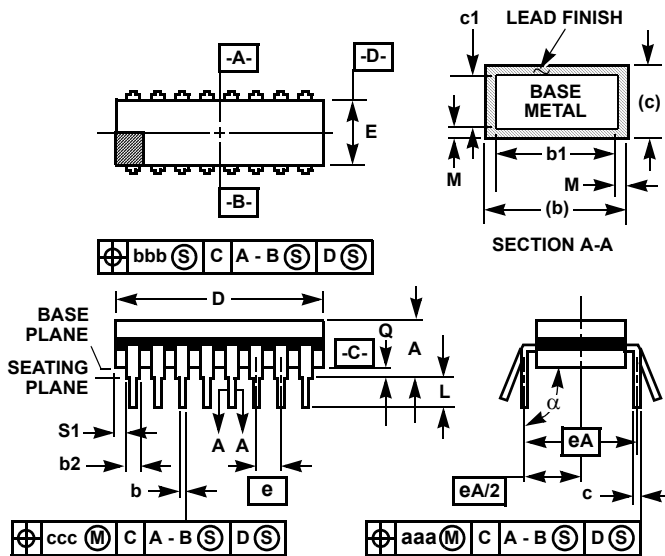

**NOTES:**

1. Index area: A notch or a pin one identification mark shall be located adjacent to pin one and shall be located within the shaded area shown. The manufacturer's identification shall not be used as a pin one identification mark.
2. The maximum limits of lead dimensions b and c or M shall be measured at the centroid of the finished lead surfaces, when solder dip or tin plate lead finish is applied.
3. Dimensions b1 and c1 apply to lead base metal only. Dimension M applies to lead plating and finish thickness.
4. Corner leads (1, N, N/2, and N/2+1) may be configured with a partial lead paddle. For this configuration dimension b3 replaces dimension b2.
5. This dimension allows for off-center lid, meniscus, and glass overrun.
6. Dimension Q shall be measured from the seating plane to the base plane.
7. Measure dimension S1 at all four corners.
8. N is the maximum number of terminal positions.
9. Dimensioning and tolerancing per ANSI Y14.5M - 1982.
10. Controlling dimension: INCH.

**F16.3 MIL-STD-1835 GDIP1-T16 (D-2, CONFIGURATION A)  
16 LEAD CERAMIC DUAL-IN-LINE FRIT SEAL PACKAGE**

SYMBOL	INCHES		MILLIMETERS		NOTES
	MIN	MAX	MIN	MAX	
A	-	0.200	-	5.08	-
b	0.014	0.026	0.36	0.66	2
b1	0.014	0.023	0.36	0.58	3
b2	0.045	0.065	1.14	1.65	-
b3	0.023	0.045	0.58	1.14	4
c	0.008	0.018	0.20	0.46	2
c1	0.008	0.015	0.20	0.38	3
D	-	0.840	-	21.34	5
E	0.220	0.310	5.59	7.87	5
e	0.100 BSC		2.54 BSC		-
eA	0.300 BSC		7.62 BSC		-
eA/2	0.150 BSC		3.81 BSC		-
L	0.125	0.200	3.18	5.08	-
Q	0.015	0.060	0.38	1.52	6
S1	0.005	-	0.13	-	7
$\alpha$	90°	105°	90°	105°	-
aaa	-	0.015	-	0.38	-
bbb	-	0.030	-	0.76	-
ccc	-	0.010	-	0.25	-
M	-	0.0015	-	0.038	2, 3
N	16		16		8

Rev. 0 4/94

**Ceramic Dual-In-Line Frit Seal Packages (CERDIP)**

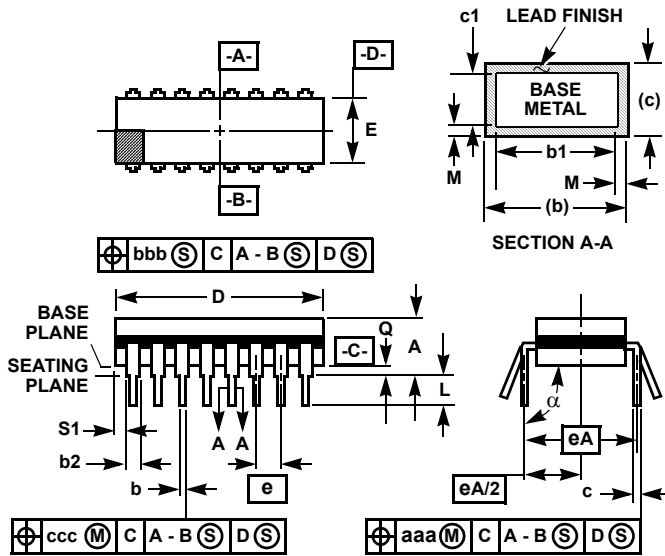

**NOTES:**

1. Index area: A notch or a pin one identification mark shall be located adjacent to pin one and shall be located within the shaded area shown. The manufacturer's identification shall not be used as a pin one identification mark.
2. The maximum limits of lead dimensions b and c or M shall be measured at the centroid of the finished lead surfaces, when solder dip or tin plate lead finish is applied.
3. Dimensions b1 and c1 apply to lead base metal only. Dimension M applies to lead plating and finish thickness.
4. Corner leads (1, N, N/2, and N/2+1) may be configured with a partial lead paddle. For this configuration dimension b3 replaces dimension b2.
5. This dimension allows for off-center lid, meniscus, and glass overrun.
6. Dimension Q shall be measured from the seating plane to the base plane.
7. Measure dimension S1 at all four corners.
8. N is the maximum number of terminal positions.
9. Dimensioning and tolerancing per ANSI Y14.5M - 1982.
10. Controlling dimension: INCH.

**F28.6 MIL-STD-1835 GDIP1-T28 (D-10, CONFIGURATION A)  
28 LEAD CERAMIC DUAL-IN-LINE FRIT SEAL PACKAGE**

SYMBOL	INCHES		MILLIMETERS		NOTES
	MIN	MAX	MIN	MAX	
A	-	0.232	-	5.92	-
b	0.014	0.026	0.36	0.66	2
b1	0.014	0.023	0.36	0.58	3
b2	0.045	0.065	1.14	1.65	-
b3	0.023	0.045	0.58	1.14	4
c	0.008	0.018	0.20	0.46	2
c1	0.008	0.015	0.20	0.38	3
D	-	1.490	-	37.85	5
E	0.500	0.610	12.70	15.49	5
e	0.100 BSC		2.54 BSC		-
eA	0.600 BSC		15.24 BSC		-
eA/2	0.300 BSC		7.62 BSC		-
L	0.125	0.200	3.18	5.08	-
Q	0.015	0.060	0.38	1.52	6
S1	0.005	-	0.13	-	7
$\alpha$	90°	105°	90°	105°	-
aaa	-	0.015	-	0.38	-
bbb	-	0.030	-	0.76	-
ccc	-	0.010	-	0.25	-
M	-	0.0015	-	0.038	2, 3
N	28		28		8

Rev. 0 4/94

**Small Outline Plastic Packages (SOIC)**

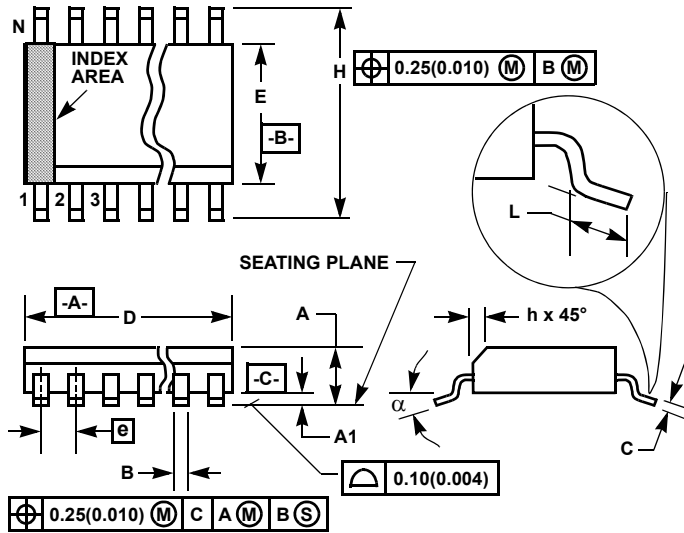

**M16.15 (JEDEC MS-012-AC ISSUE C)**  
**16 LEAD NARROW BODY SMALL OUTLINE PLASTIC PACKAGE**

SYMBOL	INCHES		MILLIMETERS		NOTES
	MIN	MAX	MIN	MAX	
A	0.0532	0.0688	1.35	1.75	-
A1	0.0040	0.0098	0.10	0.25	-
B	0.013	0.020	0.33	0.51	9
C	0.0075	0.0098	0.19	0.25	-
D	0.3859	0.3937	9.80	10.00	3
E	0.1497	0.1574	3.80	4.00	4
e	0.050 BSC		1.27 BSC		-
H	0.2284	0.2440	5.80	6.20	-
h	0.0099	0.0196	0.25	0.50	5
L	0.016	0.050	0.40	1.27	6
N	16		16		7
alpha	0°	8°	0°	8°	-

**NOTES:**

1. Symbols are defined in the "MO Series Symbol List" in Section 2.2 of Publication Number 95.
2. Dimensioning and tolerancing per ANSI Y14.5M-1982.
3. Dimension "D" does not include mold flash, protrusions or gate burrs. Mold flash, protrusion and gate burrs shall not exceed 0.15mm (0.006 inch) per side.
4. Dimension "E" does not include interlead flash or protrusions. Interlead flash and protrusions shall not exceed 0.25mm (0.010 inch) per side.
5. The chamfer on the body is optional. If it is not present, a visual index feature must be located within the crosshatched area.
6. "L" is the length of terminal for soldering to a substrate.
7. "N" is the number of terminal positions.
8. Terminal numbers are shown for reference only.
9. The lead width "B", as measured 0.36mm (0.014 inch) or greater above the seating plane, shall not exceed a maximum value of 0.61mm (0.024 inch).
10. Controlling dimension: MILLIMETER. Converted inch dimensions are not necessarily exact.

Rev. 1 6/05

**Small Outline Plastic Packages (SOIC)**

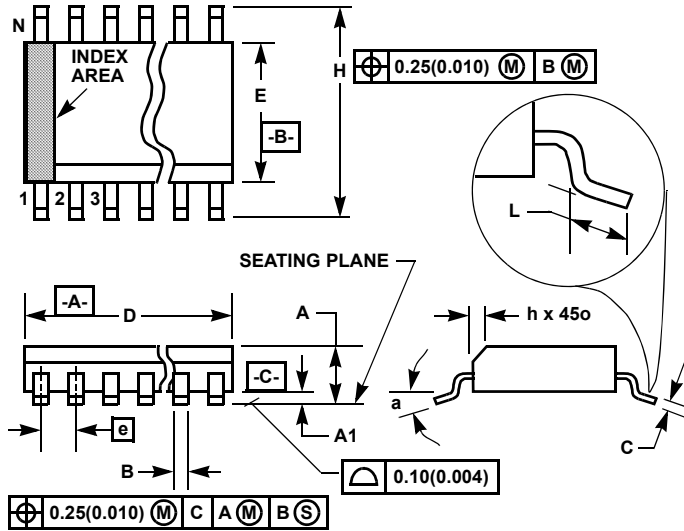

**M28.3 (JEDEC MS-013-AE ISSUE C)  
28 LEAD WIDE BODY SMALL OUTLINE PLASTIC PACKAGE**

SYMBOL	INCHES		MILLIMETERS		NOTES
	MIN	MAX	MIN	MAX	
A	0.0926	0.1043	2.35	2.65	-
A1	0.0040	0.0118	0.10	0.30	-
B	0.013	0.0200	0.33	0.51	9
C	0.0091	0.0125	0.23	0.32	-
D	0.6969	0.7125	17.70	18.10	3
E	0.2914	0.2992	7.40	7.60	4
e	0.05 BSC		1.27 BSC		-
H	0.394	0.419	10.00	10.65	-
h	0.01	0.029	0.25	0.75	5
L	0.016	0.050	0.40	1.27	6
N	28		28		7
$\alpha$	0°	8°	0°	8°	-

Rev. 1, 1/13

NOTES:

1. Symbols are defined in the "MO Series Symbol List" in Section 2.2 of Publication Number 95.
2. Dimensioning and tolerancing per ANSI Y14.5M-1982.
3. Dimension "D" does not include mold flash, protrusions or gate burrs. Mold flash, protrusion and gate burrs shall not exceed 0.15mm (0.006 inch) per side.
4. Dimension "E" does not include interlead flash or protrusions. Interlead flash and protrusions shall not exceed 0.25mm (0.010 inch) per side.
5. The chamfer on the body is optional. If it is not present, a visual index feature must be located within the crosshatched area.
6. "L" is the length of terminal for soldering to a substrate.
7. "N" is the number of terminal positions.
8. Terminal numbers are shown for reference only.
9. The lead width "B", as measured 0.36mm (0.014 inch) or greater above the seating plane, shall not exceed a maximum value of 0.61mm (0.024 inch)
10. Controlling dimension: MILLIMETER. Converted inch dimensions are not necessarily exact.

**TYPICAL RECOMMENDED LAND PATTERN**

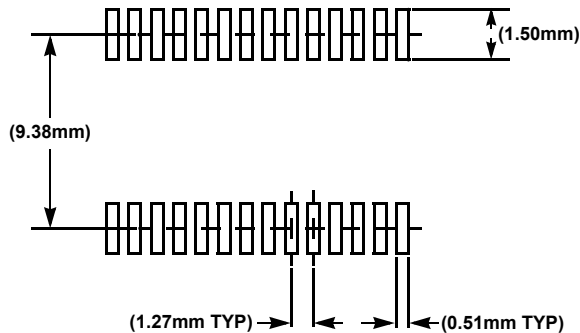

**Plastic Leaded Chip Carrier Packages (PLCC)**

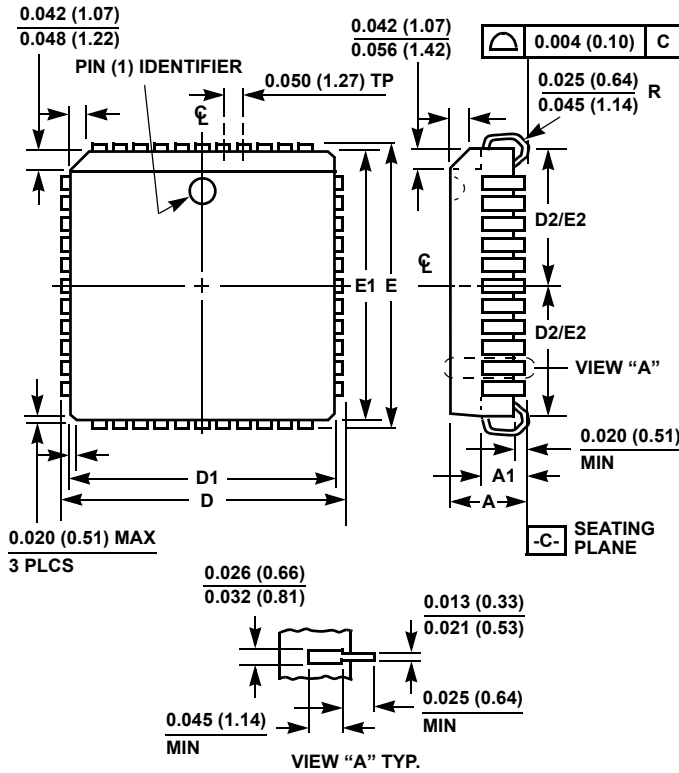

**N20.35 (JEDEC MS-018AA ISSUE A)  
20 LEAD PLASTIC LEADED CHIP CARRIER PACKAGE**

SYMBOL	INCHES		MILLIMETERS		NOTES
	MIN	MAX	MIN	MAX	
A	0.165	0.180	4.20	4.57	-
A1	0.090	0.120	2.29	3.04	-
D	0.385	0.395	9.78	10.03	-
D1	0.350	0.356	8.89	9.04	3
D2	0.141	0.169	3.59	4.29	4, 5
E	0.385	0.395	9.78	10.03	-
E1	0.350	0.356	8.89	9.04	3
E2	0.141	0.169	3.59	4.29	4, 5
N	20		20		6

Rev. 2 11/97

**NOTES:**

- Controlling dimension: INCH. Converted millimeter dimensions are not necessarily exact.
- Dimensions and tolerancing per ANSI Y14.5M-1982.
- Dimensions D1 and E1 do not include mold protrusions. Allowable mold protrusion is 0.010 inch (0.25mm) per side. Dimensions D1 and E1 include mold mismatch and are measured at the extreme material condition at the body parting line.
- To be measured at seating plane [-C-] contact point.
- Centerline to be determined where center leads exit plastic body.
- "N" is the number of terminal positions.



## Looking for pricing, stock, or lifecycle information?

Click below to explore more details on WIN SOURCE:

 [View HI1-0508-5 on WIN SOURCE](#)

 [Intersil Information](#)

## Optimize Your Supply Chain with WIN SOURCE Solutions

-  Global Sourcing Solution
-  Obsolete Management
-  Cost Control Management
-  Shortage Management
-  Alternative Solution
-  Excess Inventory Management