

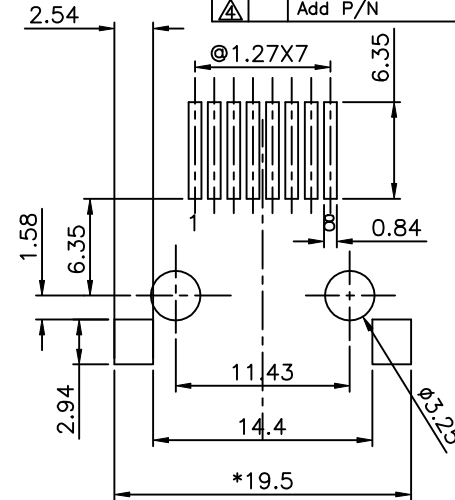

**THE DATASHEET OF
E5388-EJ05V2-L**

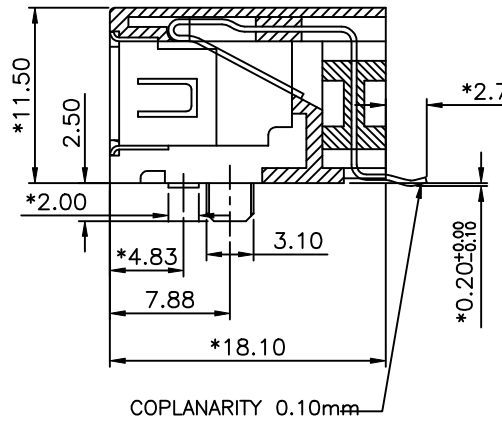

Modify P/N		summy 04/16/05	REVISION RECORD		
REV	ECO	DESCRIPTION	DRFT	CHKD	
△		MODIFY DRAWING	Chan 10/22/02		H
△		MODIFY DRAWING	summy 11/25/03		G
△		MODIFY DRAWING	WJG 03/06/04		F
△		Add P/N	summy 10/23/04		E

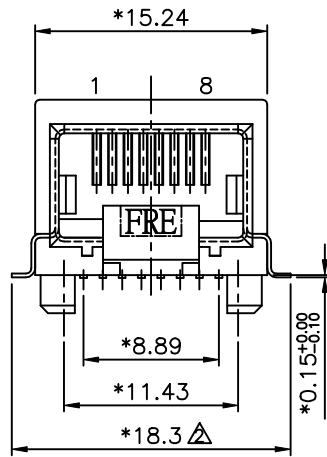

NOTES:

ELECTRICAL:

- VOLTAGE RATING : 125 VAC RMS.
- CURRENT RATING : 1.5 AMP.
- CONTACT RESISTANCE : 35 MILLIOHMS MAX.
- INSULATION RESISTANCE: 1000 MEGOHMS MIN @ 500 VDC.
- DIELECTRIC STRENGTH : 1000 VAC RMS 60Hz, 1MIN.

MECHANICAL:

- HOUSING MATERIAL : FR52
- CONTACT MATERIAL : PHOSPHOR BRONZE t=0.35mm.
- PLATING : 1: CONTACT AREA- SELECTIVE GOLD PLATING.
2: TAILS- 150u" TIN-LEAD MIN OVER 50u" NICKEL.
- OPERATING LIFE : 750 CYCLES MIN.
- PCB RETENTION POST-SOLDER: 10 LBS MIN.

ENVIRONMENTAL:

- STORAGE : -40°C TO +85°C.
- OPERATION: 0°C TO 70°C.

MATES WITH MODULAR PLUG CONFORMING TO FCC PART 68, SUBPART F.

△ PART NUMBER: E5388-EX05VX

9- W/O LOGO
J- W/ FRE LOGO

- 1- 3U"
- 2- 6U"
- 3- 15U"
- 4- 30U"
- 5- 50U"

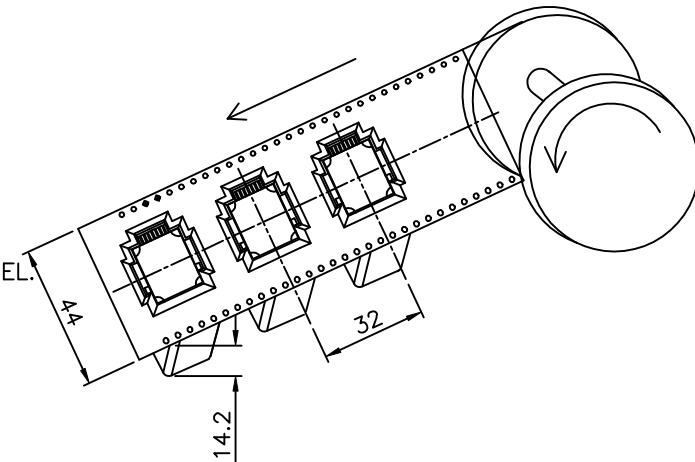

DETACHED LISTS	MM (INCH)	DFTO CZH	DATE 6/1/2002	FULL RISE ELECTRONIC CO., LTD	
	TOLERANCES EXCEPT AS NOTED	CHKDANKUE	DATE 2005/4/20		
	MM	MFO	DATE	TITLE SIDE ENTRY 8P △ INTERNAL SHIELD(SMD)	
	.0 ±0.20 ±	APPVLLUSHENG	DATE 2005/4/20		
.00 ±0.15 ±	MATERIAL :		DRAWING NO. GE533039		
.000 ±0.075 ±	ANGLES ±		/PART NO. SEE NOTE		
THIRD ANGLE PROJECTION	FINISH :		SCALE : 3:1	SIZE A3	REV 5
DO NOT SCALE DRAWING			SHEET X OF Y		

Looking for pricing, stock, or lifecycle information?

Click below to explore more details on WIN SOURCE:

 [View E5388-EJ05V2-L on WIN SOURCE](#)

 [Pulse Information](#)

Optimize Your Supply Chain with WIN SOURCE Solutions

-  Global Sourcing Solution
-  Obsolete Management
-  Cost Control Management
-  Shortage Management
-  Alternative Solution
-  Excess Inventory Management