



**THE DATASHEET OF  
SG-636PTF 25.0000MC3**



**CRYSTAL OSCILLATOR (SPXO)**  
OUTPUT : CMOS, TTL



Product Number (please contact us)  
SG-636 : Q33636xx2xxxx00

**SG-636 series**

- Frequency range : 2.21675 MHz to 41 MHz
- Supply voltage : 2.5 V Typ. / 3.3 V Typ. / 5.0 V Typ.
- Function : Output enable(OE) or Standby( $\overline{ST}$ )
- External dimensions : 10.5 x 5.8 x 2.7 mm (t: Max.)



Actual size

SG-636 series



**Specifications (characteristics)**

Item	Symbol	Specifications			Conditions / Remarks
		SG-636 PTF	SG-636 PCE SG-636 SCE	SG-636 PDE	
Output frequency range	$f_0$	2.21675 MHz to 41.000 MHz	2.21675 MHz to 40.000 MHz	2.21675 MHz to 40.000 MHz	Please contact us about available frequencies.
Supply voltage	V <sub>cc</sub>	5.0 V $\pm$ 0.5 V	3.3 V $\pm$ 0.3 V	2.5 V $\pm$ 0.25 V	
Storage temperature	T <sub>stg</sub>	-55 °C to +100 °C			Storage as single product.
Operating temperature	T <sub>use</sub>	-20 °C to +70 °C			
Frequency tolerance	f <sub>tol</sub>	C: $\pm$ 100 x 10 <sup>-6</sup>			-20 °C to +70 °C
Current consumption	I <sub>cc</sub>	17 mA Max.	9 mA Max.	5 mA Max.	No load condition
Disable current	I <sub>dis</sub>	10 mA Max.	5 mA Max.	3 mA Max.	OE=GND
Stand-by current	I <sub>std</sub>	—	2 $\mu$ A Max.	—	$\overline{ST}$ =GND(SCE)
Symmetry	SYM	40 % to 60 %	45 % to 55 %		CMOS load:50 % V <sub>cc</sub> level
		45 % to 55 %	—		TTL load: 1.4 V level
Output voltage	V <sub>OH</sub>	V <sub>cc</sub> -0.4 V Min.			I <sub>OH</sub> =-8 mA(PTF) / -4 mA(SCE,PCE) / -3.2 mA(PDE)
	V <sub>OL</sub>	0.4 V Max.			I <sub>OL</sub> =16 mA(PTF) / 4 mA(SCE,PCE) / 3.2 mA(PDE)
Output load condition (TTL)	L <sub>TTL</sub>	10 TTL Max.	—		L <sub>CMOS</sub> $\leq$ 15 pF
Output load condition (CMOS)	L <sub>CMOS</sub>	50 pF Max.	30 pF Max.	15 pF Max.	
Input voltage	V <sub>IH</sub>	2.0 V Min.	80 % V <sub>cc</sub> Min.		OE Terminal or $\overline{ST}$ Terminal (SCE)
	V <sub>IL</sub>	0.8 V Max.	20 % V <sub>cc</sub> Max.		
Rise time / Fall time	tr / tf	7 ns Max.	5 ns Max.		CMOS load:20 % V <sub>cc</sub> to 80 % V <sub>cc</sub> level
		5 ns Max.	—		TTL load:0.4 V to 2.4 V level
Start-up time	t <sub>str</sub>	4 ms Max.	4 ms Max.		Time at minimum supply voltage to be 0 s
Frequency aging	f <sub>aging</sub>	$\pm$ 5 x 10 <sup>-6</sup> / year Max.			+25 °C, V <sub>cc</sub> =5.0 V/3.3 V/2.5 V, First year

Product Name SG-636 PTF 18.43200MHz C  
(Standard form) ① ②③ ④ ⑤

- ①Model ②Function (P: Output enable, S:Standby) ③Supply voltage(T : 5.0V Typ. C : 3.3V Typ. D : 2.5V Typ.)  
④Frequency ⑤Frequency tolerance( C :  $\pm$ 100 x 10<sup>-6</sup> / -20 °C ~ +70 °C)

**External dimensions**

(Unit:mm)

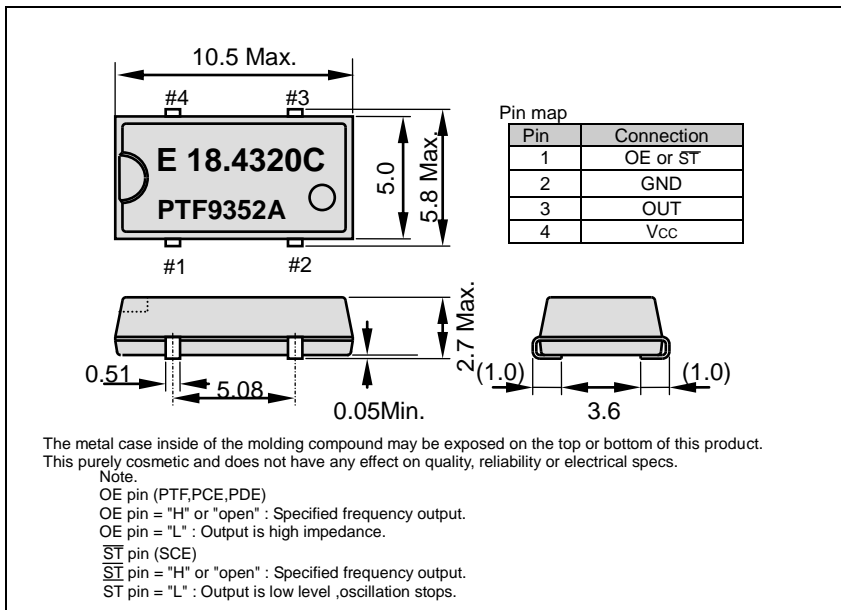

**Footprint (Recommended)**

(Unit:mm)

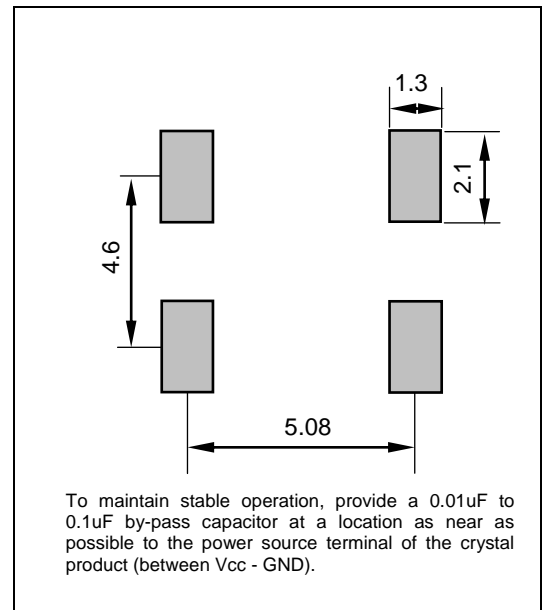

## PROMOTION OF ENVIRONMENTAL MANAGEMENT SYSTEM CONFORMING TO INTERNATIONAL STANDARDS

At Seiko Epson, all environmental initiatives operate under the Plan-Do-Check-Action (PDCA) cycle designed to achieve continuous improvements. The environmental management system (EMS) operates under the ISO 14001 environmental management standard.

All of our major manufacturing and non-manufacturing sites, in Japan and overseas, completed the acquisition of ISO 14001 certification.

ISO 14000 is an international standard for environmental management that was established by the International Standards Organization in 1996 against the background of growing concern regarding global warming, destruction of the ozone layer, and global deforestation.





## WORKING FOR HIGH QUALITY

In order provide high quality and reliable products and services than meet customer needs,

Seiko Epson made early efforts towards obtaining ISO9000 series certification and has acquired ISO9001 for all business establishments in Japan and abroad. We have also acquired ISO/TS 16949 certification that is requested strongly by major automotive manufacturers as standard.

ISO/TS16949 is the international standard that added the sector-specific supplemental requirements for automotive industry based on ISO9001.

### ► Explanation of the mark that are using it for the catalog

	► Pb free.
	► Complies with EU RoHS directive. *About the products without the Pb-free mark. Contains Pb in products exempted by EU RoHS directive. (Contains Pb in sealing glass, high melting temperature type solder or other.)
	► Designed for automotive applications such as Car Multimedia, Body Electronics, Remote Keyless Entry etc.
	► Designed for automotive applications related to driving safety (Engine Control Unit, Air Bag, ESC etc ).

## Notice

- This material is subject to change without notice.
- Any part of this material may not be reproduced or duplicated in any form or any means without the written permission of Seiko Epson.
- The information about applied data, circuitry, software, usage, etc. written in this material is intended for reference only. Seiko Epson does not assume any liability for the occurrence of customer damage or infringing on any patent or copyright of a third party. This material does not authorize the licensing for any patent or intellectual copyrights.
- When exporting the products or technology described in this material, you should comply with the applicable export control laws and regulations and follow the procedures required by such laws and regulations.
- You are requested not to use the products (and any technical information furnished, if any) for the development and/or manufacture of weapon of mass destruction or for other military purposes. You are also requested that you would not make the products available to any third party who may use the products for such prohibited purposes.
- These products are intended for general use in electronic equipment. When using them in specific applications that require extremely high reliability, such as the applications stated below, you must obtain permission from Seiko Epson in advance.  
/ Space equipment (artificial satellites, rockets, etc.) / Transportation vehicles and related (automobiles, aircraft, trains, vessels, etc.) / Medical instruments to sustain life / Submarine transmitters / Power stations and related / Fire work equipment and security equipment / traffic control equipment / and others requiring equivalent reliability.
- All brands or product names mentioned herein are trademarks and/or registered trademarks of their respective.

## Looking for pricing, stock, or lifecycle information?

Click below to explore more details on WIN SOURCE:

- ⊖ [View SG-636PTF 25.0000MC3 on WIN SOURCE](#)
- ⊖ [Seiko Epson Corporation Information](#)

## Optimize Your Supply Chain with WIN SOURCE Solutions

- ✓ Global Sourcing Solution
- ✓ Obsolete Management
- ✓ Cost Control Management
- ✓ Shortage Management
- ✓ Alternative Solution
- ✓ Excess Inventory Management