



**THE DATASHEET OF
HT7533-1**



Product introduction

75xx series is a low-power high-voltage regulator manufactured by CMOS process. The maximum input voltage is 30V and the output voltage range is 1.5V~12.0V. It has the characteristics of high precision output voltage, very low power supply current and very low drop voltage.

Product features

- Low power consumption: $\leq 3 \mu A$
- Low drop voltage: typical value 0.1V
- Low temperature bleaching: typical 50 ppm / °C
- High input voltage: up to 30V
- High precision output voltage: tolerance of + 3%
- Package form: TO-92, SOT89-3, SOT-23-3, SOT23-5

Product use

- Battery power supply equipment
- Various communication equipment
- Audio / video equipment
- Security monitoring equipment

Package form and pin function definition

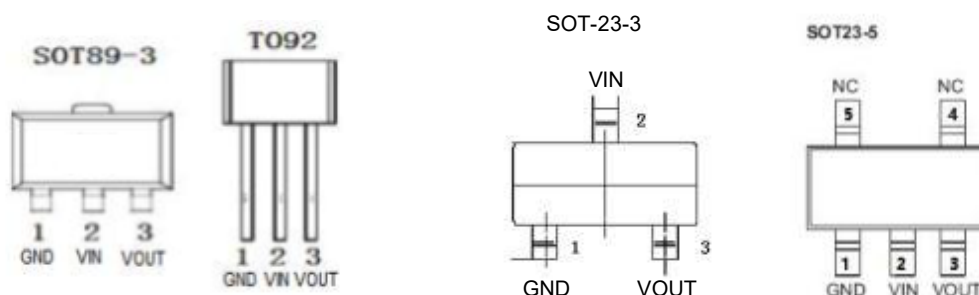

Model selection

| name | Order Code | Maximum input voltage (V) | Output voltage (V) | tolerance | Package |
|------|------------|---------------------------|--------------------|-----------|---|
| 75XX | 7530 | 30 | 3.0 | ±3% | TO92 SOT89-3 SOT-23-3 SOT-23-5 |
| | 7533 | 30 | 3.3 | ±3% | |
| | 7536 | 30 | 3.6 | ±3% | |
| | 7544 | 30 | 4.4 | ±3% | |
| | 7550 | 30 | 5.0 | ±3% | |

■ Principle block diagram

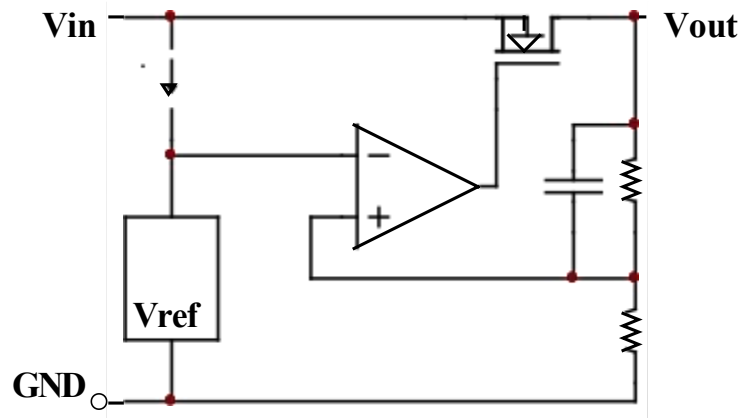

Limit parameter

| project | Symbol | parameter | | Limit value | Company |
|-------------|--------|-----------------------|----------|-------------|---------|
| Voltage | VIN | Maximum input voltage | | 30 | V |
| power waste | PD | power waste | T0-92 | 700 | mW |
| | | | SOT-23 | 300 | |
| | | | SOT-89 | 400 | |
| | | | SOT-23-5 | 300 | |
| temperature | Tw | working temperature | | -40~85 | °C |
| | Tc | Storage temperature | | -50~125 | °C |
| | Th | welding temperature | | 260 | °C, 10s |

Electrical properties

7530 (T_{OPT}=25°C)

| Symbol | parameter | Test conditions | minimum value | Typical value | Maximum | Company |
|--|-------------------------|--|---------------|---------------|---------|---------|
| V _{OUT} | output voltage | V _{IN} =5V, I _{OUT} =10mA | 2.91 | 3 | 3.09 | V |
| I _{OUT} | Output current | V _{IN} =5V | 60 | 100 | | mA |
| ΔV _{OUT} | Load regulation | V _{IN} =5V, 1mA ≤ I _{OUT} ≤ 20mA | — | 100 | 150 | mV |
| V _{DIF} | Drop voltage | I _{OUT} =1mA | — | 100 | — | mV |
| I _{SS} | Quiescent current | Vin = 5V, no load | — | 2 | 3 | μA |
| ΔV _{OUT} / (ΔV _{IN} * V _{OUT}) | Line Regulation | 4V ≤ V _{IN} ≤ 30V, I _{OUT} =1mA | — | 0.2 | — | %/V |
| V _{IN} | input voltage | — | — | — | 30 | V |
| ΔV _{OUT} / ΔTa | temperature coefficient | V _{IN} =5V, I _{OUT} =10mA 0°C ≤ Ta ≤ 70°C | — | ±0.45 | — | mV/°C |

7533 (T_{OPT}=25°C)

| Symbol | parameter | Test conditions | minimum value | Typical value | Maximum | Company |
|--|-------------------------|---|---------------|---------------|---------|---------|
| V _{OUT} | output voltage | V _{IN} =5.5V, I _{OUT} =10mA | 3.201 | 3.3 | 3.399 | V |
| I _{OUT} | Output current | V _{IN} =5.5V | 60 | 100 | — | mA |
| ΔV _{OUT} | Load regulation | V _{IN} =5.5V, 1mA≤I _{OUT} ≤30mA | — | 100 | 150 | mV |
| V _{DIF} | Drop voltage | I _{OUT} =1mA | — | 100 | — | mV |
| I _{SS} | Quiescent current | V _{IN} = 5.5V, no load | — | 2 | 3 | μA |
| ΔV _{OUT} /(ΔV _{IN} *V _{OUT}) | Line Regulation | 4.5V≤V _{IN} ≤30V, I _{OUT} =1mA | — | 0.2 | — | %/V |
| V _{IN} | input voltage | — | — | — | 30 | V |
| ΔV _{OUT} / ΔTa | temperature coefficient | V _{IN} =5.5V, I _{OUT} =10mA, 0°C≤Ta≤70°C | — | ±0.5 | — | mV/°C |

7536 (T_{OPT}=25°C)

| Symbol | parameter | Test conditions | minimum value | Typical value | Maximum | Company |
|--|-------------------------|---|---------------|---------------|---------|---------|
| V _{OUT} | output voltage | V _{IN} =5.6V, I _{OUT} =10mA | 3.492 | 3.6 | 3.708 | V |
| I _{OUT} | Output current | V _{IN} =5.6V | 60 | 100 | — | mA |
| ΔV _{OUT} | Load regulation | V _{IN} =5.6V, 1mA≤I _{OUT} ≤30mA | — | 100 | 150 | mV |
| V _{DIF} | Drop voltage | I _{OUT} =1mA | — | 100 | — | mV |
| I _{SS} | Quiescent current | V _{IN} = 5.6v, no load | — | 2 | 3 | μA |
| ΔV _{OUT} /(ΔV _{IN} *V _{OUT}) | Line Regulation | 4.6V≤V _{IN} ≤30V, I _{OUT} =1mA | — | 0.2 | — | %/V |
| V _{IN} | input voltage | — | — | — | 30 | V |
| ΔV _{OUT} / ΔTa | temperature coefficient | V _{IN} =5.6V, I _{OUT} =10mA, 0°C≤Ta≤70°C | — | ±0.6 | — | mV/°C |

7544 (T_{OPT}=25°C)

| Symbol | parameter | Test conditions | minimum value | Typical value | Maximum | Company |
|--|-------------------------|---|---------------|---------------|---------|---------|
| V _{OUT} | output voltage | V _{IN} =6.4V, I _{OUT} =10mA | 4.268 | 4.4 | 4.532 | V |
| I _{OUT} | Output current | V _{IN} =6.4V | 60 | 100 | — | mA |
| ΔV _{OUT} | Load regulation | V _{IN} =6.4V, 1mA≤I _{OUT} ≤30mA | — | 100 | 150 | mV |
| V _{DIF} | Drop voltage | I _{OUT} =1mA | — | 100 | — | mV |
| I _{SS} | Quiescent current | V _{IN} = 6.4v, no load | — | 2 | 3 | μA |
| ΔV _{OUT} /(ΔV _{IN} *V _{OUT}) | Line Regulation | 5.4V≤V _{IN} ≤30V, I _{OUT} =1mA | — | 0.2 | — | %/V |
| V _{IN} | input voltage | — | — | — | 30 | V |
| ΔV _{OUT} / ΔTa | temperature coefficient | V _{IN} =6.4V, I _{OUT} =10mA, 0°C≤Ta≤70°C | — | ±0.7 | — | mV/°C |

7550 (T_{OPT}=25°C)

| Symbol | parameter | Test conditions | minimum value | Typical value | Maximum | Company |
|--|-------------------------|---|---------------|---------------|---------|---------|
| V _{OUT} | output voltage | V _{IN} = 7V, I _{OUT} = 10mA | 4.85 | 5 | 5.15 | V |
| I _{OUT} | Output current | V _{IN} = 7V | 60 | 100 | — | mA |
| ΔV _{OUT} | Load regulation | V _{IN} = 7V, 1mA ≤ I _{OUT} ≤ 30mA | — | 100 | | mV |
| V _{DIF} | Drop voltage | I _{OUT} = 1mA | — | 100 | — | mV |
| I _{SS} | Quiescent current | V _{in} = 7V, no load | — | 2 | 3 | μA |
| ΔV _{OUT} / (ΔV _{IN} * V _{OUT}) | Line Regulation | 6V ≤ V _{IN} ≤ 30V, I _{OUT} = 1mA | — | 0.2 | — | %/V |
| V _{IN} | input voltage | — | — | — | 30 | V |
| ΔV _{OUT} / ΔTa | temperature coefficient | V _{IN} = 7V, I _{OUT} = 10mA, 0°C ≤ Ta ≤ 70°C | — | ±0.75 | — | mV/°C |

Application circuit

1. Basic circuit

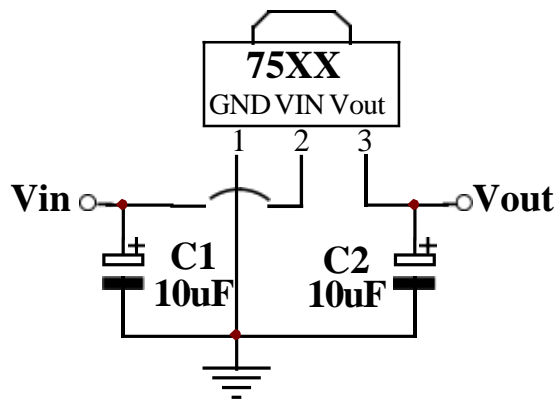

2. High output current regulator

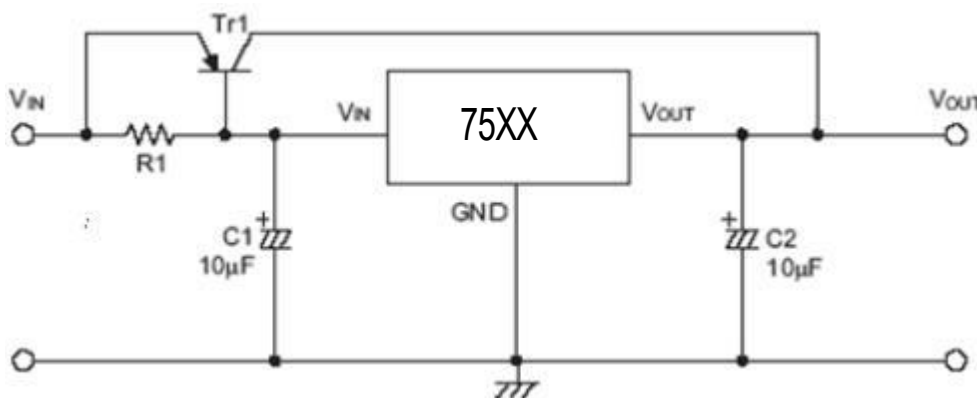

3. Short circuit protection circuit

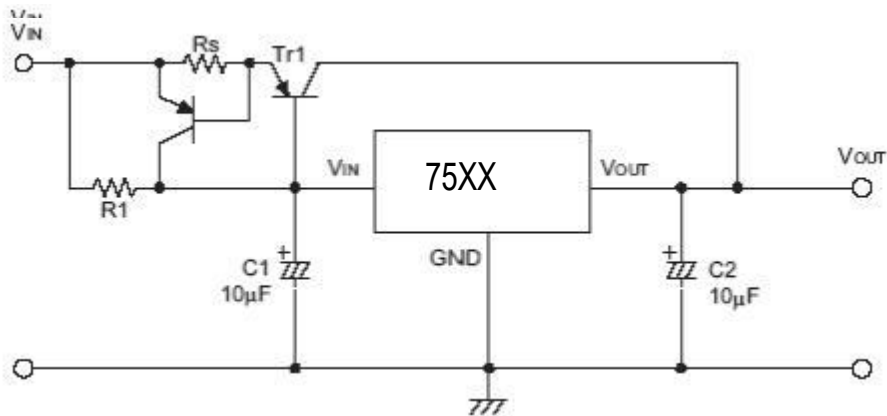

4. Circuit for increasing output voltage (1)

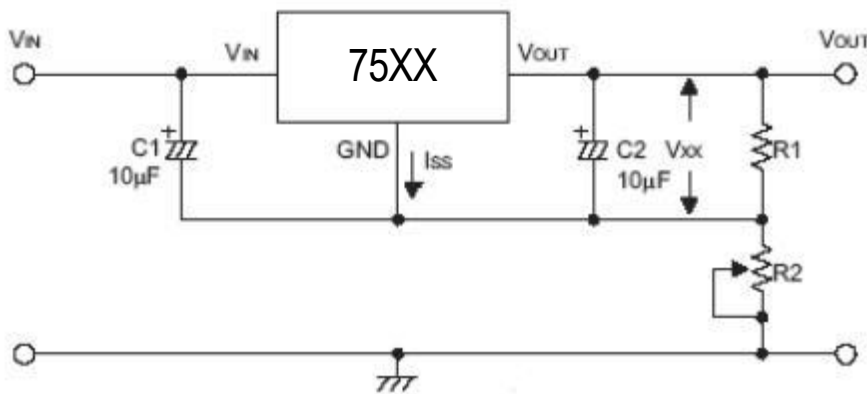

$$V_{OUT} = V_{XX} (1 + R2/R1) + I_{SS} * R2$$

5. Circuit for increasing output voltage (2)

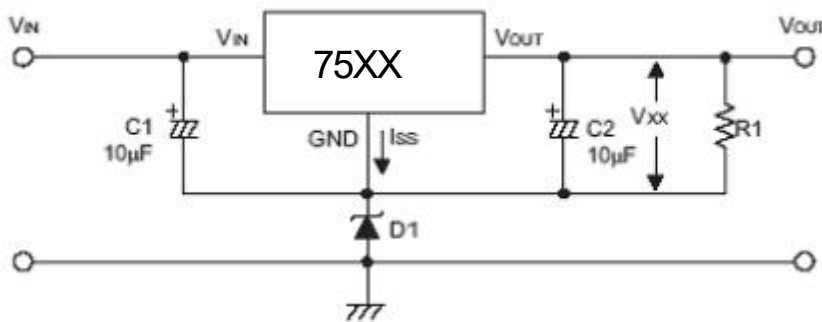

$$V_{OUT} = V_{XX} + VD1$$

6. Current regulating circuit

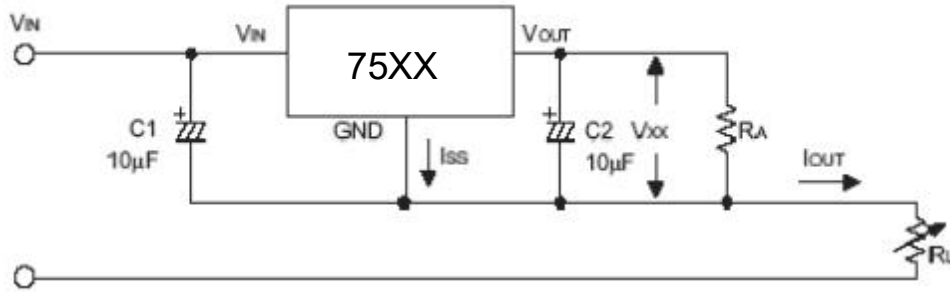

$$I_{OUT} = V_{XX}/R_X + I_{SS}$$

7. Dual output circuit

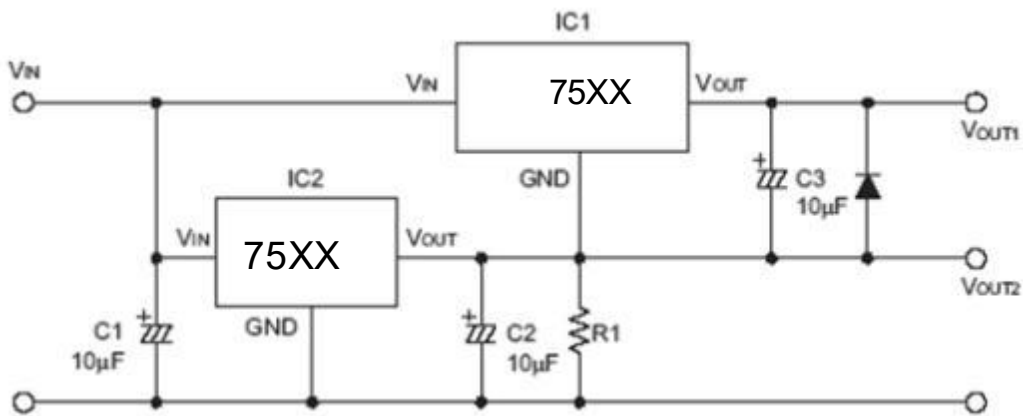

Note: “××” Represents the output voltage

■ Encapsulation information

T0-92

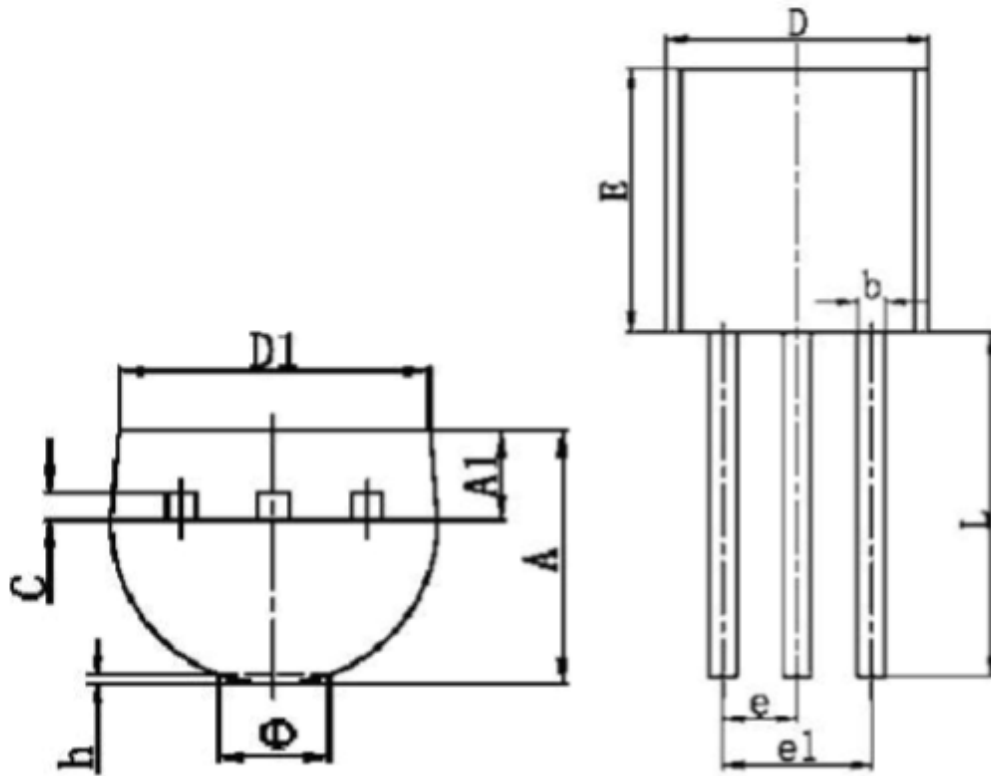

| Symbol | minimum(mm) | Maximum(mm) |
|--------|--------------|--------------|
| A | 3.300 | 3.700 |
| A1 | 1.100 | 1.400 |
| b | 0.380 | 0.550 |
| c | 0.360 | 0.510 |
| D | 4.400 | 4.700 |
| D1 | 3.430 | |
| E | 4.300 | 4.700 |
| e | 1.270 TYP | |
| e1 | 2.440 | 2.640 |
| L | 14.100 | 14.500 |
| Φ | | 1.600 |
| h | 0.000 | 0.380 |

SOT-89-3

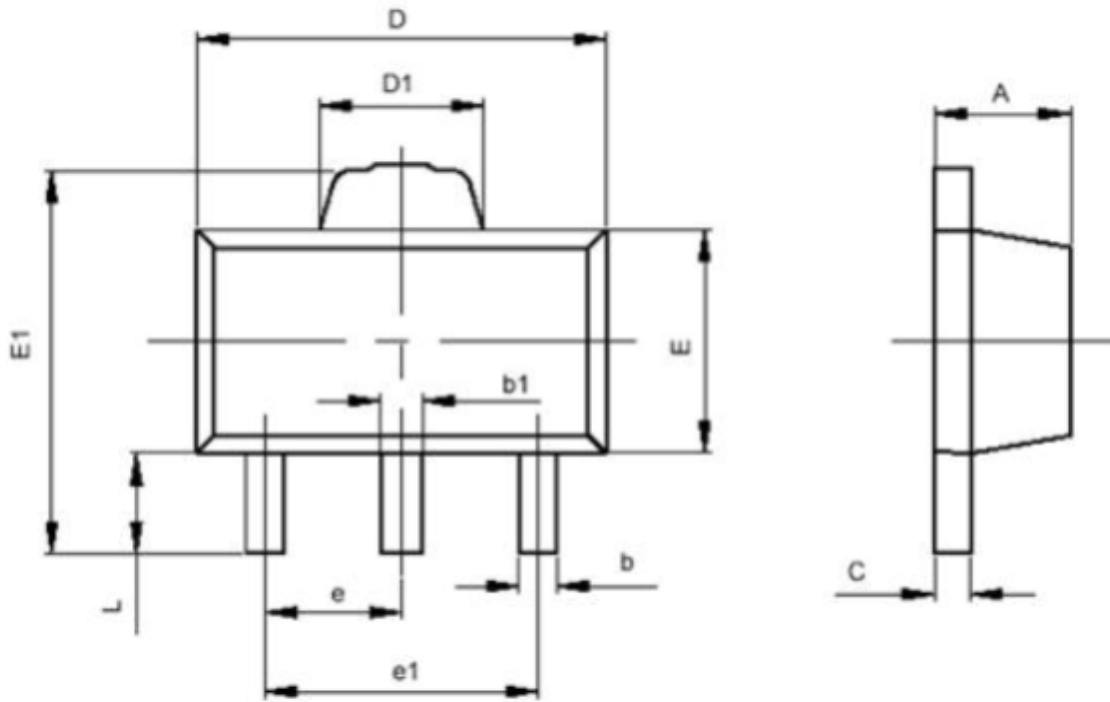

| Symbol | minimum(mm) | Maximum (mm) |
|--------|---------------|----------------|
| A | 1.400 | 1.600 |
| b | 0.320 | 0.520 |
| b1 | 0.360 | 0.560 |
| c | 0.350 | 0.440 |
| D | 4.400 | 4.600 |
| D1 | 1.400 | 1.800 |
| E | 2.300 | 2.600 |
| E1 | 3.940 | 4.250 |
| e | 1.500TYP | |
| e1 | 2.900 | 3.100 |
| L | 0.900 | 1.100 |

SOT-23-3

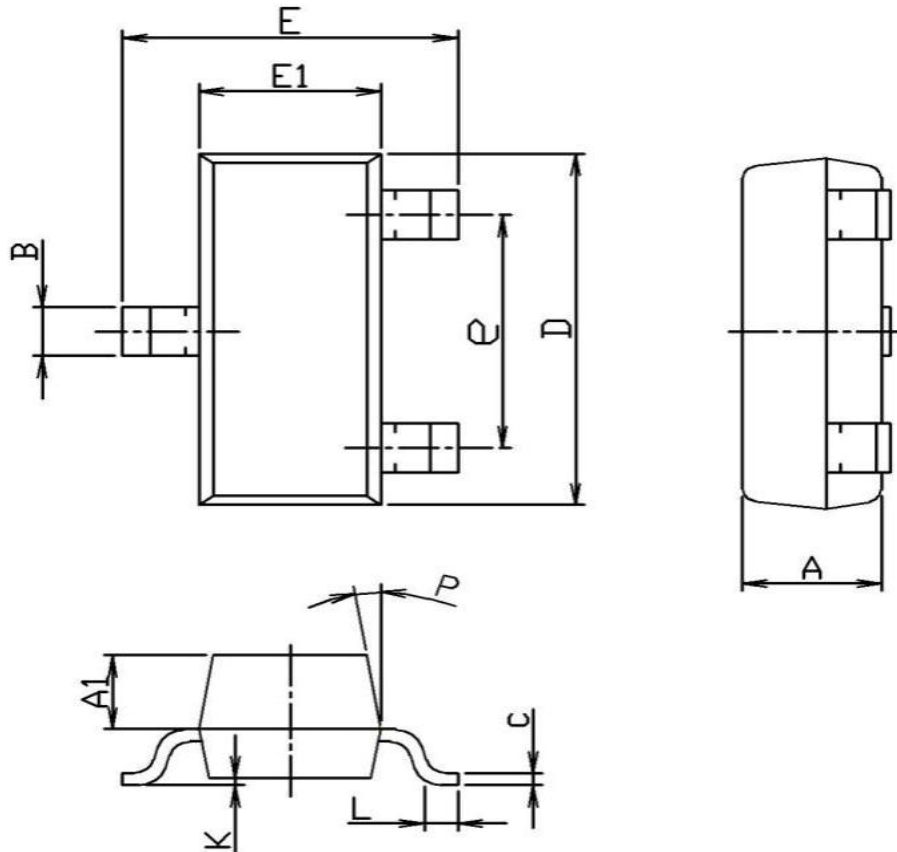

| SOT-23-3 | | Unit: mm | |
|----------|------|----------|------|
| Symbol | Min | TYP | Max |
| A | 0.90 | 1.00 | 1.20 |
| A1 | 0.55 | 0.60 | 0.70 |
| B | 0.35 | 0.40 | 0.55 |
| C | 0.06 | 0.10 | 0.15 |
| D | 2.70 | 2.90 | 3.10 |
| E | 2.20 | 2.40 | 2.60 |
| E1 | 1.20 | 1.30 | 1.50 |
| e | 1.80 | 1.90 | 2.00 |
| K | 0 | 0.08 | 0.18 |
| L | 0.25 | | |
| p | 5° | 7° | 9° |

Looking for pricing, stock, or lifecycle information?

Click below to explore more details on WIN SOURCE:

- [View HT7533-1 on WIN SOURCE](#)
- [NXP / Nexperia Information](#)

Optimize Your Supply Chain with WIN SOURCE Solutions

- ✓ Global Sourcing Solution
- ✓ Obsolete Management
- ✓ Cost Control Management
- ✓ Shortage Management
- ✓ Alternative Solution
- ✓ Excess Inventory Management