



**THE DATASHEET OF
ICS671M-01**



ZERO DELAY LOW SKEW BUFFER AND MULTIPLIER
ICS671-01
Description

The ICS671-01 is a low phase noise, high speed PLL based, 8 output, low skew zero delay buffer and multiplier. Based on IDT's proprietary low jitter Phase Locked Loop (PLL) techniques, the device provides eight low skew outputs at speeds up to 160 MHz at 3.3V. The part includes a bank of six outputs running at either x2 or x4 mode, one output running at either x2, x4, or x4 mode, and one additional output running at either x1, x2, or x4 mode. For normal operation as a zero delay buffer, any output clock is tied to the FBIN pin.

IDT manufactures the largest variety of clock generators and buffers and is the largest clock supplier in the world.

Features

- Packaged in 16 pin SOIC
- Available in Pb (lead) free package
- Clock outputs from 5 to 160 MHz
- Zero input-output delay
- Integrated x2 or x4 selections, and x5 for CLK7
- Eight low-skew (<250 ps) outputs
- Full CMOS outputs with 25 mA output drive capability at TTL levels
- Tri-state mode for board-level testing
- Advanced, low power, sub-micron CMOS process
- Operating voltage of 3.3V or 5V

NOTE: EOL for non-green parts to occur on 5/13/10 per PDN U-09-01

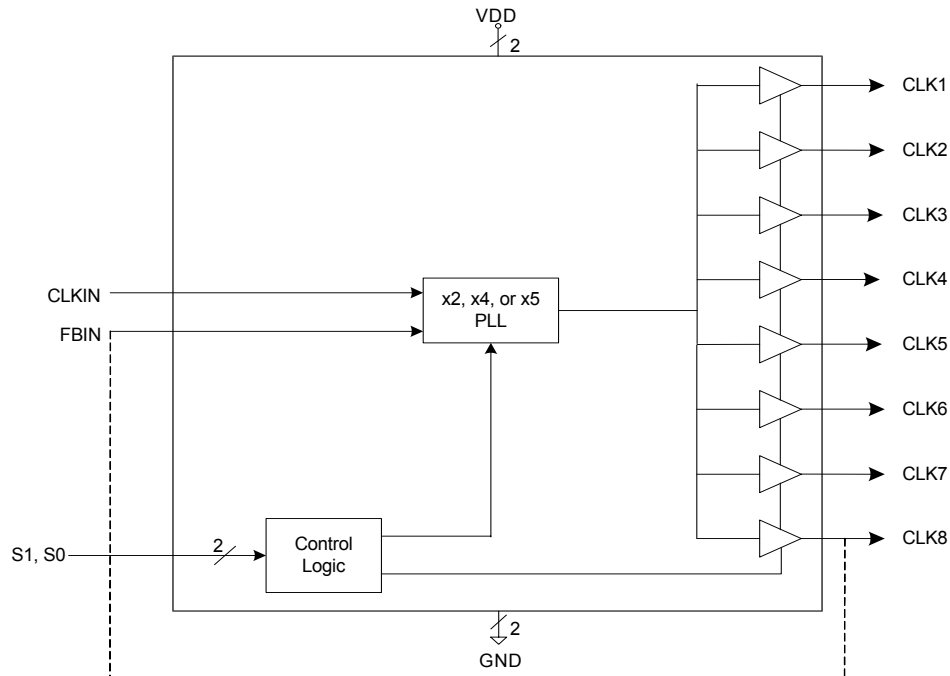
Block Diagram

Pin Assignment

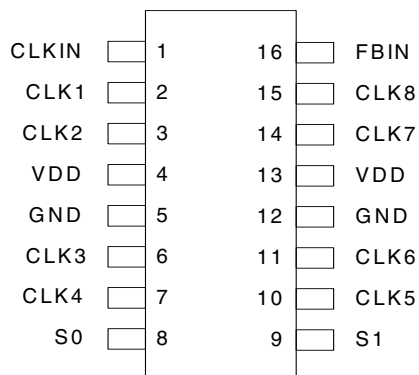

16 pin narrow (150 mil) SOIC

Output Clock Mode Select Table

S1	S0	CLK1:6	CLK7	CLK8	Input Range
0	0	Tri-state (note 1)	Tri-state (note 1)	Tri-state (note 1)	-
0	1	x2 (note 2)	x5 (note 2)	x1	5 to 30 MHz
1	0	x2	x2	x2	15 to 80 MHz
1	1	x4	x4	x4	7.5 to 40 MHz

Note 1. Outputs are in high impedance state

Note 2: In S1:S0 = 01 Mode, only the x1 output on CLK 8 will be zero delay. The x2 and x5 outputs can power-up in different states so the skew relationship is not defined.

Pin Descriptions

Pin Number	Pin Name	Pin Type	Pin Description
1	CLKIN	Input	Clock input.
2-3, 6-7, 10-11	CLK1:6	Output	Clock outputs 1:6. See table above.
4	VDD	Power	Power supply. Connect both pins to the same voltage (either 3.3V or 5V).
5	GND	Power	Connect to ground.
8	S0	Input	Select input 0. See table above.
9	S1	Input	Select input 1. See table above.
12	GND	Power	Connect to ground.
13	VDD	Power	Power supply. Connect both pins to the same voltage (either 3.3V or 5V).
14	CLK7	Output	Clock output 7. See table above.
15	CLK8	Output	Clock output 8. See table above. Normally use this clock as feedback.
16	FBIN	Input	Feedback input. Connect to CLK8 under normal operations.

External Components

The ICS671-01 requires a minimum number of external components for proper operation. Decoupling capacitors of 0.01mF should be connected between VDD and GND on pins 4 and 5, and VDD and GND on pins 13 and 12, as close to the device as possible. A series termination resistor of 33Ω may be used to each clock output pin to reduce reflections.

Absolute Maximum Ratings

Stresses above the ratings listed below can cause permanent damage to the ICS671-01. These ratings, which are standard values for IDT commercially rated parts, are stress ratings only. Functional operation of the device at these or any other conditions above those indicated in the operational sections of the specifications is not implied. Exposure to absolute maximum rating conditions for extended periods can affect product reliability. Electrical parameters are guaranteed only over the recommended operating temperature range.

Item	Rating
Supply Voltage, VDD	7V
All Inputs and Outputs	-0.5V to VDD+0.5V
CLKIN and FBIN inputs	-0.5V to 5.5V
Electrostatic Discharge	2000 V
Ambient Operating Temperature	0 to +70° C
Storage Temperature	-65 to +150° C
Junction Temperature	150° C
Soldering Temperature	260° C

Recommended Operation Conditions

Parameter	Min.	Typ.	Max.	Units
Ambient Operating Temperature	0		+70	°C
Power Supply Voltage (measured in respect to GND)	+3.13		+5.50	V

DC Electrical Characteristics

VDD=3.3V ±10%, Ambient temperature 0 to +70° C, unless stated otherwise

Parameter	Symbol	Conditions	Min.	Typ.	Max.	Units
Operating Voltage	VDD		3.13		5.5	V
Input High Voltage	V _{IH}	CLKIN	VDD/2+1	VDD/2		V
Input Low Voltage	V _{IL}	CLKIN		VDD/2	VDD/2-1	V
Input High Voltage	V _{IH}		2			V
Input Low Voltage	V _{IL}				0.8	V
Input Low Current	I _{IL}	V _{IN} = 0V			50	μA
Input High Current	I _{IH}	V _{IN} = VDD			100	μA
Output High Voltage	V _{OH}	I _{OH} = -25 mA	2.4			V

Parameter	Symbol	Conditions	Min.	Typ.	Max.	Units
Output Low Voltage	V_{OL}	$I_{OL} = 25\text{mA}$			0.4	V
Output High Voltage, CMOS level	V_{OH}	$I_{OH} = -8\text{mA}$	VDD-0.4			V
Operating Supply Current	IDD	No Load, S1 = 1, S0 = 0, Note 1		25		mA
		No Load, S1 = 1, S0 = 0 Note 2				
Power Down Supply Current	IDDPD	CLKIN = 0, S0 = 0, S1 = 0		500		μA
Short Circuit Current	I_{OS}	Each output		± 50		mA
Input Capacitance	C_{IN}	S0, S1, FBIN		7		pF

AC Electrical Characteristics

VDD = 3.3V $\pm 10\%$, Ambient Temperature 0 to +70°C, C_{LOAD} at CLK = 15 pF, unless stated otherwise

Parameter	Symbol	Conditions	Min.	Typ.	Max.	Units
Input Clock Frequency	f_{IN}	See table on page 2	5		80	MHz
Output Clock Frequency		See table on page 2	5		160	MHz
Output Rise Time	t_{OR}	0.8 to 2.0V, CL=30 pF			1.5	ns
Output Fall Time	t_{OF}	2.0 to 0.8V, CL=30 pF			1.5	ns
Output Clock Duty Cycle	t_{DC}	measured at VDD/2	40	50	60	%
Device to Device Skew		rising edges at VDD/2, Note 3			700	ps
Output to Output Skew		rising edges at VDD/2, Note 3			250	ps
Input to Output Skew		rising edges at VDD/2, FBIN to CLK8			± 350	ps
Maximum Absolute Jitter		15 pF		300		ps
Cycle to Cycle Jitter		30 pF loads			500	ps
PLL Lock Time		Note 3			1.0	ms

Note 1: With CLKIN = 20 MHz, FBIN to CLK8, all outputs at 40 MHz.

Note 2: With CLKIN = 80 MHz, FBIN to CLK8, all outputs at 160 MHz.

Note 3: These specs do not apply to mode 01.

Thermal Characteristics (16 pin SOIC)

Parameter	Symbol	Conditions	Min.	Typ.	Max.	Units
Thermal Resistance Junction to Ambient	θ_{JA}	Still air		120		$^{\circ}\text{C/W}$
	θ_{JA}	1 m/s air flow		115		$^{\circ}\text{C/W}$
	θ_{JA}	3 m/s air flow		105		$^{\circ}\text{C/W}$
Thermal Resistance Junction to Case	θ_{JC}			58		$^{\circ}\text{C/W}$

Package Outline and Package Dimensions (16 pin SOIC, 150 Mil. Narrow Body)

Package dimensions are kept current with JEDEC Publication No. 95

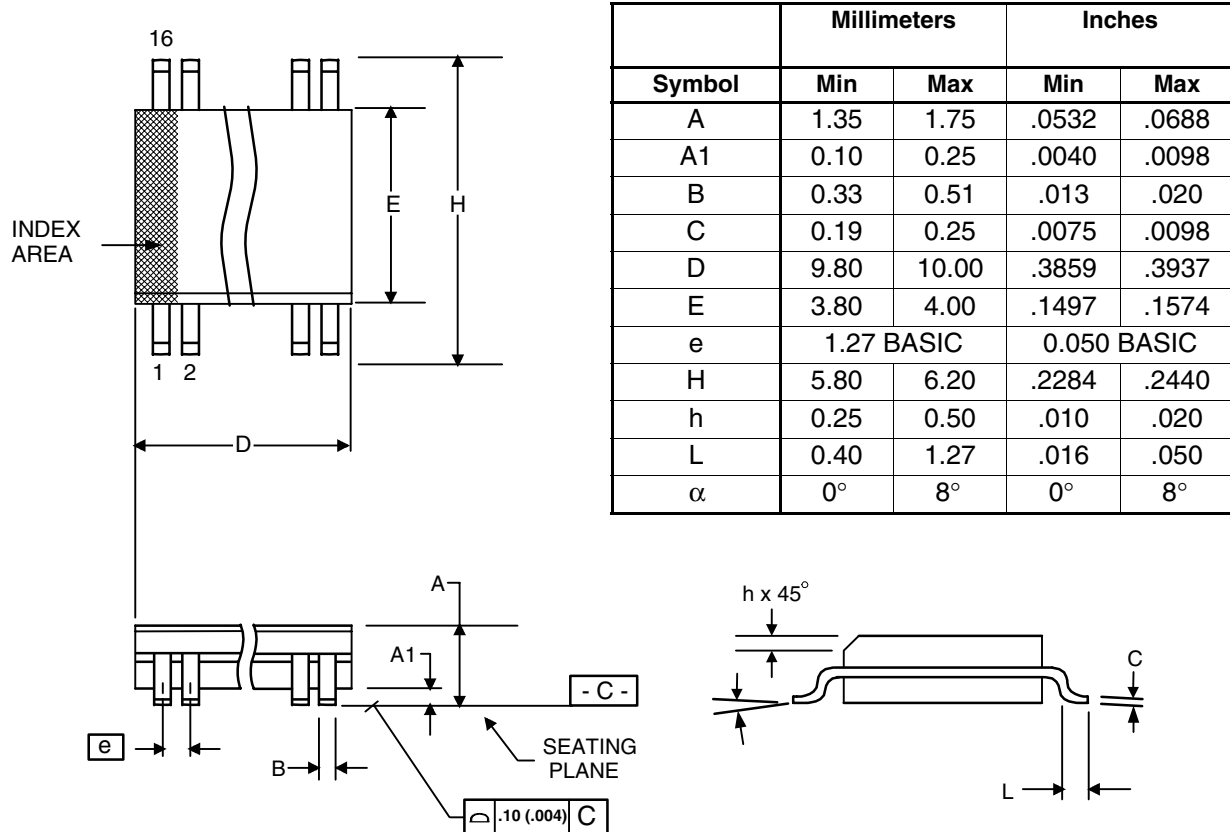

Ordering Information

Part / Order Number	Marking	Shipping Packaging	Package	Temperature
671M-01*	ICS671M-01	Tubes	16-pin SOIC	0 to +70° C
671M-01T*	ICS671M-01	Tape and Reel	16-pin SOIC	0 to +70° C
671M-01LF	ICS671M-01LF	Tubes	16-pin SOIC	0 to +70° C
671M-01LFT	ICS671M-01LF	Tape and Reel	16-pin SOIC	0 to +70° C

*NOTE: EOL for non-green parts to occur on 5/13/10 per PDN U-09-01

Parts that are ordered with a "LF" suffix to the part number are the Pb-Free configuration and are RoHS compliant.

While the information presented herein has been checked for both accuracy and reliability, Integrated Device Technology (IDT) assumes no responsibility for either its use or for the infringement of any patents or other rights of third parties, which would result from its use. No other circuits, patents, or licenses are implied. This product is intended for use in normal commercial applications. Any other applications such as those requiring extended temperature range, high reliability, or other extraordinary environmental requirements are not recommended without additional processing by IDT. IDT reserves the right to change any circuitry or specifications without notice. IDT does not authorize or warrant any IDT product for use in life support devices or critical medical instruments.

Innovate with IDT and accelerate your future networks. Contact:

www.IDT.com

For Sales

800-345-7015
408-284-8200
Fax: 408-284-2775

For Tech Support

www.idt.com/go/clockhelp

Corporate Headquarters

Integrated Device Technology, Inc.
www.idt.com



www.IDT.com

Looking for pricing, stock, or lifecycle information?

Click below to explore more details on WIN SOURCE:

-  [View ICS671M-01 on WIN SOURCE](#)
-  [IDT, Integrated Device Technology Inc Information](#)

Optimize Your Supply Chain with WIN SOURCE Solutions

-  Global Sourcing Solution
-  Obsolete Management
-  Cost Control Management
-  Shortage Management
-  Alternative Solution
-  Excess Inventory Management