IdealBridge Dual MOSFET-Based Bridge Rectifier

Introduction

PD70224 is a dual pack of MOSFET-based full-bridge rectifiers. It contains low-RDS 0.16Ω N-channel MOSFETs for much higher overall efficiency and higher output power, particularly when used in Powered Devices for Power over Ethernet (PoE) applications. The entire drive circuitry for driving the MOSFETs is on-chip, including a charge pump for driving the high-side N-channel MOSFETs. The total forward drop (bridge offset) introduced by the IdealBridge™ rectifier is only 192 mV at 0.6A, compared to a standard bridge rectifier that typically presents 2000 mV of forward drop.

PD70224 IdealBridge™ can support over 2A current, making it the ideal choice for IEEE® 802.3bt (Type 3 and Type 4), IEEE 802.3at and IEEE 802.3af (Type 1 and Type 2). The PD70224 also supports legacy 4 pair standards such as UPoE (60W) and POH (Power over HDBase-T, 95W).

In addition, PD70224 is capable of helping to identify at the physical layer itself whether a 2-pair PSE or a 4-pair PSE is providing power over the cable. It does that by sensing the voltage on the line (un-rectified) side of the pairs.

Features

- Active circuit with low forward-drop to replace dissipative passive diode bridges
- Self-contained drive circuitry for MOSFETs
- Designed to support IEEE 802.3af/at/bt, Universal PoE (UPOE), and Power over HDBase-T (PoH)
- Integrated 0.16Ω N-Channel MOSFETs for 0.32Ω total path resistance
- “Power present” indicator signals for identifying 4-pair bridge power
- Dedicated pin to implement adapter priority
- Low leakage, <10 μA during detection
- Wide operating voltage range up to 57V
- –40°C to 85°C ambient
- Available in 40-pin package
- MSL3, RoHS compliant

The following table lists the Microchip PD products offerings.

Table 1. Microchip Powered Device Products Offerings

Part	Type	Package	IEEE 802.3af	IEEE 802.3at	HDBaseT (PoH)	UPoE
PD70100	Front end	3 mm × 4 mm 12L DFN	x	—	—	—
PD70101	Front end + PWM	5 mm × 5 mm 32L QFN	x	—	—	—
PD70200	Front end	3 mm × 4 mm 12L DFN	x	x	—	—
PD70201	Front end + PWM	5 mm × 5 mm 32L QFN	x	x	—	—
PD70210	Front end	4 mm × 5 mm 16L DFN	x	x	x	x
PD70210A	Front end	4 mm × 5 mm 16L DFN	x	x	x	x
PD70210AL	Front end	5 mm × 7 mm 38L QFN	x	x	x	x
PD70211	Front end + PWM	6 mm × 6 mm 36L QFN	x	x	x	x
PD70224	Ideal diode bridge	6 mm × 8 mm 40L QFN	x	x	x	x

Applications

- Power over Ethernet IEEE 802.3bt/at/af
- Proprietary 4-pair standards, UPoE, and PoH

Figure 1. Dual Conventional Bridge Versus Single Ideal Bridge

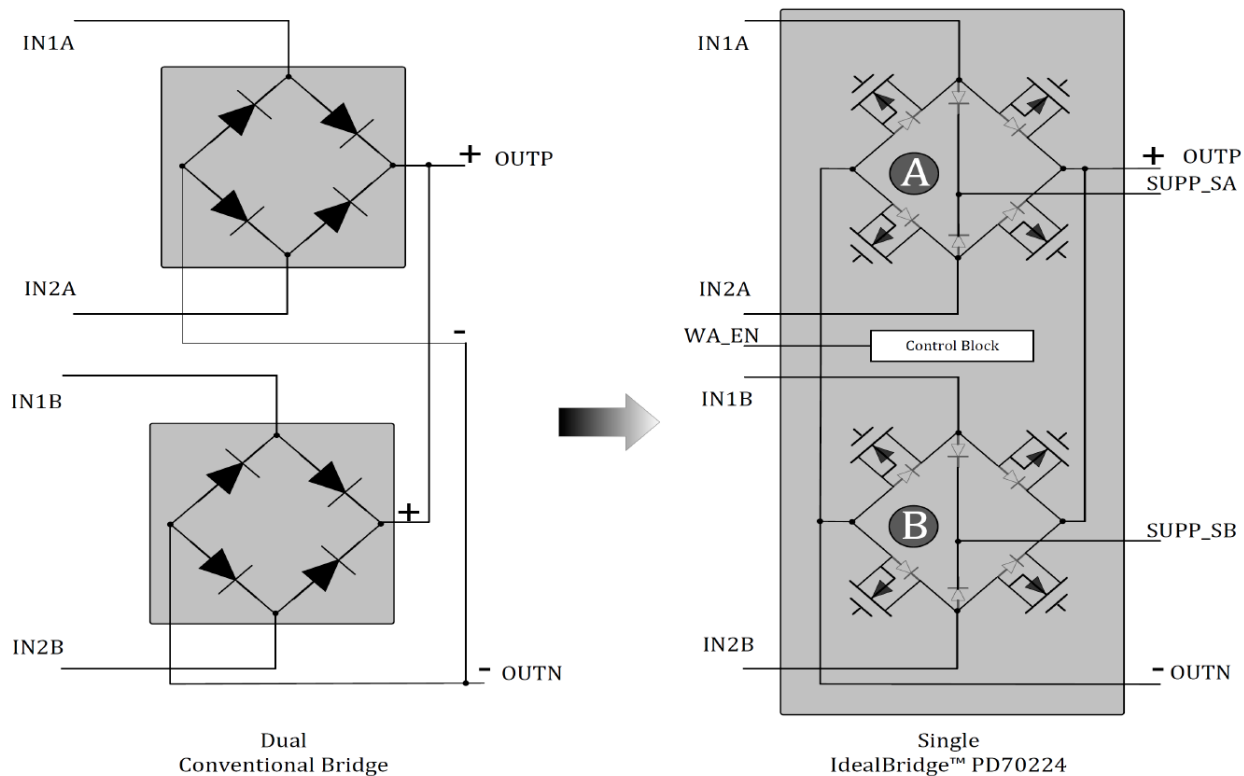
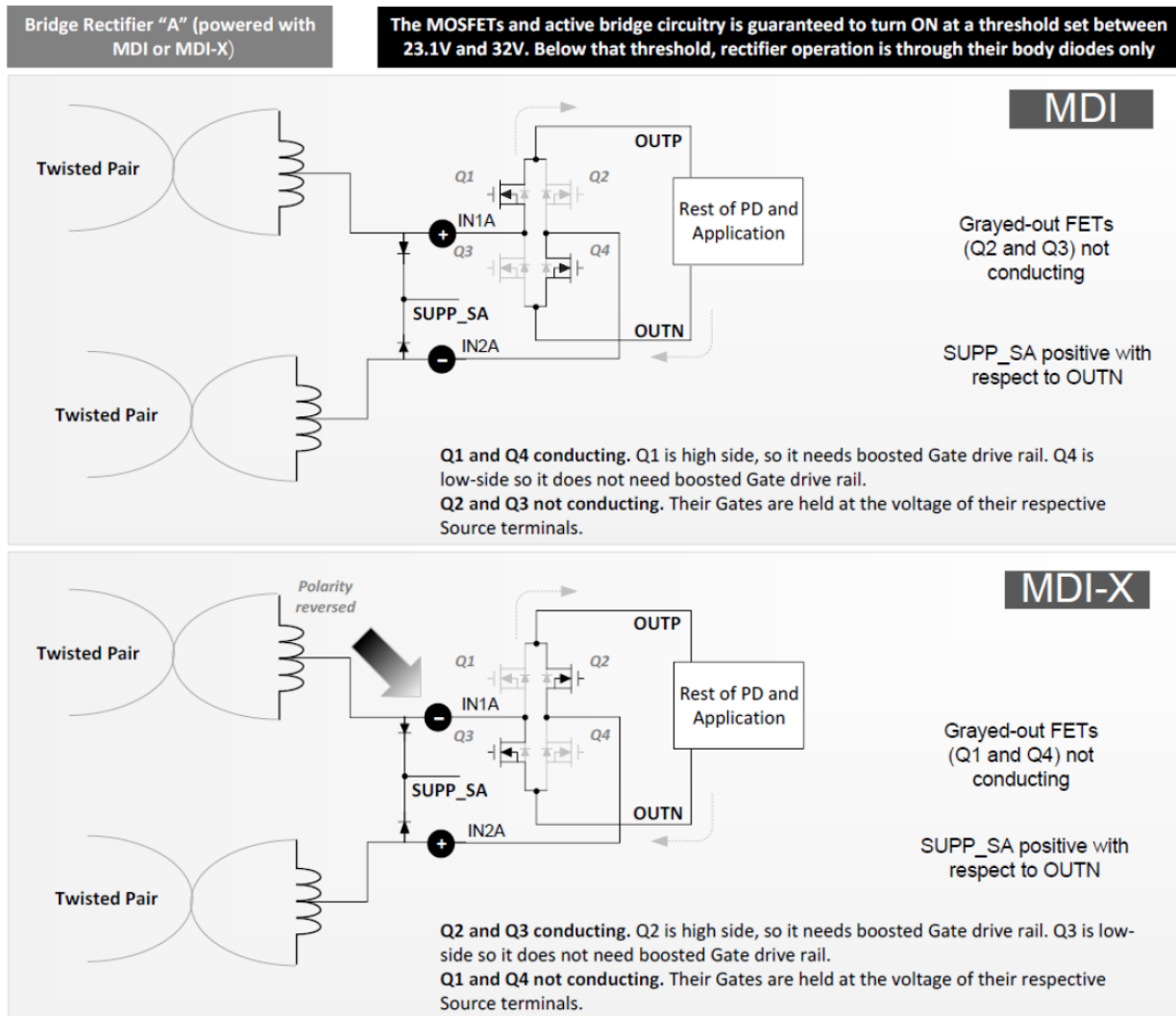

Figure 1-2. Block Diagram



1.1 Purpose of Charge Pump

The FETs connected to OUTP (the high-side FETs) are the ones that require a boosted gate drive rail so they can be turned ON. The on-chip charge pump provides the boosted gate drive rail for the high-side FETs. The FETs connected to OUTN (low-side FETs) do not need a boosted drive rail to be turned ON.

1.2 Purpose and Use of Supply Pins

As the twisted pair set is delivering power, SUPP_SA is positive with respect to OUTN. But if these two twisted pairs were not connected to a PSE, SUPP_SA would be low. The presence of high voltage on SUPP_SA and/or SUPP_SB indicates whether the data pairs or spare pairs, or both, are connected to PSEs. The SUPP_SA and SUPP_SB can be used to indicate 2-pair or 4-pair PoE operation.

2. Electrical Specifications

The following section describes the electrical specifications of the device.

2.1 Absolute Maximum Ratings

Performance is not necessarily guaranteed over this entire range. These are maximum stress ratings only. Exceeding these ratings, even momentarily, can cause immediate damage, or negatively impact long-term operating reliability.

Table 2-1. Absolute Maximum Ratings

Parameter	Min	Max	Units	
IN1A, IN1B, IN2A, IN2B to OUTN	-0.3	74	V	
IN1A to IN2A	-0.3	74	V	
IN1B to IN2B	-0.3	74	V	
IN1A, IN1B, IN2A, IN2B to OUTP	-74	—	V	
IN1A, IN2A to IN1B	-0.3	74	V	
IN1A, IN2A to IN2B	-0.3	74	V	
OUTP to OUTN	-0.3	74	V	
OUTP to IN1A, IN1B, IN2A, IN2B	-0.3	74	V	
SUPP_SA, SUPP_SB to OUTN	-0.3	74	V	
WA_EN to OUTN	-0.3	5.5	V	
I_{INA} , I_{INB} (currents through bridge A or B)	—	2.0	A	
Junction temperature	—	150	°C	
Lead soldering temperature (40 s, reflow)	—	260	°C	
Storage temperature	-65	150	°C	
ESD rating	HBM	—	$\pm 1250^1$	V
	MM	—	± 100	V
	CDM	—	± 2000	V

1. All pins pass 1250 V, except IN1A and IN2A that pass 1000 V.

Note: EPAD1 is connected by copper plane on PCB to OUTP, and EPAD2 is similarly connected to OUTN. OUTN is ground for IC.

2.2 Operating Ratings

Performance is generally guaranteed over this range as provided under [Electrical Characteristics](#).

Table 2-2. Operating Ratings

Parameter	Min	Max	Units
IN1A, IN1B to OUTN	—	57	V
IN2A, IN2B to OUTN	—	57	V
WA_EN to OUTN	-0.3	5	V
Junction temperature	-40	125	°C
Port current (I_{INx})	0	1.5	A

2.3 Electrical Characteristics

Unless otherwise specified under conditions, the Min and Max ratings stated below apply over the entire specified operating ratings of the device. Typical values stated are either by design or by production testing at 25 °C ambient.

Table 2-3. Typical Electrical Performance

Symbol	Parameter	Conditions	Min	Typ	Max	Units
V_{INx}	Input Voltage for Bridge “x”, where x is “A” or “B”	—	—	—	57	V
ΔI_Q	Differential Quiescent Current $I(V_{IN}=10.1\text{ V}) - I(V_{IN}=2.5\text{ V})$;	$2.5\text{ V} < V_{INx} < 10.1\text{ V}$; No load between OUTP and OUTN; No load on SUPP_Sx pins.	—	6	10	μA
I_Q	Quiescent Current (single bridge)	$10.2\text{ V} < V_{INx} < 23\text{ V}$; No load between OUTP and OUTN; No load on SUPP_Sx pins.	—	—	85	μA
	Quiescent Current (both bridge combined)	$V_{INx} = 55\text{ V}$; No load between OUTP and OUTN; No load on SUPP_Sx pins.	—	—	900	μA
V_{TURN_ON}	Active turn-on voltage of FETs	—	23.1	27.5	32	V
V_{HYST}	Turn-on voltage hysteresis	—	—	0.4	—	V
T_{ALT}	Alternate input voltage polarity – Delay time required ($V_{IN} = 0\text{ V}$) while alternating input voltage polarity	—	200	—	—	ms
V_{OFFSET}	Bridge offset at OFF state	$V_{INx} < V_{TURN_ON}$, two body diodes in series $I_{INx} = 40\text{ mA}$	—	—	1.8	V

PD70224

Electrical Specifications

.....continued						
Symbol	Parameter	Conditions	Min	Typ	Max	Units
R _{DS}	FET drain to source resistance	I _D = 0.6A T _J = 25°C	—	0.16	0.26	Ω
		I _D = 0.6A; -40°C ≤ T _J ≤ 125°C	—	—	0.38	Ω
I _R	Leakage current (reverse)	V _{OUTP} - V _{OUTN} = 57V	—	—	80	μA
V _{BFD}	Backfeed voltage	Between input terminals with 100 kΩ resistor across them and 57V between OUTP and OUTN	—	—	2.7	V
I _{MAX_Off}	Maximum forward current (per bridge) below V _{TURN_ON}	—	—	—	0.45	A
I _{MAX_On}	Maximum forward current (per bridge) above V _{TURN_ON} (per bridge, while only one bridge out of the two is active)	—	—	—	1.5	A
I _{MAX_LOAD}	Maximum load current (per device) above V _{TURN_ON} (per device while two bridges are active and each bridge is supporting half load)	—	—	—	2	A
V _{D_SUPP}	Maximum voltage drop between IN _x to SUPP _{Sx} pins	Supp _{Sx} loaded with 100 kΩ resistor	—	—	2	V
I _{MAX_SUPP}	Maximum current to consume from SUPP _{Sx} pins	—	—	—	10	mA
V _{IH}	WA_EN – Input high logic	—	1.35	—	—	V
V _{IL}	WA_EN – Input low logic	—	—	—	1.05	V

Figure 2-1. Safe Operating Area

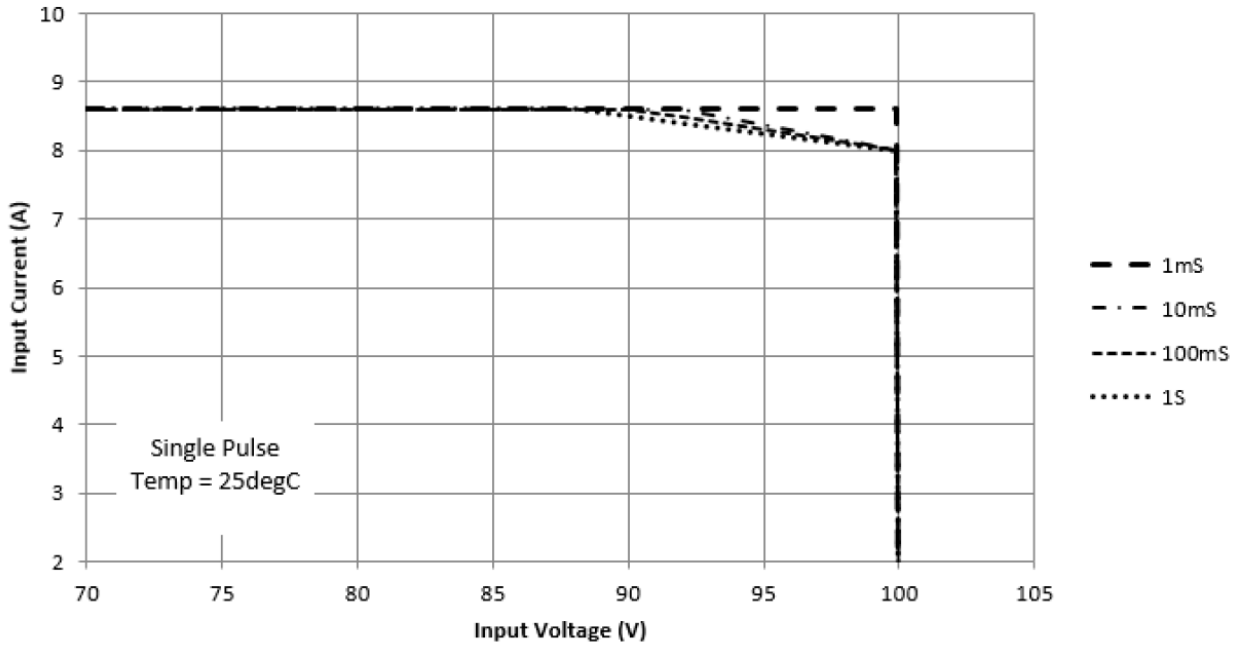

The PD70224L SOA is based on measuring the SOA of a single NMOS device that is used to construct the diode bridge.

Figure 2-2. SOA Test Setup

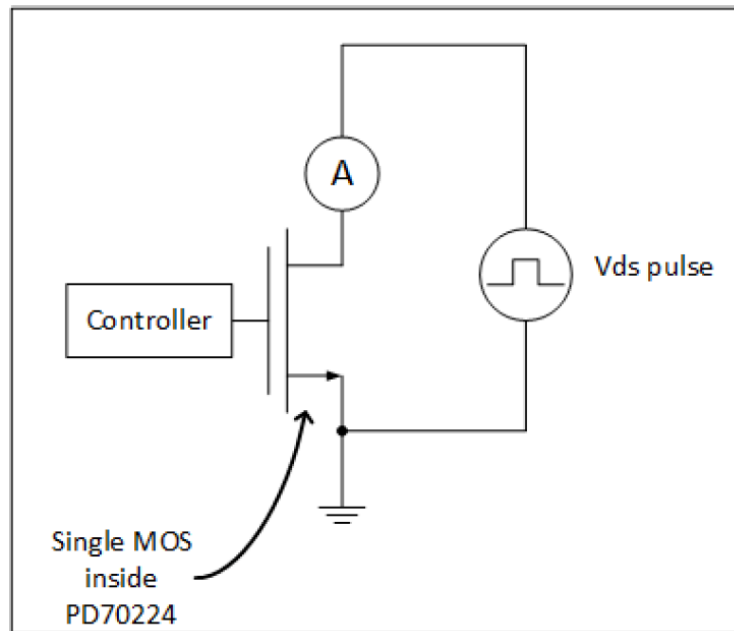

This data is provided for information purposes. For additional information on surge immunity and Microchip recommendations, please see [AN3410—Design for PD System Surge Immunity PD701xx and PD702xx](#).

3. Pin Descriptions

The following illustration is a representation of PD70224 device, as seen from the top and bottom view.

Figure 3-1. Internal Construction and Pinout

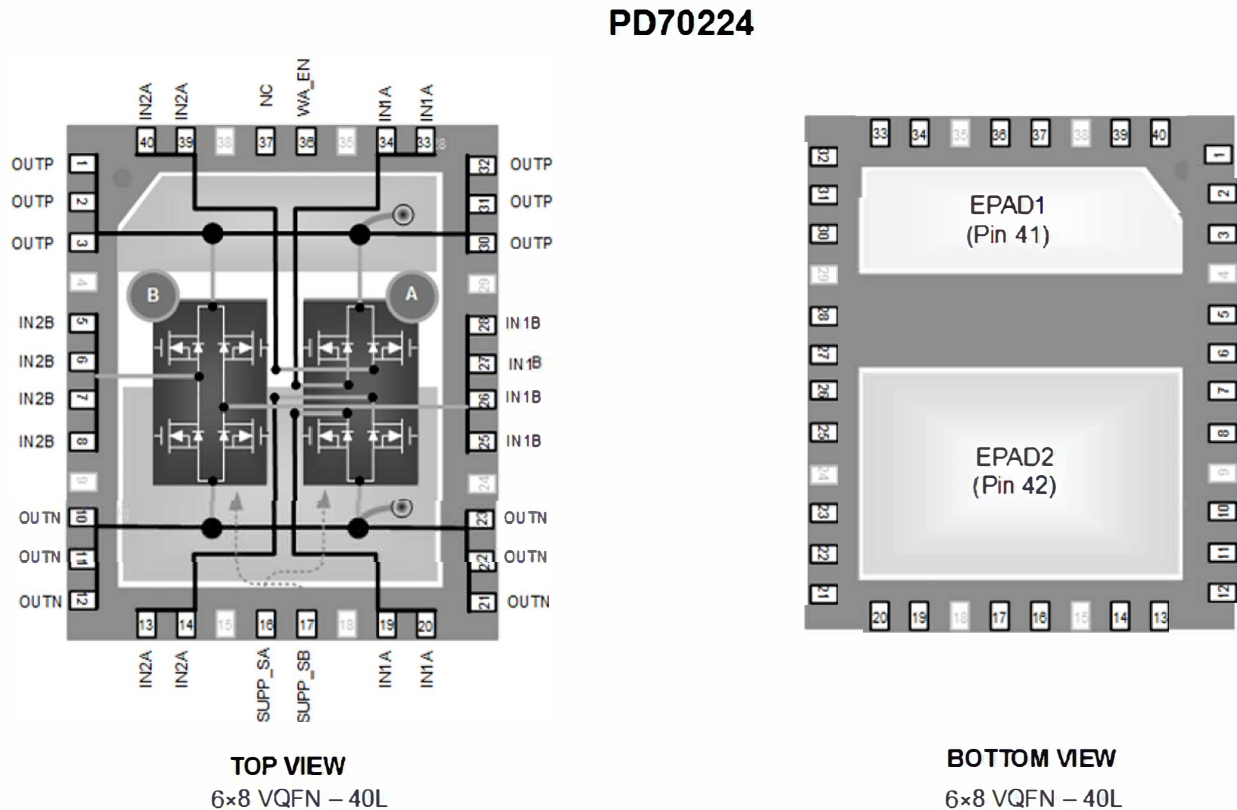

Table 3-1. Pin Description

Pin Number	Pin Designator	Description
PD70224		
VQFN 40 Lead		
1, 2, 3	OUTP	Rectified positive (upper) rail shared by both bridges
4	N.A.	Not applicable (pin not present)
5, 6, 7, 8	IN2B	Input “2” of bridge rectifier number B
9	N.A.	Not applicable (pin not present)
10, 11, 12	OUTN	Rectified negative (lower) rail shared by both bridges
13, 14	IN2A	Input “2” of bridge rectifier number A (same as pins 39 and 40) ¹
15	N.A.	Not applicable (pin not present)
16	SUPP_SA	Input power supply detect pin for bride rectifier number A. Goes high when pairs connected to this bridge are powered by the PSE.
	N.A.	Not applicable (pin not present)
17	SUPP_SB	Input power supply detect pin for bride rectifier number B. Goes high when pairs connected to this bridge are powered by the PSE.

.....continued		
Pin Number PD70224 VQFN 40 Lead	Pin Designator	Description
18	N.A.	Not applicable (pin not present)
19, 20	IN1A	Input “1” of bridge rectifier number A. ²
21, 22, 23	OUTN	Rectified negative (lower) rail shared by both bridges (same as pins 10, 11, and 12)
24	N.A.	Not applicable (pin not present)
25, 26, 27, 28	IN1B	Input “1” of bridge rectifier number B
29	N.A.	Not applicable (pin not present)
30, 31, 32	OUTP	Rectified positive (upper) rail shared by both bridges (same as pins 1, 2, and 3)
33, 34	IN1A	Input “1” of bridge rectifier number A (same as pins 19 and 20) ³
35	N.A.	Not applicable (pin not present)
36	WA_EN	While this input is low (referenced to OUTN), the chip work according to internal flow diagram. When this input is high, it enable wall adapter feature, that is, turn OFF internal switches and act as regular diode bridge.
	N.A.	Not applicable (pin not present)
37	N.C.	Not connected; do not connect externally (leave floating)
38	N.A.	Not applicable (pin not present)
39, 40	IN2A	Input “2” of bridge rectifier number A (same as pins 13 and 14) ⁴
41	EPAD1	Connect to OUTP on PCB
42	EPAD2	Connect to OUTN on PCB

Notes:

1. These pins are not shorted to pins 39 and 40 inside the device. The device functionality relies on a copper trace on the PCB, between pins 13, 14, 39, and 40.
2. These pins are not shorted to pins 33 and 34 inside the device. The device functionality relies on a copper trace on the PCB, between pins 33, 34, 19, and 20.
3. These pins are not shorted to pins 19 and 20 inside the device. The device functionality relies on a copper trace on the PCB, between pins 33, 34, 19, and 20.
4. These pins are not shorted to pins 13 and 14 inside the device. The device functionality relies on a copper trace on the PCB, between pins 13, 14, 39, and 40.

4. Package Specification

The following section shows the package specification of the PD70224 device.

4.1 Package Outline Drawing

The following figure shows the package outline drawing of PD70224 device. The dimensions in the following figure are in millimeters.

Figure 4-1. PD70224 Package Outline Drawing 40-Pin QFN 6 mm × 8 mm

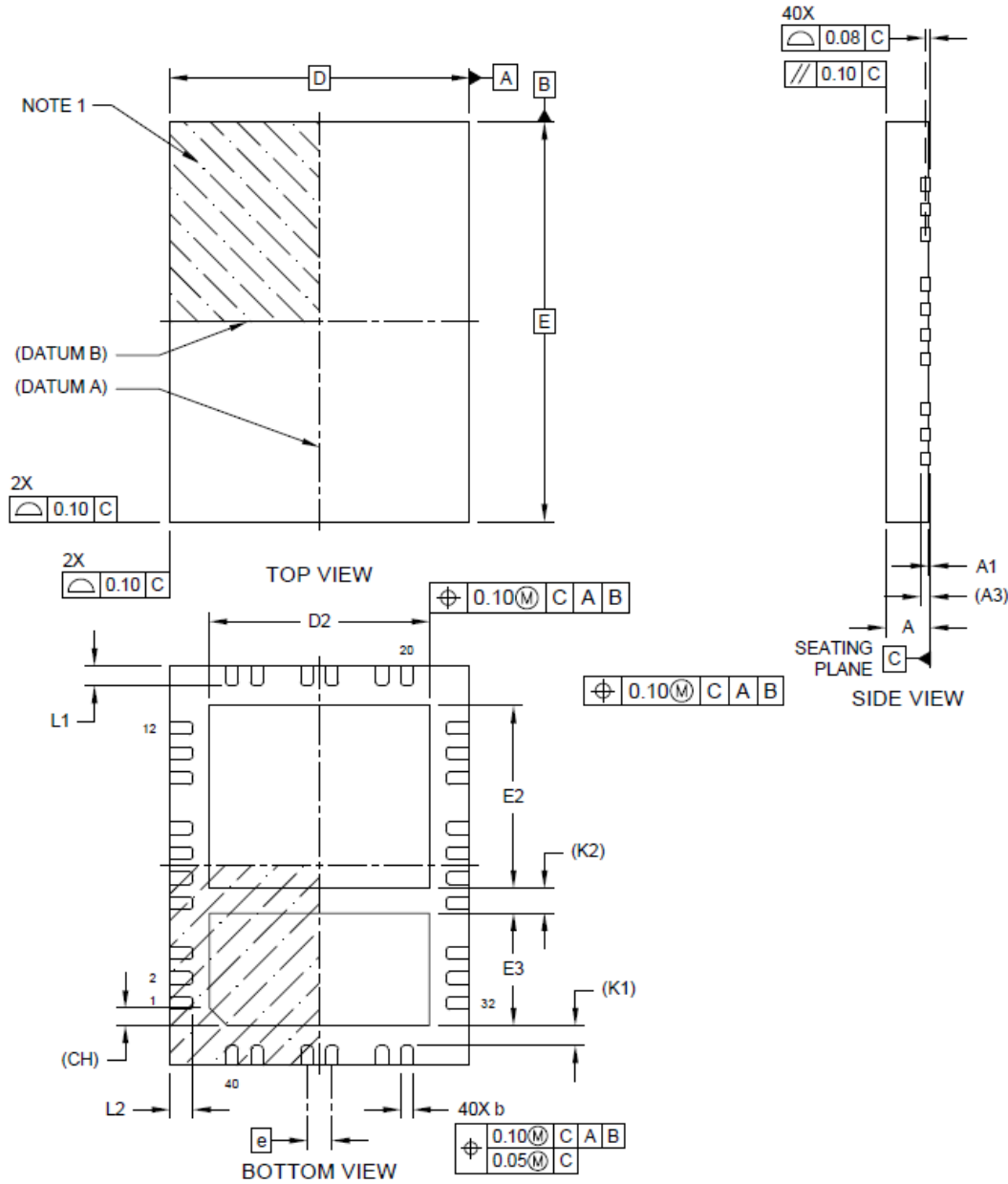

Table 4-1. Package Measurements

Units		Millimeter		
Dimension Limits		Minimum	Nominal	Maximum
Number of Terminals	N	40		
Pitch	e	0.50 BSC		
Overall Height	A	0.80	0.90	1.00
Standoff	A1	0.00	0.02	0.05
Terminal Thickness	A3	0.20 REF		
Overall Length	D	6.00 BSC		
Exposed Pad Length	D2	4.30	4.40	4.50
Overall Width	E	8.00 BSC		
Exposed Pad Width	E2	3.65 REF		
Exposed Pad Width	E3	2.25 REF		
Terminal Width	b	0.20	0.25	0.30
Terminal Length (Short Side)	L1	0.35	0.40	0.45
Terminal Length (Long Side)	L2	0.42	0.47	0.52
Terminal-to-Exposed-Pad	K1	0.40 REF		
Exposed Pad-to-Exposed-Pad	K2	0.50 REF		
Index Corner Chamfer	CH	0.35 REF		

Notes:

1. Pin 1 visual index feature may vary, but must be located within the hatched area.
2. The package is saw singulated.
3. Dimensioning and tolerancing per ASME Y14.5M.
 - a. BSC: Basic Dimension, theoretically exact value shown without tolerances.
 - b. REF: Reference Dimension, usually without tolerance and for information purposes only.

For the latest package drawings, see the Microchip Packaging Specification located at www.microchip.com/packaging.

4.2 Thermal Specifications

The following table lists the thermal specifications of PD70224.

Table 4-2. Thermal Properties

Thermal Resistance	Min	Typ	Max	Units
θ_{JA}	—	31	—	°C/W
θ_{JL}	—	2.5	—	°C/W
θ_{JC}	—	5	—	°C/W

Note: The θ_{jx} numbers assume no forced airflow. Junction temperature is calculated using $T_J = T_A + (P_D \times \theta_{JA})$. In particular, θ_{JA} is a function of the PCB construction. The stated number above is for a four-layer board in accordance with JESD-51 (JEDEC).

4.3 Recommended PCB Layout

The following figures show the PD70224 PCB layout based on the IPC7093A (October 2020 Standard). All previously published footprints are still supported.

The pad for pins 4, 9, 15, 18, 24, 29, 35, and 38 is missing from the layout because it does not exist in package.

Figure 4-2. Solder Mask—Top View

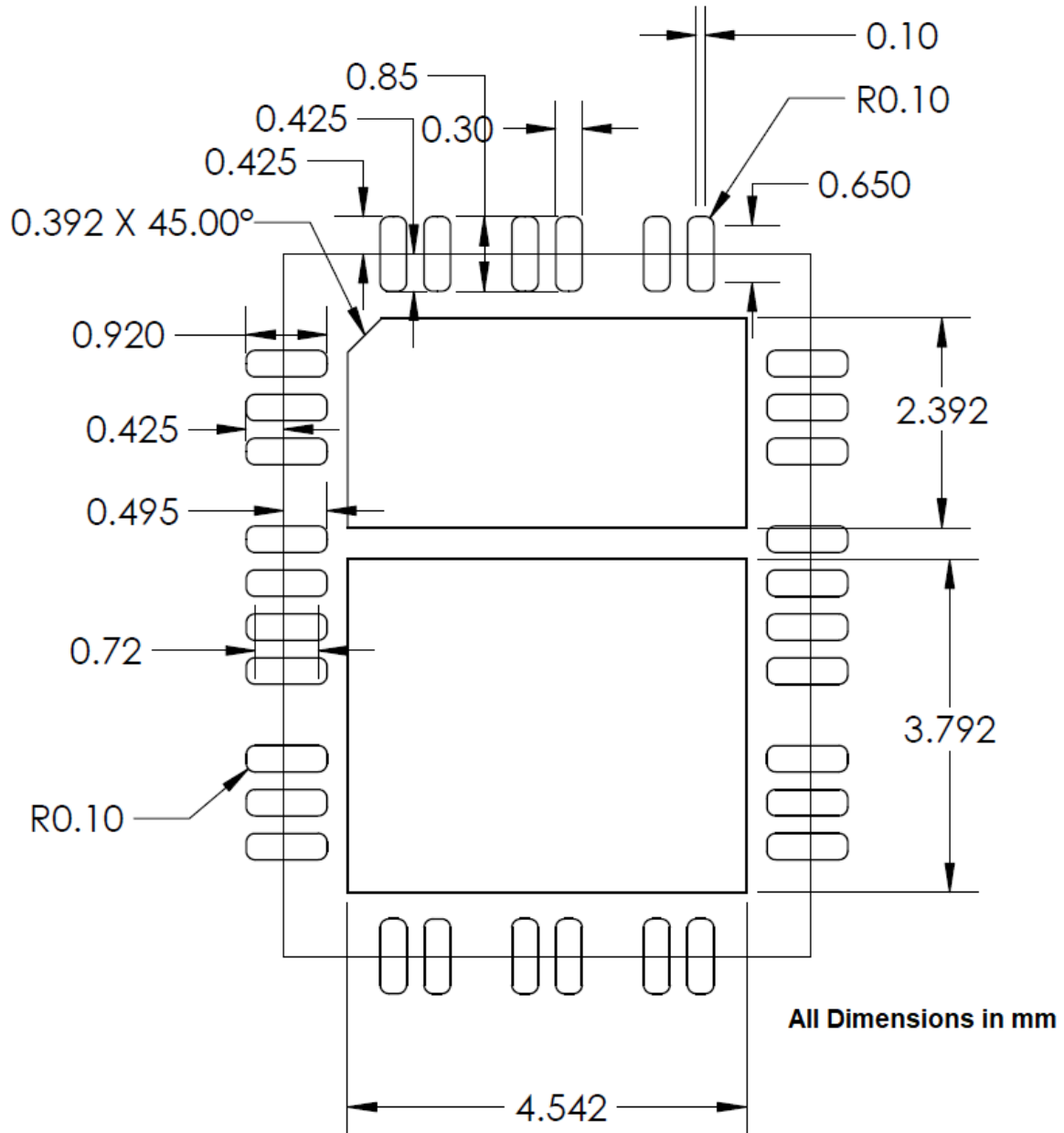
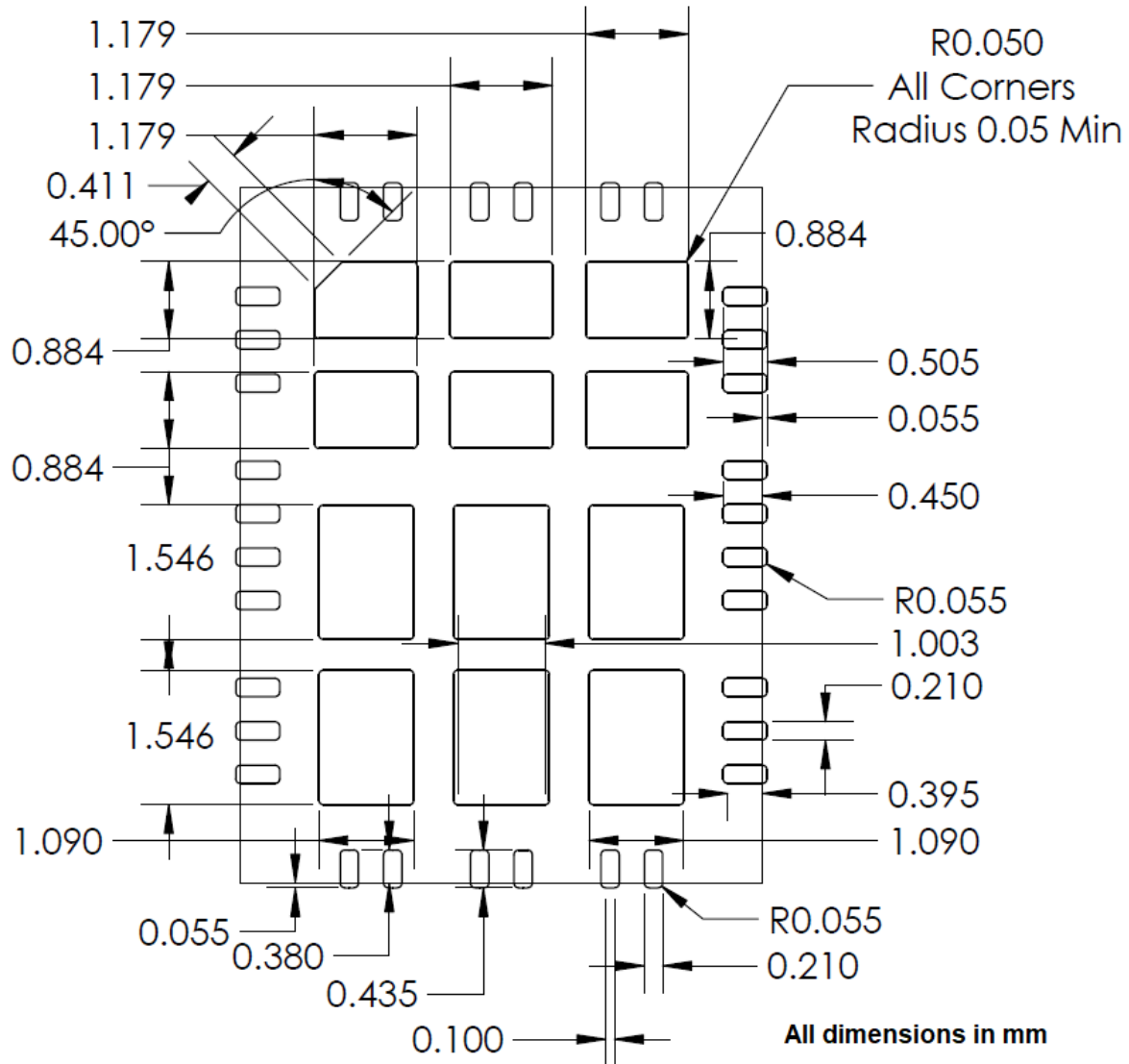

Figure 4-4. Paste Mask—Top View



Note: Paste mask stencil is 5 mil thick. All paste mask openings have a radius of 0.05 mm.

Figure 4-5. Pin Geometry—Long Side

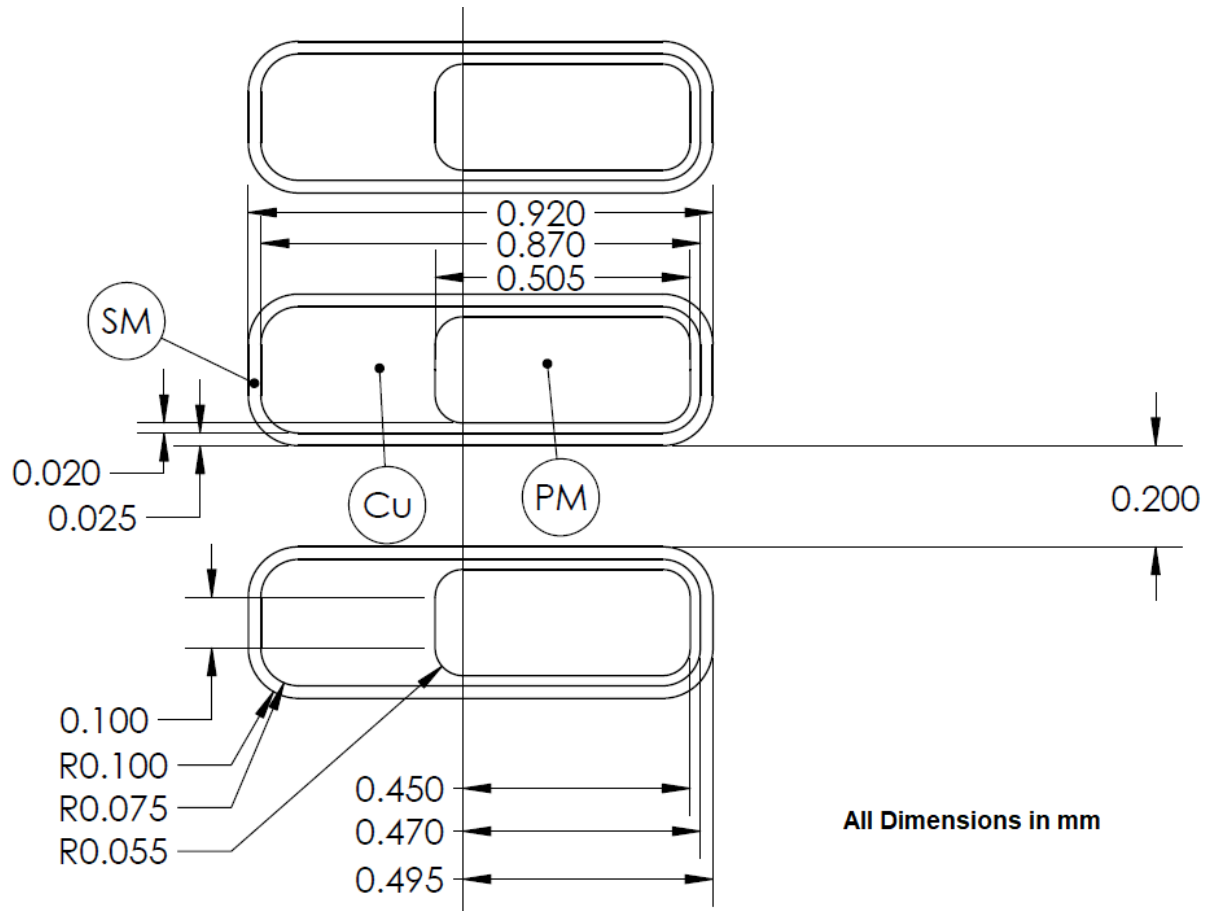
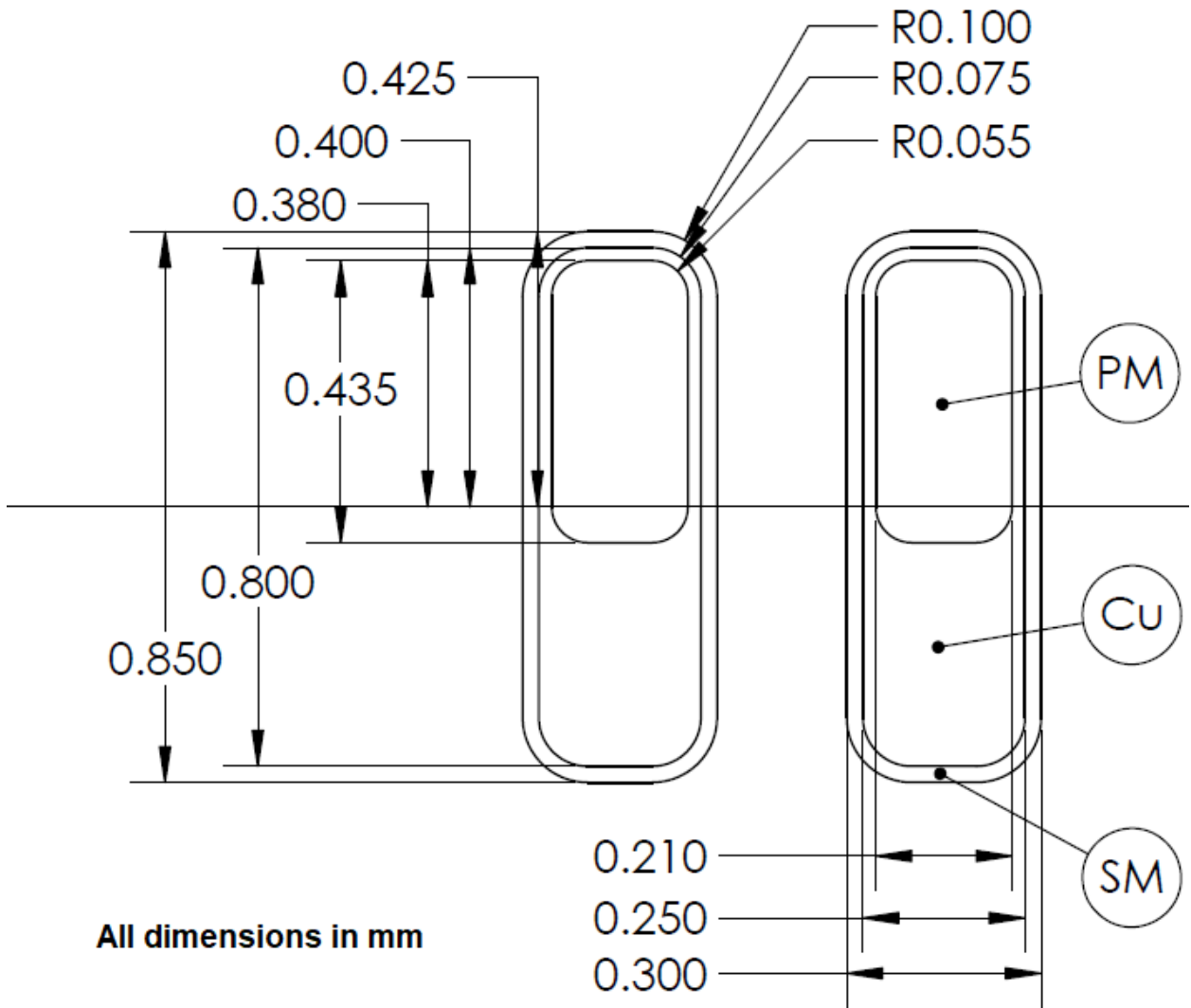

Figure 4-6. Pin Geometry—Short Side



5. Application Information

The following section describes the application information of the device.

5.1 Peripheral Devices

PD applications utilizing PD70224 IC should use 1 nF/100V ceramic capacitor at Bridge A inputs and at Bridge B inputs.

For surge and ESD protection, refer to [AN3410, Design for PD System Surge Immunity PD701xx PD702xx](#).

A 10 kΩ resistor should be placed on SUPP_SA and SUPP_SB lines between PD70224 and PD70210A.

When WA_EN function is not used, connect WA_EN pin to OUTN Pin.

When WA_EN function is used, connect a capacitor (1 nF to 100 nF/10V) between WA_EN pin and OUTN Pin.

The devices are presented in the figures PD70224 Package Outline Drawing 40-Pin QFN 6 mm × 8 mm and PD70224 Top layer Copper Recommended PCB Layout (mm).

5.2 Operation with an External DC Source

PD applications utilizing the PD70224 IC may be operated with an external power source (DC wall adapter). There are two cases of providing power with an external source, as shown in the following figures.

Note: Protection is not shown in either figures, see application note [AN3410—Design for PD System Surge Immunity PD701xx and PD702xx](#) for recommended protection scheme.

1. An external source is connected to the application's low voltage supply rails. The external source voltage level depends on DCDC output characteristics; this connection is not affected by the PD70224 use.
2. External source connected to PD device output connection toward the application (VPP to VPNOUT). External source voltage level is dependent on DCDC input requirements.

Figure 5-1. External Power Input Connected to Application Supply Rails

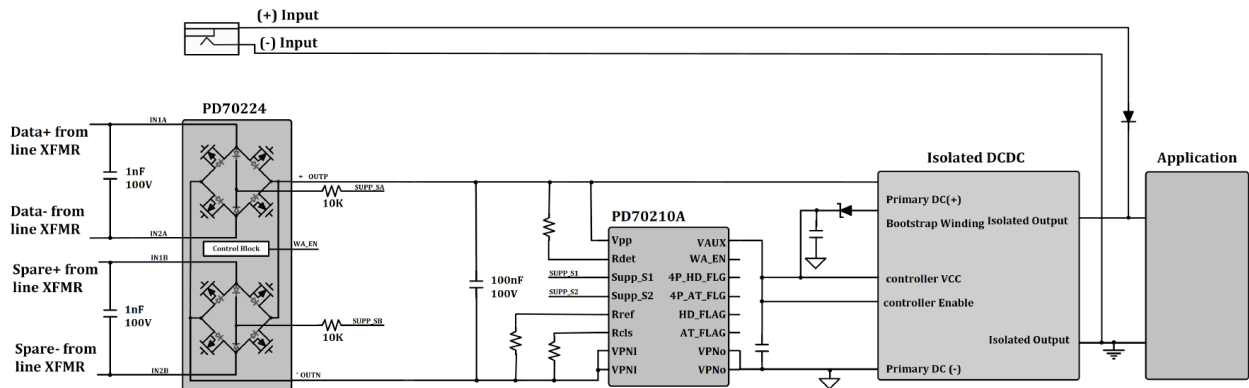
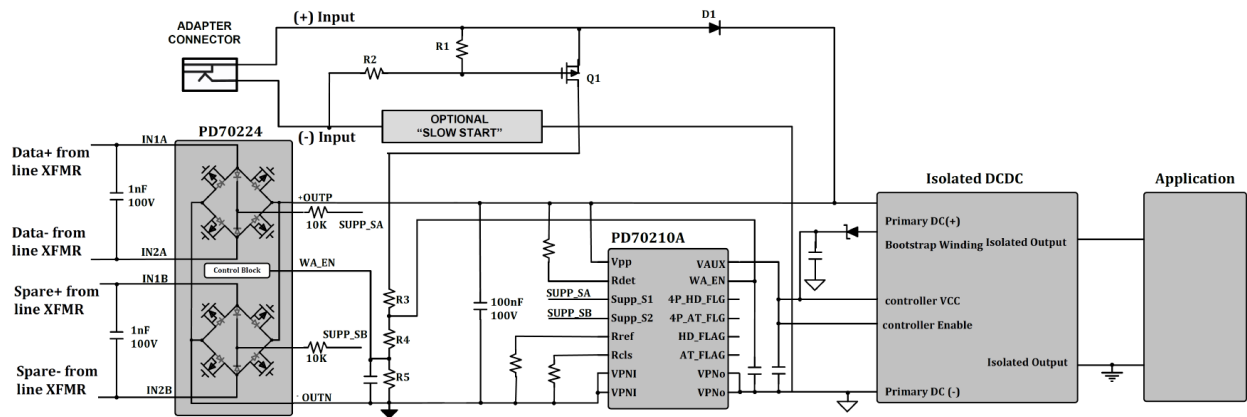

Figure 5-2. External Power Input Connected to PD70210A Output



5.2.1 External Source Connected to PD Device Output

The PD70224 WA_EN pin will be used for protecting the PSE when an external adapter is connected. In this mode, the risk to PSE side exists when a higher voltage external adapter is hot connected to the system. When the WA_EN input voltage is higher than its threshold level, PD70224 internal FETs are disabled, converting the device into standard diode bridge. The PD70210A also has a specific input pin, to disable the isolation switch, when an external adapter is connected.

In this case, WA_EN resistors divider depends on the “turn off” threshold of the PD70210A and PD70224.

Zooming into the resistors to be selected in external adapter connection.

Figure 5-3. External Power Input Resistors Dividers

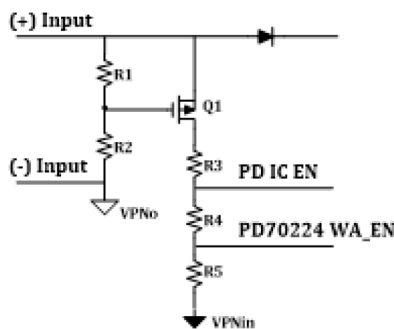

R1 and R2 sets a rough threshold for PFET Q1 enable to detect whether external adapter exists or not. It should be set to be lower threshold than PD70224 and PD70210A disable levels. R3, R4, and R5 set PD70210A disable threshold and PD70224 disable threshold. The PD70210A disable threshold should be set so that it will always be lower than PD70224 disable threshold. 1V is a good choice for the margin between the two. So, in case of 44V–57V external adapter, the disable setting can be selected as follows:

- PFET enable threshold = 35V
- PD70224 disable threshold = 43V

R1 and R2 setting should be so that the value of Q1 VGS < 20V at max voltage condition of external adapter. While external adapter voltage is above 35V, Q1 will be above its VGSth value.

$$VGS = V_{ext_adapter} \times \frac{R1}{R1 + R2}$$

Suppose VGSth is 3.5V, thus we will set VGS= 5V.

R1 is selected as 2 kΩ.

$$R2 = R1 \times \frac{Vext_adapter - VGS}{VGS}$$

Using R1= 2 kΩ, Vext_adapter= 30V and VGS= maximum VGStH= 3.5V. We get R2 value.

$$R2 = 15K\Omega$$

$$= PD70210A_Wa_en = Vext_adapter_PD70210A \times \frac{R4}{(R3 + R4)}$$

$$R2 = R1 \times \frac{Vext_adapter - VGS}{VGS}$$

R2 = 60 kΩ. R3, R4, and R5 are set using the following two equations.

$$(I) \quad PD70224_Wa_en = Vext_adapter_PD70224 \times \frac{R5}{(R3+R4+R5)}$$

$$(II) \quad PD70210A_Wa_en = Vext_adapter_PD70210A \times \frac{R4+R5}{(R3+R4+R5)}$$

Set R3, R4, and R5 up to few kΩ.

At equation (I) set Vext_adapter_PD70224= 44V and from PD70224 datasheet, PD70224 _WA_EN=1.35V.

At equation (II) set Vext_adapter_PD70210A= (minimum Vext_adapter_PD70224 -1 V) and from PD_IC data sheet PD70210A_WA_EN= 2.4V.

R5 is selected as 620Ω.

Solving the two equations plus accuracy and verifying that PD70210A is always disconnected before PD70224, we get the optimum resistors values for an adapter of adapter of 36V and above.

$$R3 = 15K\Omega$$

$$R4 = 820\Omega$$

$$R5 = 620\Omega$$

For more details and different connection configurations, see [AN3472-Implementing Aux Power in PoE](#).

6. Design Example

The following four figures show the layout of PD70224 EVB evaluation board.

The board is two layers PCB. U2 is PD70224.

This board can be ordered from Microchip.

Figure 6-1. PD70224 EVB PCB Silk Top

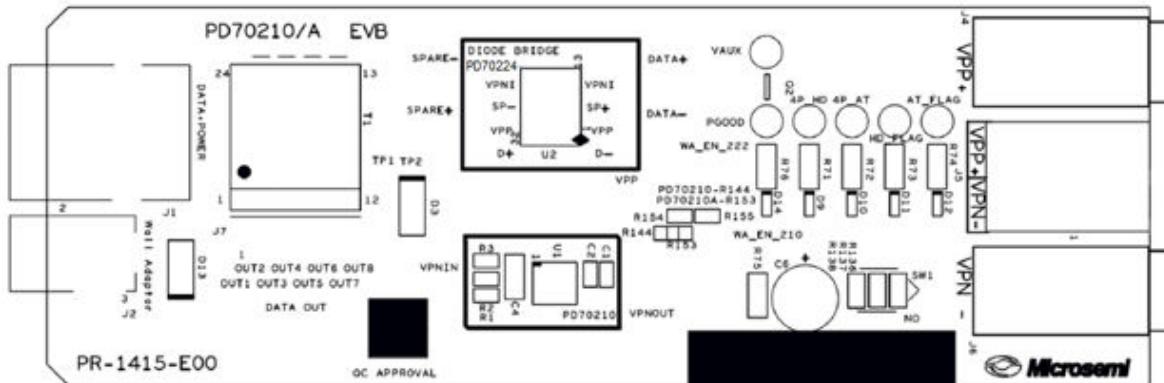

Figure 6-2. PD70224 EVB PCB Silk Bottom

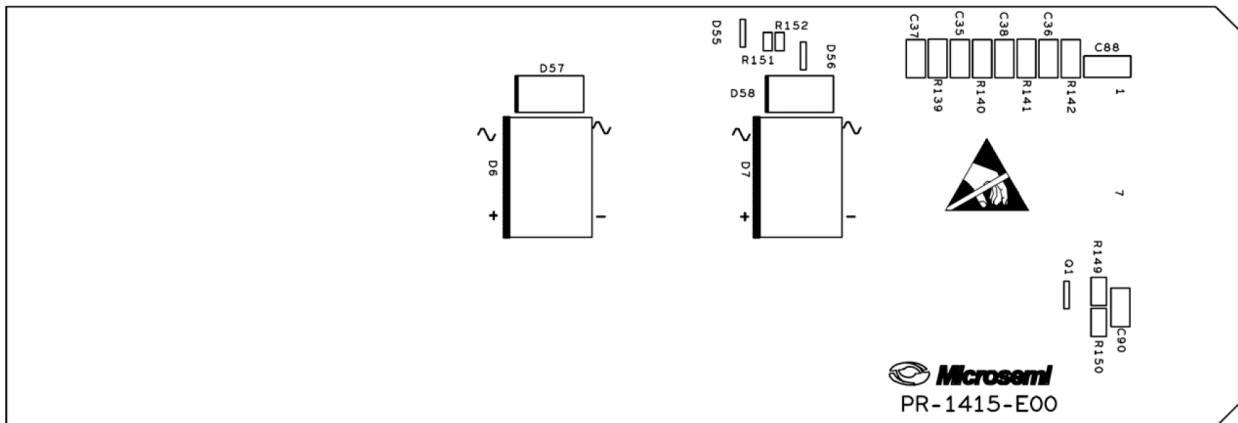

Figure 6-3. PD70224 EVB PCB Top Copper

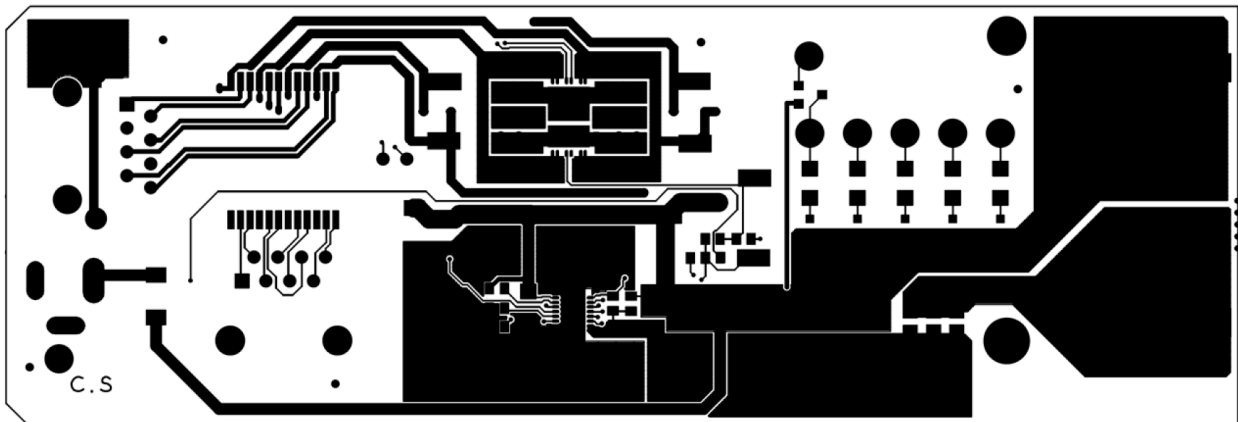
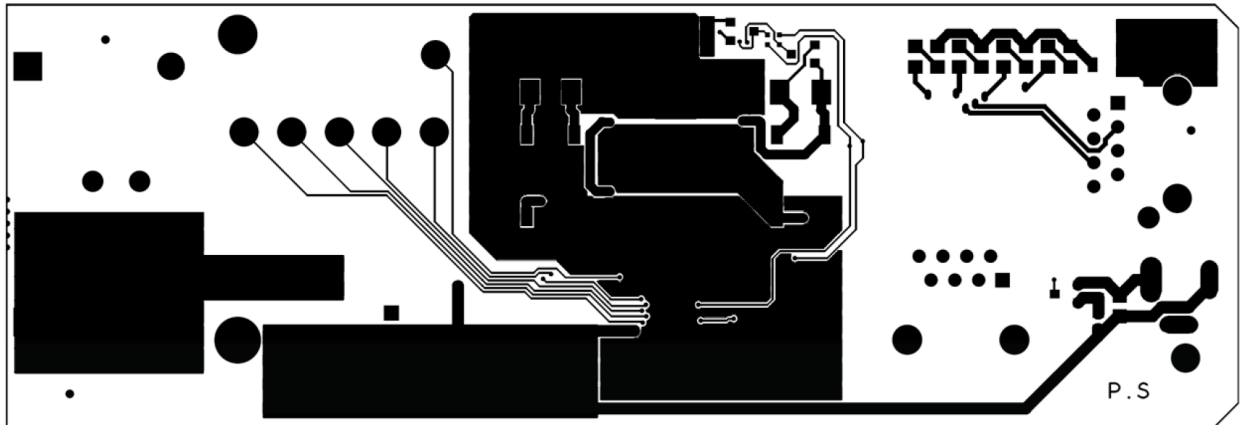

Figure 6-4. PD70224 EVB PCB Bottom Copper



7. Ordering Information

The following table lists the ordering information of the PD70224 device.

Table 7-1. Ordering Information

Part Number	Ambient Temperature	Type	Package	Packaging Type	Part Marking
PD70224ILQ-TR	-40 °C to 85 °C	RoHS compliant Pb free MSL3	QFN (40 lead)	Tape and reel	Microchip Logo PD70224 ZZ e4 ¹ YYWWNNN

1. ZZ e4: ZZ= Random character with no meaning, e4 = Second-level interconnect.
2. YY= Year, WW= Week, NNN= Trace code.

8. Technical Support and Documentation

For technical support visit the Microchip Technical Support Portal at: www.microchip.com/support.

For access to any related application note or documentation please consult your local Microchip Client Engagement Manager or visit our website at www.microchip.com/poe.

9. Revision History

Revision	Date	Description
D	09/2021	The following is a summary of changes in revision D of this document. <ul style="list-style-type: none"> Updated the 4.1. Package Outline Drawing section. Updated the 4.3. Recommended PCB Layout section.
C	10/2020	Updated a typo for a value of K in the Package Measurements table.
B	09/2020	The following is a summary of changes in revision C of this document. <ul style="list-style-type: none"> Updated the Introduction section. Added 8. Technical Support and Documentation section. Updated the values of K in the Package Measurements table. Updated the Internal Construction and Pinout figure. Updated the 4.3. Recommended PCB Layout section. Updated the PD70224 EVB PCB Silk Top figure. Updated the Ordering Information table.
A	07/2020	<ul style="list-style-type: none"> Updated to Microchip format. Updated document number from PD-000307871 to DS00003590. Deleted figure "PD70224 Bottom Layer Copper and Solder Paste Recommended PCB Layout for Thermal Pad Array (mm)" in the Recommended PCB Layout section.
3.0	08/2019	Updated the package marking in the Ordering Information section.
2.0	02/2018	<ul style="list-style-type: none"> Updated part marking. Updated figure External Power Input Connected to PD70210A Output. Added MSL3 compliance. Updated Safe Operating Area graph to show test methodology and discuss protection recommendations. Moved Recommended Protection Scheme to the application note "Design for PD System Surge Immunity".
1.3	05/2016	Updated Figure 7 with optional slow start circuit.
1.2	11/2014	<ul style="list-style-type: none"> Removed watermark. Updated ESD with IN1A/IN2A 1000V note.
1.1	07/2015	Updated ESD.
1.0	08/2014	<ul style="list-style-type: none"> Added maximum SUPP_Sx current, application information, and SOA graph. Updated MSL level.
0.73	06/2014	Updated leadframe for thermal pad.
0.72	05/2014	Added dimensions to recommended layout IMAX_LOAD.
0.7	05/2014	Initial Revision

The Microchip Website

Microchip provides online support via our website at www.microchip.com/. This website is used to make files and information easily available to customers. Some of the content available includes:

- **Product Support** – Data sheets and errata, application notes and sample programs, design resources, user's guides and hardware support documents, latest software releases and archived software
- **General Technical Support** – Frequently Asked Questions (FAQs), technical support requests, online discussion groups, Microchip design partner program member listing
- **Business of Microchip** – Product selector and ordering guides, latest Microchip press releases, listing of seminars and events, listings of Microchip sales offices, distributors and factory representatives

Product Change Notification Service

Microchip's product change notification service helps keep customers current on Microchip products. Subscribers will receive email notification whenever there are changes, updates, revisions or errata related to a specified product family or development tool of interest.

To register, go to www.microchip.com/pcn and follow the registration instructions.

Customer Support

Users of Microchip products can receive assistance through several channels:

- Distributor or Representative
- Local Sales Office
- Embedded Solutions Engineer (ESE)
- Technical Support

Customers should contact their distributor, representative or ESE for support. Local sales offices are also available to help customers. A listing of sales offices and locations is included in this document.

Technical support is available through the website at: www.microchip.com/support

Microchip Devices Code Protection Feature

Note the following details of the code protection feature on Microchip devices:

- Microchip products meet the specification contained in their particular Microchip Data Sheet.
- Microchip believes that its family of products is one of the most secure families of its kind on the market today, when used in the intended manner and under normal conditions.
- There are dishonest and possibly illegal methods used to breach the code protection feature. All of these methods, to our knowledge, require using the Microchip products in a manner outside the operating specifications contained in Microchip's Data Sheets. Most likely, the person doing so is engaged in theft of intellectual property.
- Microchip is willing to work with the customer who is concerned about the integrity of their code.
- Neither Microchip nor any other semiconductor manufacturer can guarantee the security of their code. Code protection does not mean that we are guaranteeing the product as "unbreakable."

Code protection is constantly evolving. We at Microchip are committed to continuously improving the code protection features of our products. Attempts to break Microchip's code protection feature may be a violation of the Digital Millennium Copyright Act. If such acts allow unauthorized access to your software or other copyrighted work, you may have a right to sue for relief under that Act.

Legal Notice

Information contained in this publication regarding device applications and the like is provided only for your convenience and may be superseded by updates. It is your responsibility to ensure that your application meets with

your specifications. MICROCHIP MAKES NO REPRESENTATIONS OR WARRANTIES OF ANY KIND WHETHER EXPRESS OR IMPLIED, WRITTEN OR ORAL, STATUTORY OR OTHERWISE, RELATED TO THE INFORMATION, INCLUDING BUT NOT LIMITED TO ITS CONDITION, QUALITY, PERFORMANCE, MERCHANTABILITY OR FITNESS FOR PURPOSE. Microchip disclaims all liability arising from this information and its use. Use of Microchip devices in life support and/or safety applications is entirely at the buyer's risk, and the buyer agrees to defend, indemnify and hold harmless Microchip from any and all damages, claims, suits, or expenses resulting from such use. No licenses are conveyed, implicitly or otherwise, under any Microchip intellectual property rights unless otherwise stated.

Trademarks

The Microchip name and logo, the Microchip logo, Adaptec, AnyRate, AVR, AVR logo, AVR Freaks, BesTime, BitCloud, chipKIT, chipKIT logo, CryptoMemory, CryptoRF, dsPIC, FlashFlex, flexPWR, HELDO, IGLOO, JukeBlox, KeeLoq, Kleer, LANCheck, LinkMD, maXStylus, maXTouch, MediaLB, megaAVR, Microsemi, Microsemi logo, MOST, MOST logo, MPLAB, OptoLyzer, PackeTime, PIC, picoPower, PICSTART, PIC32 logo, PolarFire, Prochip Designer, QTouch, SAM-BA, SenGenuity, SpyNIC, SST, SST Logo, SuperFlash, Symmetricom, SyncServer, Tachyon, TempTrackr, TimeSource, tinyAVR, UNI/O, Vectron, and XMEGA are registered trademarks of Microchip Technology Incorporated in the U.S.A. and other countries.

APT, ClockWorks, The Embedded Control Solutions Company, EtherSynch, FlashTec, Hyper Speed Control, HyperLight Load, IntelliMOS, Libero, motorBench, mTouch, Powermite 3, Precision Edge, ProASIC, ProASIC Plus, ProASIC Plus logo, Quiet-Wire, SmartFusion, SyncWorld, Temux, TimeCesium, TimeHub, TimePictra, TimeProvider, Vite, WinPath, and ZL are registered trademarks of Microchip Technology Incorporated in the U.S.A.

Adjacent Key Suppression, AKS, Analog-for-the-Digital Age, Any Capacitor, AnyIn, AnyOut, BlueSky, BodyCom, CodeGuard, CryptoAuthentication, CryptoAutomotive, CryptoCompanion, CryptoController, dsPICDEM, dsPICDEM.net, Dynamic Average Matching, DAM, ECAN, EtherGREEN, In-Circuit Serial Programming, ICSP, INICnet, Inter-Chip Connectivity, JitterBlocker, KleerNet, KleerNet logo, memBrain, Mindi, MiWi, MPASM, MPF, MPLAB Certified logo, MPLIB, MPLINK, MultiTRAK, NetDetach, Omniscient Code Generation, PICDEM, PICDEM.net, PICkit, PICtail, PowerSmart, PureSilicon, QMatrix, REAL ICE, Ripple Blocker, SAM-ICE, Serial Quad I/O, SMART-I.S., SQL, SuperSwitcher, SuperSwitcher II, Total Endurance, TSHARC, USBCheck, VariSense, ViewSpan, WiperLock, Wireless DNA, and ZENA are trademarks of Microchip Technology Incorporated in the U.S.A. and other countries.

SQTP is a service mark of Microchip Technology Incorporated in the U.S.A.

The Adaptec logo, Frequency on Demand, Silicon Storage Technology, and Symmcom are registered trademarks of Microchip Technology Inc. in other countries.

GestIC is a registered trademark of Microchip Technology Germany II GmbH & Co. KG, a subsidiary of Microchip Technology Inc., in other countries.

All other trademarks mentioned herein are property of their respective companies.

© 2021, Microchip Technology Incorporated, Printed in the U.S.A., All Rights Reserved.

ISBN: 978-1-5224-8942-9

Quality Management System

For information regarding Microchip's Quality Management Systems, please visit www.microchip.com/quality.

Worldwide Sales and Service

AMERICAS	ASIA/PACIFIC	ASIA/PACIFIC	EUROPE
<p>Corporate Office 2355 West Chandler Blvd. Chandler, AZ 85224-6199 Tel: 480-792-7200 Tel: 480-792-7277 Technical Support: www.microchip.com/support Web Address: www.microchip.com</p> <p>Atlanta Duluth, GA Tel: 678-957-9614 Fax: 678-957-1455</p> <p>Austin, TX Tel: 512-257-3370</p> <p>Boston Westborough, MA Tel: 774-760-0087 Fax: 774-760-0088</p> <p>Chicago Itasca, IL Tel: 630-285-0071 Fax: 630-285-0075</p> <p>Dallas Addison, TX Tel: 972-818-7423 Fax: 972-818-2924</p> <p>Detroit Novi, MI Tel: 248-848-4000</p> <p>Houston, TX Tel: 281-894-5983</p> <p>Indianapolis Noblesville, IN Tel: 317-773-8323 Fax: 317-773-5453 Tel: 317-536-2380</p> <p>Los Angeles Mission Viejo, CA Tel: 949-462-9523 Fax: 949-462-9608 Tel: 951-273-7800</p> <p>Raleigh, NC Tel: 919-844-7510</p> <p>New York, NY Tel: 631-435-6000</p> <p>San Jose, CA Tel: 408-735-9110 Tel: 408-436-4270</p> <p>Canada - Toronto Tel: 905-695-1980 Fax: 905-695-2078</p>	<p>Australia - Sydney Tel: 61-2-9868-6733</p> <p>China - Beijing Tel: 86-10-8569-7000</p> <p>China - Chengdu Tel: 86-28-8665-5511</p> <p>China - Chongqing Tel: 86-23-8980-9588</p> <p>China - Dongguan Tel: 86-769-8702-9880</p> <p>China - Guangzhou Tel: 86-20-8755-8029</p> <p>China - Hangzhou Tel: 86-571-8792-8115</p> <p>China - Hong Kong SAR Tel: 852-2943-5100</p> <p>China - Nanjing Tel: 86-25-8473-2460</p> <p>China - Qingdao Tel: 86-532-8502-7355</p> <p>China - Shanghai Tel: 86-21-3326-8000</p> <p>China - Shenyang Tel: 86-24-2334-2829</p> <p>China - Shenzhen Tel: 86-755-8864-2200</p> <p>China - Suzhou Tel: 86-186-6233-1526</p> <p>China - Wuhan Tel: 86-27-5980-5300</p> <p>China - Xian Tel: 86-29-8833-7252</p> <p>China - Xiamen Tel: 86-592-2388138</p> <p>China - Zhuhai Tel: 86-756-3210040</p>	<p>India - Bangalore Tel: 91-80-3090-4444</p> <p>India - New Delhi Tel: 91-11-4160-8631</p> <p>India - Pune Tel: 91-20-4121-0141</p> <p>Japan - Osaka Tel: 81-6-6152-7160</p> <p>Japan - Tokyo Tel: 81-3-6880-3770</p> <p>Korea - Daegu Tel: 82-53-744-4301</p> <p>Korea - Seoul Tel: 82-2-554-7200</p> <p>Malaysia - Kuala Lumpur Tel: 60-3-7651-7906</p> <p>Malaysia - Penang Tel: 60-4-227-8870</p> <p>Philippines - Manila Tel: 63-2-634-9065</p> <p>Singapore Tel: 65-6334-8870</p> <p>Taiwan - Hsin Chu Tel: 886-3-577-8366</p> <p>Taiwan - Kaohsiung Tel: 886-7-213-7830</p> <p>Taiwan - Taipei Tel: 886-2-2508-8600</p> <p>Thailand - Bangkok Tel: 66-2-694-1351</p> <p>Vietnam - Ho Chi Minh Tel: 84-28-5448-2100</p>	<p>Austria - Wels Tel: 43-7242-2244-39 Fax: 43-7242-2244-393</p> <p>Denmark - Copenhagen Tel: 45-4485-5910 Fax: 45-4485-2829</p> <p>Finland - Espoo Tel: 358-9-4520-820</p> <p>France - Paris Tel: 33-1-69-53-63-20 Fax: 33-1-69-30-90-79</p> <p>Germany - Garching Tel: 49-8931-9700</p> <p>Germany - Haan Tel: 49-2129-3766400</p> <p>Germany - Heilbronn Tel: 49-7131-72400</p> <p>Germany - Karlsruhe Tel: 49-721-625370</p> <p>Germany - Munich Tel: 49-89-627-144-0 Fax: 49-89-627-144-44</p> <p>Germany - Rosenheim Tel: 49-8031-354-560</p> <p>Israel - Ra'anana Tel: 972-9-744-7705</p> <p>Italy - Milan Tel: 39-0331-742611 Fax: 39-0331-466781</p> <p>Italy - Padova Tel: 39-049-7625286</p> <p>Netherlands - Drunen Tel: 31-416-690399 Fax: 31-416-690340</p> <p>Norway - Trondheim Tel: 47-72884388</p> <p>Poland - Warsaw Tel: 48-22-3325737</p> <p>Romania - Bucharest Tel: 40-21-407-87-50</p> <p>Spain - Madrid Tel: 34-91-708-08-90 Fax: 34-91-708-08-91</p> <p>Sweden - Gothenberg Tel: 46-31-704-60-40</p> <p>Sweden - Stockholm Tel: 46-8-5090-4654</p> <p>UK - Wokingham Tel: 44-118-921-5800 Fax: 44-118-921-5820</p>

Looking for pricing, stock, or lifecycle information?

Click below to explore more details on WIN SOURCE:

 [View PD70224ILQ on WIN SOURCE](#)

 [Microsemi Corporation](#) Information

Optimize Your Supply Chain with WIN SOURCE Solutions

-  Global Sourcing Solution
-  Obsolete Management
-  Cost Control Management
-  Shortage Management
-  Alternative Solution
-  Excess Inventory Management