

# W6100

## Hardwired Dual TCP/IP Stack Controller

V1.0.5



<http://www.wiznet.io/>

## W6100

W6100 is a hardwired Internet controller chip supporting IPv4/IPv6 dual stack by adding IPv6 functions on the basis of WIZnet's patented hardwired TCP/IP core technology. W6100 supports TCP/IP protocols such as TCP, UDP, IPv6, IPv4, ICMPv6, ICMPv4, IGMP, ARP and PPPoE. W6100 also includes 10Base-T / 10Base-Te / 100Base-TX Ethernet PHY and Ethernet MAC Controller which makes it suitable for embedded internet-enabled devices.

W6100 has 8 independent hardwired SOCKETs and supports various SOCKET-less commands, which are for IPv6 auto-configuration, monitoring, and managing the network via ARP, PINGv4, and PINGv6.

W6100 supports two kinds of HOST interfaces; SPI and parallel system BUS. It has 32KB internal memory for sending and receiving data. Designed for low power and low heat, W6100 provides WOL (Wake On LAN), Ethernet PHY power down mode and etc.

W6100 has two package types, 48 LQFP and 48 QFN lead-free. Both versions are PIN-2-PIN compatible with W5100S.

## Features

- Supports hardwired TCP/IP protocols  
: TCP, UDP, IPv6, IPv4, ICMPv6, ICMPv4, IGMP, MLDv1, ARP, PPPoE
- Supports IPv4/IPv6 dual stack
- Supports 8 independent SOCKETs simultaneously with 32KB memory
- Supports SOCKET-less commands  
: ARP, ICMPv6 (ARP, DAD, NA, RS) command for IPv6 auto-configuration & network monitoring (PING, PING6)
- Supports Ethernet PHY power down mode & system clock switching for power save
- Supports wake on LAN over UDP
- Supports serial & parallel HOST interface  
: High speed SPI (MODE 0/3), system BUS with 2 address signal & 8bit data
- Internal 32Kbytes memory for TX/ RX Buffers
- 10BaseT/ 10BaseTe / 100BaseTX Ethernet PHY integrated
- Supports auto negotiation (full/half duplex, 10 and 100-based)
- Supports auto-MDIX only on auto-negotiation mode
- Does not support IP fragmentation & jumbo packet
- 3V operation with 5V I/O signal tolerance
- Network indicator LEDs (full/half duplex, link, 10/100 speed, active)
- 48 Pin LQFP & QFN lead-free package (7x7mm, 0.5mm pitch)
- PIN-2-PIN compatible with W5100S

## Target Applications

W6100 can be used in various applications.

- Home network devices: set-top boxes, PVRs, digital media adapters
- Serial-to-Ethernet: access control, LED display, wireless AP relay
- Parallel-to-Ethernet: POS / mini printers, copy machine
- USB-to-Ethernet: storage devices, network printers
- GPIO-to-Ethernet: Home network sensors
- Security systems: DVR, network cameras, kiosks
- Factory & home automation
- Medical monitoring equipment
- Embedded servers
- Internet of Thing (IoT) devices
- IoT cloud devices
- Etc

## Block Diagram

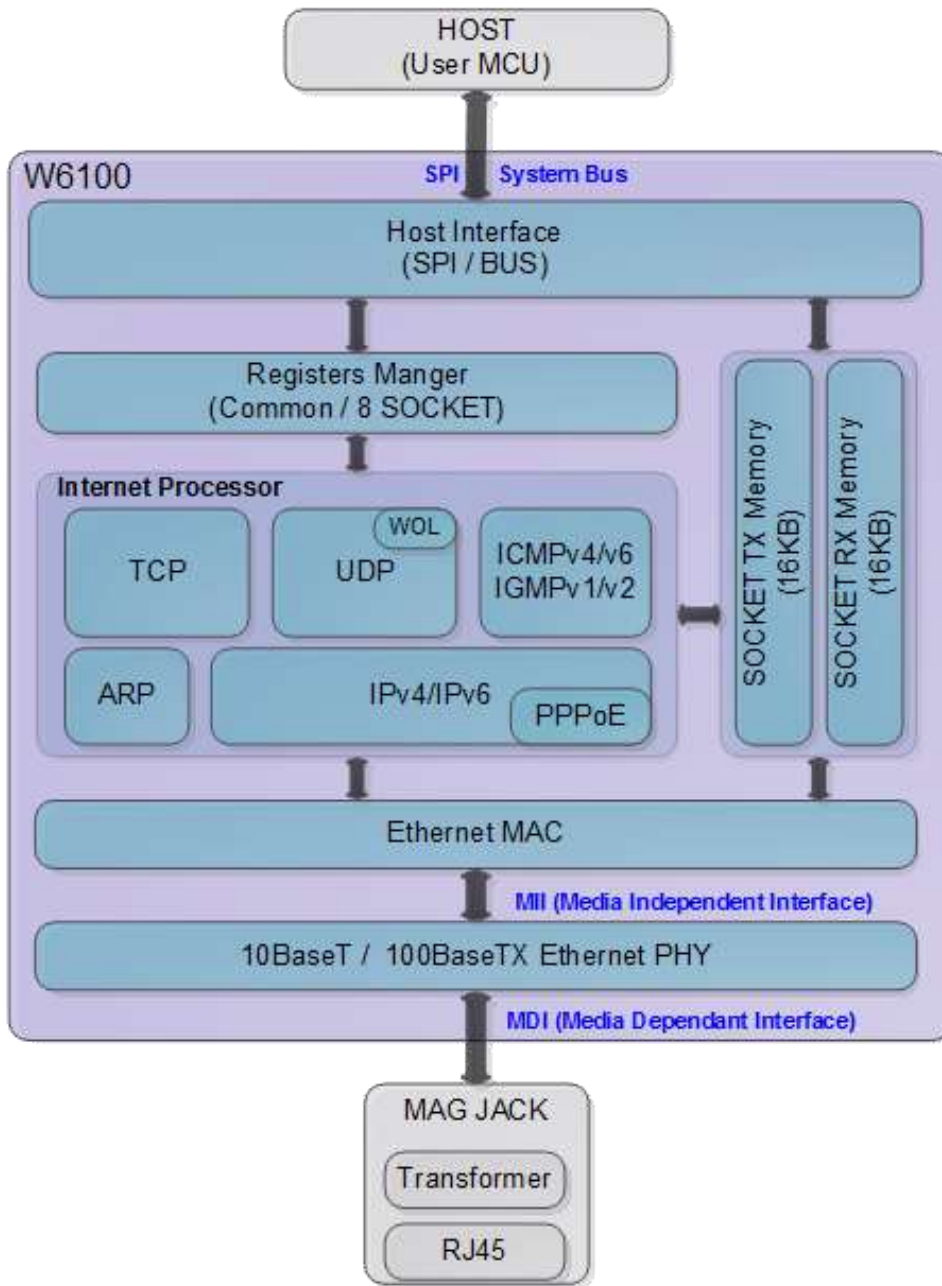

Figure 1 Block Diagram

---

# Contents

<b>1. PIN Description</b> .....	<b>12</b>
1.1    PIN Description .....	13
<b>2. Memory Map</b> .....	<b>17</b>
<b>3. W6100 Registers</b> .....	<b>19</b>
3.1    Common Register .....	19
3.2    SOCKET Register .....	25
<b>4. Register Descriptions</b> .....	<b>27</b>
4.1    Common Registers .....	28
4.1.1 CIDR (Chip Identification Register) .....	28
4.1.2 VER (Version Register) .....	28
4.1.3 SYSR (System Status Register) .....	28
4.1.4 SYCR0 (System Config Register 0) .....	29
4.1.5 SYCR1 (System Config Register 1) .....	30
4.1.6 TCNTR (Tick Counter Register) .....	30
4.1.7 TCNTRCLR (TCNTR Clear Register) .....	30
4.1.8 IR (Interrupt Register) .....	30
4.1.9 SIR (SOCKET Interrupt Register) .....	31
4.1.10 SLIR (SOCKET-less Interrupt Register) .....	32
4.1.11 IMR (Interrupt Mask Register) .....	33
4.1.12 IRCLR (IR Clear Register) .....	34
4.1.13 SIMR (SOCKET Interrupt Mask Register) .....	34
4.1.14 SLIMR (SOCKET-less Interrupt Mask Register) .....	34
4.1.15 SLIRCLR (SLIR Clear Register) .....	35
4.1.16 SLPSR (SOCKET-less Prefer Source IPv6 Address Register) .....	35
4.1.17 SLCR (SOCKET-less Command Register) .....	36
4.1.18 PHYSR (PHY Status Register) .....	37
4.1.19 PHYRAR (PHY Register Address Register) .....	37
4.1.20 PHYDIR (PHY Data Input Register) .....	38
4.1.21 PHYDOR (PHY Data Output Register) .....	38
4.1.22 PHYACR (PHY Access Control Register) .....	38
4.1.23 PHYDIVR (PHY Division Register) .....	38
4.1.24 PHYCR0 (PHY Control Register 0) .....	39
4.1.25 PHYCR1 (PHY Control Register 1) .....	39
4.1.26 NET4MR (Network IPv4 Mode Register) .....	40
4.1.27 NET6MR (Network IPv6 Mode Register) .....	41
4.1.28 NETMR (Network Mode Register) .....	42
4.1.29 NETMR2 (Network Mode Register 2) .....	43

---

4.1.30 PTMR (PPP Link Control Protocol Request Timer Register) .....	43
4.1.31 PMNR (PPP Link Control Protocol Magic number Register) .....	43
4.1.32 PHAR (PPPoE Server Hardware Address Register on PPPoE) .....	44
4.1.33 PSIDR (PPPoE Session ID Register on PPPoE) .....	44
4.1.34 PMRUR (PPPoE Maximum Receive Unit Register) .....	44
4.1.35 SHAR (Source Hardware Address Register) .....	44
4.1.36 GAR (Gateway IP Address Register) .....	45
4.1.37 SUBR (Subnet Mask Register) .....	45
4.1.38 SIPR (IPv4 Source Address Register) .....	45
4.1.39 LLAR (Link Local Address Register) .....	46
4.1.40 GUAR (Global Unicast Address Register) .....	46
4.1.41 SUB6R (IPv6 Subnet Prefix Register) .....	46
4.1.42 GA6R (IPv6 Gateway Address Register) .....	47
4.1.43 SLDIP6R (SOCKET-less Destination IPv6 Address Register) .....	47
4.1.44 SLDIPR (SOCKET-less Destination IPv4 Address Register) .....	47
4.1.45 SLDHAR (SOCKET-less Destination Hardware Address Register) .....	48
4.1.46 PINGIDR (PING ID Register) .....	48
4.1.47 PINGSEQR (PING Sequence-number Register) .....	48
4.1.48 UIPR (Unreachable IP Address Register) .....	49
4.1.49 UPORTR (Unreachable Port Register) .....	49
4.1.50 UIP6R (Unreachable IPv6 Address Register) .....	49
4.1.51 UPORT6R (Unreachable IPv6 Port Register) .....	49
4.1.52 INTPTMR (Interrupt Pending Time Register) .....	50
4.1.53 PLR (Prefix Length Register) .....	50
4.1.54 PFR (Prefix Flag Register) .....	50
4.1.55 VLTR (Valid Life Time Register) .....	50
4.1.56 PLTR (Preferred Life Time Register) .....	51
4.1.57 PAR (Prefix Address Register) .....	51
4.1.58 ICMP6BLKR (ICMPv6 Block Register) .....	51
4.1.59 CHPLCKR (Chip Lock Register) .....	52
4.1.60 NETLCKR (Network Lock Register) .....	52
4.1.61 PHYLCKR (PHY Lock Register) .....	52
4.1.62 RTR (Retransmission Time Register) .....	53
4.1.63 RCR (Retransmission Count Register) .....	53
4.1.64 SLRTR (SOCKET-less Retransmission Time Register) .....	53
4.1.65 SLRCR (SOCKET-less Retransmission Count Register) .....	54
4.1.66 SLHOPR (Hop limit Register) .....	54
4.2 SOCKET Register .....	55
4.2.1 Sn_MR (SOCKET n Mode Register) .....	55

---

4.2.2 Sn_PSR (SOCKET n Prefer Source IPv6 Address Register) .....	57
4.2.3 Sn_CR (SOCKET n Command Register) .....	57
4.2.4 Sn_IR (SOCKET n Interrupt Register) .....	60
4.2.5 Sn_IMR (SOCKET n Interrupt Mask Register).....	60
4.2.6 Sn_IRCLR (Sn_IR Clear Register) .....	61
4.2.7 Sn_SR (SOCKET n Status Register) .....	61
4.2.8 Sn_ESR (SOCKET n Extension Status Register) .....	62
4.2.9 Sn_PNR (SOCKET n IP Protocol Number Register) .....	63
4.2.10 Sn_TOSR (SOCKET n IP Type of Service Register) .....	63
4.2.11 Sn_TTLR (SOCKET n IP Time To Live Register) .....	63
4.2.12 Sn_FRGR (SOCKET n Fragment Offset in IP Header Register) .....	63
4.2.13 Sn_MSSR (SOCKET n Maximum Segment Size Register).....	64
4.2.14 Sn_PORTR (SOCKET n Source Port Register) .....	64
4.2.15 Sn_DHAR (SOCKET n Destination Hardware Address Register) .....	65
4.2.16 Sn_DIPR (SOCKET n Destination IPv4 Address Register) .....	65
4.2.17 Sn_DIP6R (SOCKET n Destination IPv6 Address Register) .....	65
4.2.18 Sn_DPORTR (SOCKET n Destination Port Register).....	66
4.2.19 Sn_MR2 (SOCKET n Mode register 2) .....	67
4.2.20 Sn_RTR (SOCKET n Retransmission Time Register) .....	68
4.2.21 Sn_RCR (SOCKET n Retransmission Count Register) .....	68
4.2.22 Sn_KPALVTR (SOCKET n Keep Alive Time Register).....	68
4.2.23 Sn_TX_BSR (SOCKET n TX Buffer Size Register) .....	68
4.2.24 Sn_TX_FSR (SOCKET n TX Free Buffer Size Register) .....	69
4.2.25 Sn_TX_RD (SOCKET n TX Read Pointer Register) .....	69
4.2.26 Sn_TX_WR (SOCKET n TX Write Pointer Register) .....	70
4.2.27 Sn_RX_BSR (SOCKET n RX Buffer Size Register) .....	70
4.2.28 Sn_RX_RSR (SOCKET n RX Received Size Register).....	70
4.2.29 Sn_RX_RD (SOCKET n RX Read Pointer Register).....	71
4.2.30 Sn_RX_WR (SOCKET n RX Write Pointer Register) .....	71
<b>5. HOST Interface Mode .....</b>	<b>72</b>
5.1 SPI Mode .....	72
5.1.1 SPI Frame .....	73
5.1.2 Variable Length Data Mode (VDM).....	76
5.1.3 Fixed Length Data Mode (FDM).....	77
5.2 Parallel BUS Mode .....	80
5.2.1 Parallel BUS Data Write .....	81
5.2.2 Parallel BUS Data Read.....	82
<b>6. Functional Description .....</b>	<b>83</b>
6.1 Initialization .....	83

---

6.1.1	Network Information Setting .....	83
6.1.2	SOCKET TX/RX Buffer Size Setting .....	84
6.2	TCP.....	85
6.2.1	TCP SERVER.....	86
6.2.2	TCP CLIENT .....	93
6.2.3	TCP DUAL .....	94
6.2.4	Other Functions .....	96
6.3	UDP.....	98
6.3.1	UDP Unicast.....	98
6.3.2	UDP Broadcast.....	102
6.3.3	UDP Multicast.....	104
6.3.4	UDP DUAL .....	106
6.3.5	Other Functions .....	108
6.4	IPRAW .....	109
6.4.1	Other Functions .....	114
6.5	MACRAW .....	115
6.6	SOCKET-less Command (SLCR).....	117
6.6.1	ARP117	
6.6.2	PING .....	119
6.6.3	ARP6 (ND, Neighbor Discovery) .....	121
6.6.4	PING6 (ICMPv6 Echo) .....	122
6.6.5	DAD (Duplicate Address Detection) .....	124
6.6.6	RS (Router Solicitation) .....	126
6.6.7	Unsolicited NA(Neighbor Advertisement).....	128
6.7	Retransmission.....	130
6.7.1	ARP & PING & ND Retransmission.....	130
6.7.2	TCP Retransmission.....	131
6.8	Others Functions .....	132
6.8.1	System Clock(SYS_CLK) Switching .....	132
6.8.2	Ethernet PHY Operation Mode Configuration .....	132
6.8.3	Ethernet PHY Parallel Detection.....	133
6.8.4	Ethernet PHY Auto MDIX .....	133
6.8.5	Ethernet PHY Power Down Mode .....	133
6.8.6	Ethernet PHY's Registers Control.....	135
6.8.7	Ethernet PHY 10BASE-Te Mode.....	137
<b>7.</b>	<b>Clock &amp; Transformer Requirements .....</b>	<b>138</b>
7.1	Quartz Crystal Requirements. ....	138
7.2	Oscillator requirements. ....	139
7.3	Transformer Characteristics.....	139

---

<b>8. Electrical Specification</b>	<b>140</b>
8.1 Absolute Maximum ratings	140
8.2 Absolute Maximum ratings (Electrical Sensitivity)	140
8.3 DC Characteristics	141
8.4 AC Characteristics	142
8.4.1 Reset Timing	142
8.4.2 BUS ACCESS TIMING	143
8.4.3 SPI ACCESS TIMING	144
8.4.4 Transformer Characteristics	145
8.4.5 MDIX	145
8.5 POWER DISSIPATION	145
<b>9. Package Information</b>	<b>146</b>
9.1 LQFP48	146
9.2 QFN48	148
<b>10. Document Revision History</b>	<b>149</b>

---

## List of Figures

Figure 1 Block Diagram .....	4
Figure 2 W6100 Pin Layout .....	12
Figure 3 W6100 Memory Map .....	17
Figure 4 State Diagram .....	62
Figure 5 Variable Length Data Mode (CSn controlled by HOST) .....	72
Figure 6 Fixed Length Data Mode (CSn is always connected by Ground) .....	72
Figure 7 SPI Mode 0 & Mode 3.....	73
Figure 8 SPI Frame Format .....	73
Figure 9 Write SPI Frame in VDM .....	76
Figure 10 Read SPI Frame in VDM .....	77
Figure 11 1 byte Data Write Access SPI Frame in FDM .....	78
Figure 12 2 bytes Data Write Access SPI Frame in FDM .....	78
Figure 13 4 bytes Data Write Access SPI Frame in FDM .....	78
Figure 14 1byte Data Read Access SPI Frame in FDM.....	79
Figure 15 2 bytes Data Read Access SPI Frame in FDM.....	79
Figure 16 4 bytes Data Read Access SPI Frame in FDM.....	79
Figure 17 HOST Interface in Parallel BUS Mode.....	80
Figure 18 Parallel BUS N-Bytes Data Write Access .....	81
Figure 19 Parallel Mode Continuous Read Access .....	82
Figure 20 TCP SERVER and TCP CLIENT .....	85
Figure 21 TCP SERVER Operation Flow .....	86
Figure 22 TCP CLIENT Operation Flow .....	93
Figure 23 UDP Operation Flow .....	98
Figure 24 Received DATA in UDP Mode SOCKET RX Buffer Block.....	99
Figure 25 IPv6 Multicast-Group Address Format.....	104
Figure 26 IPRAW Operation Flow .....	110
Figure 27 Received DATA in IPRAW4 Mode SOCKET RX Buffer Block .....	111
Figure 28 Received DATA in IPRAW6 Mode SOCKET RX Buffer Block .....	112
Figure 29 MACRAW Operation Flow .....	115
Figure 30 Received DATA Format in MACRAW .....	116
Figure 31 SOCKET-less Command Operation Flow .....	117
Figure 32 DAD Operation Flow.....	124
Figure 33 RS Operation Flow .....	126
Figure 34 Unsolicited NA Operation Flow.....	129
Figure 35 MDC/MDIO Write Control Flow.....	135
Figure 36 MDC/MDIO Read Control Flow .....	136
Figure 37 Quartz Crystal Model.....	138

---

Figure 38 Transformer Type.....	139
Figure 39 Reset Timing.....	142
Figure 40 BUS Read Timing .....	143
Figure 41 BUS Write Timing .....	143
Figure 42 SPI Access Timing.....	144
Figure 43 Transformer Type.....	145

## List of Tables

Table 1 Pin Type Notation .....	12
Table 2 PIN Description.....	13
Table 3 Parallel Mode Address Value .....	80
Table 4 Parameter Description in PACKET INFO.....	99
Table 5 Parameters of Flags in IPv6 Multicast Address.....	104
Table 6 Definition of Scope in IPv6 Multicast Address.....	104
Table 7 Internet Protocol supported in IPRAW Mode .....	109
Table 8 parameters of ‘PACKET INFO’ in IPRAW4 Mode.....	111
Table 9 parameters of ‘PACKET INFO’ in IPRAW6 Mode.....	112
Table 10 Quartz Crystal .....	138
Table 11 Crystal Recommendation Characteristics .....	138
Table 12 Oscillator Characteristics.....	139
Table 13 Transformer Characteristics .....	139
Table 14 Absolute Maximum ratings .....	140
Table 15 Electro Static Discharge (ESD).....	140
Table 16 Latch up Test .....	140
Table 17 DC Characteristics .....	141
Table 18 Reset Table .....	142
Table 19 BUS Read Timing .....	143
Table 20 BUS Write timing.....	144
Table 21 SPI Access Timing .....	144
Table 22 Transformer Characteristics .....	145
Table 23 Power Dissipation.....	145
Table 24 LQFP48 VARIATIONS (ALL DEMINIONS SHOWN IN MM) .....	146
Table 25 QFN48 VARIATIONS (ALL DEMINIONS SHOWN IN MM) .....	148

# 1. PIN Description

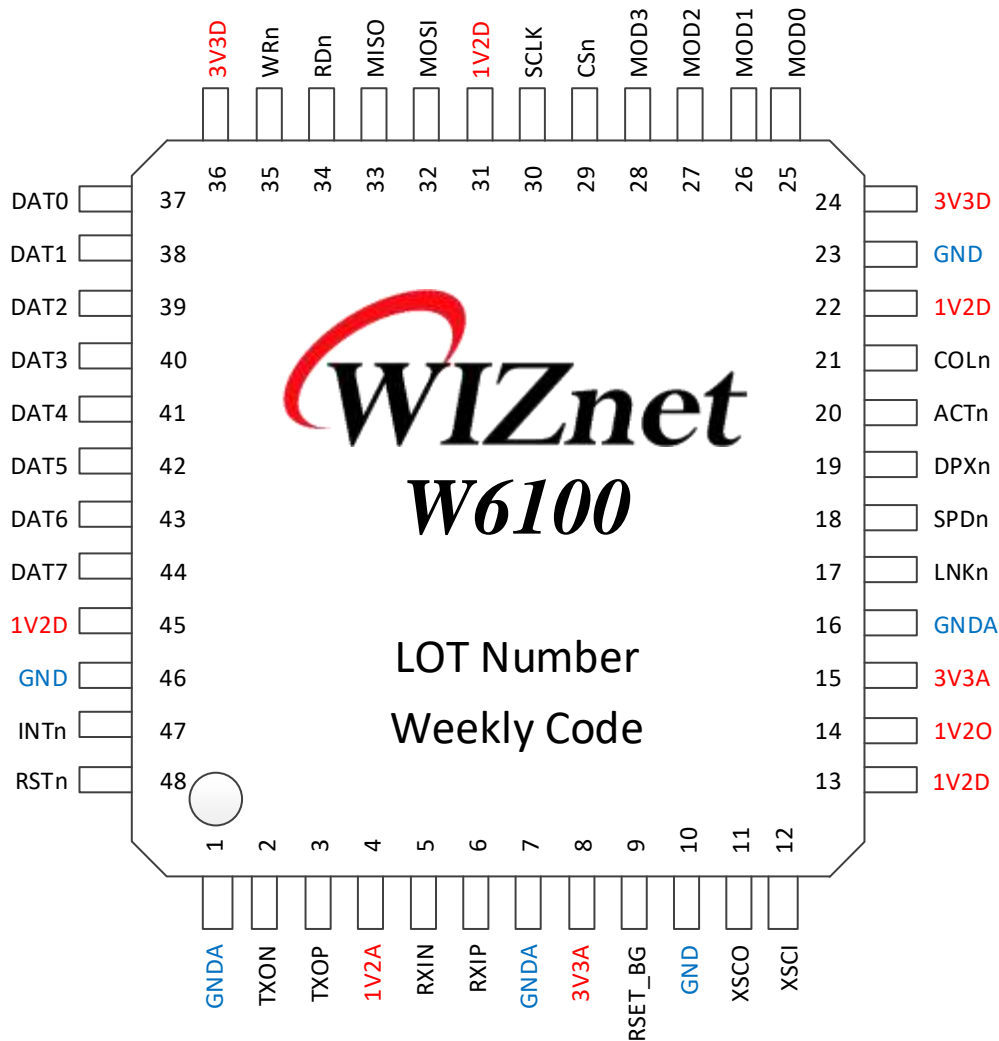

Figure 2 W6100 Pin Layout

Table 1 Pin Type Notation

Type	Description
I	Input
O	Output
M	Alternate (Multi-function) Signal
U	Internal pulled-up 75KΩ resistor
D	Internal pulled-down 75KΩ resistor
A	Analog
P	Power & Ground

## 1.1 PIN Description

Table 2 PIN Description

PIN #	Symbol	Type	Description
1	GND A	AP	<b>Analog Ground</b>
2	TXON	AO	<b>Differential Transmitted Signal Pair</b> Data is transmitted to Media in TXOP/TXON differential signal pair on MDI Mode.
3	TXOP	AO	
4	1V2A	AP	<b>Analog 1.2V Power</b> 1V20(PIN14) voltage source must be supplied back to this pin.
5	RXIN	AI	<b>Differential Received Signal Pair</b> Data is received from Media in RXIP/RXIN differential signal pair on MDI Mode.
6	RXIP	AI	
7	GND A	AP	<b>Analog Ground</b>
8	3V3A	AP	<b>Analog 3.3V Power</b>
9	RSET_BG	AO	<b>Off-chip Bias Resistor</b> Must be connected to Analog Ground through external 12.3K $\Omega$ , tolerance rate 1% Resistance.
10	GND	AP	<b>Digital Ground</b>
11	XSCO	AO	<b>25MHz Clock</b> Connect 25MHz Crystal Oscillator (XTAL) or Oscillator (OSC) for internal operation clock (SYS_CLK).  W6100 can convert it to 25MHz or 100MHz and uses the converted clock as SYS_CLK.
12	XSCI	AI	In normal mode, SYS_CLK is 100MHz. In low frequency mode, SYS_CLK is 25MHz  <b>* CAUTION</b> If OSC is used, 25MHz@1.2V must be used and only XSCI must be connected and XSCO must be floated.  ref) " <a href="#">Clock Selection Guide</a> ", same as W5100S
13	1V2D	P	<b>Digital 1.2V Power</b> 1V20 voltage source must be supplied to this pin.
14	1V2O	PO	<b>Internal Regulator 1.2V Power Output</b> Power which Internal Regulator of W6100 supplies. It supports Max 150mA.

			<p>Make sure to supply it to 1V2D and 1V2A through External Capacitor 3.3uF for stabilization.</p> <p>When 1V2O is supplied, 1V2D and 1V2A must be separated through Ferrite Bead.</p> <p><b>* CAUTION</b> This power is only for W6100. It must not be used for others device.</p>
15	3V3A	AP	<b>Analog 3.3V Power</b>
16	GND A	AP	<b>Analog Ground</b>
17	LNKn	OU	<p><b>Link Status LED</b></p> <p>It is valid in case of SPI and Parallel BUS Mode.</p> <p>Low: Link up High: Link down</p>
18	SPDn	OU	<p><b>Link Speed LED</b></p> <p>It is valid in case of SPI and Parallel BUS Mode.</p> <p>Low: 100Mbps High: 10Mbps</p>
19	DPXn	OU	<p><b>Link Duplex LED</b></p> <p>It is valid in case of SPI and Parallel BUS Mode.</p> <p>Low: Full-Duplex High: Half-Duplex</p>
20	ACTn	OU	<p><b>Link Activity LED</b></p> <p>It is valid in case of SPI and Parallel BUS Mode.</p> <p>Low: Link up state without TX/RX Blinking: Link up state with TX/RX data High: Link-down state</p>
21	COLn	OU	<p><b>Link Collision Detect LED</b></p> <p>It is valid in case of SPI and Parallel BUS Mode.</p> <p>It indicates a collision during Data transmission.</p> <p>Low: Collision Detected High: No Collision</p>
22	1V2D	P	<p><b>Digital 1.2V Power</b></p> <p>1V2O voltage source must be supplied to.</p>
23	GND	P	<b>Digital Ground</b>

24	3V3D	P	<b>Digital 3.3V power</b>
25	MOD[0]	ID	<b>W6100 Mode Selection</b>
26	MOD[1]	ID	Interface Mode is selected by MOD [3:0].
27	MOD[2]	ID	“000X” : SPI Mode
28	MOD[3]	ID	“010X” : Parallel BUS Mode Others : Reserved
29	CSn	IU	<b>W6100 Chip Select</b> Low: Select High: No Select
30	SCLK	ID	<b>SPI Clock</b> On SPI Mode, SPI Clock should be supplied. However, on Parallel BUS Mode, it must be connected to GND or be floated.
31	1V2D	P	<b>Digital 1.2V Power</b> 1V2O voltage source must be supplied.
32	MOSI /ADDR0	IDM	<b>SPI Master Output Slave Input / Address 0</b> On SPI Mode, it operates as MOSI. On Parallel BUS Mode, it is used as Address 0.
33	MISO /ADDR1	IOPM	<b>SPI Master Input Slave Output / Address 1</b> On SPI Mode, it operates as MISO. On Parallel BUS Mode, It is used to Address 1
34	RDn	IU	<b>Read Strobe</b> On Parallel BUS Mode, it indicates Read Operation On SPI Mode, it must be connected to 3V3D or be floated
35	WRn	IU	<b>Write Strobe</b> On Parallel BUS Mode, it indicates Write Operation. On SPI Mode, it must be connected to 3V3D or be floated
36	3V3D	P	<b>Digital 3.3V Power</b>
37	DAT0	IOU	<b>8 Bits Data BUS</b>  On Parallel BUS Mode, Data is carried over DAT [7:0] between HOST and W6100.  On SPI Mode, DAT [7:0] must be floated.
38	DAT1	IOU	
39	DAT2	IOU	
40	DAT3	IOU	
41	DAT4	IOU	
42	DAT5	IOU	
43	DAT6	IOU	
44	DAT7	IOU	
45	1V2D	P	<b>Digital 1.2V Power</b>
46	GND	P	<b>Digital Ground</b>
47	INTn	OP	<b>Interrupt</b>

			<p>When the event occurs during Ethernet communication, INTn is triggered.</p> <p>Lo : Interrupt Occurred High: No Interrupt</p> <p><i>ref) IEN(Interrupt Enable) in SYCR1(System Config Register1) , INTPTMR(Interrupt Pending Time Register), IR(Interrupt Register), SIR(SOCKET Interrupt Register), SLIR(SOCKET-less Interrupt Register)</i></p>
48	RSTn	IP	<p><b>Reset</b></p> <p>RSTn initializes W6100. RSTn must be asserted to Low for longer than 1.0us. After asserted RSTn, W5100S spends 60.3ms for initialization.</p> <p><i>ref) <a href="#">8.4.1 Reset Timing</a></i></p>

## 2. Memory Map

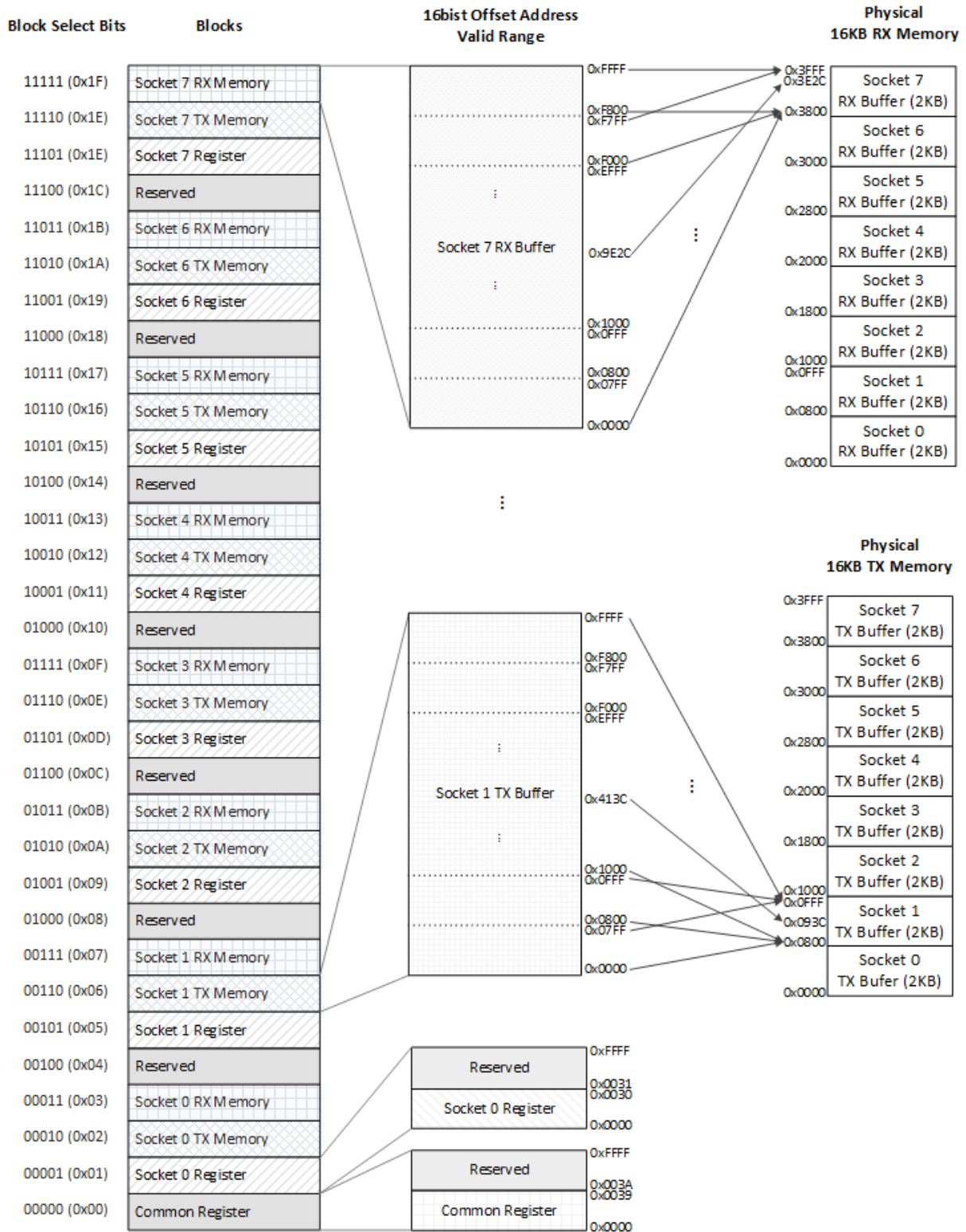

Figure 3 W6100 Memory Map

In Figure 3, W6100 consists the below blocks.

- 1 x Common Register Block, 7 x Reserved Block
- 8 x SOCKET n Register Block
- 8 x SOCKET n TX Buffer Block
- 8 x SOCKET n RX Buffer Block

These blocks are classified by block select 5bits. Each block is accessed with 16 bits offset address.

SOCKET n TX Buffer Blocks ( $0 \leq n \leq 7$ ) are initially allocated to 2KB each in 16KB TX memory. And each Block can be reallocated to 0, 1, 2, 4, 8, or 16KB through Sn\_TX\_BSR(4.2.23). The total allocated size of SOCKET n TX Buffer Blocks must not exceed 16KB.

SOCKET n RX Buffer Blocks ( $0 \leq n \leq 7$ ) are also initially allocated to 2KB each in 16KB RX memory. And each SOCKET n RX Buffer Block is reallocated in 0, 1, 2, 4, 8 or 16KB through Sn\_RX\_BSR(4.2.27). The total Size of allocated SOCKET n RX Buffer Block must not exceed 16KB.

### 3. W6100 Registers

#### 3.1 Common Register

Offset	Register	Type <sup>1</sup>	Reset
0x0000	CIDR0 (Chip Identification Register)	RO	0x61
0x0001	CIDR1	RO	0x00
0x0002	VER0 (Chip Version Register)	RO	0x46
0x0003	VER1	RO	0x61
0x2000	SYSR (System Status Register)	RO	0xEU
0x2004	SYCR0 (System Config Register 0)	WO	0x80
0x2005	SYCR1	R=W	0x80
0x2016	TCNTR0 (Tick Counter Register)	RO	0x00
0x2017	TCNTR1	RO	0x00
0x2020	TCNTCLR (TCNTR Clear Register)	WO	0x00
0x2100	IR (Interrupt Register)	RO	0x00
0x2101	SIR (SOCKET Interrupt Register)	RO	0x00
0x2102	SLIR (SOCKET-less Interrupt Register)	RO	0x00
0x2104	IMR (Interrupt Mask Register)	R=W	0x00
0x2108	IRCLR (IR Clear Register)	WO	0x00
0x2114	SIMR (SOCKET Interrupt Mask Register)	R=W	0x00
0x2124	SLIMR (SOCKET-less Interrupt Mask Register)	R=W	0x00
0x2128	SLIRCLR (SLIR Clear Register)	WO	0x00
0x212C	SLPSR (SOCKET-less Prefer Source IPv6 Address Register)	R=W	0x00
0x2130	SLCR (SOCKET-less Command Register)	RW,AC	0x00
0x3000	PHYSR (PHY Status Register)	RO	0x00
0x3008	PHYRAR (PHY Register Address Register)	R=W	0x00
0x300C	PHYDIR0 (PHY Data Input Register)	R=W	0x00
0x300D	PHYDIR1	R=W	0x00
0x3010	PHYDOR0 (PHY Data Output Register)	RO	0x00
0x3011	PHYDOR1	RO	0x00
0x3014	PHYACR (PHY Access Control Register)	RW,AC	0x00
0x3018	PHYDIVR (PHY Division Register)	R=W	0x01
0x301C	PHYCR0 (PHY Control Register 0)	WO	0x00
0x301D	PHYCR1	R=W	0x40
0x4000	NET4MR (Network IPv4 Mode Register)	R=W	0x00

<sup>1</sup> ref) 4. Register Descriptions

0x4004	NET6MR (Network IPv6 Mode Register)	R=W	0x00
0x4008	NETMR (Network Mode Register)	R=W	0x00
0x4009	NETMR2 (Network Mode Register 2)	R=W	0x00
0x4100	PTMR (PPP Link Control Protocol Request Timer Register)	R=W	0x28
0x4104	PMNR (PPP Link Control Protocol Magic number Register)	R=W	0x00
0x4108	PHAR0 (PPPoE Hardware Address Register on PPPoE)	R=W	0x00
0x4109	PHAR1	R=W	0x00
0x410A	PHAR2	R=W	0x00
0x410B	PHAR3	R=W	0x00
0x410C	PHAR4	R=W	0x00
0x410D	PHAR5	R=W	0x00
0x4110	PSIDR0 (PPPoE Session ID Register)	R=W	0x00
0x4111	PSIDR1	R=W	0x00
0x4114	PMRUR0 (PPPoE Maximum Receive Unit Register)	R=W	0xFF
0x4115	PMRUR1	R=W	0xFF
0x4120	SHAR0 (Source Hardware Address Register)	R=W	0x00
0x4121	SHAR1	R=W	0x00
0x4122	SHAR2	R=W	0x00
0x4123	SHAR3	R=W	0x00
0x4124	SHAR4	R=W	0x00
0x4125	SHAR5	R=W	0x00
0x4130	GAR0 (Gateway IP Address Register)	R=W	0x00
0x4131	GAR1	R=W	0x00
0x4132	GAR2	R=W	0x00
0x4133	GAR3	R=W	0x00
0x4134	SUBR0 (Subnet Mask Register)	R=W	0x00
0x4135	SUBR1	R=W	0x00
0x4136	SUBR2	R=W	0x00
0x4137	SUBR3	R=W	0x00
0x4138	SIPR0 (IPv4 Source Address Register)	R=W	0x00
0x4139	SIPR1	R=W	0x00
0x413A	SIPR2	R=W	0x00
0x413B	SIPR3	R=W	0x00
0x4140	LLAR0 (Link Local Address Register)	R=W	0x00
0x4141	LLAR1	R=W	0x00
0x4142	LLAR2	R=W	0x00
0x4143	LLAR3	R=W	0x00
0x4144	LLAR4	R=W	0x00

0x4145	LLAR5	R=W	0x00
0x4146	LLAR6	R=W	0x00
0x4147	LLAR7	R=W	0x00
0x4148	LLAR8	R=W	0x00
0x4149	LLAR9	R=W	0x00
0x414A	LLAR10	R=W	0x00
0x414B	LLAR11	R=W	0x00
0x414C	LLAR12	R=W	0x00
0x414D	LLAR13	R=W	0x00
0x414E	LLAR14	R=W	0x00
0x414F	LLAR15	R=W	0x00
0x4150	GUAR0 (Global Unicast Address Register)	R=W	0x00
0x4151	GUAR1	R=W	0x00
0x4152	GUAR2	R=W	0x00
0x4153	GUAR3	R=W	0x00
0x4154	GUAR4	R=W	0x00
0x4155	GUAR5	R=W	0x00
0x4156	GUAR6	R=W	0x00
0x4157	GUAR7	R=W	0x00
0x4158	GUAR8	R=W	0x00
0x4159	GUAR9	R=W	0x00
0x415A	GUAR10	R=W	0x00
0x415B	GUAR11	R=W	0x00
0x415C	GUAR12	R=W	0x00
0x415D	GUAR13	R=W	0x00
0x415E	GUAR14	R=W	0x00
0x415F	GUAR15	R=W	0x00
0x4160	SUB6R0 (IPv6 Subnet Prefix Register)	R=W	0x00
0x4161	SUB6R1	R=W	0x00
0x4162	SUB6R2	R=W	0x00
0x4163	SUB6R3	R=W	0x00
0x4164	SUB6R4	R=W	0x00
0x4165	SUB6R5	R=W	0x00
0x4166	SUB6R6	R=W	0x00
0x4167	SUB6R7	R=W	0x00
0x4168	SUB6R8	R=W	0x00
0x4169	SUB6R9	R=W	0x00
0x416A	SUB6R10	R=W	0x00

0x416B	SUB6R11	R=W	0x00
0x416C	SUB6R12	R=W	0x00
0x416D	SUB6R13	R=W	0x00
0x416E	SUB6R14	R=W	0x00
0x416F	SUB6R15	R=W	0x00
0x4170	GA6R0 (IPv6 Gateway Address Register)	R=W	0x00
0x4171	GA6R1	R=W	0x00
0x4172	GA6R2	R=W	0x00
0x4173	GA6R3	R=W	0x00
0x4174	GA6R4	R=W	0x00
0x4175	GA6R5	R=W	0x00
0x4176	GA6R6	R=W	0x00
0x4177	GA6R7	R=W	0x00
0x4178	GA6R8	R=W	0x00
0x4179	GA6R9	R=W	0x00
0x417A	GA6R10	R=W	0x00
0x417B	GA6R11	R=W	0x00
0x417C	GA6R12	R=W	0x00
0x417D	GA6R13	R=W	0x00
0x417E	GA6R14	R=W	0x00
0x417F	GA6R15	R=W	0x00
0x4180	SLDIP6R0 (SOCKET-less Destination IP Address Register)	R=W	0x00
0x4181	SLDIP6R1	R=W	0x00
0x4182	SLDIP6R2	R=W	0x00
0x4183	SLDIP6R3	R=W	0x00
0x4184	SLDIP6R4	R=W	0x00
0x4185	SLDIP6R5	R=W	0x00
0x4186	SLDIP6R6	R=W	0x00
0x4187	SLDIP6R7	R=W	0x00
0x4188	SLDIP6R8	R=W	0x00
0x4189	SLDIP6R9	R=W	0x00
0x418A	SLDIP6R10	R=W	0x00
0x418B	SLDIP6R11	R=W	0x00
0x418C	SLDIP6R12	R=W	0x00
0x418D	SLDIP6R13	R=W	0x00
0x418E	SLDIP6R14	R=W	0x00
0x418F	SLDIP6R15	R=W	0x00

0x4190	SLDHAR0 (SOCKET-less Destination Hardware Address Register)	RO	0x00
0x4191	SLDHAR1	RO	0x00
0x4192	SLDHAR2	RO	0x00
0x4193	SLDHAR3	RO	0x00
0x4194	SLDHAR4	RO	0x00
0x4195	SLDHAR5	RO	0x00
0x4198	PINGIDR0 (PING ID Register)	R=W	0x00
0x4199	PINGIDR1	R=W	0x00
0x419C	PINGSEQR0 (PING Sequence-number Register)	R=W	0x00
0x419D	PINGSEQR1	R=W	0x00
0x41A0	UIPR0 (Unreachable IP Address Register)	RO	0x00
0x41A1	UIPR1	RO	0x00
0x41A2	UIPR2	RO	0x00
0x41A3	UIPR3	RO	0x00
0x41A4	UPORTR0 (Unreachable Port Register)	RO	0x00
0x41A5	UPORTR1	RO	0x00
0x41B0	UIP6R0 (Unreachable IPv6 Address Register)	RO	0x00
0x41B1	UIP6R1	RO	0x00
0x41B2	UIP6R2	RO	0x00
0x41B3	UIP6R3	RO	0x00
0x41B4	UIP6R4	RO	0x00
0x41B5	UIP6R5	RO	0x00
0x41B6	UIP6R6	RO	0x00
0x41B7	UIP6R7	RO	0x00
0x41B8	UIP6R8	RO	0x00
0x41B9	UIP6R9	RO	0x00
0x41BA	UIP6R10	RO	0x00
0x41BB	UIP6R11	RO	0x00
0x41BC	UIP6R12	RO	0x00
0x41BD	UIP6R13	RO	0x00
0x41BE	UIP6R14	RO	0x00
0x41BF	UIP6R15	RO	0x00
0x41C0	UPORT6R0 (Unreachable IPv6 Port Register)	RO	0x00
0x41C1	UPORT6R1	RO	0x00
0x41C5	INTPTMR0 (Interrupt Pending Time Register)	R=W	0x00
0x41C6	INTPTMR1	R=W	0x00
0x41D0	PLR (Prefix Length Register)	RO	0x00

0x41D4	PFR (Prefix Flag Register)	RO	0x00
0x41D8	VLTR0 (Valid Life Time Register)	RO	0x00
0x41D9	VLTR1	RO	0x00
0x41DA	VLTR2	RO	0x00
0x41DB	VLTR3	RO	0x00
0x41DC	PLTR0 (Preferred Life Time Register)	RO	0x00
0x41DD	PLTR1	RO	0x00
0x41DE	PLTR2	RO	0x00
0x41DF	PLTR3	RO	0x00
0x41E0	PAR0 (Prefix Address Register)	RO	0x00
0x41E1	PAR1	RO	0x00
0x41E2	PAR2	RO	0x00
0x41E3	PAR3	RO	0x00
0x41E4	PAR4	RO	0x00
0x41E5	PAR5	RO	0x00
0x41E6	PAR6	RO	0x00
0x41E7	PAR7	RO	0x00
0x41E8	PAR8	RO	0x00
0x41E9	PAR9	RO	0x00
0x41EA	PAR10	RO	0x00
0x41EB	PAR11	RO	0x00
0x41EC	PAR12	RO	0x00
0x41ED	PAR13	RO	0x00
0x41EE	PAR14	RO	0x00
0x41EF	PAR15	RO	0x00
0x41F0	ICMP6BLKR (ICMPv6 Block Register)	R=W	0x00
0x41F4	CHPLCKR (Chip Lock Register)	WO	0x00
0x41F5	NETLCKR (Network Lock Register)	WO	0x00
0x41F6	PHYLCKR (PHY Lock Register)	WO	0x00
0x4200	RTR0 (Retransmission Time Register)	R=W	0x07
0x4201	RTR1	R=W	0xD0
0x4204	RCR (Retransmission Count Register)	R=W	0x08
0x4208	SLRTR0 (SOCKET-less Retransmission Time Register)	R=W	0x07
0x4209	SLRTR1	R=W	0xD0
0x420C	SLRCR (SOCKET-less Retransmission Count Register)	R=W	0x00
0x420F	SLHOPR (Hop limit Register)	R=W	0x80

## 3.2 SOCKET Register

Offset	Register	Type	Reset
0x0000	Sn_MR (SOCKET n Mode Register)	R=W	0x00
0x0004	Sn_PSR (SOCKET n Prefer Source IPv6 Address Register)	R=W	0x00
0x0010	Sn_CR (SOCKET n Command Register)	RW,AC	0x00
0x0020	Sn_IR (SOCKET n Interrupt Register)	WO	0x00
0x0024	Sn_IMR (SOCKET n Interrupt Mask Register)	R=W	0xFF
0x0028	Sn_IRCLR (Sn_IR Clear Register)	WO	0xFF
0x0030	Sn_SR (SOCKET n Status Register)	RO	0x00
0x0031	Sn_ESR (SOCKET n Extension Status Register)	RO	0x00
0x0100	Sn_PNR (SOCKET n IP Protocol Number Register)	R=W	0x00
0x0104	Sn_TOSR (SOCKET n IP Type Of Service Register)	R=W	0x00
0x0108	Sn_TTLR (SOCKET n IP Time To Live Register)	R=W	0x80
0x010C	Sn_FRGR0 (SOCKET n Fragment Offset in IP Header Register)	R=W	0x40
0x010D	Sn_FRGR1	R=W	0x00
0x0110	Sn_MSSR0 (SOCKET n Maximum Segment Size Register)	RW	0x00
0x0111	Sn_MSSR1	RW	0x00
0x0114	Sn_PORTR0 (SOCKET n Source Port Register)	R=W	0x00
0x0115	Sn_PORTR1	R=W	0x00
0x0118	Sn_DHAR0 (SOCKET n Destination Hardware Address Register)	RW	0x00
0x0119	Sn_DHAR1	RW	0x00
0x011A	Sn_DHAR2	RW	0x00
0x011B	Sn_DHAR3	RW	0x00
0x011C	Sn_DHAR4	RW	0x00
0x011D	Sn_DHAR5	RW	0x00
0x0120	Sn_DIPR0 (SOCKET n Destination IPv4 Address Register)	RW	0x00
0x0121	Sn_DIPR1	RW	0x00
0x0122	Sn_DIPR2	RW	0x00
0x0123	Sn_DIPR3	RW	0x00
0x0130	Sn_DIP6R0 (SOCKET n Destination IPv6 Address Register)	RW	0x00
0x0131	Sn_DIP6R1	RW	0x00
0x0132	Sn_DIP6R2	RW	0x00
0x0133	Sn_DIP6R3	RW	0x00
0x0134	Sn_DIP6R4	RW	0x00
0x0135	Sn_DIP6R5	RW	0x00
0x0136	Sn_DIP6R6	RW	0x00
0x0137	Sn_DIP6R7	RW	0x00

0x0138	Sn_DIP6R8	RW	0x00
0x0139	Sn_DIP6R9	RW	0x00
0x013A	Sn_DIP6R10	RW	0x00
0x013B	Sn_DIP6R11	RW	0x00
0x013C	Sn_DIP6R12	RW	0x00
0x013D	Sn_DIP6R13	RW	0x00
0x013E	Sn_DIP6R14	RW	0x00
0x013F	Sn_DIP6R15	RW	0x00
0x0140	Sn_DPORTR0 (SOCKET n Destination Port Register)	RW	0x00
0x0141	Sn_DPORTR1	RW	0x00
0x0144	Sn_MR2 (SOCKET n Mode Register 2)	R=W	0x00
0x0180	Sn_RTR0 (SOCKET n Retransmission Time Register)	RW	0x00
0x0181	Sn_RTR1	RW	0x00
0x0184	Sn_RCR (SOCKET n Retransmission Count Register)	RW	0x00
0x0188	Sn_KPALVTR (SOCKET n Keep Alive Time Register)	R=W	0x00
0x0200	Sn_TX_BSR (SOCKET n TX Buffer Size Register)	R=W	0x02
0x0204	Sn_TX_FSR0 (SOCKET n TX Free Size Register)	RO	0x00
0x0205	Sn_TX_FSR1	RO	0x00
0x0208	Sn_TX_RD0 (SOCKET n TX Read Pointer Register)	RO	0x00
0x0209	Sn_TX_RD1	RO	0x00
0x020C	Sn_TX_WR0 (SOCKET n TX Write Pointer Register)	RW	0x00
0x020D	Sn_TX_WR1	RW	0x00
0x0220	Sn_RX_BSR (SOCKET n RX Buffer Size Register)	R=W	0x02
0x0224	Sn_RX_RSR0 (SOCKET n RX Received Size Register)	RO	0x00
0x0225	Sn_RX_RSR1	RO	0x00
0x0228	Sn_RX_RD0 (SOCKET n RX Read Pointer Register)	RW	0x00
0x0229	Sn_RX_RD1	RW	0x00
0x022C	Sn_RX_WR0 (SOCKET n RX Write Pointer Register)	RO	0x00
0x022D	Sn_RX_WR1	RO	0x00

## 4. Register Descriptions

### Register Notation

* Register Symbol (Register full Name)							
- [Register Type, Register Type, ...][Address Offset][Reset Value]							
Register Description....							
7	6	5	4	3	2	1	0
Bit7	Bit6	Bit5	Bit4	Bit3	Bit2	Bit1	Bit0
Bit Type	Bit Type	Bit Type	Bit Type	Bit Type	Bit Type	Bit Type	Bit Type
Ex) Sn_IR[3:0] denotes Register Symbol[Upper bit : Lower bit].							
Sn_IR[3:0] = "0001" is meaning Sn_IR[3]='0', Sn_IR[2]='0', Sn_IR[1]='0' and Sn_IR[0]='1'							

### [Register/bit Type]: Type of Register.

- [RW : Register / bit available to Read and Write Both
- [R=W]: Register / bit which written value and the read value are the same.
- [RO]: Read Only Register/bit
- [WO]: Write Only Register/bit
- [W]: Write Only Register/bit
- [WC]: Register/Bit to be clear by writing '1'
- [W0]: Register/Bit which only '0' can be written
- [W1]: Register/bit which only '1' can be written
- [AC]: Auto Clear Register/bit
- [1]: Always read '1'
- [0]: Always read '0'
- [-]: Not available

### [Address Offset]: The address offset of the register

### [Reset Value]: Default Value.

Ex1) 4.1.28 NETMR (Network Mode Register)

**[R=W][0x4008][0x00]**

NETMR sets all kinds of block mode and WOL.

7	6	5	4	3	2	1	0
-	-	ANB	M6B		WOL	IP6B	IP4B
		R=W	R=W		R=W	R=W	R=W

Ex2) NETMR[ANB]

ANB bit of NETMR

Ex3) NETMR[7:0]

From 7<sup>th</sup> bit to 0<sup>th</sup> bit of NETMR

## 4.1 Common Registers

### 4.1.1 CIDR (Chip Identification Register)

**[RO][0x0000-0x0001] [0x6100]**

CHIP ID is 0x6100 and fixed.

CIDR0(0x0000)	CIDR1(0x0001)
0x61	0x00

### 4.1.2 VER (Version Register)

**[RO][0x0002-0x0003] [0x4661]**

Version is 0x4661.

VER0(0x0002)	VER1(0x0003)
0x46	0x61

### 4.1.3 SYSR (System Status Register)

**[RO][0x2000] [0xEU]**

It shows the status of CHIP/NET/PHY configuration lock and HOST interface mode.

7	6	5	4	3	2	1	0
CHPL	NETL	PHYL	-	-	-	IND	SPI
RO	RO	RO				RO	RO

Bit	Symbol	Description						
7	CHPL	<p><b>CHIP Lock Status</b>            CHIP Lock is set by CHPLCKR(Chip Configuration Lock Register).</p> <p>0: Unlock - possible to set SYCOR &amp; SYC1R            1: Lock - unable to set SYCOR &amp; SYC1R</p>						
6	NETL	<p><b>NET Lock Status</b>            NET Lock is set by NETLCKR(Network Configuration Lock Register)</p> <p>0: Unlock - possible to set Network Configuration Registers            1: Lock - unable to set Network Configuration Registers</p> <p><i>ref) Network Configuration Registers to be locked by NETL</i></p> <table border="1" data-bbox="571 1951 1283 2042"> <thead> <tr> <th>IPv4</th> <th>SHAR</th> <th>Source Hardware Address Register</th> </tr> </thead> <tbody> <tr> <td></td> <th>GAR</th> <th>Gateway IP Address Register</th> </tr> </tbody> </table>	IPv4	SHAR	Source Hardware Address Register		GAR	Gateway IP Address Register
IPv4	SHAR	Source Hardware Address Register						
	GAR	Gateway IP Address Register						

				SUBR	Subnet Mask Register
				SIPR	Source IP Address Register
		IPv6		LLAR	Link Local Address Register
				GUAR	Global Unicast Address Register
				SUB6R	IPv6 Subnet Prefix Register
				GA6R	IPv6 Gateway IP Address It is excluded from lock mechanism
		<p><b>* CAUTION : GA6R can be set regardless of setting of NETL.</b></p>			
5	PHYL	<p><b>PHY Lock Status</b> PHY Lock can be set by PHYLCKR(PHY Configuration Lock Register).  0: Unlock - possible to set PHYCOR, PHYC1R 1: Lock - unable to set PHY Control Register (PHYCOR, PHYC1R)</p>			
[4:2]	-	Reserved			
1	IND	<p><b>Parallel BUS Interface Mode</b> 0: Others 1: PIN MODE[3:0] = "010X"</p>			
0	SPI	<p><b>SPI Interface Mode</b> 0: Others 1: PIN MODE[3:0] = "000X"</p>			

#### 4.1.4 SYCR0 (System Config Register 0)

**[WO][0x2004] [0x80]**

SYCR0 softly resets to W6100

SYCR0 can be set in case of only SYSR[CHPL] = '0' .

	7	6	5	4	3	2	1	0
RST	-	-	-	-	-	-	-	-
WO								

Bit	Symbol	Description
7	RST	<p><b>Software Reset</b> W6100 S/W reset. All registers are initialized.  0 : W6100 reset 1 : Normal operation</p>
[6:0]	-	Reserved

### 4.1.5 SYCR1 (System Config Register 1)

*[R=W][0x2005] [0x80]*

Interrupt enable and system operation clock (SYS\_CLK) can be set by this register.

7	6	5	4	3	2	1	0
IEN	-	-	-	-	-	-	CLKSEL
R=W							R=W

Bit	Symbol	Description
7	IEN	<b>Interrupt Enable</b> It makes Interrupt enable.  0 : Disable - INTn is always High. 1 : Enable - When the event occurs, INTn goes low.
[6:1]	-	Reserved
0	CLKSEL	<b>System Operation Clock Select</b> In case of SYSR[CHPL] = '0', Select SYS_CLK.  0 : 100MHz 1 : 25MHz

### 4.1.6 TCNTR (Tick Counter Register)

*[RO][0x2016-0x2017][0x0000]*

It is automatically increased every 100us.

### 4.1.7 TCNTRCLR (TCNTR Clear Register)

*[WO][0x2020][0x00]*

With Write operation to TCNTRCLR, TCNTR counter value is initialized.

### 4.1.8 IR (Interrupt Register)

*[RO] [0x2100] [0x00]*

When an event such as WOL (Wake On LAN) or destination unreachable occurs, the corresponding bit of IR is set to 1.

7	6	5	4	3	2	1	0
WOL			UNR6		IPCONF	UNR4	PTERM
RO			RO		RO	RO	RO

Bit	Symbol	Description
7	WOL	<b>WOL(Wake On LAN) Magic Packet</b> 0 : Others 1 : WOL MAGIC Packet received
[6:5]	-	Reserved
4	UNR6	<b>Destination IPv6 Port Unreachable</b> 0 : Others 1 : ICMPv6 Destination Port Unreachable Packet received  <i>ref) The Unreachable IPv6 Address and the Port Number of the received Unreachable Packet are stored in <a href="#">UIP6R (Unreachable IPv6 Address Register)</a> and <a href="#">UPORT6R (Unreachable IPv6 Port Register)</a>, respectively.</i>
3	-	Reserved
2	IPCONF	<b>IP Conflict</b> 0 : Others 1 : IPv4 Address Conflict occurred
1	UNR4	<b>Destination Port Unreachable</b> 0: Others 1: ICMPv4 Destination Port Unreachable Packet received  <i>ref) The Unreachable IP Address and Port Number of the received Unreachable Packet are stored in <a href="#">UIPR (Unreachable IP Address Register)</a> and <a href="#">UPORTR (Unreachable Port Register)</a>, respectively.</i>
0	PTERM	<b>PPPoE Terminated</b> 0 : Others 1 : a PPPoE connection was terminated by receiving PPPT or LCPT packets

#### 4.1.9 SIR (SOCKET Interrupt Register)

**[RO] [0x2101] [0x00]**

When the IR of a specific SOCKET is not '0', corresponding bit is set to '1'.

7	6	5	4	3	2	1	0
S7_INT	S6_INT	S5_INT	S4_INT	S3_INT	S2_INT	S1_INT	S0_INT
RO	RO	RO	RO	RO	RO	RO	RO

Bit	Symbol	Description
[7:0]	Sn_INT-	<b>SOCKET n Interrupt</b>

0 : when Sn\_IR is '0'  
1 : when Sn\_IR is not '0'

#### 4.1.10 SLIR (SOCKET-less Interrupt Register)

**[RO] [0x2102] [0x00]**

When a specific command of the SLCR (SOCKET-less Command Register) is successfully executed, timeout occurs for the executed command, or an ICMPv6 RA packet is received from the IPv6 Gateway (Router), the corresponding bit is set.

7	6	5	4	3	2	1	0
TOUT	ARP4	PING4	ARP6	PING6	NS	RS	RA
RO	RO	RO	RO	RO	RO	RO	RO

Bit	Symbol	Description
7	TOUT	<b>Timeout Interrupt</b> 0 : Others 1 : When TIMEOUT occurs after any SOCKET-less Command
6	ARP4	<b>ARP Interrupt</b> 0 : Others 1 : When ARP Reply received after SOCKET-less ARP command
5	PING4	<b>PING Interrupt</b> 0 : Others 1 : When PING Reply received after SOCKET-less PING command
4	ARP6	<b>IPv6 ARP Interrupt</b> 0 : Others 1 : When ARP6 Reply received after SOCKET-less ARP6 command
3	PING6	<b>IPv6 PING Interrupt</b> 0 : Others 1 : When PING6 Reply received after SOCKET-less PING6 command
2	NS	<b>DAD NS Interrupt</b> 0 : Others 1 : When NA received after SOCKET-less NS command <i>ref) NS bit is used for IPv6 Address Conflicition Detection.</i>
1	RS	<b>Auto configuration RS Interrupt</b> 0 : Others 1 : When RA received after SOCKET-less RS command
0	RA	<b>RA Receive Interrupt</b> 0 : Others 1 : When All-node RA received from IPv6 Gateway

When SLIR [RS] = '1' or SLIR [RA] = '1', a prefix information of RA Packet is stored to corresponding registers as follows and can be used for IPv6 Auto-configuration.

- PLR (Prefix Length Register)
- PFR (Prefix Flag Register)
- VLTR (RA Valid Life Time Register)
- PLTR (RA Preferred Life Time Register)
- PAR (Prefix Address Register)

**\* CAUTION:** Only when the first option of received RA message is source link-layer address(0x01) and the second option is prefix information Option (0x03), the above registers are correct set. Otherwise, it can receive the RA message using the IPRAW6 Mode SOCKET and process the prefix information.

#### 4.1.11 IMR (Interrupt Mask Register)

[R=W] [0x2104] [0x00]

IMR is for masking the corresponding interrupts to be enabled or disabled.

7	6	5	4	3	2	1	0
WOL			UNR6		IPCONF	UNR4	PTERM
R=W			R=W		R=W	R=W	R=W

Bit	Symbol	Description
7	WOL	<b>WOL(Wake On LAN) Magic Packet Interrupt Mask</b> 0 : Disable WOL Interrupt 1 : Enable WOL Interrupt
[6:5]	-	Reserved
4	UNR6	<b>Destination Port Unreachable IPv6 Interrupt Mask</b> 0 : Disable UNREACH6 Interrupt 1 : Enable UNREACH6 Interrupt
3	-	Reserved
2	IPCONF	<b>IPv4 Conflict Interrupt Mask</b> 1 : Enable CONFLICT Interrupt 0 : Disable CONFLICT Interrupt
1	UNR4	<b>Destination Port Unreachable Interrupt Mask</b> 1 : Enable UNREACH Interrupt 0 : Disable UNREACH Interrupt
0	PTERM	<b>PPPoE Terminated Interrupt Mask</b> 1 : Enable PPPTERM Interrupt 0 : Disable PPPTERM Interrupt

#### 4.1.12 IRCLR (IR Clear Register)

**[W1] [0x2108] [0x00]**

When the IRCLR bit corresponding to a specific bit of IR is written as '1', IR bit is cleared.

7	6	5	4	3	2	1	0
WOL			UNR6		IPCONF	UNR4	PTERM
W1			W1		W1	W1	W1

#### 4.1.13 SIMR (SOCKET Interrupt Mask Register)

**[R=W] [0x2114] [0x00]**

SIMR masks bit corresponding in SIR.

7	6	5	4	3	2	1	0
S7_INT	S6_INT	S5_INT	S4_INT	S3_INT	S2_INT	S1_INT	S0_INT
R=W	R=W	R=W	R=W	R=W	R=W	R=W	R=W

Bit	Symbol	Description
[7:0]	Sn_INT	<b>SOCKET n Interrupt Mask</b> 1 : Enable SOCKET n Interrupt 0 : Disable SOCKET n Interrupt

#### 4.1.14 SLIMR (SOCKET-less Interrupt Mask Register)

**[R=W] [0x2124] [0x00]**

SIMR masks bit corresponding in SLIR.

7	6	5	4	3	2	1	0
TOUT	ARP4	PING4	ARP6	PING6	NS	RS	RA
R=W	R=W	R=W	R=W	R=W	R=W	R=W	R=W

Bit	Symbol	Description
7	TOUT	<b>TIMEOUT Interrupt Mask</b> 1 : Enable TIMEOUT Interrupt 0 : Disable TIMEOUT Interrupt
6	ARP4	<b>ARP Interrupt Mask</b> 1 : Enable ARP4 Interrupt 0 : Disable ARP4 Interrupt
5	PING4	<b>PING Interrupt Mask</b> 1 : Enable PING4 Interrupt

		0 : Disable PING4 Interrupt
4	ARP6	<b>IPv6 ARP Interrupt Mask</b> 1 : Enable ARPv6 Interrupt 0 : Disable ARPv6 Interrupt
3	PING6	<b>IPv6 PING Interrupt Mask</b> 1 : Enable PINGv6 Interrupt 0 : Disable PINGv6 Interrupt
2	NS	<b>DAD NS Interrupt Mask</b> 1 : Enable DAD NS Interrupt 0 : Disable DAD NS Interrupt
1	RS	<b>Auto configuration RS Interrupt Mask</b> 1 : Enable AUTO RS Interrupt 0 : Disable AUTO RS Interrupt
0	RA	<b>RA Receive Interrupt Mask</b> 1 : Enable RA RECV Interrupt 0 : Disable RA RECV Interrupt

#### 4.1.15 SLIRCLR (SLIR Clear Register)

**[W1] [0x2128] [0x00]**

When the SLIRCLR bit corresponding to a specific bit of SLIR is written as '1', SLIR bit is cleared.

7	6	5	4	3	2	1	0
TOUT	ARP4	PING4	ARP6	PING6	NS	RS	RA
W1	W1	W1	W1	W1	W1	W1	W1

#### 4.1.16 SLPSR (SOCKET-less Prefer Source IPv6 Address Register)

**[R=W] [0x212C] [0x00]**

SLPSR sets the source address of the IPv6 packet to be transmitted by the SLCR (SOCKET-less Command Register).

Value	Symbol	Description
0x00	AUTO	Select the source IPv6 address (SIP6) according to the destination IPv6 Address (SLDIP6R: SOCKET-less Destination IPv6 Address Register)  If SLDIP6R is LLA, SIP6 is set to LLAR If SLDIP6R is GUA, SIP6 is set to GUAR
0x02	LLA	SIP6 is fixed to LLAR.
0x03	GUA	SIP6 is fixed to GUAR.

#### 4.1.17 SLCR (SOCKET-less Command Register)

*[RW, AC] [0x2130] [0x00]*

SLCR performs a command to transmit a specific packet without SOCKET. Command is cleared automatically after completion, and it cannot execute another command before the previous command is cleared. The result of the command execution is confirmed by SLIR (SOCKET-less Interrupt Register).

7	6	5	4	3	2	1	0
-	ARP4	PING4	ARP6	PING6	NS	RS	UNA
	RW	RW	RW	RW	RW	RW	RW

Bit	Symbol	Description
7	-	Reserved
6	ARP4	<b>ARP Request Transmission Command</b> 1 : Transmit ARP Request. 0 : Ready
5	PING4	<b>IPv4 PING Request Transmission Command</b> 1 : Transmit PING Request. 0 : Ready
4	ARP6	<b>NS ARP Transmission Command</b> 1 : Transmit NS ARP. 0 : Ready
3	PING6	<b>IPv6 PING Request Transmission Command</b> 1 : Transmit IPv6 PING Request. 0 : Ready
2	NS	<b>NS Transmission Command for DAD</b> 1 : Transmit NS packet for DAD. 0 : Ready
1	RS	<b>Auto configuration RS Transmission Command</b> 1 : Transmit RS packet. 0 : Ready
0	UNA	<b>Unsolicited NA Transmission Command</b> 1 : Transmit Unsolicited NA packet. 0 : Ready

#### 4.1.18 PHYSR (PHY Status Register)

[RO] [0x3000] [0x00]

PHYSR checks PHY operation mode and LINK status set through PHYCR0(PHY Control Register 0).

7	6	5	4	3	2	1	0
CAB	-	MODE2	MODE1	MODE0	DPX	SPD	LNK
RO		RO	RO	RO	RO	RO	RO

Bit	Symbol	Description																								
7	CAB	<b>Cable OFF bit</b> 1 : Cable Unplugged 0 : Cable Plugged																								
6	-	Reserved																								
[5:3]	MODE [2:0]	<b>PHY OPMODE</b> <table border="1" data-bbox="561 936 1273 1236"> <thead> <tr> <th>MODE2</th> <th>MODE1</th> <th>MODE0</th> <th>Description</th> </tr> </thead> <tbody> <tr> <td>0</td> <td>X</td> <td>X</td> <td>Auto Negotiation</td> </tr> <tr> <td>1</td> <td>0</td> <td>0</td> <td>100BASE-TX FDX</td> </tr> <tr> <td>1</td> <td>0</td> <td>1</td> <td>100BASE-TX HDX</td> </tr> <tr> <td>1</td> <td>1</td> <td>0</td> <td>10BASE-T FDX</td> </tr> <tr> <td>1</td> <td>1</td> <td>1</td> <td>10BASE-T HDX</td> </tr> </tbody> </table>	MODE2	MODE1	MODE0	Description	0	X	X	Auto Negotiation	1	0	0	100BASE-TX FDX	1	0	1	100BASE-TX HDX	1	1	0	10BASE-T FDX	1	1	1	10BASE-T HDX
MODE2	MODE1	MODE0	Description																							
0	X	X	Auto Negotiation																							
1	0	0	100BASE-TX FDX																							
1	0	1	100BASE-TX HDX																							
1	1	0	10BASE-T FDX																							
1	1	1	10BASE-T HDX																							
2	DPX	<b>Flag Duplex bit (When Link Up)</b> 1 : Half Duplex 0 : Full Duplex																								
1	SPD	<b>Flag Speed bit (When Link Up)</b> 1 : 10Mbps 0 : 100Mbps																								
0	LNK	<b>Flag Link bit</b> 1 : Link Up 0 : Link Down																								

#### 4.1.19 PHYRAR (PHY Register Address Register)

[R=W] [0x3008] [0x00]

PHYRAR sets PHY register address in integrated Ethernet PHY.

7	6	5	4	3	2	1	0
-	-	-	A4	A3	A2	A1	A0
			R=W	R=W	R=W	R=W	R=W

Bit	Symbol	Description
[7:5]	-	Reserved
[4:0]	ADDR [4:0]	PHY Register Address Set PHY Register Address

#### 4.1.20 PHYDIR (PHY Data Input Register)

**[R=W] [0x300C-0x300D] [0x0000]**

PHYDIR sets the value to write into the PHY Register specified by PHYRAR.

Ex) PHYDIR = 0x1234

PHYDIR0(0x300C)	PHYDIR1(0x300D)
0x34	0x12

#### 4.1.21 PHYDOR (PHY Data Output Register)

**[RO] [0x3010-0x3011] [0x0000]**

PHYDOR gets the value from the PHY Register specified by PHYRAR.

Ex) PHYDOR = 0x1234

PHYDOR0(0x0042)	PHYDPR1(0x0043)
0x34	0x12

#### 4.1.22 PHYACR (PHY Access Control Register)

**[RW, AC] [0x3014] [0x00]**

PHYACR reads/writes the value in PHYDOR/PHYDIR from/to PHY register specified by PHYRAR. After completion, PHYACR is automatically cleared.

Access Type	Value	related Register
Write	0x01	PHYDIR
Read	0x02	PHYDOR

#### 4.1.23 PHYDIVR (PHY Division Register)

**[R=W] [0x3018] [0x01]**

PHYDIVR is PHY's MDC Clock Division Register (**be careful to not exceed 2.5MHz**).

Value	Divider	SYS_CLK=100MHz	SYS_CLK=25MH
0x00	1/32	3.125MHz (N/A)	781.25KHz
0x01	1/64	1.5625MHz	390.625KHz
Others	1/128	781.25KHz	195.3125KHz

#### 4.1.24 PHYCR0 (PHY Control Register 0)

**[WO] [0x301C] [0x00]**

PHYCR0 sets Ethernet PHY operation mode when SYSR[PHYL] = '0' ((PHYLCKR(PHY Lock Register) is Unlock). Bits set by PHYCR0 can be checked to PHYSR [5:3].

7	6	5	4	3	2	1	0
-	-	-	-	-	MODE2	MODE1	MODE0
					WO	WO	WO

Bit	Symbol	Description																								
[7:3]	-	Reserved																								
[2:0]	MODE	<table border="1"> <thead> <tr> <th>MODE2</th> <th>MODE1</th> <th>MODE0</th> <th>Description</th> </tr> </thead> <tbody> <tr> <td>0</td> <td>x</td> <td>x</td> <td>Auto Negotiation</td> </tr> <tr> <td>1</td> <td>0</td> <td>0</td> <td>100BASE-TX FDX</td> </tr> <tr> <td>1</td> <td>0</td> <td>1</td> <td>100BASE-TX HDX</td> </tr> <tr> <td>1</td> <td>1</td> <td>0</td> <td>10BASE-TX FDX</td> </tr> <tr> <td>1</td> <td>1</td> <td>1</td> <td>10BASE-TX HDX</td> </tr> </tbody> </table>	MODE2	MODE1	MODE0	Description	0	x	x	Auto Negotiation	1	0	0	100BASE-TX FDX	1	0	1	100BASE-TX HDX	1	1	0	10BASE-TX FDX	1	1	1	10BASE-TX HDX
		MODE2	MODE1	MODE0	Description																					
		0	x	x	Auto Negotiation																					
		1	0	0	100BASE-TX FDX																					
		1	0	1	100BASE-TX HDX																					
		1	1	0	10BASE-TX FDX																					
1	1	1	10BASE-TX HDX																							

#### 4.1.25 PHYCR1 (PHY Control Register 1)

**[R=W] [0x301D] [0x40]**

PHYCR1 sets PHY power down Mode and PHY HW Reset when SYSR[PHYL] = '0' ((PHYLCKR(PHY Lock Register) is Unlock).

7	6	5	4	3	2	1	0
-	-	PWDN	-	TE	-	-	RST
-	-	R=W	-	R=W	-	-	AC

Bit	Symbol	Description						
7	-	Reserved						
6	-	Should be always written by '1'						
5	PWDN	<b>PHY Power Down</b> 0 : Disable Power Down Mode SYS_CLK is changed according to SYCR1[CLKSEL].						
		<table border="1"> <thead> <tr> <th>SYCR1[CLKSEL]</th> <th>SYS_CLK</th> </tr> </thead> <tbody> <tr> <td>0</td> <td>100 MHz</td> </tr> <tr> <td>1</td> <td>25 MHz</td> </tr> </tbody> </table>	SYCR1[CLKSEL]	SYS_CLK	0	100 MHz	1	25 MHz
		SYCR1[CLKSEL]	SYS_CLK					
0	100 MHz							
1	25 MHz							

		1 : Enable Power Down Mode SYS_CLK is automatically changed to 25MHz. <i>ref) 8.4.1 Reset Timing</i>
4	-	Reserved
3	TE	10BASE-T <sub>e</sub> MODE It's valid only in case that PHYSR[MODE2:MODE0] = '000'.  0 : Disable 10BASE-T <sub>e</sub> MODE 1 : Enable 10BASE-T <sub>e</sub> MODE
[2:1]	-	Reserved
0	RST	<b>PHY Reset</b> On PHY HW Reset, SYS_CLK is changed to 25MHz. When reset is completed, this bit is cleared automatically and SYS_CLK is restored to the previous setting clock. <i>ref) 8.4.1 Reset Timing</i>  0 : Normal Operation 1 : PHY HW Reset

#### 4.1.26 NET4MR (Network IPv4 Mode Register)

*[R=W] [0x4000] [0x00]*

NET4MR sets special options for IPv4.

7	6	5	4	3	2	1	0
-	-	-	-	UNRB	PARP	RSTB	PB
-	-	-	-	R=W	R=W	R=W	R=W

Bit	Symbol	Description
[7:4]	-	Reserved
3	UNRB	<b>UDP4 Port Unreachable Packet Block</b> When UDP4 packet is transmitted to SOCKET that is not opened, destination port unreachable packet is transmitted. It can be a target of UDP port scan attack. To prevent this, unreachable packet transmission can be blocked.  0 : Unblock 1 : Block
2	PARP	<b>ARIPv4 for PINGv4 Reply</b> Set to issue ARIPv4 before PINGv4 Reply.

		0 : Disable 1 : Enable
1	RSTB	<b>TCP4 RST Packet Block</b> When a SYN Packet is transmitted to the SOCKET which is not listening, the system transmits a RST packet. It can be a target of the TCP Port Scan attack. To prevent this, RST packet transmission can be blocked.  0 : Unblock 1 : Block
0	PB	<b>PINGv4 Reply Block</b> Set to not transmit Reply for PINGv4 Request  0 : Unblock 1 : Block

#### 4.1.27 NET6MR (Network IPv6 Mode Register)

**[R=W] [0x4004] [0x00]**

NET6MR sets special options related to IPv6.

7	6	5	4	3	2	1	0
-	-	-	-	UNRB	PARP	RSTB	PB
-	-	-	-	R=W	R=W	R=W	R=W

Bit	Symbol	Description
[7:4]	-	Reserved
3	UNRB	<b>UDP6 Port Unreachable Packet Block</b> When UDP6 packet is transmitted to the SOCKET that is not opened, destination port unreachable packet is transmitted. It can be a target of UDP port scan attack. To prevent this, unreachable packet transmission can be blocked.  0 : Unblock 1 : Block
2	PARP	<b>ARPV6 for PINGv6 Reply</b> It sets to run ARP6(ND - Neighbor Discovery) process before PINGv6 Reply.  0 : Disable 1 : Enable

1	RSTB	<b>TCP6 RST Packet Block</b> When a SYN Packet is transmitted to the SOCKET that is not listening, the system transmits a RST packet. It can be a target of the TCP Port Scan attack. To prevent this, RST packet transmission can be blocked.  0 : Unblock 1 : Block
0	PB	<b>PINGv6 Reply Block</b> Set to not transmit Reply for PINGv6 Request  0 : Unblock 1 : Block

#### 4.1.28 NETMR (Network Mode Register)

*[R=W] [0x4008] [0x00]*

NETMR sets Block mode and WOL.

7	6	5	4	3	2	1	0
-	-	ANB	M6B	-	WOL	IP6B	IP4B
-	-	R=W	R=W	-	R=W	R=W	R=W

Bit	Symbol	Description
[7:6]	-	Reserved Should be always '0'.
5	ANB	<b>IPv6 ALLNODE Block</b> Block PING6-Request with All-Node Multicasting address.  0 : Disable 1 : Enable
4	M6B	<b>IPv6 Multicast Block</b> Block the PING6-Request with Multicasting group address.  0 : Disable 1 : Enable
3	-	Reserved Should be always '0'
2	WOL	<b>WOL(Wake On LAN)</b> 0 : Disable 1 : Enable

1	IP6B	<b>IPv6 Packet Block</b> 0 : Unblock 1 : Block - ANB & M6B bit is ignored.
0	IP4B	<b>IPv4 Packet Block</b> 0 : Unblock 1 : Block

#### 4.1.29 NETMR2 (Network Mode Register 2)

**[R=W] [0x4009] [0x00]**

NETMR2 sets PPPoE mode.

7	6	5	4	3	2	1	0
DHAS	-	-	-	-	-	-	PPPoE
R=W	-	-	-	-	-	-	R=W

Bit	Symbol	Description
7	DHAS	<b>Destination Hardware Address Selection in ARP/ND-process</b> 0 : Select the Ethernet Frame MAC 1 : Select the ARP Target MAC
[6:1]	-	Reserved
0	PPPoE	<b>PPPoE Mode</b> 0 : PPP Mode disable 1 : PPP Mode enable

#### 4.1.30 PTMR (PPP Link Control Protocol Request Timer Register)

**[R=W] [0x4100] [0x28]**

PTMR sets the time for sending the LCP echo request.

The unit is 25ms. PTMR is valid only in PPPoE mode.

Ex) PTMR = 200 (0xC8),

200 \* 25ms = 5s

#### 4.1.31 PMNR (PPP Link Control Protocol Magic number Register)

**[R=W] [0x4104] [0x00]**

PMNR sets 4 Bytes magic number to be used in LCP negotiation.

PMNR is valid only in PPPoE mode.

Ex) PMNR = 0x01

PMNR(0x4104)

0x01

LCP Magic number = 0x01010101

#### 4.1.32 PHAR (PPPoE Server Hardware Address Register on PPPoE)

**[R=W] [0x4108-0x410D] [0x0000]**

PHAR sets PPPoE destination hardware address.

PHAR is valid only in PPPoE mode.

Ex) PHAR = "11:22:33:AA:BB:CC"

PHAR0(0x4108)	PHAR1(0x4109)	PHAR2(0x410A)
0x11	0x22	0x33
PHAR3(0x410B)	PHAR4(0x410C)	PHAR5(0x410D)
0xAA	0xBB	0xCC

#### 4.1.33 PSIDR (PPPoE Session ID Register on PPPoE)

**[R=W] [0x4110-0x4111] [0x0000]**

PSIDR sets PPPoE session ID.

PSIDR is valid only in PPPoE mode.

Ex) PSIDR = 0x1234

PSIDR0(0x4110)	PSIDR1(0x4111)
0x12	0x34

#### 4.1.34 PMRUR (PPPoE Maximum Receive Unit Register)

**[R=W] [0x4114-0x4115] [0xFFFF]**

PMRUR sets the MRU (Maximum Receive Unit) in PPPoE mode. If PMRUR is set to a value larger than 1472, it is automatically set to 1472. PMRUR must be set before SOCKET creation (Sn\_CR [OPEN] = '1').

PMRUR is valid only in PPPoE mode.

Ex) PMUR = 1000 (0x03E8)

PMUR0(0x4114)	PMUR1(0x4115)
0x03	0xE8

#### 4.1.35 SHAR (Source Hardware Address Register)

**[R=W] [0x4120-0x4125] [0x0000\_0000\_0000]**

SHAR sets the source hardware address when SYSR [NETL] = '0' (NETLCKR (Network Lock Register) is Unlocked).

Ex) SHAR = "11:22:33:AA:BB:CC"

SHAR0(0x4120)	SHAR1(0x4121)	SHAR2(0x4122)
0x11	0x22	0x33
SHAR3(0x4123)	SHAR4(0x4124)	SHAR5(0x4125)
0xAA	0xBB	0xCC

#### 4.1.36 GAR (Gateway IP Address Register)

**[R=W] [0x4130-0x4133] [0x0000\_0000]**

The GAR sets the source gateway address when SYSR [NETL] = '0' (NETLCKR (Network Lock Register) is Unlocked).

Ex) GAR = "192.168.0.1"

GAR0(0x4130)	GAR1(0x4131)	GAR2(0x4132)	GAR3(0x4133)
192 (0xC0)	168 (0xA8)	0 (0x00)	1 (0x01)

#### 4.1.37 SUBR (Subnet Mask Register)

**[R=W] [0x4134-0x4137] [0x0000\_0000]**

SUBR sets the subnet mask when SYSR [NETL] = '0' (NETLCKR (Network Lock Register) is Unlocked).

Ex) SUBR = "255.255.255.255"

SUBR0(0x4134)	SUBR0(0x4135)	SUBR0(0x4136)	SUBR0(0x4137)
255 (0xFF)	255 (0xFF)	255 (0xFF)	255 (0xFF)

#### 4.1.38 SIPR (IPv4 Source Address Register)

**[R=W] [0x4138-0x413B] [0x0000\_0000]**

SIPR sets the source IP address when SYSR [NETL] = '0' (NETLCKR (Network Lock Register) is Unlocked).

Ex) SIPR = "192.168.0.100"

SIPR0(x4138)	SIPR1(0x4139)	SIPR2(0x413A)	SIPR3(0x413B)
192 (0xC0)	168 (0xA8)	0 (0x00)	100(0x64)

### 4.1.39 LLAR (Link Local Address Register)

*[R=W] [0x4140-0x414F] [0x0000\_0000\_0000\_0000\_0000\_0000\_0000\_0000]*

LLAR sets the link local address when SYSR [NETL] = '0' (NETLCKR (Network Lock Register) is Unlocked).

Ex) LLAR = "FE80::AB:CDEF"

LLAR0(0x4140)	LLAR1(0x4141)	LLAR2(0x4142)	LLAR3(0x4143)
0xFE	0x80	0x00	0x00
LLAR4(0x4144)	LLAR5(0x4145)	LLAR6(0x4146)	LLAR7(0x4147)
0x00	0x00	0x00	0x00
LLAR8(0x4148)	LLAR9(0x4149)	LLAR10(0x414A)	LLAR11(0x414B)
0x00	0x00	0x00	0x00
LLAR12(0x414C)	LLAR13(0x414D)	LLAR14(0x414E)	LLAR15(0x414F)
0x00	0xAB	0xCD	0xEF

### 4.1.40 GUAR (Global Unicast Address Register)

*[R=W] [0x4150-0x415F] [0x0000\_0000\_0000\_0000\_0000\_0000\_0000\_0000]*

GUAR sets global unicast address when SYSR [NETL] = '0' (NETLCKR (Network Lock Register) is Unlocked).

Ex) GUAR = "2001::AB:CDEF"

GUAR0(0x4150)	GUAR1(0x4151)	GUAR2(0x4152)	GUAR3(0x4153)
0x20	0x01	0x00	0x00
GUAR4(0x4154)	GUAR5(0x4155)	GUAR6(0x4156)	GUAR7(0x4157)
0x00	0x00	0x00	0x00
GUAR8(0x4158)	GUAR9(0x4159)	GUAR10(0x415A)	GUAR11(0x415B)
0x00	0x00	0x00	0x00
GUAR12(0x415C)	GUAR13(0x415D)	GUAR14(0x415E)	GUAR15(0x415F)
0x00	0xAB	0xCD	0xEF

### 4.1.41 SUB6R (IPv6 Subnet Prefix Register)

*[R=W] [0x4160-0x416F] [0x0000\_0000\_0000\_0000\_0000\_0000\_0000\_0000]*

SUB6R sets a prefix mask when SYSR [NETL] = '0' (NETLCKR (Network Lock Register) is Unlocked).

Ex) SUB6R = "FFFF:FFFF:FFFF:FFFF::"

PRFXR0(0x4160)	PRFXR1(0x4161)	PRFXR2(0x4162)	PRFXR3(0x4163)
0xFF	0xFF	0xFF	0xFF

PRFXR4(0x4164)	PRFXR5(0x4165)	PRFXR6(0x4166)	PRFXR7(0x4167)
0xFF	0xFF	0xFF	0xFF
PRFXR8(0x4168)	PRFXR9(0x4169)	PRFXR10(0x416A)	PRFXR11(0x416B)
0x00	0x00	0x00	0x00
PRFXR12(0x416C)	PRFXR13(0x416D)	PRFXR14(0x416E)	PRFXR15(0x416F)
0x00	0x00	0x00	0x00

#### 4.1.42 GA6R (IPv6 Gateway Address Register)

**[R=W] [0x4170-0x417F] [0x0000\_0000\_0000\_0000\_0000\_0000\_0000\_0000]**

GA6R sets gateway IPv6 address.

Ex) GA6R = "FE80::FE:DCBA"

GA6R0(0x4170)	GA6R1(0x4171)	GA6R2(0x4172)	GA6R3(0x4173)
0xFE	0x80	0x00	0x00
GA6R4(0x4174)	GA6R5(0x4175)	GA6R6(0x4176)	GA6R7(0x4177)
0x00	0x00	0x00	0x00
GA6R8(0x4178)	GA6R9(0x4179)	GA6R10(0x417A)	GA6R11(0x417B)
0x00	0x00	0x00	0x00
GA6R12(0x417C)	GA6R13(0x417D)	GA6R14(0x417E)	GA6R15(0x417F)
0x00	0xFE	0xDC	0xBA

#### 4.1.43 SLDIP6R (SOCKET-less Destination IPv6 Address Register)

**[R=W] [0x4180-0x418F] [0x0000\_0000\_0000\_0000\_0000\_0000\_0000\_0000]**

SLDIPR sets destination IPv6 address for packet transmission by SLCR.

Ex) SLDIPR = "FE80::AB:CDEF"

SLDIP6R0(0x4180)	SLDIP6R1(0x4181)	SLDIP6R2(0x4182)	SLDIP6R3(0x4183)
0xFE	0x80	0x00	0x00
SLDIP6R4(0x4184)	SLDIP6R5(0x4185)	SLDIP6R6(0x4186)	SLDIP6R7(0x4187)
0x00	0x00	0x00	0x00
SLDIP6R8(0x4188)	SLDIP6R9(0x4189)	SLDIP6R10(0x418A)	SLDIP6R11(0x418B)
0x00	0x00	0x00	0x00
SLDIP6R12(0x418C)	SLDIP6R13(0x418D)	SLDIP6R14(0x418E)	SLDIP6R15(0x418F)
0x00	0xAB	0xCD	0xEF

#### 4.1.44 SLDIPR (SOCKET-less Destination IPv4 Address Register)

**[R=W] [0x418C-0x418F] 0x00000000]**

SLDIPR sets destination IPv4 address for packet transmission by SLCR.

SLDIPR address is shared from SLDIPR12 (0x418C) to SLDIPR15 (0x418F).

Ex) SLDIPR = “192.169.0.21”

SLDIPR0 / SLDIP6R12(0x418C)	SLDIPR1 / SLDIP6R13(0x418D)	SLDIPR2 / SLDIP6R14(0x418E)	SLDIPR3 / SLDIP6R15(0x418F)
192(0xC0)	168(0xA8)	0(0x00)	21(0x15)

#### 4.1.45 SLDHAR (SOCKET-less Destination Hardware Address Register)

**[RO] [0x4190-0x4195] [0x0000\_0000\_0000]**

SLDHAR sets destination hardware address when reply packet of SLCR[ARP4] or SLCR[ARP6] is received.

Ex) SLDHAR = “11:22:33:AA:BB:CC”

SLDHAR0(0x4190)	SLDHAR1(0x4191)	SLDHAR2(0x4192)
0x11	0x22	0x33
SLDHAR3(0x4193)	SLDHAR4(0x4194)	SLDHAR5(0x4195)
0xAA	0xBB	0xCC

#### 4.1.46 PINGIDR (PING ID Register)

**[R=W] [0x4198-0x4199] [0x0000]**

PINGIDR sets the ID of the ping request packet to be transmitted by SLCR [PING4] or SLCR [PING6].

Ex) PINGIDR = 256 (0x0100)

PINGIDR0(0x4198)	PINGIDR1(0x4199)
0x61	0x00

#### 4.1.47 PINGSEQR (PING Sequence-number Register)

**[R=W] [0x419C-0x419D] [0x0000]**

PINGSEQR sets the sequence number of the PING request packet to be transmitted by SLCR [PING4] or SLCR [PING6], and does not increase automatically.

Ex) PINGSEQR = 1000 (0x03E8)

PINGSEQR0(0x419C)	PINGSEQR1(0x419D)
0x03	0xE8

#### 4.1.48 UIPR (Unreachable IP Address Register)

**[RO] [0x41A0-0x41A3] [0x0000\_0000]**

UIPR is set to the destination IPv4 address of the received packet when receiving ICMPv4 Unreachable Packet (IR[UNR4] = '1').

Ex) Unreachable IP Address = "192.169.10.10"

UIPR0(0x41A0)	UIPR1(0x41A1)	UIPR2(0x41A2)	UIPR3(0x41A3)
192(0xC0)	168(0xA8)	10(0x0A)	10(0x0A)

#### 4.1.49 UPORTR (Unreachable Port Register)

**[RO] [0x41A4-0x41A5] [0x0000]**

UPORTR is set to the destination port of the received packet when receiving ICMPv4 unreachable packet (IR[UNR4] = '1').

Ex) Unreachable PORT = "3000" (0x0BB8)

UPORTR0(0x41A4)	UPORTR1(0x41A5)
0x0B	0xB8

#### 4.1.50 UIP6R (Unreachable IPv6 Address Register)

**[RO] [0x41B0-0x41BF] [0x0000\_0000\_0000\_0000\_0000\_0000\_0000\_0000]**

UIP6R is set to the destination IPv6 address of the received packet when receiving ICMPv6 unreachable packet (IR[UNR6] = '1').

Ex) Unreachable IP is "FE80::AB:CDEF"

UIP6R0(0x41B0)	UIP6R1(0x41B1)	UIP6R2(0x41B2)	UIP6R3(0x41B3)
0xFE	0x80	0x00	0x00
UIP6R4(0x41B4)	UIP6R5(0x41B5)	UIP6R6(0x41B6)	UIP6R7(0x41B7)
0x00	0x00	0x00	0x00
UIP6R8(0x41B8)	UIP6R9(0x41B9)	UIP6R10(0x41BA)	UIP6R11(0x41BB)
0x00	0x00	0x00	0x00
UIP6R12(0x41BC)	UIP6R13(0x41BD)	UIP6R14(0x41BE)	UIP6R15(0x41BF)
0x00	0xAB	0xCD	0xEF

#### 4.1.51 UPORT6R (Unreachable IPv6 Port Register)

**[RO] [0x41C0-0x41C1] [0x0000]**

UPOINT6R is set to the Destination Port of the received packet when receiving ICMPv6 Unreachable Packet (IR[UNR6] = '1').

Ex) Unreachable PORT is "3000" (0x0BB8)

UPOINT6R0(0x41C0)	UPOINT6R1(0x41C1)
0x0B	0xB8

#### 4.1.52 INTPTMR (Interrupt Pending Time Register)

**[RW][0x41C5-0x41C6][0x0000]**

INTPTMR sets the internal interrupt pending timer count. The timer count is initialized by the value in INTPTMR when INTn is de-asserted to HIGH, and is decremented by 1 in 4 clocks of SYS\_CLK from at the time when the interrupt occurred until it becomes 0.

INTn is asserted to LOW when an interrupt occurs and the corresponding interrupt mask is enabled and INTPTMR = 0.

Ex) INTPTMR = 1000(0x03EB)

INTPTMR0(0x41C5)	INTPTMR1(0x41C6)
0x03	0xEB

#### 4.1.53 PLR (Prefix Length Register)

**[RO][0x41D0][0x00]**

PLR is set to prefix length field in prefix information option of RA (Router Advertisement) message received from a router (SLIR[RS] = 1 or SLIR[RA] = '1').

Ex) RA Prefix Length = 0x10

PLR(0x41D0)
0x10

#### 4.1.54 PFR (Prefix Flag Register)

**[RO][0x41D4][0x00]**

PFR is set to prefix flag field in prefix information option of RA (Router Advertisement) message received from a router (SLIR[RS] = 1 or SLIR[RA] = '1').

Ex) Flag = 0xC0

PFR(0x41D4)
0xC0

#### 4.1.55 VLTR (Valid Life Time Register)

**[RO][0x41D8-0x41DB][0x0000\_0000]**

VLTR is set to valid life time field in prefix information option of RA (Router Advertisement) message received from a router (SLIR[RS] = 1 or SLIR[RA] = '1').

Ex) Valid Life Time = 2592000

VLTR0(0x41D8)	VLTR1(0x41D9)	VLTR2(0x41DA)	VLTR3(0x41DB)
0x00	0x27	0x8D	0x00

#### 4.1.56 PLTR (Preferred Life Time Register)

**[RO] [0x41DC-0x41DF] [0x0000\_0000]**

PLTR is set to preferred life time field in prefix information option of RA (Router Advertisement) message received from a router (SLIR[RS] = 1 or SLIR[RA] = '1').

Ex) Preferred Life Time = 604800

PLTR0(0x41DC)	PLTR1(0x41DD)	PLTR2(0x41DE)	PLTR3(0x41DF)
0x00	0x09	0x3A	0x80

#### 4.1.57 PAR (Prefix Address Register)

**[RO] [0x41E0-0x41EF] [0x0000\_0000\_0000\_0000\_0000\_0000\_0000\_0000]**

PAR is set to prefix address field in prefix information option of RA (Router Advertisement) message received from a router (SLIR[RS] = 1 or SLIR[RA] = '1').

Ex) Prefix is "2001:2b8:10:1::"

PAR0(0x41E0)	PAR1(0x41E1)	PAR2(0x41E2)	PAR3(0x41E3)
0x20	0x01	0x02	0xb8
PAR4(0x41E4)	PAR5(0x41E5)	PAR6(0x41E6)	PAR7(0x41E7)
0x00	0x10	0x00	0x01
PAR8(0x41E8)	PAR9(0x41E9)	PAR10(0x41EA)	PAR11(0x41EB)
0x00	0x00	0x00	0x00
PAR12(0x41EC)	PAR13(0x41ED)	PAR14(0x41EE)	PAR15(0x41EF)
0x00	0x00	0x00	0x00

#### 4.1.58 ICMP6BLKR (ICMPv6 Block Register)

**[R=W] [0x41F0] [0x00]**

ICMP6BLKR can selectively set blocking ICMPv6 packets such as PING6, Multicast Listener Discovery (MLD) Query, Router Advertisement (RA), Neighbor Advertisement (NA), and Neighbor Solicitation (NS). Block Packets can be received via IPRAW6 SOCKET.

7	6	5	4	3	2	1	0
			PING6	MLD	RA	NA	NS
			R=W	R=W	R=W	R=W	R=W

Bit	Symbol	Description
[7:5]	-	Reserved
4	PING6	<b>ICMPv6 Echo Request Block</b> 1 : Block Echo Request Packet 0 : Normal Operation
3	MLD	<b>ICMPv6 Multicast Listener Discovery(MLD) Query Block</b> 1 : Block Multicast Listener Discovery Query Packet 0 : Normal Operation
2	RA	<b>ICMPv6 Router Advertisement Block</b> 1 : Block Router Advertisement Packet 0 : Normal Operation
1	NA	<b>ICMPv6 Neighbor Advertisement Block</b> 1 : Block Neighbor Advertisement Packet 0 : Normal Operation
0	NS	<b>ICMPv6 Neighbor Solicitation Block</b> 1 : Block Neighbor Solicitation Packet 0 : Normal Operation

#### 4.1.59 CHPLCKR (Chip Lock Register)

**[WO] [0x41F4] [0x00]**

CHPLCKR sets SYSR[CHPL].

If SYSR [CHPL] is 'Unlock', SYCR0 and SYCR1 can be set.

Unlock	Lock
0xCE	Others

#### 4.1.60 NETLCKR (Network Lock Register)

**[WO] [0x41F5] [0x00]**

NETLCKR sets SYSR[NETL].

If SYSR [NETL] is 'Unlock', Network Configuration Registers (SHAR, GAR, SUBR, SIPR, LLAR, GUAR, SUB6R) can be set.

Unlock	Lock
0x3A	0xC5

#### 4.1.61 PHYLCKR (PHY Lock Register)

**[WO] [0x41F6] [0x00]**

PHYLCKR sets SYSR[PHYL].

If SYSR[PHYL] is 'Unlock', PHYCR0 and PHYCR1 can be set.

Unlock	Lock
0x53	Others

#### 4.1.62 RTR (Retransmission Time Register)

**[R=W] [0x4200-0x4201] [0x07D0]**

RTR sets the initial value of Sn\_RTR (SOCKET n Retransmission Time Register).

The unit is 100us.

It is involved in retransmission of packet (ARP/ND, TCP) with an RCR (Retransmission Counter Register). Refer to [6.7 Retransmission](#).

Ex) RTR = 5000 (0x1388)

$$5000 * 100\mu s = 0.5s$$

RTR0(0x4200)	RTR1(0x4201)
0x13	0x88

#### 4.1.63 RCR (Retransmission Count Register)

**[R=W] [0x4204] [0x07]**

RCR sets the initial value of Sn\_RCR (SOCKET n Retransmission Count Register).

It is involved in retransmission of packet (ARP/ND, TCP) with an RTR (Retransmission Time Register). Refer to [6.7 Retransmission](#).

#### 4.1.64 SLRTR (SOCKET-less Retransmission Time Register)

**[R=W] [0x4208-0x4209] [0x07D0]**

SLRTR sets the Retransmission Time of SLCR.

The unit is 100us.

If there is no response to the request packet transmitted by the SLCR, retransmission occurs. If the number of retransmissions exceeds the value specified in the SLRCR (SOCKET-less Retransmission Count Register), Timeout occurs (SLIR [TOUT] = '1').

Refer to [6.7 Retransmission](#).

Ex) SLRTR = 5000 (0x1388),

$$5000 * 100\mu s = 0.5s$$

SLRTR0(0x4208)	SLRTR1(0x4209)
0x013	0x88

---

#### 4.1.65 SLRCR (SOCKET-less Retransmission Count Register)

**[R=W] [0x420C] [0x00]**

The SLRCR sets the Retransmission Counter of the SLCR.

If the retransmission counter exceeds SLRCR, SLIR [TOUT] becomes '1'.

Refer to [6.7 Retransmission](#).

#### 4.1.66 SLHOPR (Hop limit Register)

**[RW] [0x420F] [0x80]**

Sets the HOP of ND Messages (NS, NA) transmitted by SLCR.

Ex) SLHOPR = 128

SLHOPR(0x420F)
----------------

0x80 (128)
------------

## 4.2 SOCKET Register

### 4.2.1 Sn\_MR (SOCKET n Mode Register)

**[R=W] [0x0000] [0x00]**

Sn\_MR sets SOCKET mode and options. It must be set before SOCKET OPEN (Sn\_CR[OPEN] = '1').

7	6	5	4	3	2	1	0
MULTI/ MF	BRDB/ FPSH	ND/ MC/ SMB/ MMB	UNIB/ MMB6	P3	P2	P1	P0
R=W	R=W	R=W	R=W	R=W	R=W	R=W	R=W

Bit	Symbol	Description
7	MULTI/ MF	<p><b>MULTI : Multicast Mode</b> It is valid when Sn_MR[3:0] is UDP4, UDP6 or UDPD. <i>ref) 6.3.3 UDP Multicast</i> 0 : Disable UDP Multicast 1 : Enable UDP Multicast</p> <p><b>MF : MAC Filter Enable</b> It is valid when Sn_MR[3:0] is MACRAW mode. 0 : Disable MAC Filter (Receive All Packets) 1 : Enable MAC Filter (Receive only Multicast, Broadcast and Source MAC(SHAR) Address Packets)</p>
6	BRDB/ FPSH	<p><b>BRDB : Broadcast Block</b> It is valid when Sn_MR[3:0] is UDP4, UDP6, UDPD or MACRAW mode. <i>ref) 6.3.2 UDP Broadcast</i> 0 : Disable UDP Broadcast Block 1 : Enable UDP Broadcast Block</p> <p><b>FPSH : Force Push flag</b> It sets PSH flag in DATA packet forcedly when Sn_MR[3:0] is TCP4, TCP6 or TCPD. 0 : Disable Force PSH flag (Set PSH flag only in the last DATA Packet sent by SEND Command) 1 : Enable Force PSH flag</p>
5	ND/ MC/	<p><b>ND : No Delayed ACK</b> It is valid when Sn_MR[3:0] is TCP4, TCP6 or TCPD. 0 : Disable No Delayed ACK (Send ACK Packet after Sn_RTR)</p>

	SMB/ MMB	<p>1 : Enable No Delayed ACK (Send ACK Packet after receiving DATA Packet)</p> <p><i>ref) After Sn_CR[RECV], if SOCKET Window Size is smaller than MSS, ACK Packet sent immediately. And it is unrelated with ND.</i></p> <p><b>MC : Multicast IGMP Version</b> MC bit is used when Sn_MR[3:0] is UDP4 and Sn_MR[MULTI] is '1'. 0 : Using IGMP version 2 1 : Using IGMP version 1</p> <p><b>SMB : UDP6 Solicited Multicast Block</b> SMB bit is used when Sn_MR[3:0] is UDP6 or UDPD. It blocks receiving Packet sent to Solicited Multicast Address in W6100. 0 : Disable Solicited Multicast Block 1 : Enable Solicited Multicast Block</p> <p><b>MMB : UDP4 Multicast Block in MACRAW Mode</b> It is valid when Sn_MR [3:0] is MACRAW and Sn_MR [MF] is '1'. 0 : Normal Mode 1 : Block IPv4 Multicast</p>								
4	UNIB/ MMB6	<p><b>UNIB : Unicast Block</b> It is valid when Sn_MR[3:0] is UDP4, UDP6 or UDPD. <i>ref) <a href="#">6.3.5.2 UDP Block</a></i> 0 : Disable UDP Unicast Block 1 : Enable UDP Unicast Block</p> <p><b>MMB6 : UDP6 Multicast Block in MACRAW Mode</b> It is valid when Sn_MR [3:0] is MACRAW and Sn_MR [MF] is '1'. 0 : Normal Mode 1 : Block IPv6 Multicast</p>								
[3:0]	P[3:0]	<p><b>P[3:0] : Protocol Mode</b> It sets SOCKET Protocol Mode. MACRAW mode is only available on SOCKET 0.</p> <table border="1" data-bbox="699 1865 1150 2063"> <thead> <tr> <th>P[3:0]</th> <th>Protocol Mode</th> </tr> </thead> <tbody> <tr> <td>0000</td> <td>SOCKET Closed</td> </tr> <tr> <td>0001</td> <td>TCP4</td> </tr> <tr> <td>0010</td> <td>UDP4</td> </tr> </tbody> </table>	P[3:0]	Protocol Mode	0000	SOCKET Closed	0001	TCP4	0010	UDP4
P[3:0]	Protocol Mode									
0000	SOCKET Closed									
0001	TCP4									
0010	UDP4									

		0011	IPRAW4
		0111	MACRAW
		1001	TCP6
		1010	UDP6
		1011	IPRAW6
		1101	TCP Dual (TCPD)
		1110	UDP Dual (UDPD)

#### 4.2.2 Sn\_PSR (SOCKET n Prefer Source IPv6 Address Register)

**[RW] [0x0004] [0x00]**

Sn\_PSR sets source IPv6 Address (SIP6) of SOCKET n.

Vaule	Symbol	Description
-0x00	AUTO	Depending on destination IPv6 Address (DIP6), source IPv6 Address (SIP6) is automatically set. If DIP6 is LLA, SIP6 is set LLA. If DIP6 is GUA, SIP6 is set GUA.
0x02	LLA	SIP6 is set as LLA.
0x03	GUA	SIP6 is set as GUA.

#### 4.2.3 Sn\_CR (SOCKET n Command Register)

**[RW,AC] [0x0010] [0x00]**

Sn\_CR sets SOCKET command bits. After a command operation, the command bit is automatically cleared. The next command bit cannot be operated before the previous command bit is cleared.

Value	Symbol	Description																						
0x01	OPEN	<p><b>OPEN Command</b></p> <p>Before SOCKET OPEN Command, SOCKET mode must be set by Sn_MR. After OPEN Command, Sn_SR describes SOCKET status as below.</p> <table border="1" data-bbox="588 472 1287 1016"> <thead> <tr> <th>Sn_MR (P[3:0])</th> <th>Sn_SR</th> </tr> </thead> <tbody> <tr> <td>Sn_MR_CLOSE('0000')</td> <td>SOCK_CLOSED(0x00)</td> </tr> <tr> <td>Sn_MR_TCP('0001')</td> <td>SOCK_INIT(0x13)</td> </tr> <tr> <td>Sn_MR_UDP('0010')</td> <td>SOCK_UDP(0x22)</td> </tr> <tr> <td>Sn_MR_IPRAW('0011')</td> <td>SOCK_IPRAW(0x32)</td> </tr> <tr> <td>SO_MR_MACRAW('0111')</td> <td>SOCK_MACRAW(0x42)</td> </tr> <tr> <td>Sn_MR_TCP6('1001')</td> <td>SOCK_INIT(0x13)</td> </tr> <tr> <td>Sn_MR_UDP6('1010')</td> <td>SOCK_UDP(0x22)</td> </tr> <tr> <td>Sn_MR_IPRAW6('1011')</td> <td>SOCK_IPRAW6(0x33)</td> </tr> <tr> <td>Sn_MR_TCPD('1101')</td> <td>SOCK_INIT(0x13)</td> </tr> <tr> <td>Sn_MR_UDPD('1110')</td> <td>SOCK_UDP(0x22)</td> </tr> </tbody> </table>	Sn_MR (P[3:0])	Sn_SR	Sn_MR_CLOSE('0000')	SOCK_CLOSED(0x00)	Sn_MR_TCP('0001')	SOCK_INIT(0x13)	Sn_MR_UDP('0010')	SOCK_UDP(0x22)	Sn_MR_IPRAW('0011')	SOCK_IPRAW(0x32)	SO_MR_MACRAW('0111')	SOCK_MACRAW(0x42)	Sn_MR_TCP6('1001')	SOCK_INIT(0x13)	Sn_MR_UDP6('1010')	SOCK_UDP(0x22)	Sn_MR_IPRAW6('1011')	SOCK_IPRAW6(0x33)	Sn_MR_TCPD('1101')	SOCK_INIT(0x13)	Sn_MR_UDPD('1110')	SOCK_UDP(0x22)
Sn_MR (P[3:0])	Sn_SR																							
Sn_MR_CLOSE('0000')	SOCK_CLOSED(0x00)																							
Sn_MR_TCP('0001')	SOCK_INIT(0x13)																							
Sn_MR_UDP('0010')	SOCK_UDP(0x22)																							
Sn_MR_IPRAW('0011')	SOCK_IPRAW(0x32)																							
SO_MR_MACRAW('0111')	SOCK_MACRAW(0x42)																							
Sn_MR_TCP6('1001')	SOCK_INIT(0x13)																							
Sn_MR_UDP6('1010')	SOCK_UDP(0x22)																							
Sn_MR_IPRAW6('1011')	SOCK_IPRAW6(0x33)																							
Sn_MR_TCPD('1101')	SOCK_INIT(0x13)																							
Sn_MR_UDPD('1110')	SOCK_UDP(0x22)																							
0x02	LISTEN	<p><b>LISTEN Command</b></p> <p>If SOCKET mode is TCP4, TCP6 or TCPD and Sn_SR is SOCK_INIT, SOCKET waits for 'TCP CLIENT' connection after LISTEN command.  <i>ref) 6.2.1 TCP SERVER : LISTEN</i></p>																						
0x04	CONNECT	<p><b>TCP CONNECT Command</b></p> <p>If SOCKET mode is TCP4 or TCPD, and Sn_SR is SOCK_INIT, SOCKET requests the connection to 'TCP SERVER' after CONNECT command.  <i>ref) 0</i>            TCP C <i>CLIENT : CONNECT</i></p>																						
0x84	CONNECT6	<p><b>TCP6 CONNECT Command</b></p> <p>If SOCKET mode is TCP6 or TCPD, and Sn_SR is SOCK_INIT, SOCKET requests the connection to 'TCP SERVER' after CONNECT command.  <i>ref) 0</i>            TCP C <i>CLIENT : CONNECT</i></p>																						
0x08	DISCON	<p><b>TCP DISCON Command</b></p> <p>If SOCKET mode is TCP4, TCP6 or TCPD and Sn_SR is SOCK_ESTABLISHED or SOCK_CLOSE_WAIT, SOCKET requests the disconnection (FIN Packet) to the connected destination.  <i>ref) 6.2.1 TCP S SERVER : Disconnected (Active Close)</i></p>																						
0x10	CLOSE	<p><b>CLOSE Command</b></p>																						

		<p>By CLOSE command, SOCKET is closed immediately and Sn_SR changes to SOCK_CLOSED regardless of the previous status.</p> <p><b>* CAUTION :</b> In TCP4, TCP6 and TCPD Mode, SOCKET is closed without sending FIN Packet</p>
0x20	SEND *	<p><b>SEND Command</b></p> <p>SOCKET sends DATA packet in TCP4, TCP6, TCPD, UDP4, UDPD, IPRAW4 and MACRAW mode.</p>
0xA0	SEND6 *	<p><b>IPv6 SOCKET SEND Command</b></p> <p>SOCKET sends DATA packet in UDP6, UDPD and IPRAW6 mode.</p>
0x22	SEND_KEEP	<p><b>TCP SEND_KEEP Command</b></p> <p>SEND_KEEP command is used only in TCP4, TCP6 and TCPD mode and It is valid only in case that HOST sent at least 1 Byte DATA before SEND_KEEP command.</p> <p>SEND_KEEP command sends Keep Alive (KA) packet to peer for checking if TCP connection is still valid. If ACK packet for KA packet is not received, Sn_IR[TIMEOUT] occurs and Sn_SR is set SOCK_CLOSED after the configured retransmission time.</p> <p><i>ref) 6.2.4.2 Keep Alive</i></p>
0x40	RECV	<p><b>SOCKET RECV Command</b></p> <p>By RECV command, HOST can read data received in SOCKET n RX Buffer block. Sn_RX_RD(SOCKET n Read Pointer Register) must be increased by the size of the read data.</p> <p><i>ref) 4.2.28 Sn_RX_RSR (SOCKET n RX Received Size Register), 4.2.30 Sn_RX_WR (SOCKET n RX Write Pointer Register), 4.2.29 Sn_RX_RD (SOCKET n RX Read Pointer Register)</i></p>

\* By SEND or SEND6 Commands, SOCKET sends DATA and the DATA size is calculated by Sn\_TX\_WR(SOCKET n TX Write Pointer Register) and Sn\_TX\_RD(SOCKET n TX Read Pointer Register). Sending DATA must not exceed Sn\_TX\_FSR(SOCKET n TX Free Buffer Size Register) and HOST sets next SEND Command after Sn\_IR[SENDOK] = '1'.

\* In TCP4, TCP6, TCPD, UDP4, UDP6 and UDPD Mode, if the sending DATA exceeds MSS(Maximum Segment Size), the sending DATA is automatically divided by MSS and transmitted.

\* In IPRAW4, IPRAW6 and MACRAW Mode, HOST must divide DATA by MSS.

\* In TCP4, TCP6 and TCPD Mode, if SOCKET could not successfully send DATA (no receives ACK Packet) to Destination, SOCKET will be closed and Sn\_IR[TIMEOUT] & Sn\_SR[SOCK\_CLOSED] occurs.

\* In TCP4, TCP6, TCPD, UDP4, UDP6, UDPD, IPRAW4, IPRAW6 and MACRAW Mode, Sn\_TX\_FSR is increased by sent DATA Size after Sn\_IR[SENDOK] = '1'.

## 4.2.4 Sn\_IR (SOCKET n Interrupt Register)

**[RO] [0x0020] [0x00]**

Sn\_IR describes the status of SOCKET n or the results of Sn\_CR.

If an event registered in Sn\_IR occurs and the corresponding masking bit in Sn\_IMR is set, SIR[Sn\_INT] is set by '1'.

7	6	5	4	3	2	1	0
-	-	-	SENDOK	TIMEOUT	RECV	DISCON	CON
			RO	RO	RO	RO	RO

Bit	Symbol	Description
[7:5]	-	Reserved
4	SENDOK	<b>SEND OK Interrupt</b> It is set by '1' after Sn_CR[SEND] complete.
3	TIMEOUT	<b>TIMEOUT Interrupt</b> When the count of retransmission exceeds Sn_RCR (SOCKET n Retransmission Count Register) in ARP/ND or TCP communication, it is set by '1'.
2	RECV	<b>RECEIVED Interrupt</b> When SOCKET received DATA or when DATA still remained in SOCKET n buffer block after Sn_CR[RECV], it is set by '1'.
1	DISCON	<b>DISCONNECTED Interrupt</b> When SOCKET received FIN or RST Packet or when SOCKET received ACK packet for FIN packet sent by Sn_CR[DISCON], it is set by '1'.
0	CON	<b>CONNECTED Interrupt</b> When TCP connection is established by Sn_CR[CONNECT], Sn_CR [CONNECT6] or by receiving SYN packet from destination, it is set by '1'.

## 4.2.5 Sn\_IMR (SOCKET n Interrupt Mask Register)

**[R=W] [0x0024] [0xFF]**

Sn\_IMR is used for the corresponding Sn\_IR bit mask.

7	6	5	4	3	2	1	0
-	-	-	SENDOK	TIMEOUT	RECV	DISCON	CON
			R=W	R=W	R=W	R=W	R=W

Bit	Symbol	Description
[7:5]	-	Reserved

4	SENDOK	Sn_IR[SENDOK] Interrupt Mask
3	TIMEOUT	Sn_IR[TIMEOUT] Interrupt Mask
2	RECV	Sn_IR[RECV] Interrupt Mask
1	DISCON	Sn_IR[DISCON] Interrupt Mask
0	CON	Sn_IR[CON] Interrupt Mask

#### 4.2.6 Sn\_IRCLR (Sn\_IR Clear Register)

**[WO] [0x0028] [0xFF]**

Sn\_IRCLR clears the corresponding Sn\_IR bit.

Bit	Symbol	Description
[7:5]	-	Reserved
4	SENDOK	Sn_IR[SENDOK] Interrupt Clear
3	TIMEOUT	Sn_IR[TIMEOUT] Interrupt Clear
2	RECV	Sn_IR[RECV] Interrupt Clear
1	DISCON	Sn_IR[DISCON] Interrupt Clear
0	CON	Sn_IR[CON] Interrupt Clear

#### 4.2.7 Sn\_SR (SOCKET n Status Register)

**[RO] [0x0030] [0x00]**

Sn\_SR describes the status of SOCKET n. The status of SOCKET n is changed by SOCKET n command or sent/received DATA.

Value	Symbol	Description
0x00	SOCK_CLOSED	SOCKET n closed.
0x13	SOCK_INIT	SOCKET n opened in TCP Mode.
0x14	SOCK_LISTEN	SOCKET n is in TCP Mode and waits for Connection request.
0x17	SOCK_ESTABLISHED	SOCKET n is in TCP Mode and TCP Connection is completed.
0x1C	SOCK_CLOSE_WAIT	SOCKET n is in TCP Mode and received FIN Packet.
0x22	SOCK_UDP	SOCKET n opened in UDP Mode.
0x32	SOCK_IPRAW	SOCKET n opened in IPRAW Mode.
0x33	SOCK_IPRAW6	SOCKET n opened in IPRAW6 Mode.
0x42	SOCK_MACRAW	SOCKET n opened in MACRAW Mode.

The below table shows the temporary status indicated during changing the status of SOCKET.

Value	Symbol	Description
0x15	SOCK_SYSENT	The status of sending Connect-Request.
0x16	SOCK_SYNRECV	The status of receiving Connect-Request.
0x18	SOCK_FIN_WAIT	The status of closing SOCKET n.
0X1B	SOCK_TIME_WAIT	
0X1D	SOCK_LAST_ACK	

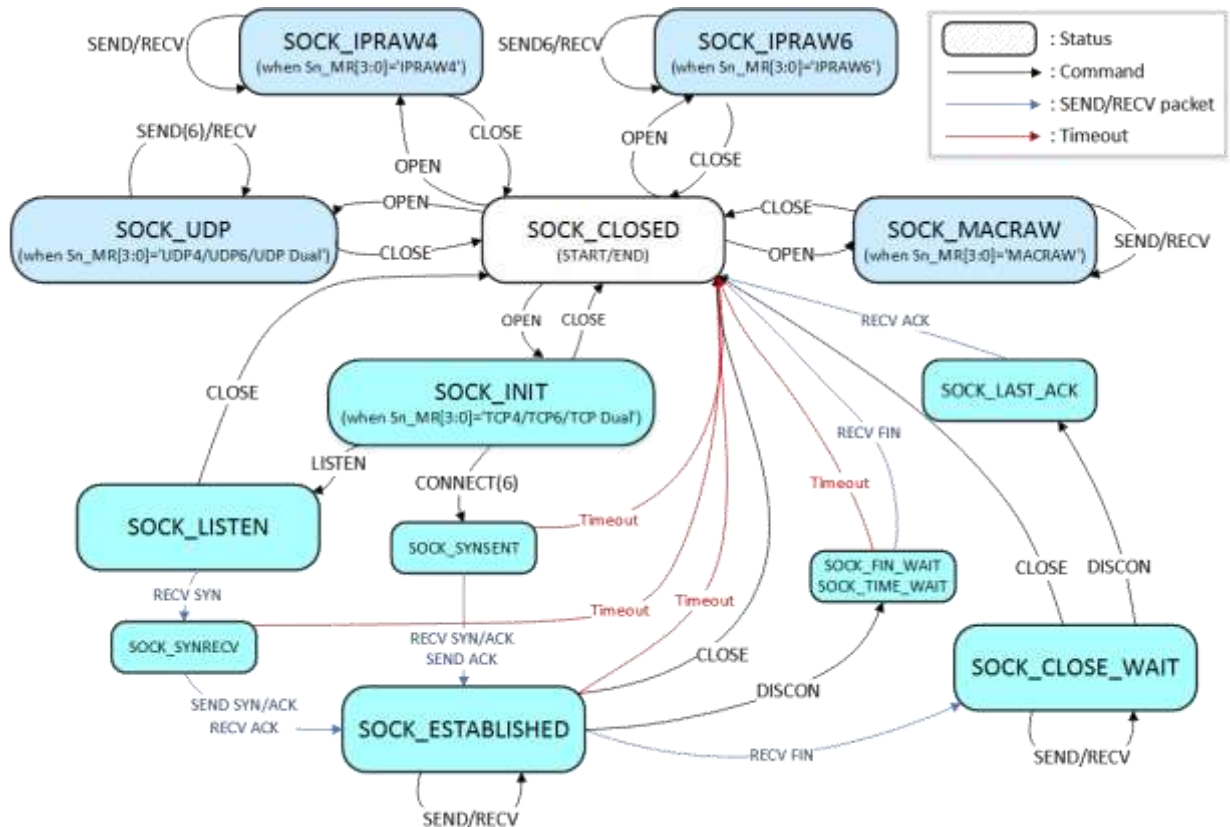

Figure 4 State Diagram

#### 4.2.8 Sn\_ESR (SOCKET n Extension Status Register)

[RO] [0x0031] [0x00]

Sn\_ESR indicates SOCKET n extension status in TCP4, TCP6 and TCPD mode.

7	6	5	4	3	2	1	0
-	-	-	-	-	TCPM	SVR	GUA
-	-	-	-	-	RO	RO	RO

Bit	Symbol	Description
[7:3]	-	Reserved
2	TCPM	TCP Mode

		It describes TCP version after connection with Destination in TCPD Mode.  0 : TCP4 1 : TCP6
1	TCPOP	<b>TCP Operation Mode</b> 0 : TCP Client 1 : TCP Server
0	IP6T	<b>IPv6 Address type</b> It describes Source IPv6 Address of the sent packet in TCP6 and TCPD Mode.  0 : LLA 1 : GUA

#### 4.2.9 Sn\_PNR (SOCKET n IP Protocol Number Register)

**[R=W] [0x0100] [0x0000]**

In IPRAW4 and IPRAW6 mode, Sn\_PNR sets upper layer protocol number of IPv4, or next header of IPv6. Please refer to [Table 7](#) and [IANA\\_Protocol Numbers](#) to set sn\_PNR.

DO NOT set as TCP(0x06) and UDP(0x11).

#### 4.2.10 Sn\_TOSR (SOCKET n IP Type of Service Register)

**[R=W] [0x0104] [0x00]**

Sn\_TOSR sets TOS (Type Of Service) of IPv4 header.

ref) [IANA\\_IP Parameters](#)

**\* CAUTION** W6100 does not support Traffic Class and Flow Label Field in IPv6 Header. Both will be fixed as '0'.

#### 4.2.11 Sn\_TTLR (SOCKET n IP Time To Live Register)

**[R=W] [0x0108] [0x80]**

Sn\_TTLR sets TTL(Time To Live) of IPv4 header, or HOP limit field in IPv6 header.

ref) [IANA\\_IP Parameters](#)

#### 4.2.12 Sn\_FRGR (SOCKET n Fragment Offset in IP Header Register)

**[R=W] [0x010C-0x010D] [0x4000]**

Sn\_FRGR sets Fragment Offset of IP Header.

\* **CAUTION** Fragment field can be set to any values. But W6100 SOCKET does not perform fragmentation and does not process any fragmented received packet.

Ex) S0\_FRGR0 = 0x0000 (DO NOT fragment)

S0_FRGR0(0x010C)	S0_FRGR1(0x010D)
0x00	0x00

#### 4.2.13 Sn\_MSSR (SOCKET n Maximum Segment Size Register)

[R=W] [0x0110-0x0111] [0xFFFF]

Sn\_MSSR sets SOCKET n MSS (Maximum Segment Size) and it must be done before Sn\_CR[OPEN]. Each SOCKET mode has the MSS range. And if SOCKET n MSS set by Sn\_MSSR exceeds the MSS range, it automatically sets the maximum MSS in the MSS range.

Sn_MR[3:0]	Normal Range (NETMR2[PPPoE]='0')	PPPoE Range (NETMR2[PPPoE]='1')
TCP	1-1460	1-1452
TCP6	1-1440	1-1432
UDP	1-1472	1-1464
UDP6	1-1452	1-1444
IPRAW	1-1480	1-1472
IPRAW6	1-1460	1-1452
MACRAW	1-1514	

Ex) S0\_MSSR = 1460 (0x05B4),

S0_MSSR0(0x0110)	S0_MSSR1(0x0111)
0x05	0xB4

#### 4.2.14 Sn\_PORTR (SOCKET n Source Port Register)

[R=W] [0x0114-0x0115] [0x0000]

Sn\_PORTR sets SOCKET n Source Port Number.

Ex) S0\_PORTR = 5000 (0x1388)

S0_PORTR0(0x0114)	S0_PORTR1(0x0115)
0x013	0x88

#### 4.2.15 Sn\_DHAR (SOCKET n Destination Hardware Address Register)

**[RW] [0x0118-0x11D] [0x0000\_0000\_0000]**

Sn\_DHAR indicates the destination hardware address after the connection is established (Sn\_SR = SOCK\_ESTABLISHED) with the destination in TCP4, TCP6, TCPD mode.

Sn\_DHAR is set as multicast group hardware address when Sn\_MR[3:0] is UDP4 or UDP6 and Sn\_MR[MULTI] is '1'.

*ref) 6.3.3 UDP Multicast*

Ex) SO\_DHAR = "11:22:33:AA:BB:CC"

SO_DHAR0(0x0118)	SO_DHAR1(0x0119)	SO_DHAR2(0x011A)
0x11	0x22	0x33
SO_DHAR3(0x011B)	SO_DHAR4(0x011C)	SO_DHAR5(0x011D)
0xAA	0xBB	0xCC

#### 4.2.16 Sn\_DIPR (SOCKET n Destination IPv4 Address Register)

**[RW] [0x0120-0x0123] [0x0000\_0000]**

Sn\_DIPR indicates IPv4 destination address and depends on the protocol type in Sn\_MR[3:0].

Sn_MR[3:0]	Sn_MR[MULTI]	Sn_DIPR
TCP4	Don't care	Set or Get Destination IPv4 Address
TCPD	Don't care	
UDP4	0	Set Destination IPv4 Address
UDP6	Don't care	
IPRAW4	Don't care	
UDP4	1	Set Multicast Group IPv4 Address

*ref) 6.3.3 UDP Multicast*

Ex) SO\_DIPR = "192.168.0.11"

SO_DIPR0(0x0120)	SO_DIPR1(0x0121)	SO_DIPR2(0x0122)	SO_DIPR3(0x0123)
192 (0xC0)	168 (0xA8)	0 (0x00)	11 (0x0B)

#### 4.2.17 Sn\_DIP6R (SOCKET n Destination IPv6 Address Register)

**[RW] [0x0130-0x013F] [0x0000\_0000\_0000\_0000\_0000\_0000\_0000\_0000]**

Sn\_DIPR indicates IPv6 destination address and depends on the protocol type in Sn\_MR[3:0].

Sn_MR[3:0]	Sn_MR[MULTI]	Sn_DIP6R
TCP6	Don't care	Set or Get Destination IPv6 Address
TCPD	Don't care	
UDP6	0	Set Destination IPv6 Address
UDP6	0	
UDP6	0	
IPRAW6	Don't care	Set Multicast Group IPv6 Address
UDP6	1	

ref) 6.3.3 UDP Multicast

Ex) Destination IP is "FE80::AB:CDEF"

S0_DIP6R0(0x0130)	S0_DIP6R1(0x0131)	S0_DIP6R2(0x0132)	S0_DIP6R3(0x0133)
0xFE	0x80	0x00	0x00
S0_DIP6R4(0x0134)	S0_DIP6R5(0x0135)	S0_DIP6R6(0x0136)	S0_DIP6R7(0x0137)
0x00	0x00	0x00	0x00
S0_DIP6R8(0x0138)	S0_DIP6R9(0x0139)	S0_DIP6R10(0x013A)	S0_DIP6R11(0x013B)
0x00	0x00	0x00	0x00
S0_DIP6R12(0x013C)	S0_DIP6R13(0x013D)	S0_DIP6R14(0x013E)	S0_DIP6R15(0x013F)
0x00	0xAB	0xCD	0xEF

#### 4.2.18 Sn\_DPORTR (SOCKET n Destination Port Register)

[R=W] [0x0140-0x0141] [0x0000]

Sn\_DPORTR indicates destination port and depends on the protocol type in Sn\_MR[3:0].

Sn_MR[3:0]	Sn_MR[MULTI]	Sn_DPORTR
TCP4	Don't care	Set or Get Destination Port
TCP6	Don't care	
TCPD	Don't care	
UDP4	0	Set Destination Port
UDP6	0	
UDP6	0	
UDP6	0	
IPRAW4	Don't care	Set Multicast Group Port
IPRAW6	Don't care	
UDP4	1	Set Multicast Group Port
UDP6	1	

In TCP4, TCP6 and TCPD mode, Sn\_DPORTR is set to the destination port or get the connected destination port.

In UDP4, UDP6, UDPD and IPRAW6 mode, Sn\_DPORTR is set to the peer's destination port.

In UDP4 and UDP6 multicast mode, Sn\_DPORTR is set to the multicast group port.

ref) [6.3.3 UDP Multicast](#)

Ex) SO\_DPORTR = 5000 (0x1388),

SO_DPORTR0(0x0140)	SO_DPORTR1(0x0141)
0x13	0x88

#### 4.2.19 Sn\_MR2 (SOCKET n Mode register 2)

[R=W] [0x0144] [0x00]

Sn\_MR2 sets SOCKET n option like Sn\_MR.

7	6	5	4	3	2	1	0
	-	-	-	-	-	DHAM	FARP
						R=W	R=W

Bit	Symbol	Description
[7:2]	-	Reserved
1	DHAM	<p><b>Destination Hardware address Mode</b></p> <p>It sets destination hardware address of Ethernet frame to be sent when Sn_MR[3:0] is not MACRAW mode.</p> <p>0 : Destination hardware address is set to the address obtained through ARP-process.</p> <p>1 : Destination hardware address is set to the value in Sn_DHAR.</p>
0	FARP	<p><b>Force ARP</b></p> <p>When Sn_MR is UDP4, UDP6, UDPD, IPRAW4 and IPRAW6 mode, SOCKET n performs ARP/ND-process on every Sn_CR[SEND] or Sn_CR[SEND6].</p> <p>When Sn_MR is TCP4, TCP6, TCPD and the TCP operation mode is "TCP SERVER", the ARP/ND-process is performed before sending the SYN/ACK packet.</p> <p>The destination hardware address obtained by ARP-process is used as destination hardware address of packet to be sent.</p> <p>0 : Disable</p> <p>1 : Enable</p>

---

**\* CAUTION** In case of DHAM = '1', Even if ARP/ND-process performs, the destination hardware address is set as Sn\_DHAR.

---

#### 4.2.20 Sn\_RTR (SOCKET n Retransmission Time Register)

**[R=W] [0x0180-0x0181] [0x0000]**

Sn\_RTR sets SOCKET n retransmission time and the unit is 100us. If Sn\_RTR is '0', it is initialized by Sn\_CR[OPEN] = '1' with the value of RTR.

Refer to [6.7 Retransmission](#).

Ex) S0\_RTR = 5000 (0x1388),

$$5000 * 100\mu s = 0.5s$$

S0_RTR0(x0180)	S0_RTR1(0x0181)
0x013	0x88

#### 4.2.21 Sn\_RCR (SOCKET n Retransmission Count Register)

**[R=W] [0x0184] [0x00]**

Sn\_RCR sets SOCKET n retransmission counter. If Sn\_RCR is '0', it is initialized by Sn\_CR[OPEN] = '1' with the value of RCR.

Refer to [6.7 Retransmission](#).

#### 4.2.22 Sn\_KPALVTR (SOCKET n Keep Alive Time Register)

**[R=W] [0x0188] [0x00]**

Sn\_KPALVTR sets SOCKET n TCP Keep Alive (KA) time and the unit is 5 sec. When Sn\_SR is SOCK\_ESTABLISHED and SOCKET n sent over 1 Byte DATA, SOCKET n is valid to send KA packet. If Sn\_KPALVRT is '0', SOCKET n only sends KA packet by Sn\_CR[SENDKEEP].

Ex) S0\_KPALVTR = 10 (0x0A),

$$10 * 5s = 50s$$

S0_KPALVTR(0x0188)
0x0A

#### 4.2.23 Sn\_TX\_BSR (SOCKET n TX Buffer Size Register)

**[R=W] [0x0200] [0x02]**

Sn\_TX\_BSR sets SOCKET n TX Buffer size to 0, 1, 2, 4, 8 or 16KB.

If it sets to the other value or the total size of Sn\_TX\_BSR exceeds 16KB, it causes a malfunction in buffer read/write access process.

Value (Dec)	0	1	2	4	8	16
Buffer size	0KB	1KB	2KB	4KB	8KB	16KB

Ex) S0\_TX\_BSR= 4 Kbytes

S0_TX_BSR(0x0200)
0x04

#### 4.2.24 Sn\_TX\_FSR (SOCKET n TX Free Buffer Size Register)

**[RO] [0x0204-0x205] [0x0000]**

Sn\_TX\_FSR indicates the free size in SOCKET n buffer block.

In UDP, IPRAW and MACRAW mode,  
 $Sn\_TX\_FSR = Sn\_TX\_BSR - | Sn\_TX\_WR^{(1)} - Sn\_TX\_RD^{(2)} |$

In TCP mode,  
 $Sn\_TX\_FSR = Sn\_TX\_BSR - | Sn\_TX\_WR - Internal\ Pointer^{(3)} |$

(1) SOCKET n TX Write Pointer Register  
 (2) SOCKET n TX Read Pointer Register  
 (3) TCP ACK Pointer managed by W6100

Make sure sending DATA size does not exceed the size in sn\_TX\_FSR.

Ex) S0\_TX\_FSR = 1024 (0x0400)

S0_TX_FSR0(0x0204)	S0_TX_FSR1(0x0205)
0x04	0x00

#### 4.2.25 Sn\_TX\_RD (SOCKET n TX Read Pointer Register)

**[RO] [0x0208-0x0209] [0x0000]**

Sn\_TX\_RD is initialized by Sn\_CR[OPEN].

By Sn\_CR [SEND], SOCKET sends DATA, which is stored from Sn\_TX\_RD to Sn\_TX\_WR in SOCKET n TX Buffer. After sending DATA, Sn\_IR [SENDOK] is set and Sn\_TX\_RD is automatically increased by sent data size. If the auto-increment Sn\_TX\_RD exceeds the maximum value 0xFFFF of the 16-bit offset address and the Carry bit (17<sup>th</sup> bit) occurs, the carry bit is ignored and automatically set to the lower 16 bits value.

Ex) S0\_TX\_RD = 0xd4b3

S0_TX_RD0(0x0208)	S0_TX_RD1(0x0209)
0xd4	0xb3

#### 4.2.26 Sn\_TX\_WR (SOCKET n TX Write Pointer Register)

**[RW] [0x020C-0x20D] [0x0000]**

Sn\_TX\_WR is initialized by Sn\_CR[OPEN].

To send DATA, Sn\_TX\_WR is processed as the following procedure.

1. HOST reads the start address to store the sending DATA from Sn\_TX\_WR.
2. HOST stores the sending DATA from the start address in SOCKET n TX buffer.
3. HOST increases Sn\_TX\_WR by the size of the sending DATA. If the value of Sn\_TX\_WR exceeds 0xFFFF(the maximum value of 16bits Offset Address), the carry bit(17<sup>th</sup> bit) will be ignored and the value of Sn\_TX\_WR must be set to the lower 16bits Offset Address.
4. HOST sets Sn\_CR[SEND] to send the stored DATA in SOCKET n TX buffer.

Ex) S0\_TX\_WR = 0x0800

S0_TX_WR0(0x020C)	S0_TX_WR1(0x020D)
0x08	0x00

#### 4.2.27 Sn\_RX\_BSR (SOCKET n RX Buffer Size Register)

**[R=W] [0x0220] [0x02]**

Sn\_RX\_BSR sets SOCKET n RX Buffer Size to 0, 1, 2, 4, 8 or 16 KB.

If the total size of SOCKET n RX buffer exceeds 16KB, it causes a malfunction in buffer read/write access process.

Value (Dec)	0	1	2	4	8	16
Buffer size	0KB	1KB	2KB	4KB	8KB	16KB

Ex) S0\_RX\_BSR = 8 Kbytes

S0_RX_BSR(0x0220)
0x08

#### 4.2.28 Sn\_RX\_RSR (SOCKET n RX Received Size Register)

**[RO] [0x0224-0x0225] [0x0000]**

Sn\_RX\_RSR indicates the size of received DATA in SOCKET n RX buffer.

In TCP, UDP, IPRAW and MACRAW mode,

$$\text{Sn\_RX\_RSR} = |\text{Sn\_RX\_WR}^{(1)} - \text{Sn\_RX\_RD}^{(2)}|$$

(1) SOCKET n RX Write Pointer Register

(2) SOCKET n RX Read Pointer Register

Ex) S0\_RX\_RSR = 2048 (0x0800)

SO_RX_RSR0(0x0224)	SO_RX_RSR1(0x0225)
0x08	0x00

#### 4.2.29 Sn\_RX\_RD (SOCKET n RX Read Pointer Register)

**[RW] [0x0228-0x0229] [0x0000]**

Sn\_RX\_RD is initialized by Sn\_CR[OPEN]. The received DATA in SOCKET n RX buffer is read or updated as the following procedure.

1. HOST reads the start address of the received DATA from Sn\_RX\_RD in SOCKET n RX buffer.
2. HOST reads the received DATA from the start address.
3. HOST increases Sn\_RX\_RD by the read DATA size. If the value of increasing Sn\_RX\_RD exceeds 0xFFFF(the maximum value of 16bits offset address), the carry bit(17<sup>th</sup> bit) will be ignored and the value of Sn\_RX\_RD must be set to the lower 16bits offset address.
4. HOST sets Sn\_CR[RCV] to free SOCKET n RX buffer up by the size of DATA read.

Ex) SO\_RX\_RD =1536(0x0600)

SO_RX_RD0(0x0228)	SO_RX_RD1(0x0229)
0x06	0x00

#### 4.2.30 Sn\_RX\_WR (SOCKET n RX Write Pointer Register)

**[RO] [0x022C-0x022D] [0x0000]**

Sn\_RX\_WR indicates the last address of the received DATA in SOCKET n TX buffer block. Sn\_RX\_WR is initialized by Sn\_CR [OPEN] and automatically increased by received DATA size. If the incremented Sn\_RX\_WR exceeds the maximum value 0xFFFF of the 16-bit offset address and the carry bit (17<sup>th</sup> bit) occurs, the carry bit is ignored and automatically set to the lower 16 bits value.

Ex) SO\_RX\_WR = 1536(0x0600)

SO_RX_WR0(0x022C)	SO_RX_WR1(0x022D)
0x06	0x00

## 5. HOST Interface Mode

For the communication with HOST, W6100 supports SPI(Serial peripheral Interface) and Parallel BUS I/F. By MOD[3:0].

SPI BUS consists of CSn, SCLK, MOSI and MISO and parallel BUS consists control signal (CSn, WRn, RDn,INTn) , address(2bits) and data bits(8bits).

### 5.1 SPI Mode

In case where MOD[3:0] is set to '000X' , SPI mode is activated and it operates as SPI slave mode. W6100 can be connected to HOST as shown [Figure 5](#) and [Figure 6](#)in according to its SPI operation mode('5.1.2 Variable Length Data Mode (VDM)' and '5.1.3 Fixed Length Data Mode (FDM)'). [Figure 5](#) shows that SPI BUS is shared with other SPI slaves according to the selection of SPI master but [Figure 6](#) shows that it doesn't share SPI BUS with other SPI slaves and HOST is connected to only W6100.

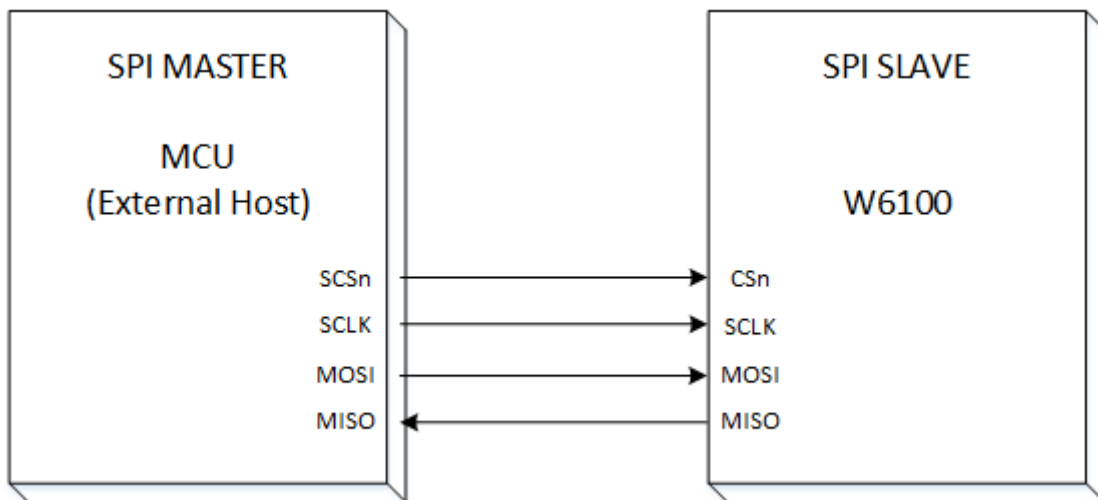

Figure 5 Variable Length Data Mode (CSn controlled by HOST)

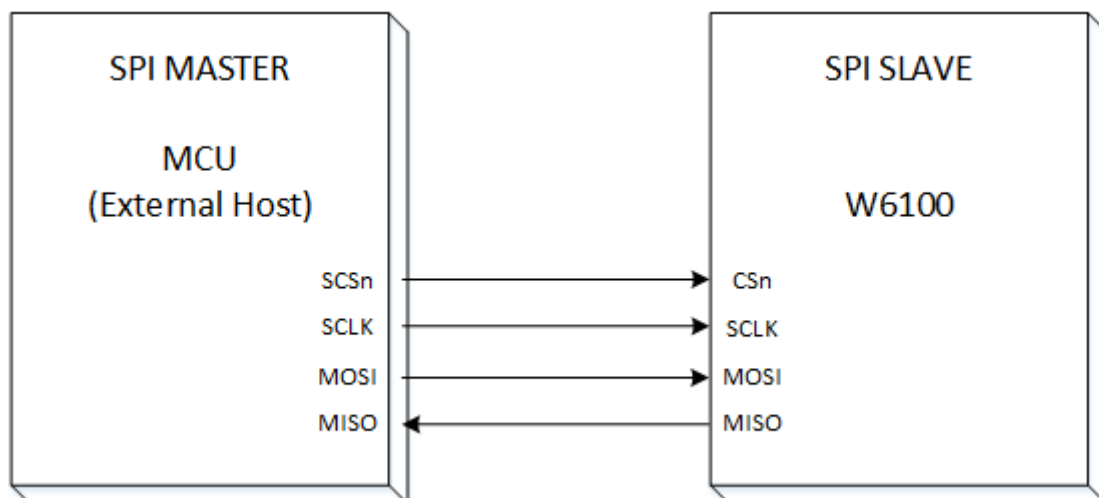

Figure 6 Fixed Length Data Mode (CSn is always connected by Ground)

W6100 supports SPI mode 0 and mode 3 as shown in Figure 7 below.

Data is always sampling on the rising edge of SCLK and toggling on the falling edge of SCLK.

MOSI & MISO signals always transmit or receive in sequence from MSB to LSB every SCLK.

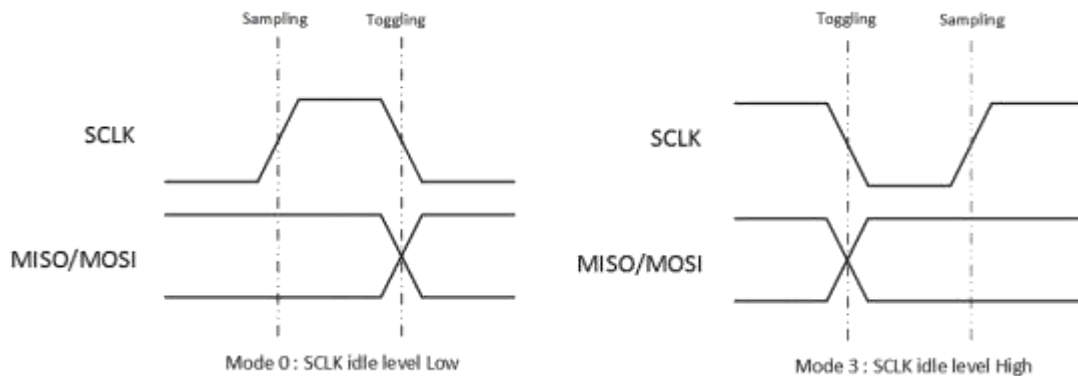

Figure 7 SPI Mode 0 & Mode 3

### 5.1.1 SPI Frame

W6100 communicates with HOST in SPI frame and SPI frame consists address phase, control phase, and data phase as shown in Figure 8 below.

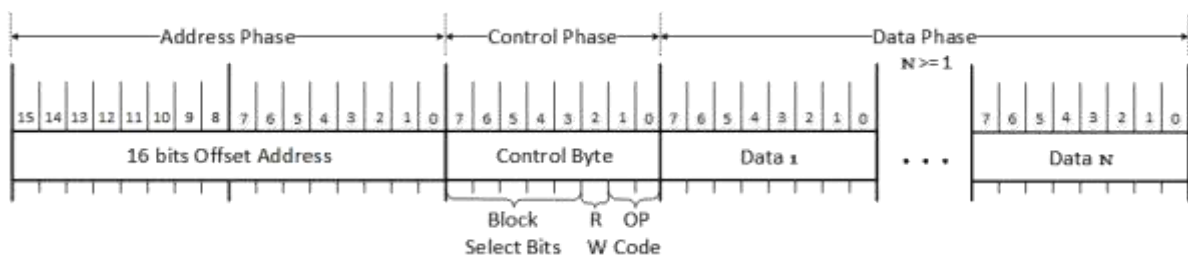

Figure 8 SPI Frame Format

Address phase indicates 16bits offset address for W6100 register or TX/RX buffer. Control phase indicates which block is selected, R/W access mode and SPI operation mode (VDM, FDM). Data phase differs 1, 2, 4, N bytes by SPI operation mode.

When the SPI operation mode is Variable length Data Mode (VDM), CSn signal must be controlled by the HOST. In the VDM, SPI frame starts by CSn transition (High -to -Low) of HOST and ends by CSn transition (Low-to-High).

In brief, VDM is controlled by CSn and length is not limited. In FDM, the CSn value is fixed to '0' and data transmits 1,2,4 bytes by SPI operation mode.

### 5.1.1.1 Address Phase

Address phase indicates 16bits offset address of W6100 common register, SOCKET registers and SOCKET n TX/RX buffer block.

The 16bits offset address is transferred from MSB to LSB sequentially.

W6100 SPI BUS interface supports sequential data read/write which offsets the address automatically and increases by 1 after every 1byte read or write.

### 5.1.1.2 Control Phase

Control phase indicates the block to which the offset address in address phase belongs and shows R/W access mode (RWB) and SPI operation mode (OM[1:0]).

7	6	5	4	3	2	1	0
BSB4	BSB3	BSB2	BSB1	BSB0	RWB	OM1	OM0

Bit	Symbol	Description																																
7-3	BSB	<p><b>Block Selection Bits</b></p> <p>W6100 has 1 common register, 8 SOCKET n register and TX/RX buffer block for each SOCKET.</p> <p>The block is selected by BSB[4:0] as shown in the table below.</p> <p>The most significant three bits indicates SOCKET which is from 0 to 7.</p> <p>The least significant two bits indicate what kind of subblocks are in the SOCKET block.</p>																																
		<table border="1"> <thead> <tr> <th>BSB[4:2]</th> <th>BSB[1:0]</th> <th>Block</th> </tr> </thead> <tbody> <tr> <td rowspan="4" style="text-align: center;">000</td> <td style="text-align: center;">00</td> <td>Common Register</td> </tr> <tr> <td style="text-align: center;">01</td> <td>SOCKET 0 Register</td> </tr> <tr> <td style="text-align: center;">10</td> <td>SOCKET 0 TX Buffer</td> </tr> <tr> <td style="text-align: center;">11</td> <td>SOCKET 0 RX Buffer</td> </tr> <tr> <td rowspan="4" style="text-align: center;">001</td> <td style="text-align: center;">00</td> <td>Reserved</td> </tr> <tr> <td style="text-align: center;">01</td> <td>SOCKET 1 Register</td> </tr> <tr> <td style="text-align: center;">10</td> <td>SOCKET 1 TX Buffer</td> </tr> <tr> <td style="text-align: center;">11</td> <td>SOCKET 1 RX Buffer</td> </tr> <tr> <td rowspan="4" style="text-align: center;">010</td> <td style="text-align: center;">00</td> <td>Reserved</td> </tr> <tr> <td style="text-align: center;">01</td> <td>SOCKET 2 Register</td> </tr> <tr> <td style="text-align: center;">10</td> <td>SOCKET 2 TX Buffer</td> </tr> <tr> <td style="text-align: center;">11</td> <td>SOCKET 2 RX Buffer</td> </tr> <tr> <td colspan="2" style="text-align: center;">                     .                      .                      .                 </td> </tr> </tbody> </table>	BSB[4:2]	BSB[1:0]	Block	000	00	Common Register	01	SOCKET 0 Register	10	SOCKET 0 TX Buffer	11	SOCKET 0 RX Buffer	001	00	Reserved	01	SOCKET 1 Register	10	SOCKET 1 TX Buffer	11	SOCKET 1 RX Buffer	010	00	Reserved	01	SOCKET 2 Register	10	SOCKET 2 TX Buffer	11	SOCKET 2 RX Buffer	. . .	
		BSB[4:2]	BSB[1:0]	Block																														
		000	00	Common Register																														
			01	SOCKET 0 Register																														
			10	SOCKET 0 TX Buffer																														
			11	SOCKET 0 RX Buffer																														
		001	00	Reserved																														
			01	SOCKET 1 Register																														
			10	SOCKET 1 TX Buffer																														
			11	SOCKET 1 RX Buffer																														
		010	00	Reserved																														
01	SOCKET 2 Register																																	
10	SOCKET 2 TX Buffer																																	
11	SOCKET 2 RX Buffer																																	
. . .																																		

		<table border="1"> <tr> <td>00</td> <td>Reserved</td> </tr> <tr> <td>01</td> <td>SOCKET 7 Register</td> </tr> <tr> <td>10</td> <td>SOCKET 7 TX Buffer</td> </tr> <tr> <td>11</td> <td>SOCKET 7 RX Buffer</td> </tr> </table> <p>For example, if SOCKET 2 register block is indicated, it is BSB[4:2] = '010' and BSB[1:0] = '01'</p>	00	Reserved	01	SOCKET 7 Register	10	SOCKET 7 TX Buffer	11	SOCKET 7 RX Buffer		
00	Reserved											
01	SOCKET 7 Register											
10	SOCKET 7 TX Buffer											
11	SOCKET 7 RX Buffer											
2	RWB	<p><b>Read/Write Access Mode Bit</b></p> <p>This bit sets SPI access mode</p> <p>0 : Read</p> <p>1 : Write</p>										
1~0	OM[1:0]	<p><b>SPI Operation Mode Bits</b></p> <p>This bit sets SPI operation mode. SPI operation mode supports variable length data mode(VDM) and fixed length data mode(FDM).</p> <table border="1"> <thead> <tr> <th>OM[1:0]</th> <th>Mode</th> </tr> </thead> <tbody> <tr> <td>00</td> <td>VDM, N bytes Data Phase (1 ≤ N)</td> </tr> <tr> <td>01</td> <td>FDM, 1 byte Data Phase</td> </tr> <tr> <td>10</td> <td>FDM, 2 bytes Data Phase</td> </tr> <tr> <td>11</td> <td>FDM, 4 bytes Data Phase</td> </tr> </tbody> </table> <p><b>Variable Length Data Mode (VDM)</b></p> <p>Data phase is valid while CSn is LOW and N-byte data can be transmitted in data phase. When CSn turns to HIGH, data phase terminates.</p> <p>HOST should make CSn signal assert(High-to-Low) to inform the start of the SPI frame to W6100.</p> <p>Then it should transfer the control phase with OM[1:0] = '00' to inform that it works as VDM.</p> <p>After N-bytes data phase, HOST should De-assert (Low-to-High) CSn to inform the end of SPI frame to W6100.</p> <p>In VDM mode, the CSn must be controlled by SPI frame unit by HOST</p> <p><b>Fixed Length Data Mode (FDM)</b></p> <p>In FDM mode, the data length is designated by OM[1:0] and it should not be '00'.</p> <p>CSn signal should be tied to GND.</p> <p>W6100 processes data during the length which is designated in the OM[1:0] value.</p>	OM[1:0]	Mode	00	VDM, N bytes Data Phase (1 ≤ N)	01	FDM, 1 byte Data Phase	10	FDM, 2 bytes Data Phase	11	FDM, 4 bytes Data Phase
OM[1:0]	Mode											
00	VDM, N bytes Data Phase (1 ≤ N)											
01	FDM, 1 byte Data Phase											
10	FDM, 2 bytes Data Phase											
11	FDM, 4 bytes Data Phase											

### 5.1.1.3 Data Phase

The length of data phase is selected among N-byte(VDM) or 1,2,4 bytes(FDM) which is designated in SPI operation mode bits(OM[1:0]) of control phase. Data is transferred through MOSI or MISO signal from MSB to LSB sequentially.

### 5.1.2 Variable Length Data Mode (VDM)

In this mode, the data phase length of SPI Frame is determined by CSn which is controlled by the HOST.

The OM[1:0] of control phase must be set to '00' value for VDM mode

#### 5.1.2.1 Write Access in VDM

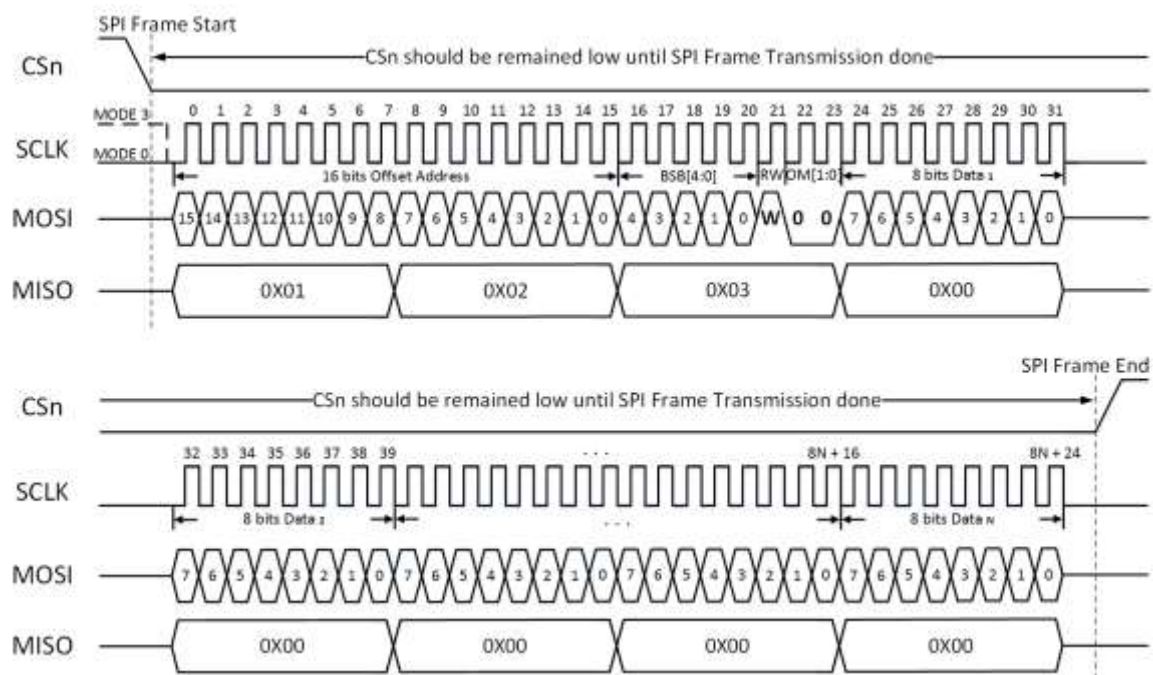

Figure 9 Write SPI Frame in VDM

Figure 9 shows the SPI frame and SPI signals in write access.

In the VDM, CSn(High-to-Low) by HOST informs the start of SPI frame and CSn(Low to High) by HOST informs the end of SPI Frame to W6100.

In the control phase, RWB is "1" to indicate write access and OM[1:0] is "00" to indicate VDM.

The data bits transmitted through MOSI are synchronized to the SCLK (Falling-Edge).

If more than one byte of data is transmitted continuously, it supports sequential data write.

### 5.1.2.2 Read Access in VDM

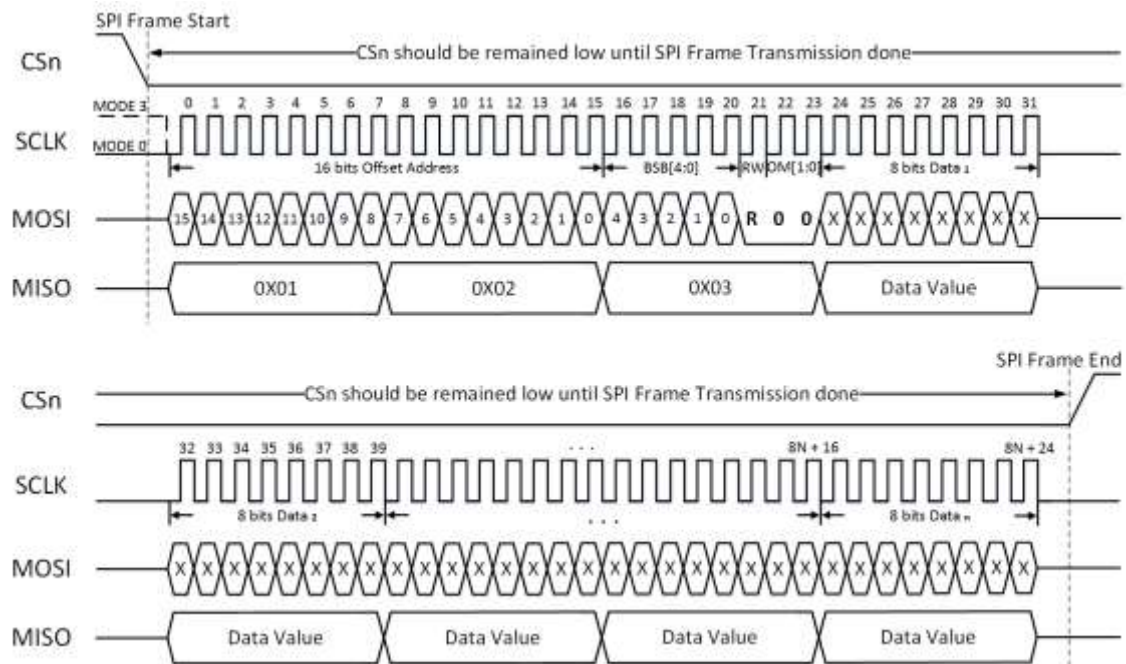

Figure 10 Read SPI Frame in VDM

Figure 10 shows the SPI Frame and SPI signals in Read Access.

In the VDM, CSn(High-to-Low) by HOST informs the start of SPI frame and CSn(Low to High) by HOST informs the end of SPI frame to W6100.

In the control phase, RWB is "0" to indicate read access and OM[1:0] is "00" to indicate VDM.

The data bits received through MISO are synchronized to SCLK (Falling-Edge).

If more than one byte of data is transmitted continuously, it supports sequential data write.

### 5.1.3 Fixed Length Data Mode (FDM)

In FDM operation, HOST doesn't control CSn and CSn is tied to GND.

Data phase length is selected by SPI operation mode Bits(OM[1:0]) in control phase and it is one of 1,2& 4 bytes.

When OM and transmitted data length are different W6100 may operate abnormally.

Regarding waveform of FDM, refer to [5.1.2 Variable Length Data Mode \(VDM\)](#).

### 5.1.3.1 Write Access in FDM

#### 1 byte Write Access

Address Phase																Control Phase						Data Phase									
																BSB				R/W	OM	1 <sup>st</sup> Data									
15	14	13	12	11	10	9	8	7	6	5	4	3	2	1	0	4	3	2	1	0	R/W	1	0	7	6	5	4	3	2	1	0
x	x	x	x	x	x	x	x	x	x	x	x	x	x	x	x	x	x	x	x	x	1	0	1	x	x	x	x	x	x	x	x

Figure 11 1 byte Data Write Access SPI Frame in FDM

#### 2 bytes Write Access

Address Phase																Control Phase						Data Phase									
																BSB				R/W	OM	1 <sup>st</sup> Data									
15	14	13	12	11	10	9	8	7	6	5	4	3	2	1	0	4	3	2	1	0	R/W	1	0	7	6	5	4	3	2	1	0
x	x	x	x	x	x	x	x	x	x	x	x	x	x	x	x	x	x	x	x	x	1	1	0	x	x	x	x	x	x	x	x

Data Phase							
2 <sup>nd</sup> Data							
7	6	5	4	3	2	1	0
x	x	x	x	x	x	x	x

Figure 12 2 bytes Data Write Access SPI Frame in FDM

#### 4 bytes Write Access

Address Phase																Control Phase						Data Phase									
																BSB				R/W	OM	1 <sup>st</sup> Data									
15	14	13	12	11	10	9	8	7	6	5	4	3	2	1	0	4	3	2	1	0	R/W	1	0	7	6	5	4	3	2	1	0
x	x	x	x	x	x	x	x	x	x	x	x	x	x	x	x	x	x	x	x	x	1	1	1	x	x	x	x	x	x	x	x

Data Phase								Data Phase								Data Phase							
2 <sup>nd</sup> Data								3 <sup>rd</sup> Data								4 <sup>th</sup> Data							
7	6	5	4	3	2	1	0	7	6	5	4	3	2	1	0	7	6	5	4	3	2	1	0
x	x	x	x	x	x	x	x	x	x	x	x	x	x	x	x	x	x	x	x	x	x	x	x

Figure 13 4 bytes Data Write Access SPI Frame in FDM

### 5.1.3.2 Read Access in FDM

#### 1 byte Read Access

Address Phase																Control Phase						Data Phase									
																BSB				RWB	OM	1 <sup>st</sup> Data									
15	14	13	12	11	10	9	8	7	6	5	4	3	2	1	0	4	3	2	1	0	R/W	1	0	7	6	5	4	3	2	1	0
x	x	x	x	x	x	x	x	x	x	x	x	x	x	x	x	x	x	x	x	x	0	0	1								
																								x	x	x	x	x	x	x	x

Figure 14 1byte Data Read Access SPI Frame in FDM

#### 2 bytes Read Access

Address Phase																Control Phase						Data Phase									
																BSB				RWB	OM	1 <sup>st</sup> Data									
15	14	13	12	11	10	9	8	7	6	5	4	3	2	1	0	4	3	2	1	0	R/W	1	0	7	6	5	4	3	2	1	0
x	x	x	x	x	x	x	x	x	x	x	x	x	x	x	x	x	x	x	x	x	0	1	0								
																								x	x	x	x	x	x	x	x

Data Phase							
2 <sup>nd</sup> Data							
7	6	5	4	3	2	1	0
x	x	x	x	x	x	x	x

Figure 15 2 bytes Data Read Access SPI Frame in FDM

#### 4 bytes Read Access

Address Phase																Control Phase						Data Phase									
																BSB				RWB	OM	1 <sup>st</sup> Data									
15	14	13	12	11	10	9	8	7	6	5	4	3	2	1	0	4	3	2	1	0	R/W	1	0	7	6	5	4	3	2	1	0
x	x	x	x	x	x	x	x	x	x	x	x	x	x	x	x	x	x	x	x	x	0	1	1								
																								x	x	x	x	x	x	x	x

Data Phase								Data Phase								Data Phase							
2 <sup>nd</sup> Data								3 <sup>rd</sup> Data								4 <sup>th</sup> Data							
7	6	5	4	3	2	1	0	7	6	5	4	3	2	1	0	7	6	5	4	3	2	1	0
x	x	x	x	x	x	x	x	x	x	x	x	x	x	x	x	x	x	x	x	x	x	x	x

Figure 16 4 bytes Data Read Access SPI Frame in FDM

## 5.2 Parallel BUS Mode

If the Pin MOD[3:0] is set to '010X', W6100 operates as parallel BUS mode. HOST and W6100 are connected as shown Figure 17 below.

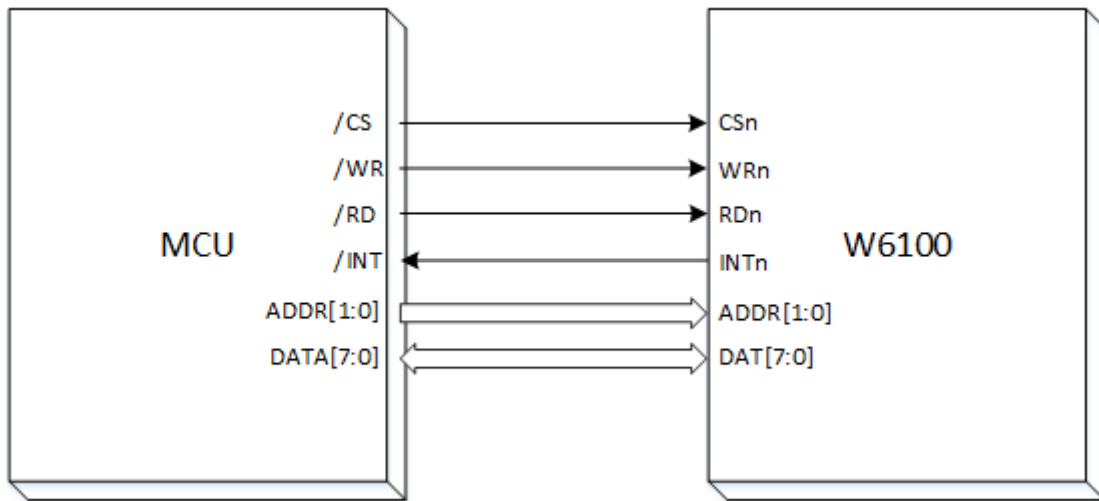

Figure 17 HOST Interface in Parallel BUS Mode

In Parallel BUS mode, HOST can access the below registers through BUS control signals such as ADDR[1:0], DAT[7:0], CSn, RDn, and WRn.

Like as SPI Frame, HOST can indirectly read/write a register of W6100 through these registers.

Table 3 Parallel Mode Address Value

ADDR[1:0]	Symbol	Description			
00	IDM_ARH	<b>Indirect Mode High Address Register</b> It is most significant byte of the 16bit offset address			
01	IDM_ARL	<b>Indirect Mode Low Address Register</b> It is least significant byte of the 16bit offset address			
10	IDM_BSR	<b>Indirect Mode Block Select Register</b> It can select to the block such as below.			

			10		SOCKET 2 TX Buffer
			11		SOCKET 2 RX Buffer
				⋮	
			00	Reserved	Reserved
		111	01		SOCKET 7 Register
			10		SOCKET 7 TX Buffer
			11		SOCKET 7 RX Buffer
11	IDM_DR	<b>Indirect Mode Data Register</b>			
		Data			

### 5.2.1 Parallel BUS Data Write

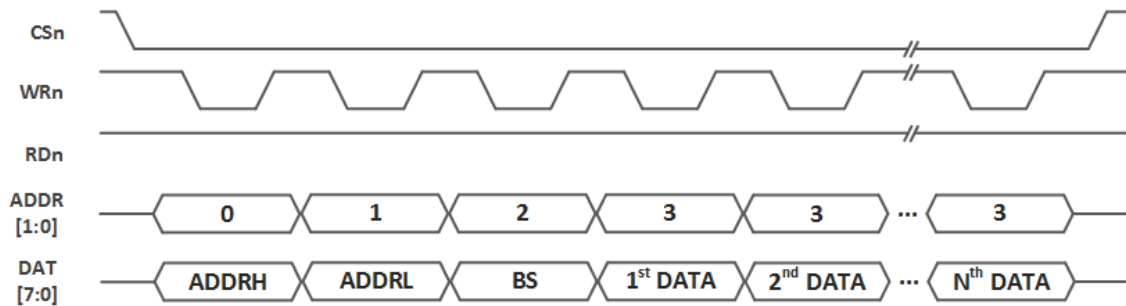

Figure 18 Parallel BUS N-Bytes Data Write Access

Figure 18 shows N-Byte data write through parallel BUS. HOST asserts CSn to LOW during N-bytes data transmission and if it is done, HOST de-asserts CSn to HIGH.

In write access, HOST should toggle WRn every BUS transition.

HOST transmits '00' on ADDR[1:0] to indicate that ADDRH is on DAT[7:0], and then '01' on ADDR[1:0] & ADDRl on DAT[7:0], '10' on ADDR[1:0] & BS on DAT[7:0], '11' on ADDR[1:0] & DATA on DAT[7:0].

If there are more than one byte DATA, '11' on ADDR[1:0] and a DATA on DAT[7:0] can be followed continuously.

## 5.2.2 Parallel BUS Data Read

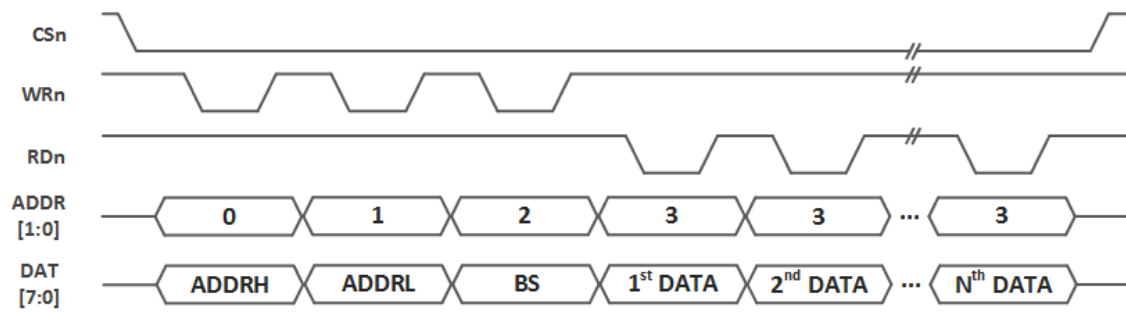

Figure 19 Parallel Mode Continuous Read Access

Figure 19 shows N-Byte data read through parallel BUS. HOST asserts CSn to LOW during N-bytes data read and if it is done, HOST de-asserts CSn to HIGH.

In read access, HOST should toggle WRn for controlling BUS and toggle RDn for reading DATA, every BUS transition.

HOST transmits '00' on ADDR[1:0] to indicate that ADDRH is on DAT[7:0], and then '01' on ADDR[1:0] & ADDRl on DAT[7:0], '10' on ADDR[1:0] & BS on DAT[7:0].

After transmitting three bytes, HOST transmits '11' on ADDR[1:0] to read DATA on DAT[7:0].

If there are more than one byte DATA to read, HOST can transmit continuously '11' on ADDR[1:0], and reads a DATA on DAT[7:0].

## 6. Functional Description

W6100 can process internet connectivity by simply manipulating some registers. This section shows how to set relative registers for W6100 initialization, using specific protocols like TCP, UDP, IPRAW and MACRAW, and other functions.

### 6.1 Initialization

This shows the initialization of network information and TX/RX buffer memory.

#### 6.1.1 Network Information Setting

It sets the basic network information for IPv4 or IPv6.

Network Configuration Unlock:

```
{  
    /* Network Unlock before set Network Information */  
    NETLCKR = 0x3A;  
}
```

Source Hardware Address:

```
{  
    /* Source Hardware Address, 11:22:33:AA:BB:CC */  
    SHAR[0:5] = { 0x11, 0x22, 0x33, 0xAA, 0xBB, 0xCC };  
}
```

IPv4 Network Information:

```
{  
    /* Gateway IP Address, 192.168.0.1 */  
    GAR[0:3] = { 0xC0, 0xA8, 0x00, 0x01 };  
  
    /* Subnet MASK Address, 255.255.255.0 */  
    SUBR[0:3] = { 0xFF, 0xFF, 0xFF, 0x00 };  
  
    /* IP Address, 192.168.0.100 */  
    SIPR[0:3] = { 0xC0, 0xA8, 0x00, 0x64 };  
}
```

IPv6 Network Information:

```
{  
    /* Link Local Address, FE80::1322:33FF:FEAA:BBCC */  
}
```

```

LLAR[0:15] = { 0xFE, 0x80, 0x00, 0x01, 0x00, 0x00, 0x00, 0x00,
              0x13, 0x22, 0x33, 0xFF, 0xFE, 0xAA, 0xBB, 0xCC };

/* Global Unicast Address, 2001:0DB8:E001::1222:33FF:FEAA:BBCC */
GUAR[0:15] = { 0x20, 0x01, 0x0D, 0xB8, 0xE0, 0x01, 0x00, 0x00,
              0x13, 0x22, 0x33, 0xFF, 0xFE, 0xAA, 0xBB, 0xCC };

/* IPv6 Subnet Mask Address, FFFF:FFFF:: */
SUB6R[0:15] = { 0xFF, 0xFF, 0xFF, 0xFF, 0xFF, 0xFF, 0xFF, 0xFF,
              0x00, 0x00, 0x00, 0x00, 0x00, 0x00, 0x00, 0x00 };

/* IPv6 Gateway Address, FE80::1322:33FF:FE44:5566 */
GA6R[0:15] = { 0xFE, 0x80, 0x00, 0x00, 0x00, 0x00, 0x00, 0x00,
              0x13, 0x22, 0x33, 0xFF, 0xFE, 0x44, 0x55, 0x66 };
}

```

Network Configuration Lock:

```

{
    /* Network Lock before set Network Information */
    NETLCKR = Any value except 0x3A;
}

```

## 6.1.2 SOCKET TX/RX Buffer Size Setting

Users need to define SOCKET n TX/RX buffer size by setting Sn\_TX\_BSR/Sn\_RX\_BSR before SOCKET is opened.

SOCKET n TX/RX buffer size can be set to 0, 1, 2, 4, 8 or 16KB but the total size of TX or RX buffer should not exceed 16KB each.

```

In case of, assign 2Kbytes RX/TX buffer per SOCKET
{
    // set Base Address of TX/RX buffer for SOCKET n
    TxTotalSize = 0;          // for check the total size of SOCKET n TX Buffer
    RxTotalSize = 0;          // for check the total size of SOCKET n RX Buffer

    for (n=0; n<7; n++) {

```

```

Sn_TX_BSR = 2; // assign 2 Kbytes TX buffer per SOCKET
Sn_RX_BSR = 2; // assign 2 Kbytes RX buffer per SOCKET

TxTotalSize = TxTotalSize + Sn_TX_BSR;
RxTotalSize = RxTotalSize + Sn_RX_BSR;

If( TxTotalSize > 16 or RxTotalSize > 16 ) goto ERROR; // invalid Total Size
} // end for
}

```

## 6.2 TCP

TCP (Transmission Control Protocol) is a bidirectional data transmission protocol based on a 1:1 connection-oriented communication in the transport layer. TCP provides communication between applications which are designated by a port number.

TCP 1:1 communication needs the connection process such as transmitting connection request to peer or receiving connection request from peer. In this connection process, the side transmitting connection request is called 'TCP CLIENT' and the other side receiving connection request is called 'TCP SERVER.' TCP provides reliable, ordered, and error-checked delivery of a stream data between peer systems. 'TCP SERVER' and 'TCP CLIENT' keep the connection and send / receive a data until the TCP connection is terminated.

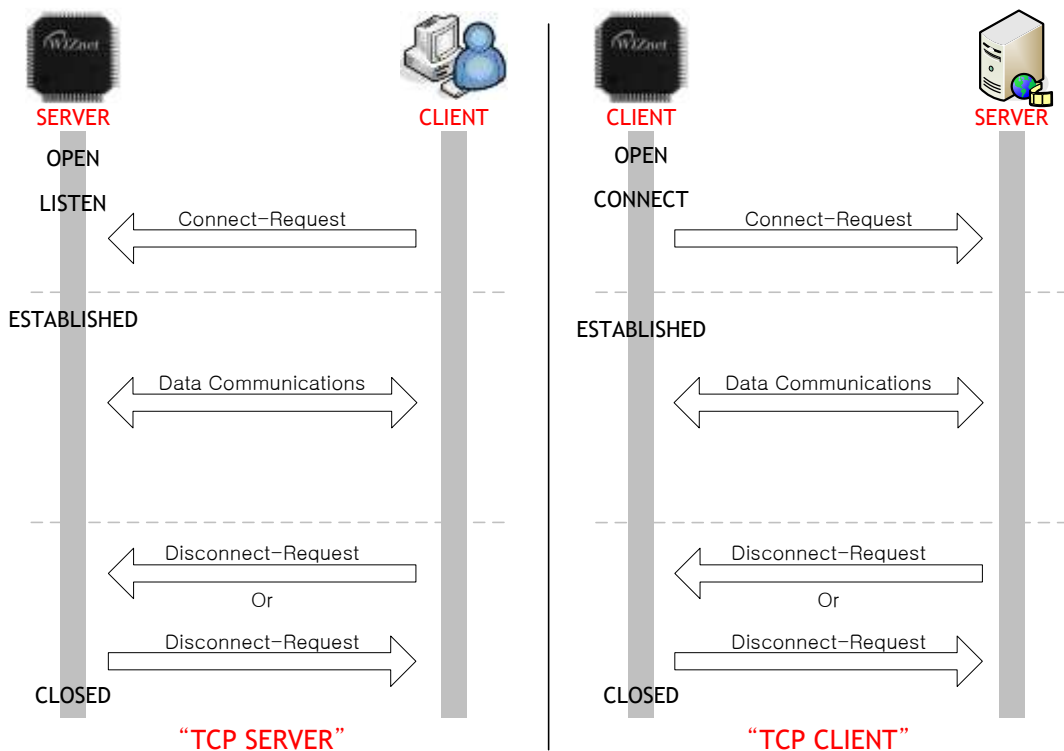

Figure 20 TCP SERVER and TCP CLIENT

## 6.2.1 TCP SERVER

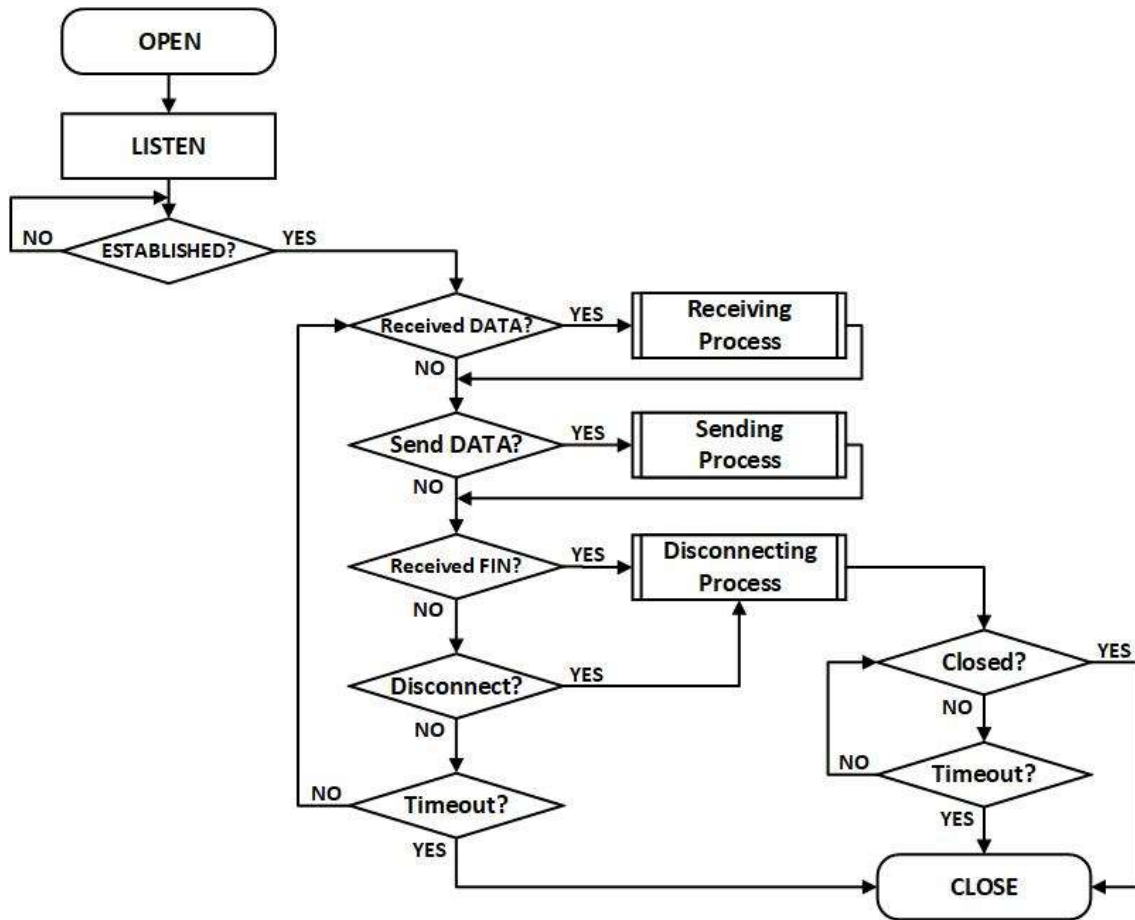

Figure 21 TCP SERVER Operation Flow

- OPEN

Open the SOCKET n as TCP4 or TCP6 mode.

```
TCP Mode : TCP4, TCP6
```

```
{
```

```
START :
```

```
Sn_MR[3:0] = '0001'; /* set TCP4 Mode */
```

```
// Sn_MR[3:0] = '1001'; /* set TCP6 Mode */
```

```
Sn_PORTR[0:1] = {0x13,0x88}; /* set PORT Number, 5000(0x1388) */
```

```
Sn_CR[OPEN] = '1'; /* set OPEN Command */
```

```
while(Sn_CR != 0x00); /* wait until OPEN Command is cleared*/
```

```
/* check SOCKET Status */
```

```
if(Sn_SR != SOCK_INIT) goto START;
```

```
}
```

- LISTEN

SOCKET n is listening as 'TCP SERVER' by Sn\_CR [LISTEN] command. Users can check it by reading Sn\_SR (SOCK\_LISTEN).

```
{  
    Sn_CR = LISTEN; /* set LISTEN Command */  
    while(Sn_CR != 0x00); /* wait until LISTEN Command is cleared*/  
  
    if(Sn_SR != SOCK_LISTEN) goto OPEN; /* check SOCKET Status */  
}
```

- ESTABLISHED?

'TCP SERVER' remains LISTEN status (Sn\_SR=SOCK\_LISTEN) until receiving SYN Packet. If 'TCP SERVER' receives SYN packet from 'TCP CLIENT', it transmits SYN/ACK packet to 'TCP CLIENT' and the connection between 'TCP SERVER' and 'TCP CLIENT' is established if it receives ACK packet.

When the connection is established, Sn\_IR[CON] interrupt occurs and Sn\_SR value is changed to SOCK\_ESTABLISHED. And users can read the destination address from the Sn\_DIPR or Sn\_DIP6R register.

First method :

```
{  
    /* check SOCKET Interrupt */  
    if(Sn_IR[CON] == '1')  
    {  
        Sn_IRCLR[CON] = '1'; /* clear SOCKET Interrupt */  
        goto Received DATA?; /* or goto Send DATA?; */  
    } // end if  
    else if(Sn_IR[TIMEOUT] == '1') goto Timeout?;  
  
    /* check destination address */  
    if(Sn_MR[3:0] == TCP6 Mode)  
        destination_addr[0:15] = Sn_DIP6R;  
    else if(Sn_MR[3:0] == TCP4 Mode)  
        destination_addr[0:3] = Sn_DIPR;  
}
```

Second method :

```
{
```

```

/* checnk SOCKET status */
if (Sn_SR == SOCK_ESTABLISHED)
{
    Sn_IRCLR[CON] = '1'; /* clear SOCKET Interrupt */
    goto Received DATA? /* or goto Send DATA?; */
}
else if(Sn_IR[TIMEOUT] == '1') goto Timeout?;

/* check destination address */
if(Sn_MR[3:0] == TCP6 Mode)
    destination_addr[0:15] = Sn_DIP6R;
else if(Sn_MR[3:0] == TCP4 Mode)
    destination_addr[0:3] = Sn_DIPR;
}

```

- **Receive DATA?**

Users can know whether DATA on SOCKET n is received by reading Sn\_IR[RECV] or Sn\_RX\_RSR.

```

First method :
{
    /* check SOCKET RX buffer Received Size */
    if (Sn_RX_RSR > 0) goto Receiving Process;
}

Second method :
{
    /* check SOCKET RECV Interrupt bit */
    if (Sn_IR[RECV] == '1')
    {
        Sn_IRCLR[RECV] = '1'; /* clear SOCKET Interrupt */
        goto Receiving Process;
    } // end if
}

```

- **Receiving Process**

This is the reading process received data from SOCKET n RX buffer block.

After reading received data, users must increase Sn\_RX\_RD by data read size and make W6100 update the RX buffer by issuing Sn\_CR[RECV] command. If data still remains in SOCKET n RX buffer block after Sn\_CR[RECV] command, then Sn\_IR[RECV] interrupt occurs again to inform user that data remains in the buffer.

```
{  
    /* get Received size */  
    get_size = Sn_RX_RSR;  
  
    /* calculate SOCKET n RX Buffer Size */  
    gSn_RX_MAX = Sn_RX_BSR * 1024;  
  
    /* calculate Read Offset Address */  
    get_start_address = Sn_RX_RD;  
  
    /* copy get_size of get_start_address to destination_address */  
    memcpy(get_start_address, destination_address, get_size);  
  
    /* increase Sn_RX_RD as get_size */  
    Sn_RX_RD += get_size;  
  
    /* set RECV Command */  
    Sn_CR[RECV] = '1';  
    while(Sn_CR != 0x00); /* wait until RECV Command is cleared */  
}
```

#### • Send DATA? / Sending Process

This is sending process of data.

After writing data to SOCKET n TX buffer, users should increase Sn\_TX\_WD by written data size and make W6100 transmit data by setting Sn\_CR[SEND]. User should not make the next data transmission process until Sn\_IR[SENDOK] interrupt occurs. Also, Sn\_IR[TIMEOUT] interrupt can occur during data transmission. Refer to [6.7 Retransmission](#).

The occurrence of Sn\_IR[SENDOK] interrupt depends on SOCKET count, data size and network traffic.

Transmission data size should not exceed SOCKET n TX buffer size. Data larger than MSS will split into multiple MSS units.

```
{  
    /* calculate SOCKET n TX Buffer Size */  
    gSn_TX_MAX = Sn_TX_BSR * 1024;  
  
    /* check the Max Size of DATA(send_size) & Free Size of SOCKET n TX  
    Buffer(Sn_TX_FSR) */
```

```

if( send_size > gSn_TX_MAX ) send_size = gSn_TX_MAX;
while(send_size > Sn_TX_FSR); // wait until SOCKET n TX Buffer is free */
/* If you don't want to wait TX Buffer Free
send_size = Sn_TX_FSR; // write DATA as Size of Free Buffer
*/

/* calculate Write Offset Address */
get_start_address = Sn_TX_WR;

/* copy get_size of get_start_address to destination_address */
memcpy(get_start_address, destination_address, send_size);

/* increase Sn_TX_WR as send_size */
Sn_TX_WR += send_size;

/* set SEND and SEND6 Command in each TCP and TCP6 Mode */
Sn_CR = SEND; /* set SEND command in TCP Mode */
while(Sn_CR != 0x00); /* wait until SEND or SEND6 Command is cleared */

/* wait until SEND or SEND6 Command is completed or Timeout is occurred */
while(Sn_IR[SENDOK] == '0' and Sn_IR[TIMEOUT] = '0');

/* clear SOCKET Interrupt*/
if(Sn_IR[SENDOK] == '1') Sn_IRCLR[SENDOK] = '1';
else
    goto Timeout?;
}

```

- **Received FIN (Passive Close)**

This is the passive close process.

When W6100 receives FIN packet from peer, Sn\_IR[DISCON] interrupt occurs and Sn\_SR value will change to SOCK\_CLOSE\_WAIT.

First Method:

```

{
    If(Sn_SR == SOCK_CLOSE_WAIT) goto Disconnecting Process;
}

```

Second Method:

```

{
    If(Sn_IR[DISCON] == '1') goto Disconnecting Process;
}

```

```
}

```

- **Disconnected (Active Close)**

This is the active close process.

It transmits the FIN packet to peer.

```
{
    Sn_CR[DISCON] = '1';    /* send FIN Packet */

    while(Sn_CR != 0x00);   /* wait until DISCON Command is cleared */
    goto Disconnecting Process;
}
```

- **Disconnecting Process**

In passive close, if SOCKET n receives FIN packet from peer and it doesn't have data to transmit anymore, it transmits FIN packet and closes.

In active close, SOCKET transmits FIN packet to peer and waits for FIN packet from peer. It closes when it receives FIN packet from peer. If there is no response to FIN packet within the whole retransmission time, Sn\_IR[TIMEOUT] interrupt occurs.

```
Passive Close: /* received FIN Packet from Destination */
{
    Sn_CR = DISCON;        /* send FIN Packet */
    while(Sn_CR != 0x00);  /* wait until DISCON Command is cleared */

    /* wait until ACK Packet is received */
    while(Sn_IR[DISCON] == '0' and Sn_IR[TIMEOUT] == '0');
    if (Sn_IR[DISCON] == '1')
    {
        Sn_IRCLR[DISCON] = '1';    /* clear Interrupt */
        goto CLOSED;
    }
    else goto Timeout?;
}
```

```
Active Close : /* sent FIN Packet to Destination */
{
    /* wait until FIN Packet is received */
    while(Sn_IR[DISCON] == '0' and Sn_IR[TIMEOUT] == '0');
    if (Sn_IR[DISCON] == '1')
```

```
{
    Sn_IRCLR[DISCON] = '1'; /* clear Interrupt */
    goto CLOSED;
}
else goto Timeout?;
}
```

- **Timeout?**

If there is no response to SYN/DATA/FIN packet, retransmission process works. When retransmission is failed, Sn\_IR[TIMEOUT] interrupt occurs. Refer to [6.7 Retransmission](#).

```
{
    /* check TIMEOUT Interrupt */
    if(Sn_IR[TIMEOUT] == '1')
    {
        Sn_IRCR[TIMEOUT] = '1'; /* clear Interrupt */
        goto CLOSE;
    }
}
```

- **CLOSE**

SOCKET n turns to CLOSE by disconnecting process, Sn\_IR[TIMEOUT] or Sn\_CR[CLOSE].

```
{
    /* Wait until SOCKET n is closed */
    while(Sn_SR != SOCK_CLOSED);
}
```

## 6.2.2 TCP CLIENT

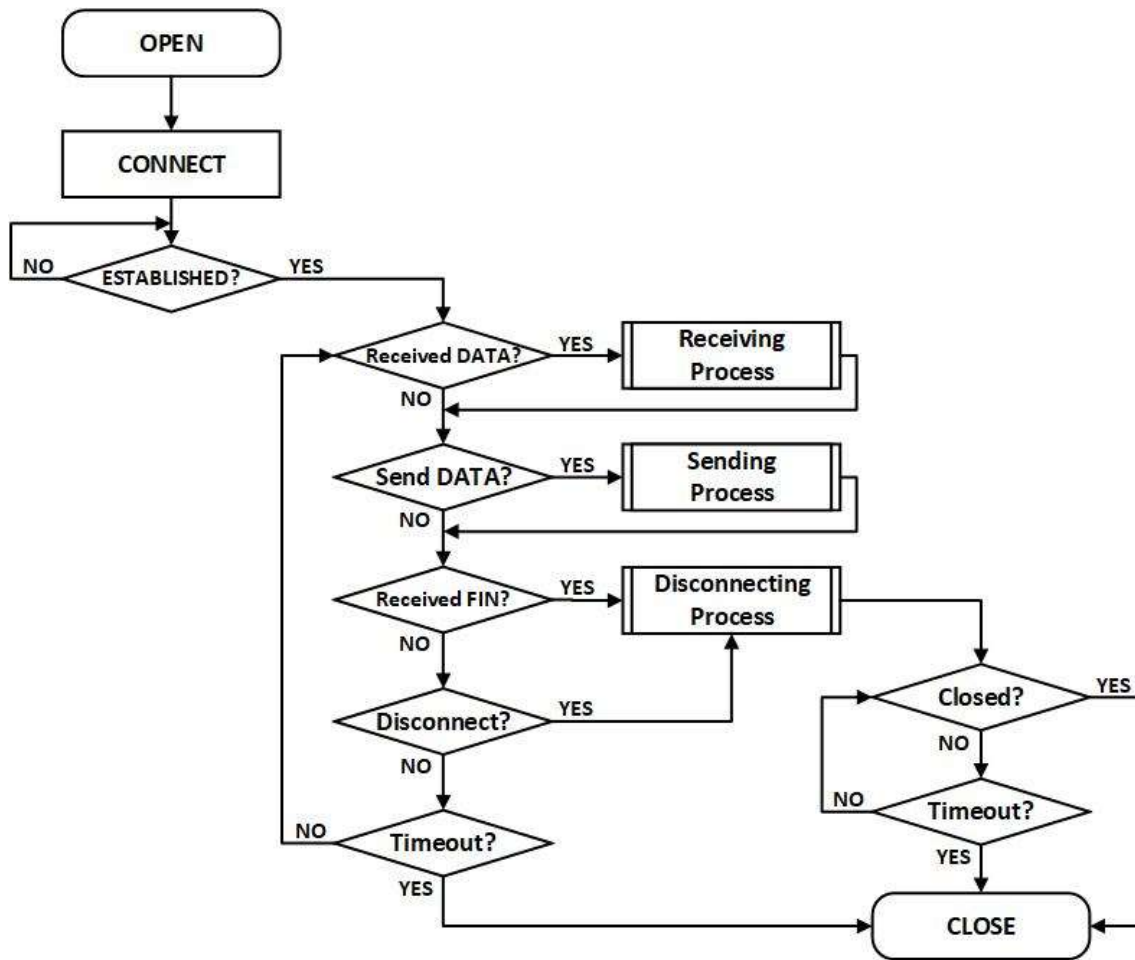

Figure 22 TCP CLIENT Operation Flow

- OPEN

Refer to [6.2.1 TCP S: OPEN](#)

- CONNECT

SOCKET n operates as 'TCP CLIENT' by Sn\_CR[CONNECT].

It transmits SYN packet to 'TCP SERVER' by Sn\_CR[CONNECT] or Sn\_CR[CONNECT6].

```

Sn_MR[3:0] = TCP4:
{
  /* set destination IP address, 192.168.0.11 */
  Sn_DIPR[0:3] = { 0xC0, 0xA8, 0x00, 0x0B };
  /* set destination PORT number, 5000(0x1388) */
  Sn_DPORTR[0:1] = { 0x13, 0x88 };

  Sn_CR = CONNECT; /* set CONNECT command in TCP Mode */
}
  
```

```
while(Sn_CR != 0x00); /* wait until CONNECT or CONNECT6 command is cleared */
goto ESTABLISHED?;
}

Sn_MR[3:0] = TCP6:
{
    /* set destination IP address, FE80::10D:FC:34A:EF90 */
    Sn_DIP6R[0:15] = {0xFE, 0x80, 0x00, 0x00, 0x00, 0x00, 0x00, 0x00,
                    0x01, 0x0D, 0x00, 0xFC, 0x03, 0x4A, 0xEF, 0x90};
    /* set destination PORT number, 5000(0x1388) */
    Sn_PORTR[0:1] = {0x13, 0x88};

    Sn_CR = CONNECT6; /* set CONNECT6 command in TCP6 Mode */
    while(Sn_CR != 0x00); /* wait until CONNECT or CONNECT6 command is cleared */
    goto ESTABLISHED?;
}
```

- **ESTABLISHED?**

After transmitting SYN packet, 'TCP CLIENT' maintains status SOCK\_SYNSENT until receiving SYN/ACK packet from 'TCP SERVER'. When receiving SYN/ACK packet which is transferred from 'TCP SERVER', the connection process between 'TCP SERVER' and 'TCP CLIENT' is completed. If the connection is completed, Sn\_IR[CON] interrupt occurs and Sn\_SR is changed to SOCK\_ESTABLISHED. Users can know the destination address through the Sn\_DIPR or Sn\_DIP6R register.

Refer to [6.2.1 TCP SERVER : ESTABLISHED?](#)

- **Others flow**

Refer to [6.2.1 TCP SERVER : ESTABLISHED?](#)

## 6.2.3 TCP DUAL

SOCKET provides TCP Dual (TCPD) mode based on IP version 4 or 6.

When the SOCKET that is opened in TCPD Mode operates as 'TCP DUAL SERVER' by Sn\_CR [LISTEN], whether it works as TCP4 or TCP6 is determined according to the IP version of connected destination.

When operating as 'TCP DUAL CLIENT', whether it operates as TCP4 or TCP6 is determined by Sn\_CR[CONNECT] or Sn\_CR[CONNECT6].

When the connection is established, the HOST can know whether the SOCKET operates as TCP4 or TCP6 through checking Sn\_ESR[TCPM].

### 6.2.3.1 TCP DUAL SERVER

'TCP DUAL SERVER' operation flow is same to [Figure 21](#).

- OPEN

Open SOCKET n as TCPD mode.

```
TCP Mode : TCP4, TCP6, TCPD
{
START :
    Sn_MR[3:0] = '1101'; /* set TCPD Mode */

    Sn_PORTR[0:1] = {0x13,0x88}; /* set PORT Number, 5000(0x1388) */
    Sn_CR[OPEN] = '1'; /* set OPEN Command */
    while(Sn_CR != 0x00); /* wait until OPEN Command is cleared */

    /* check SOCKET Status */
    if(Sn_SR != SOCK_INIT) goto START;
}
```

- Others flow

Refer to [6.2.1 TCP SERVER](#)

### 6.2.3.2 TCP DUAL CLIENT

'TCP DUAL CLIENT' operation flow is same to [Figure 22](#).

- OPEN

Refer to [6.2.3.1 TCP DUAL SERVER : OPEN](#)

- CONNECT

By Sn\_CR[CONNECT] or Sn\_CR[CONNECT6], SOCKET n sends SYN packet to destination.

```
TCP4 :
{
    /* set destination IP address, 192.168.0.11 */
    Sn_DIPR[0:3] = {0xC0, 0xA8, 0x00, 0x0B};
    /* set destination PORT number, 5000(0x1388) */
    Sn_DPORTR[0:1] = {0x13, 0x88};
}
```

```
Sn_CR = CONNECT; /* set CONNECT command */

while(Sn_CR != 0x00); /* wait until CONNECT or CONNECT6 command is cleared */
goto ESTABLISHED?;
}

TCP6 :
{
    /* set destination IP address, FE80::10D:FC:34A:EF90 */
    Sn_DIP6R[0:15] = {0xFE, 0x80, 0x00, 0x00, 0x00, 0x00, 0x00, 0x00,
                    0x01, 0x0D, 0x00, 0xFC, 0x03, 0x4A, 0xEF, 0x90};
    /* set destination PORT number, 5000(0x1388) */
    Sn_PORTR[0:1] = {0x13, 0x88};

    Sn_CR = CONNECT6; /* set CONNECT6 command */

    while(Sn_CR != 0x00); /* wait until CONNECT or CONNECT6 command is cleared */
    goto ESTABLISHED?;
}
```

- **Others flow**

Refer to. [6.2.1 TCP SERVER](#)

## 6.2.4 Other Functions

### 6.2.4.1 TCP SOCKET Options

Before SOCKET n opens by Sn\_CR[OPEN] command, users need to set SOCKET option with Sn\_MR and Sn\_MR2.

- **No Delayed ACK : Sn\_MR[ND] = '1'**

No Delayed ACK option is for sending ACK packet without any delay when it received DATA from peer.

- **Delayed ACK : Sn\_MR[ND] = '0'**

If No Delayed ACK option is cleared, SOCKET responses ACK packet to data from peer when time in RTR elapsed or when TCP window size becomes smaller than the configured MSS by Sn\_CR[RECV] command.

- **Force PSH Flag : Sn\_MR[FPSH] = '1'**

If Force PSH option is set, SOCKET puts PSH flag in every DATA packet to be transmitted.

- **Auto PSH Flag : Sn\_MR[FPSH] = '0'**  
If Force PSH option is cleared, SOCKET places the PSH flag in the last DATA packet sent by Sn\_CR[SEND].
- **Destination Hardware Address by Sn\_DHAR : Sn\_MR2[DHAM] = '1'**  
If Sn\_MR2[DHAM] is set, ARP/ND-process is skipped and Sn\_DHAR is used as destination hardware address.
- **Destination Hardware Address by ARP : Sn\_MR2[DHAM] = '0'**  
In 'TCP SERVER' mode, destination hardware address is acquired from received SYN packet.  
In 'TCP CLIENT' mode, destination hardware address is acquired from ARP/ND-process.
- **Destination Hardware Address by Sn\_DHAR : Sn\_MR2[FARP] = '1'**  
In 'TCP SERVER' mode, ARP process is performed before responding a SYN / ACK packet to the SYN packet received from the "TCP client". And the address acquired from ARP/ND-process is used as the destination hardware address.  
If Sn\_MR2 [DHAM] is also set, ARP/ND-process is performed but the Sn\_DHAR is used as the destination hardware address.
- **Destination Hardware Address Mode by ARP : Sn\_MR2[FARP] = '0'**  
In 'TCP SERVER' mode, destination hardware address is acquired from received SYN packet.  
In 'TCP CLIENT' mode, destination hardware address is acquired from ARP/ND-process.

#### 6.2.4.2 Keep Alive

Keep Alive (KA) is to retransmit the last 1 byte of the already transmitted DATA packet to check whether the connection is valid. Data size of 1 byte or more must be transmitted before using Keep Alive function. If there is no response to KA packet within the whole retransmission time, Sn\_IR[TIMEOUT] interrupt occurs.

The period of KA packet transmission is set in Sn\_KPALVTR. If Sn\_KPALVTR is set to zero, KA packet is able to be transmitted by Sn\_CR[SEND\_KEEP] command.

## 6.3 UDP

UDP (User Datagram Protocol) is a datagram communication protocol and doesn't guarantee the stability in transport layer above the IP layer. It also uses port numbers to distinguish applications to communicate. UDP can communicate with more than one peer and doesn't require the connection process. On the other hand, UDP may have data loss and receives data from any peers because UDP has no guarantee reliability. UDP Communication is divided to Unicast, Broadcast, and Multicast by data transmission/reception coverage.

Figure 23 shows UDP Operation Flow.

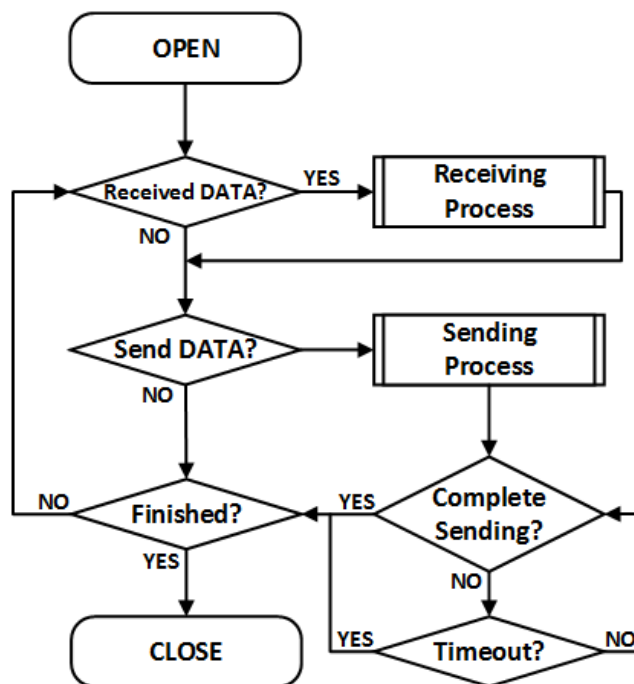

Figure 23 UDP Operation Flow

### 6.3.1 UDP Unicast

UDP Unicast is a communication method where the sender is one and receiver is one. Before data transmission, SOCKET performs the ARP/ND-process. In the ARP/ND-process, Sn\_IR[TIMEOUT] interrupt can occur. Refer to [6.7 Retransmission](#).

If Sn\_MR2[DHAM] is set, ARP/ND-process is skipped and Sn\_DHAR is used as destination hardware address.

UDP Unicast operation flow is same to Figure 23.

- OPEN

Open SOCKET n to UDP4 or UDP6 mode.

```

UDP4, UDP6 Mode :
{
START :
  Sn_MR[3:0] = '0010'; /* set UDP4 Mode */
  // Sn_MR[3:0] = '1010; /* set UDP6 Mode */

  /* set Source PORT Number, 5000(0x1388) */
  Sn_PORTR[0:1] = {0x13, 0x88};

  Sn_CR[OPEN] = '1'; /* set OPEN Command */
  while(Sn_CR != 0x00); /* wait until OPEN Command is cleared */

  /* check SOCKET for UDP6 Mode */
  if(Sn_SR != SOCK_UDP) goto START;
}

```

• Received DATA?

Refer to [6.2.1 TCP SERVER: Received DATA?](#)

• Receiving Process

UDP mode SOCKET can receive DATA packets from more than one peer. The received DATA packet is stored in SOCKET n RX buffer block with “PACKET INFO” as shown in [Figure 24](#).

HOST must read DATA from SOCKET n RX buffer in the format of [Figure 24](#). If the received DATA is fragmented or bigger than SOCKET n RX buffer free size, it is discarded.

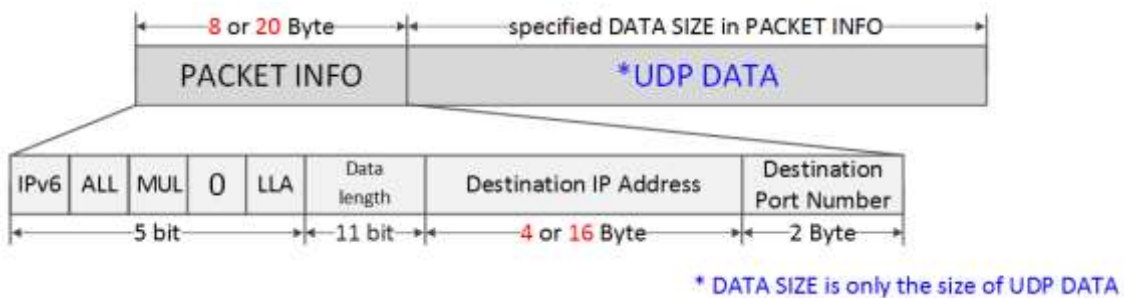

Figure 24 Received DATA in UDP Mode SOCKET RX Buffer Block

Table 4 Parameter Description in PACKET INFO

PACKET INFO	Description
IPv6	0 : UDP/IPv4 Packet is received 1 : UDP/IPv6 Packet is received
BRD/ALL	0 : Others

	1 : Broadcast/All-node-Multicast Packet is received
MUL	0 : Others 1 : Multicast Packet is received
0	Always '0'
LLA	0 : GUA 1 : LLA
DATA Length	*UDP DATA Length
Destination IP Address	If UDP4 packet is received, save Destination IPv4 Address (4 Byte) If UDP6 packet is received, save Destination IPv6 Address (16 Byte)
Destination Port Number	Destination Port Number

UDP4 Mode :

```
{
    /* receive PACKINFO */
    goto 6.2.1 TCP SERVER: Receiving Process with get_size = 8 bytes;

    /* extract Destination IP, Port, Size in PACKET INFO */
    data_info = destination_address[0] & "11111000";
    data_size = (destination_address[0] & "00000111" << 8) + destination_address[1];
    if( data_info & '10000000' == 0 ) /* Is Destination IPv4 Address? */
    {
        dest_ip[0:3] = destination_address[2:5];
        dest_port = (destination_address[6] << 8) + destination_address[7];
    }
    /* read UDP DATA */
    goto 6.2.1 TCP SERVER: Receiving Process with get_size = data_size;
}
```

UDP6 Mode :

```
{
    /* receive PACKINFO */
    goto 6.2.1 TCP SERVER: Receiving Process with get_size = 20 bytes;

    /* extract Destination IP, Port, Size in PACKET INFO */
    data_info = destination_address[0] & "11111000";
    data_size = (destination_address[0] & "00000111" << 8) + (destination_address[1];
    if( data_info & '10000000' != 0) /* Is Destination IPv6 Address? */
```

```

{
    dest_ip[0:15] = destination_address[2:17];
    dest_port = (destination_address[18] << 8) + destination_address[19];
}
/* read UDP DATA */
goto 6.2.1 TCP SERVER: Receiving Process with get_size = data_size;
}

```

- Send DATA? / Sending Process

Refer to [6.2.1 TCP SERVER: Send DATA? / Sending Process](#)

```

UDP4 Mode
{
    /* set destination IP address, 192.168.0.11 */
    Sn_DIPR[0:3] = {0xC0, 0xA8, 0x00, 0x0B};
    /* set destination PORT number, 5000(0x1388) */
    Sn_DPORTR[0:1] = {0x13, 0x88};

    goto 6.2.1 TCP SERVER: Sending Process with Sn_CR[SEND];
}

UDP6 Mode
{
    /* set destination IP address, FE80::10D:FC:34A:EF90 */
    Sn_DIP6R[0:15] = {0xFE, 0x80, 0x00, 0x00, 0x00, 0x00, 0x00, 0x00,
                    0x01, 0x0D, 0x00, 0xFC, 0x03, 0x4A, 0xEF, 0x90};
    /* set destination PORT number, 5000(0x1388) */
    Sn_DPORTR[0:1] = {0x13, 0x88};

    goto 6.2.1 TCP SERVER: Sending Process with Sn_CR[SEND6];
}

```

- Complete Sending? / Timeout?

When HOST sends data to a destination at the beginning or a different destination, ARP process is performed prior to transmitting DATA packet. In the ARP Process, if there is no response to ARP request from peer within the whole retransmission time, Sn\_IR[TIMEOUT] interrupt occurs. Unlike TCP, UDP SOCKET does not close by Sn\_IR[TIMEOUT] because it supports 1:N communication.

Refer to [6.7 Retransmission](#).

```
{
    /* check TIMEOUT Interrupt */
    if(Sn_IR[TIMEOUT] == '1')
    {
        Sn_IR[TIMEOUT] = '1'; /* clear TIMEOUT Interrupt */
        goto Finished?;
    }
}
```

- **Finished? / CLOSE**

Closed by Sn\_CR[CLOSED].

```
{
    Sn_CR = CLOSE; /* set CLOSE Command */
    while(Sn_CR != 0x00); /* wait until CLOSE Command is cleared*/

    /* wait until SOCKET n is closed */
    while(Sn_SR == SOCK_CLOSED);
}
```

### 6.3.2 UDP Broadcast

UDP Broadcast is a communication method where the sender transmits data to all on the same network.

There are two types of broadcasting; all node broadcasting for all nodes in the network and subnet broadcasting for the nodes having the same subnet in the network.

In UDP6 mode, using FF02::01 address, which is an all-node multicast address, makes the same action as all-node broadcasting of UDP4.

- **OPEN**

Refer to [6.3.1 UDP Unicast: OPEN](#)

- **Received DATA?**

Refer to [6.2.1 TCP SERVER: Received DATA?](#)

- **Receiving Process**

Refer to [6.3.1 UDP Unicast: Receiving Process](#)

- Send DATA? / Sending Process

Set destination address for UDP4 broadcasting and UDP6 all-node multicasting

UDP4 All Node Broadcasting :

```
{  
    /* set broadcast address, 255.255.255.255 */  
    Sn_DIPR[0:3] = {0xFF, 0xFF, 0xFF, 0xFF};  
    /* set Destination PORT Number, 5000(0x1388) */  
    Sn_DPORTR[0:1] = {0x13,0x88};  
  
    goto 6.2.1 TCP SERVER: Sending Process with Sn_CR[SEND];  
}
```

UDP4 Subnet Broadcasting : Assume SIPR = "192.168.0.10" & SUBR = "255.255.255.0"

```
{  
    /* set Broadcast Address, 192.168.0.255 */  
    Sn_DIPR[0:3] = {0xC0, 0xA8, 0x00, 0xFF};  
    /* set Destination PORT Number, 5000(0x1388) */  
    Sn_DPORTR[0:1] = {0x13,0x88};  
  
    goto 6.2.1 TCP SERVER: Sending Process with Sn_CR[SEND];  
}
```

UDP6 All-Node Multicasting :

```
{  
    /* set destination IP address, FF02::01 */  
    Sn_DIP6R[0:15] = {0xFF, 0x02, 0x00, 0x00, 0x00, 0x00, 0x00, 0x00,  
                    0x00, 0x00, 0x00, 0x00, 0x00, 0x00, 0x00, 0x01};  
    /* set Destination PORT Number, 5000(0x1388) */  
    Sn_DPORTR[0:1] = {0x13,0x88};  
  
    goto 6.2.1 TCP SERVER: Sending Process with Sn_CR[SEND];  
}
```

- Complete sending? / Timeout?

Refer to [6.3.1 UDP Unicast: Complete Sending? / Timeout?](#)

- Finished? / CLOSE

Refer to [6.3.1 UDP Unicast: Finished? / CLOSE](#)

### 6.3.3 UDP Multicast

UDP multicast is a communication method where the sender is one and receiver is a group.

In IPv4 mode, the multicast-group address range is 224.0.0.0 ~ 239.255.255.255 (Ref [IANA\\_Multicast Address](#)) and the corresponding hardware address address is 01:00:5E:00:00:00 ~ 01:00:5E:FF:FF:FF. When setting the multicast hardware address, its least significant 23 bits should be same to the multicast-group address. (Ref [rfc1112](#))

In IPv6 mode, set the multicast-group address like [Figure 25](#).

The UDP multicast operation flow is same to [Figure 23](#).

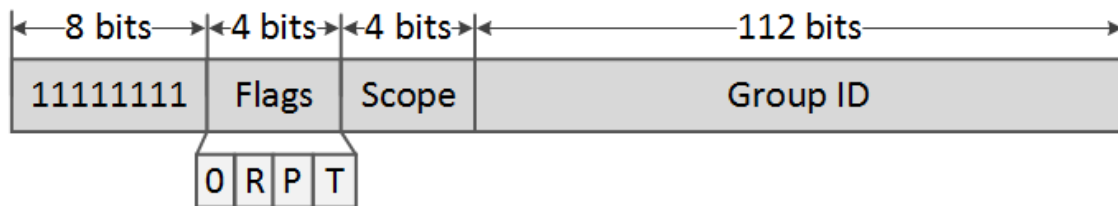

Figure 25 IPv6 Multicast-Group Address Format

Table 5 Parameters of Flags in IPv6 Multicast Address

Flags	Description
0	Always '0'
R	1 : Embedded RP 0 : No embedded RP * If R = '1', P must be '1'
P	1 : Based on Unicast Network Prefix 0 : Not based on Unicast Network Prefix * If P = '1', T must be '1'
T	1 : Temporary address(Local assigned) 0 : Permanent address(IANA assigned)

Table 6 Definition of Scope in IPv6 Multicast Address

Scope	Description
1	Node
2	Link
3	Subnet
4	Admin
5	Site
8	Organization
E	Global

- OPEN

Before Sn\_CR [OPEN] command, multicast-group information and Sn\_MR[MULTI] must be set.

In UDP4 multicast mode, IGMP (Internet Group Management Protocol) JOIN message is transmitted by Sn\_CR[OPEN] command. IGMP version is set as version 1 or version 2 by Sn\_MR[MS].

In UDP6 multicast mode, join to a multicast-group using MLDv1.

UDP4 Multicast Mode :

```
{
START :
    /* set Multicast-Group hardware address, 01:00:5E:00:00:64 */
    Sn_DHAR[0:5] = {0x01, 0x00, 0x5E, 0x00, 0x00, 0x64};
    /* set Multicast-Group IP Address, 224.0.0.100 */
    Sn_DIPR[0:3] = {0xE0, 0x00, 0x00, 0x64}
    /* set Multicast-Group PORT Number, 3000(0x0BB8) */
    Sn_DPORTR[0:1] = {0x0B, 0xB8};

    Sn_MR[MULTI] = '1'; /* set UDP Multicast */

    /* set IGMP Version
    Sn_MR[MC] = '1' : IGMPv1 ,
    Sn_MR[MC] = '0' : IGMPv2 */
    Sn_MR[MC] = '1';

    goto 6.3.1 UDP Unicast : OPEN(UDP Mode)
}
```

UDP6 Multicast Mode :

```
{
START :
    /* set Multicast-Group hardware Address, 33:33:00:AB:34:56 */
    Sn_DHAR[0:5] = {0x33, 0x33, 0x00, 0xAB, 0xCD, 0xEF};
    /* set Multicast-Group IP Address, FF02::100:00AB:CDEF */
    Sn_DIP6R[0:15] = {0xFF, 0x02, 0x00, 0x00, 0x00, 0x00, 0x00, 0x00,
                    0x00, 0x00, 0x00, 0x01, 0x00, 0xAB, 0xCD, 0xEF};
    /* set Multicast-Group PORT Number, 3000(0x0BB8) */
    Sn_DPORTR[0:1] = {0x0B, 0xB8};

    Sn_MR[MULTI] = '1'; /* set UDP Multicast */
}
```

```
goto 6.3.1 UDP Unicast : OPEN(UDP6 Mode)
}
```

- Received DATA?

Refer to [6.2.1 TCP SERVER: Received DATA?](#)

- Receiving Process

Refer to [6.3.1 UDP Unicast: Receiving Process](#)

- Send DATA? / Sending Process

Refer to [6.3.1 UDP Unicast: Sending Process](#)

- Complete sending? / Timeout?

Refer to [6.3.1 UDP Unicast: Complete Sending? / Timeout?](#)

- Finished? / CLOSE

Refer to [6.3.1 UDP Unicast: Finished? / CLOSE](#)

## 6.3.4 UDP DUAL

SOCKET provides UDP dual (UDPD) mode based on W6100 Dual Stack (IPv4 / IPv6). SOCKET opened in UDPD mode can transmit/receive all UDP4/UDP6 packets.

UDP4 data and UDP6 data can be transmitted by Sn\_CR[SEND] and Sn\_CR[SEND6] respectively, and received UDP4 data and UDP6 data can be distinguished by 'PACKET INFO' of the received packet.

The UDPD operation flow is same as [Figure 23](#).

- OPEN

Open the SOCKET n to UDP Dual mode.

```
UDP6 Mode
{
START :
    Sn_MR[3:0] = '1110'; /* set UDPD Mode */

    /* set Source PORT Number, 5000(0x1388) */
    Sn_PORTR[0:1] = {0x13, 0x88};

    Sn_CR[OPEN] = '1'; /* set OPEN Command */
    while(Sn_CR != 0x00); /* wait until OPEN Command is cleared */
```

```

/* check SOCKET for UDPD Mode */
if(Sn_SR != SOCK_UDP) goto START;
}

```

- Received DATA?

Refer to [6.2.1 TCP SERVER: Received DATA?](#)

- Receiving Process

UDP dual mode SOCKET can receive UDP4 / UDP6 packets from one or more destinations, and the received data packets are stored in SOCKET n RX buffer with 'PACKET INFO'. HOST can know the IP version, transmission method, and destination information of received data packet from the 'PACKET INFO'.

HOST must read data from SOCKET n RX buffer in the format of [Figure 24](#). If the received data is fragmented or bigger than SOCKET n RX buffer free size, it is discarded.

Refer to [Figure 24 and Table 4](#)

```

{
/* extract upper 2 bytes in PACKINFO */
goto 6.2.1 TCP SERVER: Receiving Process with get_size = 2 bytes;

data_size = (destination_address[0] & "00000111" << 8) + destination_address[1];

/*
check UDP4 or UDP6 DATA Packet, extract Destination IP, Port, Size in PACKE INFO
*/
if(destination_address[0] & "10000000" == 0) /* UDP4 DATA Packet */
{
goto 6.2.1 TCP SERVER: Receiving Process with get_size = 6 bytes;
dest_ip[0:3] = destination_address[0:3];
dest_port = (destination_address[4] << 8) + destination_address[5];
}
else /* UDP6 DATA Packet */
{
goto 6.2.1 TCP SERVER: Receiving Process with get_size = 18 bytes;
dest_ip[0:15] = destination_address[0:15];
dest_port = (destination_address[16] << 8) + destination_address[17];
}
/* read UDP DATA */
}

```

```
goto 6.2.1 TCP SERVER : Receiving Process with get_size = data_size;  
}
```

- **Send DATA? / Sending Process**

Refer to [6.3.1 UDP Unicast : Send Data? / Sending Process](#)

- **Complete sending? / Timeout?**

Refer to [6.3.1 UDP Unicast: Complete Sending? / Timeout?](#)

- **Finished? / CLOSE**

Refer to [6.3.1 UDP Unicast: Finished? / CLOSE](#)

## 6.3.5 Other Functions

### 6.3.5.1 UDP Mode SOCKET Options

Before Sn\_CR[OPEN] command, SOCKET option can be set by Sn\_MR and Sn\_MR2.

- **Destination Hardware Address by Sn\_DHAR : Sn\_MR2[DHAM]= '1'**

ARP/ND-process is skipped and Sn\_DHAR is used as the destination hardware address.

- **Destination Hardware Address by ARP : Sn\_MR2[DHAM]= '0'**

The destination hardware address of UDP data to be transmitted is used as the acquired address from ARP/ND-process.

- **Force ARP : Sn\_MR2[FARP]= '1'**

ARP/ND-process is performed whenever UDP DATA packet is transmitted by Sn\_CR[SEND] or Sn\_CR[SEND4].

If Sn\_MR2 [DHAM] is also set, ARP/ND-process is performed but the Sn\_DHAR is used as the destination hardware address.

- **Auto ARP : Sn\_MR2[FARP]= '0'**

ARP/ND-process is performed when the first UDP data packet is transmitted or when the destination is changed.

### 6.3.5.2 UDP Block

In UDP Mode, Unicast and Broadcast packets can be received. But Broadcast packets are blocked if Sn\_MR[BRDB] is set to '1'.

In UDP Multicast mode, Unicast, Broadcast and Multicast packets can be received. But if Sn\_MR[UNIB] or Sn\_MR[BRDB] are set to '1', Unicast or Broadcast packets are blocked respectively.

These block bits must be set before Sn\_CR[OPEN] command.

Sn_MR[MULTI]	Sn_MR[BRDB]	Sn_MR[UNIB]	Unicast	Multicast	Broadcast
0	0	Don't Care	0	X	0
0	1	Don't Care	0	X	X
1	0	0	0	0	0
1	0	1	X	0	0
1	1	0	0	0	X
1	1	1	X	0	X

In UDP6 or UDPD mode, Solicited Multicast packet is blocked when Sn\_MR[SMB] is set to '1'.

### 6.3.5.3 Port Unreachable Block

W6100 automatically transmits **destination port unreachable packet** to the sender when a sender transmits a UDP packet to a port that didn't open on W6100. But it could be a target for port scan attack.

In UDP4 or UDP6, port unreachable packet is blocked by setting NET4MR[UNRB] = '1' or NET6MR[UNRB] = '1'.

## 6.4 IPRAW

IPRAW supports protocol communication shown in Table 7 among various upper protocols (Refer to [IANA Protocol Numbers](#)) defined in the internet protocol layer.

When SOCKET n is opened as IPRAW4 or IPRAW6, Sn\_PNR configures the value of field or IPv6 extension header. SOCKET n cannot communicate by using a protocol different from the protocol set in Sn\_PNR.

Table 7 Internet Protocol supported in IPRAW Mode

Protocol	Number	Semantic	Support
HOPOPT	0	IPv6 Hop-by-Hop Option	0
ICMP	1	Internet Control Message Protocol	0
IGMP	2	Internet Group Management	0
IPv4	4	IPv4 encapsulation	0
TCP	6	Transmission Control	X
UDP	17	User Datagram	X
IPv6	41	IPv6 encapsulation	0
ICMP6	58	ICMP for IPv6	0
others	-	Other Protocols	0

In the case of Sn\_PNR = ICMP in IPRAW4 mode, Auto PING reply to PING-request from a sender is not supported. PING-request packet is stored in SOCKET n RX buffer block for IPRAW. It should be processed by users.

In the case of Sn\_PNR = ICMP6 in IPRAW6 mode, Auto reply packet transmission to echo Request, NA (Neighbor Advertisement), NS (Router Advertisement) and RA (Router Advertisement) can be blocked via ICMP6BLKR setting. Blocked packets are not stored in SOCKET n RX Buffer.

Figure 26 shows the SOCKET n operation flow in IPRAW4/IPRAW6 mode.

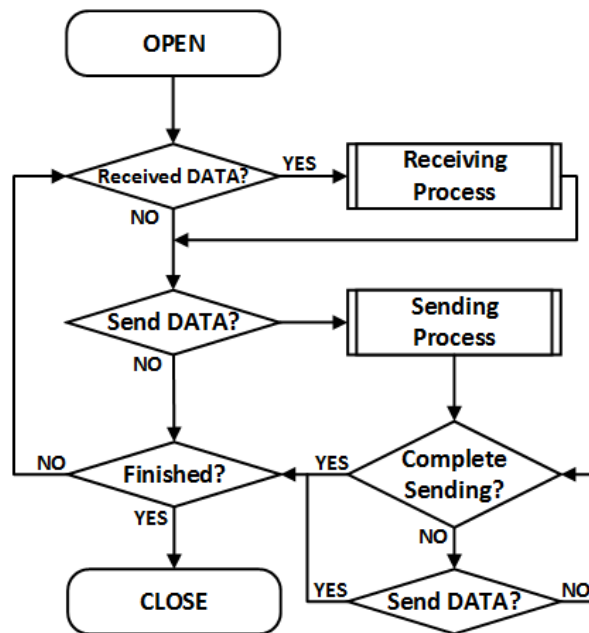

Figure 26 IPRAW Operation Flow

- OPEN

Open SOCKET n as IPRAW4 or IPRAW6 mode.

IPRAW4 Mode :

{

START :

```
Sn_PNR = protocol_num; /* set Protocol Number */
```

```
Sn_MR[3:0] = '0011'; /* set IPRAW4 Mode */
```

```
Sn_CR[OPEN] = '1'; /* set OPEN Command */
```

```
while(Sn_CR != 0x00); /* wait until OPEN Command is cleared */
```

```
/* check SOCKET for IPRAW6 Mode */
```

```

if(Sn_SR != SOCK_IPRAW6) goto START;
}
IPRAW6 Mode :
{
START :
    Sn_PNR = protocol_num;    /* set Protocol Number(Next Header) */

    Sn_MR[3:0] = '1001';    /* set IPRAW6 Mode */

    Sn_CR[OPEN] = '1';    /* set OPEN Command */
    while(Sn_CR != 0x00); /* wait until OPEN Command is cleared */

    /* check SOCKET for IPRAW Mode */
    if(Sn_SR != SOCK_IPRAW) goto START;
}

```

• Received DATA?

Refer to [6.2.1 TCP SERVER: Received DATA?](#)

• Receiving Process

IPRAW4/IPRAW6 mode receives IP DATA packets from one or more sender. To distinguish each sender, DATA packet is stored in the SOCKET n RX buffer block with preceding 'PACKET INFO' as shown in [Figure 27](#) or [Figure 28](#). 'PACKET INFO' has different formats according to IPRAW4/IPRAW6 mode as shown in [Table 8](#) and [Table 9](#).

If the received DATA is larger than SOCKET n RX buffer free size, it is discarded. Thus, the HOST must be read in unit of [Figure 27](#) or [Figure 28](#).

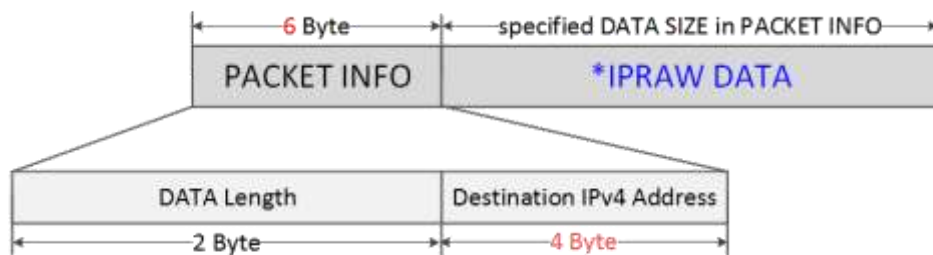

\* IPRAW DATA is only the size of DATA in Received Packet

Figure 27 Received DATA in IPRAW4 Mode SOCKET RX Buffer Block

Table 8 parameters of 'PACKET INFO' in IPRAW4 Mode

PACKET INFO	Description
DATA Length	The length of *IPRAW DATA
Destination IPv4 Address	Destination IPv4 Address (4 Byte)

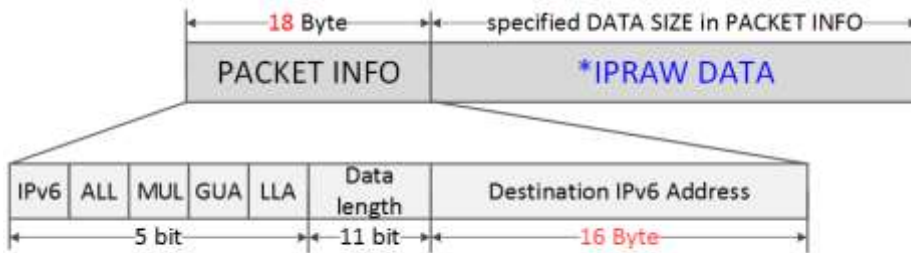

\* IPRAW DATA is only the size of DATA in Received Packet

Figure 28 Received DATA in IPRAW6 Mode SOCKET RX Buffer Block

Table 9 parameters of 'PACKET INFO' in IPRAW6 Mode

PACKET INFO	Description
IPv6	If IPv6 Packet is received, set to '1'
ALL	If All Node Packet is received, set to '1'
MUL	If Multicast Packet is received, set to '1'
GUA	If Destination Address is GUA, set to '1'
LLA	If Destination Address is LLA, set to '1'
DATA Length	The length of *IPRAW DATA
Destination IPv6 Address	Destination IPv6 Address (16 Byte)

IPRAW4 Mode :

```
{
/* receive PACKINFO */
goto 6.2.1 TCP S: Receiving Process with get_size = 6;

/* extract Destination DATA Size, IP Address in PACKET INFO*/
data_size = (destination_address[0] << 8) + destination_address[1];
dest_ip[0:3] = destination_address[2:5];

/* read UDP DATA */
goto 6.2.1 TCP SERVER : Receiving Process with get_size = data_size;
}
```

IPRAW6 Mode :

```
{
/* receive PACKINFO */
goto 6.2.1 TCP SERVER: Receiving Process with get_size = 18;

/* extract Destination Information, DATA Size, IP Address in PACKET INFO */
data_Info = destination_address[0] & "11111000";
data_size = (destination_address[0] & "00000111" << 8) + (destination_address[1];
```

```

dest_ip[0:15] = destination_address[2:17];

/* read UDP DATA */
goto 6.2.1 TCP SERVER: Receiving Process with get_size = data_size;
}

```

- **Sending DATA? / Sending Process**

Data to send must not exceed SOCKET n TX buffer free size. If data size is larger than MSS, HOST must split the larger data into multiple MSS units.

MSS of IPRAW6 mode cannot be larger than 1460, MSS of IPRAW mode cannot be larger than 1480.

```

IPRAW4 Mode :
{
/* set Destination IP Address, 192.168.0.11 */
Sn_DIPR[0:3] = {0xC0, 0xA8, 0x00, 0x0B};

goto 6.2.1 TCP SERVER: Sending Process;
}

```

```

IPRAW6 Mode :
{
/* set destination IP address, FE80::10D:FC:34A:EF90 */
Sn_DIP6R[0:15] = {0xFE, 0x80, 0x00, 0x00, 0x00, 0x00, 0x00, 0x00,
0x01, 0x0D, 0x00, 0xFC, 0x03, 0x4A, 0xEF, 0x90};

goto 6.2.1 TCP SERVER: Sending Process;
}

```

- **Complete sending? / Timeout?**

ARP/ND-process is performed before first DATA packet is sent to by Sn\_CR[SEND] or Sn\_CR[SEND6] or before DATA packet is sent to different destination from the previous destination.

In ARP/ND-process, Sn\_IR[TIMEOUT] may occur and the corresponding DATA packet is discarded. Since IPRAW4 or IPRAW6 supports 1:N communication like as UDP, SOCKET n doesn't close even if Sn\_IR[TIMEOUT] occurs (Refer to [0](#) Retransmission).

```

{
/* check TIMEOUT Interrupt */

```

```
if(Sn_IR[TIMEOUT] == '1')
{
    Sn_IR[TIMEOUT] = '1';    /* clear TIMEOUT Interrupt */
    goto Finished?;
}
}
```

- **Finished? / CLOSE**

In case that there is no more data to send, close SOCKET n by Sn\_CR[CLOSE].

```
{
    Sn_CR = CLOSE;    /* set CLOSE Command */
    while(Sn_CR != 0x00);    /* wait until CLOSE Command is cleared*/

    /* wait until SOCKET n is closed */
    while(Sn_SR == SOCK_CLOSED);
}
```

## 6.4.1 Other Functions

### 6.4.1.1 IPRAW Mode SOCKET Options

In the process of opening SOCKET n as IPRAW4/IPRAW6 mode, SOCKET option is set via Sn\_MR and Sn\_MR2.

- **Destination Hardware Address by Sn\_DHAR : Sn\_MR2[DHAM]= '1'**  
ARP/ND-process is skipped and Sn\_DHAR is used as the destination hardware address.
- **Destination Hardware Address by ARP : Sn\_MR2[DHAM]= '0'**  
The destination hardware address of IPRAW data to be transmitted is used as the acquired address from ARP/ND-process.
- **Force ARP : Sn\_MR2[FARP]= '1'**  
ARP/ND-process is performed whenever IPRAW4 or IPRAW6 DATA is transmitted by Sn\_CR[SEND] or Sn\_CR[SEND6].
- **Auto ARP : Sn\_MR2[FARP]= '0'**  
ARP/ND-process is performed when the first IPRAW data packet is transmitted or when the destination is changed.

## 6.5 MACRAW

MACRAW mode supports data communication using Ethernet MAC protocol itself and it is only available with SOCKET 0.

In case of Sn\_MR[MF] = '0', MACRAW SOCKET 0 receives all Ethernet packets.

In case of Sn\_MR[MF] = '1', MACRAW SOCKET 0 can receive only a packet that has the destination hardware address is Broadcast, Multicast or Source Hardware Address (SHAR).

Figure 29 shows MACRAW Mode SOCKET0 Operation Flow.

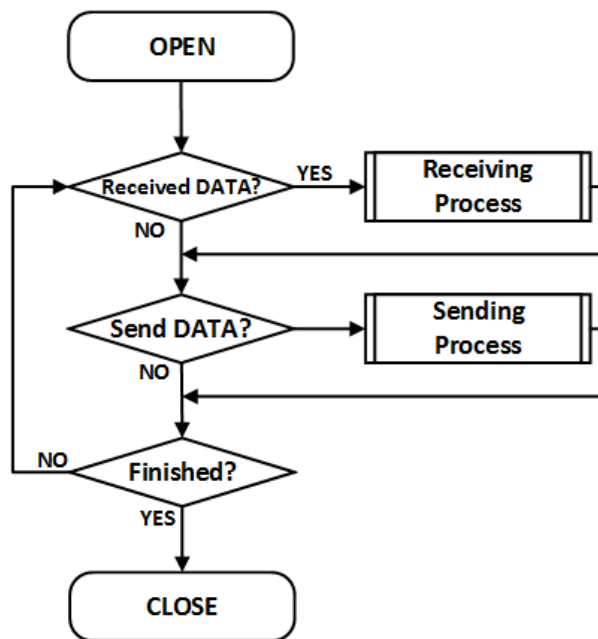

Figure 29 MACRAW Operation Flow

- OPEN

Open SOCKET 0 as MACRAW Mode.

```

{
START :
  SO_MR[3:0] = '0111'; /* set MACRAW Mode */

  /* MACRAW SOCKET Options */
  /* SO_MR[MF] = '1';      // enable MAC Filter
  SO_MR[UNIB] = '1';      // Broadcast Packet Block
  SO_MR[MMB] = '1';       // Multicast Packet Block
  SO_MR[MMB6] = '1';     // IPv6 Packet Block */

  SO_CR = OPEN; /* set OPEN Command */

```

```

while(Sn_CR != 0x00); /* wait until OPEN Command is cleared*/

/* check SOCKET 0 is MACRAW Mode */
if(SO_SR != SOCK_MACRAW) SO_CR = CLOSE; goto START;
}

```

- Received DATA?

Refer to [6.2.1 TCP SERVER: Received DATA?](#)

- Receiving Process

MACRAW mode SOCKET 0 receives data packet from more than one destination. MACRAW Mode SOCKET 0 stores data with preceding 'PACKET INFO' in the SOCKET 0 RX buffer block as shown in Figure 30.

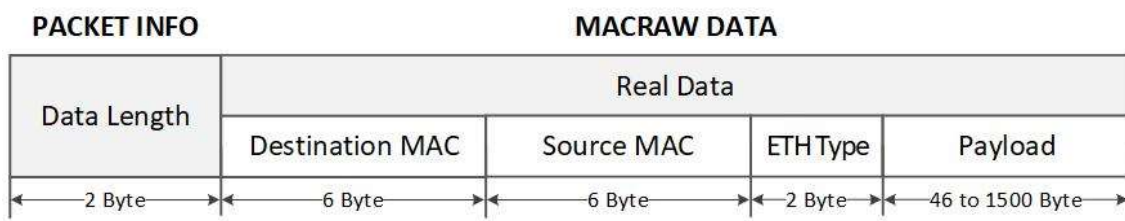

Figure 30 Received DATA Format in MACRAW

```

{
/* receive PACKINFO */
goto 6.2.1 TCP SSERVER: Receiving Process with get_size = 2;

/* extract Size in PACKET INFO*/
data_size = (destination_address[0] << 8) + destination_address[1];

/* read MACRAW DATA */
goto 6.2.1 TCP SSERVER: Receiving Process with get_size = data_size;
}

```

- Sending DATA? / Sending Process

Data to send must not exceed SOCKET 0 TX buffer size. If data is larger than MSS, it must be divided by MSS(1512).

Data smaller than 60 bytes becomes 60 bytes with zero padding.

Refer to [6.2.1 TCP SERVER: Send DATA? / Sending Process](#)

- Finished? / CLOSE

Refer to [6.3.1 UDP Unicast: Finished? / CLOSE](#)

## 6.6 SOCKET-less Command (SLCR)

SOCKET-less command (SLCR) transmits specific packets such as ARP request, PING request, NS, and RS without using the SOCKET resource. The response to the request packet can be checked thorough SLIR. SLIR[TOUT] is set when there is no response until retransmission time expires. Refer to [6.7 Retransmission](#).

Multiple SLCR commands cannot be executed at the same time. After a bit of SLIR is set, the next command can be performed.

[Figure 31](#) shows the flow of SOCKET-less commands.

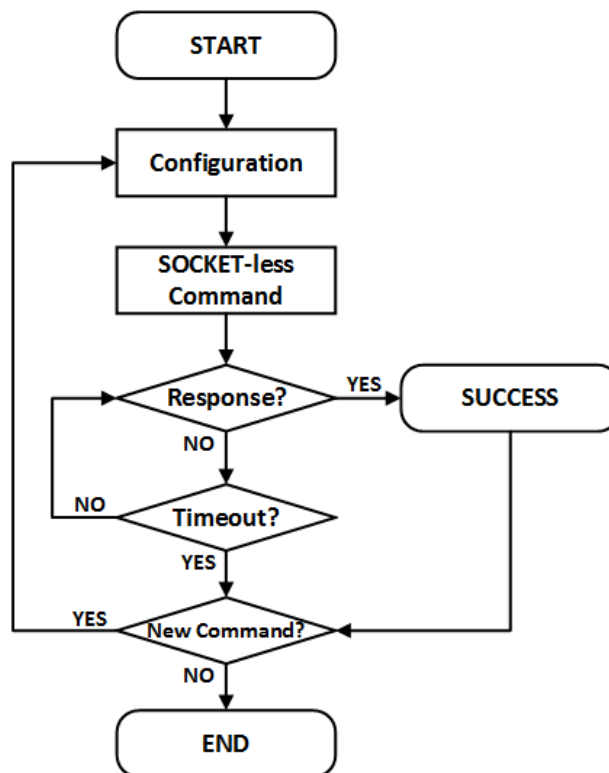

Figure 31 SOCKET-less Command Operation Flow

### 6.6.1 ARP

SLCR[ARP] transmits ARP request packet to the destination specified by SLDIPR. If ARP reply is received from a device, SLIR[ARP] is set and destination hardware address is saved in SLDHAR. If there is no response until the retransmission time expires, SLIR[TOUT] is set.

Refer to [6.7 Retransmission](#).

- **Configuration**

Configure retransmission time, ARP &TOUT interrupt mask, and destination IP address,

```
{
START :
    /* set SOCKET-less Retransmission Time, 100ms(0x03E8) (Unit 100us) */
    // SLRTR[0:1] = {0x03, 0xE8};

    /* set SOCKET-less Retransmission Counter, 5 */
    // SLRCR = 0x05;

    /* set Interrupt Mask Bit */
    //SLIMR[ARP] = '1'; /* ARP Interrupt Mask Bit */
    //SLIMR[TOUT] = '1'; /* TIMEOUT Interrupt Mask Bit */

    /* set Destination IP Address, 192.168.0.100 */
    SLDIP6R[12:15] = {0xC0, 0xA8, 0x00, 0x64};
}
```

- **SOCKET-less Command**

SLCR[ARP] command transmits the ARP request.

```
{
    SLCR[ARP] = '1'; /* set ARP Command */
    while(SLCR != 0x00) ; /* Wait until ARP Command is completed*/
}
```

- **Response?**

If there is ARP response from the destination, SLIR[ARP] is set.

```
{
    /* check ARP Interrupt */
    if(SLIR[ARP] == '1') /* received ARP Reply Packet */
    {
        SLIRCLR[ARP] = '1'; /* clear Interrupt */
        goto SUCCESS;
    }
    else goto Timeout?;
```

```
}
```

- **Timeout?**

If there is no response until retransmission time expires, SLIR[TOUT] is set.

```
{
    /* check TIMEOUT Interrupt */
    if(SLIR[TOUT] == 1)
    {
        SLIRCLR[TOUT] = '1'; /* clear Interrupt */
        goto END;
    }
    else goto Response?;
}
```

- **SUCCESS**

The destination hardware address is saved in SLDHAR.

```
{
    dst_haddr [0:5] = SLDHAR[0:5]; /* get Destination hardware Address */
    goto END;
}
```

## 6.6.2 PING

SLCR[PING] transmits both ARP and PING request packet to destination IP address specified by SLDIPR. If ARP reply and PING reply are received from a destination, SLIR[PING] is set and destination hardware address is saved in SLDHAR. If there is no response until retransmission time expires, SLIR[TOUT] is set. Refer to [6.7 Retransmission](#).

- **Configuration**

Configure retransmission time, PING & TOUT interrupt mask, destination IP address and sequence number & ID of PING request packet.

```
{
START :
    /* set SOCKET-less Retransmission Time, 100ms(0x03E8)(Unit 100us) */
    //SLRTR[0:1] = { 0x03, 0xE8};
    /* set SOCKET-less Retransmission counter, 5 */
    //SLRCR = 0x05;
```

```
/* set Interrupt Mask Bit */
//SLIMR[PING] = '1'; /* PING Interrupt Mask Bit */
//SLIMR[TOU] = '1'; /* TIMEOUT Interrupt Mask Bit */

/* set Destination IP Address, 192.168.0.100 */
SLDIPR[12:15] = {0xC0, 0xA8, 0x00, 0x64};

/* set PING Sequence Number, 1000(0x03E8) */
PINGSEQR[0:1] = {0x03, 0xE8};

/* set PING ID, 256(0x0100) */
PINGIDR[0:1] = {0x01, 0x00};
}
```

- **SOCKET-less Command**

SLCR[PING] command transmits PING request packet.

```
{
    SLCR[PING] = '1'; /* set PING Command */
    while(SLCR != 0x00) ; /* Wait until PING Command is completed*/
}
```

- **Response?**

If there is PING reply packet from the destination, SLIR[PING] is set.

```
{
    /* check PING Interrupt */
    if(SLIR[PING] == '1') /* received PING Reply Packet */
    {
        SLIRCLR[PING] = '1'; /* clear Interrupt */
        goto SUCCESS;
    }
    else goto Timeout?;
}
```

- **Timeout? / SUCCESS**

Refer to [6.6.1 ARP Timeout? / SUCCESS](#)

### 6.6.3 ARP6 (ND, Neighbor Discovery)

SLCR[ARP6] transmits ICMPv6 NS (Neighbor Solicitation) packet to destination IP address specified by SLDIP6R and it is similar to ARP-process. If NA (Neighbor Advertisement) is received from destination, SLIR[ARP6] is set and destination hardware address is saved in SLDHAR. If there is no response until the retransmission time, SLIR[TOUT] is set.

Refer to [6.7 Retransmission](#).

- **Configuration**

Configure retransmission time, ARP6 & TOUT interrupt mask and destination IP address.

```
{
START :
    /* set SOCKET-less Retransmission Timer, 100ms(0x03E8) (Unit 100us) */
    //SLRTR[0:1] = {0x03, 0xE8};

    /* set SOCKET-less Retransmission Counter, 5 */
    //SLRCR = 0x05;

    /* set Interrupt Mask Bit */
    //SLIMR[ARP6] = '1'; /* ARP6 Interrupt Mask Bit */
    //SLIMR[TOUT] = '1'; /* TIMEOUT Interrupt Mask Bit */

    /* set Target IP Address, FE80::1D0:AABB:CCDD */
    SLDIP6R[0:15] = { 0xFE, 0x80, 0x00, 0x01, 0x00, 0x00, 0x00, 0x00,
                    0x13, 0x22, 0x33, 0xFF, 0xFE, 0xAA, 0xBB, 0xCC };
}
```

- **SOCKET-less Command**

SLCR[ARP6] command transmits NS packet

```
{
    SLCR[ARP6] = '1'; /* set ARP6 Command */
    while(SLCR != 0x00) ; /* Wait until ARP6 Command is completed*/
}
```

- **Response?**

If there is NA packet from the destination, SLIR[ARP6] is set.

```
{
    /* check ND Interrupt */
}
```

```
if(SLIR[ARP6] == '1') /* received NA Packet */
{
    SLIRCLR[ARP6] = '1'; /* clear Interrupt */
    goto SUCCESS;
}
else goto Timeout;
}
```

- **Timeout?**

If there is no NA packet from the destination, SLIR[TOUT] is set.

```
{
    /* check TIMEOUT Interrupt */
    if(SLIR[TOUT] == 1)
    {
        SLIRCLR[TOUT] = '1'; /* clear Interrupt */
        goto END;
    }
    else goto Response;
}
```

- **SUCCESS**

The destination hardware address is saved in SLDHAR.

```
{
    dst_haddr[0:5] = SLDHAR[0:5]; /* get Destination hardware Address */
    goto END;
}
```

#### 6.6.4 PING6 (ICMPv6 Echo)

SLCR[PING6] transmits ICMPv6 NS and PING request packet to destination IP address specified by SLDIP6R. If ICMPv6 NA and ICMPv6 Echo PING reply are received from a destination, SLIR[PING6] is set and destination hardware address is saved in SLDHAR. If there is no response until retransmission time expires, SLIR[TOUT] is set.

Refer to [6.7 Retransmission](#).

- **Configuration**

Configure retransmission, PING6 & TOUT interrupt mask , destination IP Address.

```
{
START :
    /* set SOCKET-less Retransmission Timer, 100ms(0x03E8) (unit 100us) */
    //SLRTR[0:1] = {0x03, 0xE8};

    /* set SOCKET-less Retransmission Counter, 5 */
    //SLRCR = 0x05;

    /* set Interrupt Mask Bit */
    //SLIMR[PING6] = '1'; // PING6 Interrupt Mask Bit
    //SLIMR[TOUT] = '1'; // TIMEOUT Interrupt Mask Bit

    /* set Destination IPv6 Address, FE80::1D0:AABB:CCDD */
    SLDIP6R[0:15] = { 0xFE, 0x80, 0x00, 0x01, 0x00, 0x00, 0x00, 0x00,
                    0x13, 0x22, 0x33, 0xFF, 0xFE, 0xAA, 0xBB, 0xCC };
}
```

- **SOCKET-less Command**

SLCR[PING6] command transmits NS packet and echo request packet.

```
{
    SLCR[PING6] = '1'; /* set PING6 Command */
    while(SLCR != 0x00) ; /* Wait until PING6 Command is completed*/
}
```

- **Response?**

If there is echo reply from the destination, SLIR[PING6] is set.

```
{
    /* check PING6 Interrupt */
    if(SLIR[PING6] == '1') /* received PING6 Packet */
    {
        SLIRCLR[PING6] = '1'; /* clear Interrupt */
        goto SUCCESS;
    }
    else goto Timeout?;
}
```

- **Timeout? / SUCCESS**

Refer to [6.6.3 ARP6 \(ND, Neighbor Discovery\) Timeout? / SUCCESS](#)

## 6.6.5 DAD (Duplicate Address Detection)

SLCR[NS] executes DAD (Duplicate Address Detection) mechanism to destination IP address specified by SLDI6PR. SLCR[NS] transmits DAD NS packet.

If there is DAD NA packet from a destination, SLIR[NS] is set and the destination IP address is invalid as a source IPv6 address. If there is no DAD NA packet from a destination until retransmission time expires, SLIR[TOUT] is set and the destination IP address is valid as a source IPv6 address. Refer to [6.7 Retransmission](#).

[Figure 32](#) shows the flow of DAD operation.

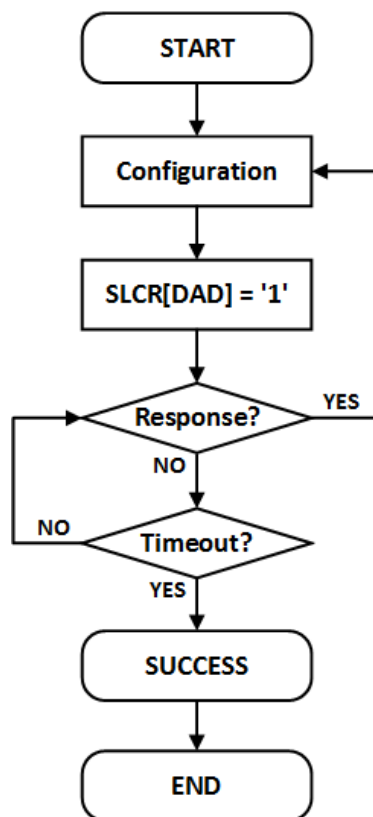

Figure 32 DAD Operation Flow

- **Configuration**

Configures retransmission time, NS & TOUT interrupt mask, and destination IP address.

```

{
START :
  /* set SOCKET-less Retransmission Timer, 100ms(0x03E8) (단위, 100us) */
  //SLRTR[0:1] = {0x03, 0xE8};

  /* set SOCKET-less Retransmission Counter, 5 */
  
```

```

////SLRCR = 0x05;

/* set Interrupt Mask Bit */
//SLIMR[NS] = '1'; /* NS Interrupt Mask Bit */
//SLIMR[TOUT] = '1'; /* TIMEOUT Interrupt Mask Bit */

/* set Target IP Address, FE80::1D0:AABB:CCDD */
SLDIP6R[0:15] = { 0xFE, 0x80, 0x00, 0x00, 0x00, 0x00, 0x00, 0x00,
                 0x00, 0x00, 0x01, 0xD0, 0xAA, 0xBB, 0xCC, 0xDD };
}

```

• **SOCKET-less Command**

SLCR[NS] transmits DAD NS packet.

```

{
    SLCR[NS] = '1'; /* set NS Command */
    while(SLCR != 0x00) ; /* Wait until NS Command is completed*/
}

```

• **Response?**

If there is DAD NA packet from the destination, SLIR[NS] is set and SLDIPR is invalid to use as source IPv6 address.

```

{
    /* check NS Interrupt */
    if(SLIR[NS] == '1') /* received DAD NA Packet */
    {
        SLIRCLR[NS] = '1'; /* clear Interrupt */
        goto Configuration;
    }
    else goto Timeout?;
}

```

• **Timeout?**

If there is no DAD NA packet received from the destination until the retransmission time expires, SLIR[TOUT] is set and it goes to SUCCESS.

```

{

```

```

/* check TIMEOUT Interrupt */
if(SLIR[TOUT] == 1)
{
    SLIRCLR[TOUT] = '1'; /* clear Interrupt */
    goto SUCCESS;
}
else goto Response?;
}

```

• SUCCESS

SLDIP6R can be used as source IPv6 address.

```

{
    LLAR[0:15] = SLDIP6R[0:15]; /* get Source Link-Local Address */
    goto END;
}

```

### 6.6.6 RS (Router Solicitation)

SLCR[RS] transmits RS (Router Solicitation) packet to link local all-router multicast address (FF02::2). If there is an RA packet from a Router, SLIR[RS] is set and prefix length, flags, valid lifetime, prefix life time, and prefix address of the RA packet are saved in PLR, PFR, VLTR, PLTR and PAR, respectively. If there is no RA packet from router until retransmission time expires, SLIR[TOUT] is set. Refer to [6.7 Retransmission](#).

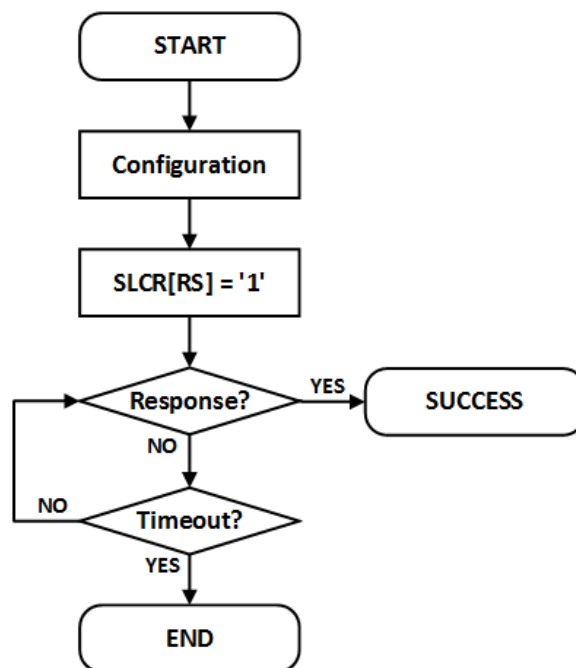

Figure 33 RS Operation Flow

**\*CAUTION** : PLR, PFR, VLTR, PLTR, and PAR values are not processed properly when RA is received but the first type of RA Option Field is not source link-layer address (0x01) and the second type is not Prefix Information (0x03).

In this case, use IPRAW6 SOCKET to receives data of RA.

- **Configuration**

Configure retransmission time, RS & TOUT interrupt mask , router IP address.

```
{
START :
    /* set SOCKET-less Retransmission Timer, 100ms(0x03E8) (단위, 100us) */
    //SLRTR[0:1] = {0x03, 0xE8};
    /* set SOCKET-less Retransmission Counter, 5 */
    //SLRCR = 0x05;

    /* set Interrupt Mask Bit */
    //SLIMR[RS] = '1'; // RS Interrupt Mask Bit
    //SLIMR[TOUT] = '1'; // TIMEOUT Interrupt Mask Bit
}
```

- **SOCKET-less Command**

SLCR[RS] transmits RS packet.

```
{
    SLCR[RS] = '1'; /* set RS Command */
    while(SLCR != 0x00) ; /* Wait until RS Command is completed*/
}
```

- **Response?**

If there is RA packet from a router, SLIR[RS] is set.

```
{
    /* check RS Interrupt */
    if(SLIR[RS] == '1') /* received RA Packet */
    {
        SLIRCLR[RS] = '1'; /* clear Interrupt */
        goto Configuration;
    }
    else goto Timeout?;
}
```

- **Timeout?**

If there is no RA packet during retransmission time, SLIR[TOUT] is set.

```
{
    /* check TIMEOUT Interrupt */
    if(SLIR[TOUT] == 1)
    {
        SLIRCLR[TOUT] = '1'; /* clear Interrupt */
        goto SUCCESS;
    }
    else goto Response?;
}
```

- **SUCCESS**

Prefix length, flags, valid lifetime, prefix lifetime, and prefix address of the RA packet are saved in PLR, PFR, VLTR, PLTR, and PAR, respectively.

```
{
    Prefix_length = PLR; /* RA Prefix Length */
    Flags = RAFLGR; /* RA Flags */
    Valid_Lifetime = VLTR; /* RA Valid Life Time */
    Prefix_Lifetime = PLTR; /* RA Prefix Life Time */
    Prefix_address[0:15] = PAR[0:15]; /* RA Prefix Address */
}
```

### 6.6.7 Unsolicited NA(Neighbor Advertisement)

SLCR[NA] transmits unsolicited NA packet. Destination address is automatically configured FF02::1(All-Node Multicast Address) and Target address is automatically configured by LLAR or GUAR according to SLPR.

Because Unsolicited NA is an unresponsive message, SLIR [TIOU] is set when the transmission is completed.

*Figure 34* shows the flow of unsolicited NA operation.

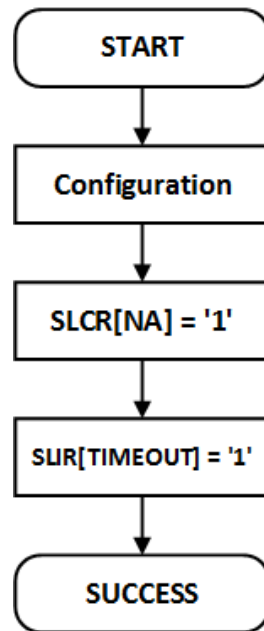

Figure 34 Unsolicited NA Operation Flow

- **Configuration**

Configure target address, address type and TOUT interrupt mask.

```

{
START :
  if (Target Address is Link Local Address)
  {
    LLAR[0:15] = { 0xFE, 0x80, 0x00, 0x00, 0x00, 0x00, 0x00, 0x00,
                  0x00, 0x00, 0x00, 0x00, 0x00, 0x12, 0x34, 0x56 };
    SLPR = 0x10;
  }
  else /* Target Address is Global Unicast Address */
  {
    GUAR[0:15] = { 0x20, 0x01, 0x00, 0x00, 0x00, 0x00, 0x00, 0x00,
                  0x00, 0x00, 0x00, 0x00, 0x00, 0x12, 0x34, 0x56 };
    SLPR = 0x11;
  }

  /* set SOCKET-less TIMEOUT Interrupt Masking bit */
  SLIMR[TOUT] = '1';
}
  
```

- **SOCKET-less Command**

SLCR[NA] transmits unsolicited NA packet to all-node.

```
{
    SLCR[NA] = '1'; /* set Unsolicited NA Command */
    while(SLCR != 0x00) ; /* Wait until Unsolicited NA Command is completed*/
}
```

- **Timeout**

SLIR[TOUT] is set when the transmission is completed.

```
{
    /* check TIMEOUT Interrupt */
    if(SLIR[TOUT] == 1)
    {
        SLIRCLR[TOUT] = '1'; /* clear Interrupt */
        goto SUCCESS;
    }
}
```

## 6.7 Retransmission

### 6.7.1 ARP & PING & ND Retransmission

When there is no response from a destination against of ARP/PING/ND Packet, ARP/PING/ND retransmission is performed. In retransmission process, the request packet is retransmitted every RTR until the response packet is received. And if the count of retransmission exceeds RCR, TIMEOUT occurs. The below table shows retransmission TIMEOUT ( $ARP_{TO}$ ,  $PING_{TO}$ ,  $ND_{TO}$ ).

$$ARP_{TO}, PING_{TO}, ND_{TO} = (TIMEOUT_{VAL} \times 0.1ms) \times (TIMEOUT_{CNT} + 1)$$

$$TIMEOUT_{VAL} = SLRTR \text{ or } S_n\_RTR$$

$$TIMEOUT_{CNT} = SLRCR \text{ or } S_n\_RCR$$

Ex)  $TIMEOUT_{VAL} = 2000(0x07D0)$ ,  $TIMEOUT_{CNT} = 7(0x0007)$

$$ARP_{TO} = 2000 \times 0.1ms \times (7+1) = 1.6s$$

$ARP_{TO}$  occurs when there is no response from a destination in ARP-process by  $S_n\_CR$  [CONNECT] in TCP4 mode,  $S_n\_CR$ [SEND] in UDP4 & IPRAW4 mode, and SLCR[ARP] in SOCKET-less command.  $S_n\_IR$ [TIMEOUT] or SLIR[TOUT] is set by  $ARP_{TO}$ .

$PING_{TO}$  occurs when there is no response from a destination in ARP-process by SLICR[PING] and SLICR[PING6] or no PING reply from a destination after ARP-process.

SLIR[TOOUT] is set by  $PING_{TO}$ .

$ND_{TO}$  occurs in the ND process by Sn\_CR[CONNECT6] in TCP6 & TCPD mode, Sn\_CR[SEND6] in UDP6 & UDPD & IPRAW6 mode, SLICR[ARP6] & SLICR[NS] & SLICR[RS] in SOCKET-less command. Sn\_IR[TIMEOUT] or SLIR[TOOUT] is set by  $ND_{TO}$ .

## 6.7.2 TCP Retransmission

When TCP mode SOCKET doesn't receive ACK packet from a destination against of SYN, FIN, or DATA packet sent, TCP retransmission is performed. In TCP retransmission process, the packet is retransmitted every Sn\_RTR until ACK packet from the destination is received. And if the count of retransmission exceeds Sn\_RCR, SOCKET n TIMEOUT occurs.

The below table shows the TCP Retransmission TIMEOUT ( $TCP_{TO}$ ).

$$TCP_{TO} = \left( \sum_{N=0}^M (TIMEOUT_{VAL} \times 2^N) + ((TIMEOUT_{CNT} - M) \times TIMEOUT_{MAXVAL}) \right) \times 0.1ms$$

N : Retransmission Counter,  $0 \leq N \leq M$

M : Minimum value of  $TIMEOUT_{VAL} \times 2^{(M+1)} > 65535$  and  $0 \leq M \leq TIMEOUT_{CNT}$

$TIMEOUT_{VAL} = Sn\_RTR$

$TIMEOUT_{CNT} = Sn\_RCR$

$TIMEOUT_{MAXVAL} : TIMEOUT_{VAL} \times 2^M$

Ex) RTR = 2000(0x07D0), RCR = 7(0x0007)

$$\begin{aligned} TCP_{TO} &= (0x07D0+0x0FA0+0x1F40+0x3E80+0x7D00+0xFA00+0xFA00) \times 0.1ms \\ &= (2000 + 4000 + 8000 + 16000 + 32000 + ((7 - 5) \times 64000)) \times 0.1ms \\ &= 190000 \times 0.1ms = 19.0s \end{aligned}$$

$TCP_{TO}$  occur by CONNECT, CONNECT6, SEND, SEND6, and DISCON command in Sn\_CR, and Sn\_IR [TIMEOUT] is set by  $TCP_{TO}$ .

## 6.8 Others Functions

### 6.8.1 System Clock(SYS\_CLK) Switching

SYS\_CLK operates in 25MHz or 100MHz and can be set by SYCR1[CLKSEL], PHYCR1[RST], or PHYCR1[PWDN]. When clock switching happens, it takes time until SYS\_CLK becomes stable. Refer to [6.7 Retransmission](#).

SYCR1[CLKSEL]	PHYCR1[RST]	PHYCR1[PWDN]	SYS_CLK(MHz)
0	0	X	25
0	1	0	100 (Default)
0	1	1	25
1	X	X	25

### 6.8.2 Ethernet PHY Operation Mode Configuration

PHY operation mode (Speed, Duplex) is set by PHYCR0 and it becomes valid after Ethernet PHY HW reset. PHY operation mode can be checked with PHYSR[5:3] and link state with PHYSR[2:0] after Ethernet PHY link up.

PHYCR0 can be configured only when PHYLCKR is unlocked.

Ex) Setting PHY Operation Mode

```

PHY_10FDX :
{
    /* PHYCR0 & PHYCR1 Unlock */
    PHYLCKR = 0x53;

    /* Set PHYCR0 100/10BASE & Full/Duplex */
    phy_mode = '000' // Auto Negotiation
    //phy_mode = '100' // 100BASE-TX FDX
    //phy_mode = '101' // 100BASE-TX HDX
    //phy_mode = '110' // 10BASE-TX FDX
    //phy_mode = '111' // 10BASE-TX HDX
    PHYCR0[2:0] = phy_mode;

    /* PHY Reset Process */
    PHYCR1[RST] = '1';
    Wait TPRST; // refer to 8.4.1 Reset Timing

    /* PHYCR0 & PHYCR1 Lock */
    PHYLCKR = 0x00; // for Lock, write any value

```

```

/* wait until PHY Link is up */
while(PHYSR[LNK] != '0');

/* read PHYSR */
If( (PHYSR[5:3] == phy_mode) ) SUCCESS;
else FAIL;
}

```

### 6.8.3 Ethernet PHY Parallel Detection

If the link partner doesn't support auto-negotiation, embedded Ethernet PHY of W6100 makes a link via parallel detection.

**\*CAUTION** The duplex mode mismatch like 10F/10H may decrease the network performance.

PHY \ Link Partner	Auto	10H	10F	100H	100F
Auto	100F 100F	10H 10H	10F 10H	100H 100H	100F 100H
Manual 10H	10H 10H	10H 10H	10F 10H		
Manual 10F	10F 10F	10H 10F	10F 10F		
Manual 100H	100H 100H			100H 100H	100F 100F
Manual 100F	100F 100F			100H 100F	100F 100F

### 6.8.4 Ethernet PHY Auto MDIX

W6100 supports auto-MDIX when Ethernet PHY is set as auto-negotiation (PHYCR0[MODE2] = '0'), symmetric transformer (Figure 43 Transformer Type) is used in this case.

Without auto-negotiation, auto-MDIX cannot be supported, hence cross UTP cable should be used.

**\*CAUTION** : If any mode among all nodes make link support auto-MDIX, then both straight or cross UTP cable can be used.

### 6.8.5 Ethernet PHY Power Down Mode

In case of PHYCR1[PWDN] = '1', Ethernet PHY enters power down mode and SYS\_CLK is changed to 25MHz.

In case of PHYCR1[PWDN] = '0', Ethernet PHY enter normal mode and SYS\_CLK is selected by SYCR1[CLKSEL].

Refer to [4.1.5 SYCR1 \(System Config Register 1\)](#).

Enter Power Down mode :

```
{
    /* PHYCR0 & PHYCR1 Unlock */
    PHYLCKR = 0x53;

    /* Enable Power Down Mode */
    PHYCR1[PWDN] = '1';

    /* PHYCR0 & PHYCR1 Lock */
    PHYLCKR = 0x00; // for Lock, write any value

    /* wait until clock is stable switched */
    Wait TPRST; // refer to 8.4.1 Reset Timing
}
```

Exit Power Down mode :

```
{
    /* PHYCR0 & PHYCR1 Unlock */
    PHYLCKR = 0x53;

    /* enable Power Down Mode */
    PHYCR1[PWDN] = '0';

    /* PHYCR0 & PHYCR1 Lock */
    PHYLCKR = 0x00; // for Lock, write any value

    /* wait until Clock is stable switched */
    Wait TPRST; // refer to 8.4.1 Reset Timing

    /* wait until Clock is switched 25 to 100MHz*/
    Wait TLF; // refer to 8.4.1 Reset Timing
}
```

## 6.8.6 Ethernet PHY's Registers Control

Ethernet PHY registers can be accessed via MDC/MDIO (Management Data Clock/Input Output) interface. W6100 integrates MDC/MDIO controller and the HOST controls it through PHYDIVR, PHYRAR, PHYDOR, PHYDIR, and PHYACR.

Figure 35 shows MDC/MDIO Write Control Flow.

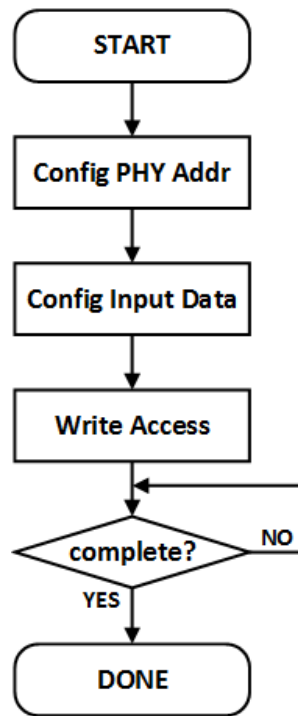

Figure 35 MDC/MDIO Write Control Flow

- **Config PHY Register Address**

Store the address of PHY register to access into PHYRAR.

```

{
START :
    /* set PHY Register Address into PHYRAR */
    PHYRAR = 0x00; /* BMCR Address is 0x00 */
}
  
```

- **Config Input Data**

Store 16bits data which to write to PHY register into PHYDIRO & PHYDIR1.

The most significant 8 bits data in PHYDIR1 / the least significant 8 bits data in PHYDIRO.

```

{
    /* declare 16bits variable */
}
  
```

```

Data = 0x8000; /* set RST bit in BMCR */

PHYDIR1 = (Data & 0xFF00) >> 8; /* set upper 8bits Data */
PHYDIR0 = Data & 0x00FF; /* set lower 8bits Data */
}

```

• **Write Access / Complete?**

If PHYACR is set to '0x01', data in PHYDIR is written to PHY register, which is designated in PHYRAR. PHYACR will be cleared automatically.

```

{
PHYACR = 0x01; /* set Write Access */
while(PHYACR != 0); /* wait until MDC/MDIO Control is complete */
}

```

Figure 36 shows MDC/MDIO Read Control Flow.

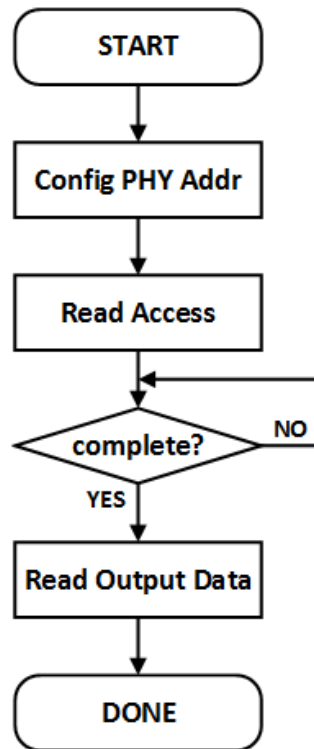

Figure 36 MDC/MDIO Read Control Flow

• **Config PHY Register Address**

Stores the address of PHY register to access into PHYRAR.

```

{
START :
/* set PHY Register Address into PHYRAR */
}

```

```
PHYRAR = 0x01; /* BMSR Address is 0x01 */  
}
```

- **Read Access / Complete?**

If PHYACR is set to '0x02', data in PHY register, which is designated in PHYRAR, transfers to PHYDOR. PHYACR will be cleared automatically.

```
{  
    PHYACR = 0x02; /* set Read Access */  
    while(PHYACR != 0); /* wait until MDC/MDIO Control is complete */  
}
```

- **Read Output Data**

Data in PHY register is stored to PHYDOR0 & PHYDOR1.

The most significant 8 bits in PHYDOR1 / the least significant 8 bits in PHYDOR0.

```
{  
    Data = (PHYDOR1 & 0x00FF) << 8; /* get upper 8bits Data */  
    Data = Data + (PHYDOR0 & 0x00FF); /* get lower 8bits Data */  
}
```

## 6.8.7 Ethernet PHY 10BASE-Te Mode

W6100 Ethernet PHY can operate in 10BASE-Te mode and below is the setting procedure.

```
{  
    /* PHYCRO&PHYCR1 Unlock */  
    PHYLCKR = 0x53;  
  
    /* Enable Auto-negotiation */  
    PHYCRO[2:0] = '000';  
  
    /* set PHY Te Mode */  
    PHYCR1[TE] = '1';  
  
    /* PHY Reset Process */  
    PHYCR1[RST] = '1';  
    Wait TPRST; // refer to 8.4.1 Reset Timing  
}
```

## 7. Clock & Transformer Requirements

### 7.1 Quartz Crystal Requirements.

Table 10 Quartz Crystal

Parameter	Condition / Description	Min	Typ	Max	Unit
Frequency(F)			25		MHz
Frequency Tolerance	At 25°C	-50		+50	ppm
Frequency Stability	1 Year aging.	-50		+50	ppm
Load Capacitance (C <sub>L</sub> )	ESR = 30 Ω		12		pF
Feedback Resistor (R <sub>F</sub> )	External resistor		1M		Ω
Startup time	W6100 Reset			60	ms
Trans-conductance(g <sub>m</sub> )			16.7		mA/V
Gain Margin (gain <sub>margin</sub> )	gain <sub>margin</sub> = g <sub>m</sub> / g <sub>mcrit</sub>	6.99			dB

$C_0^{(1)}$  : The Packaging Parasitic Shunt Capacitance.

$C_L^{(1)}$  : Load Capacitance. eq)  $C_L = (C_{L1} \times C_{L2}) / (C_{L1} \times C_{L2}) + C_s$

$C_{L1}, C_{L2}$  : External Capacitances of the circuit connected to the crystal (Typically,  $C_{L1} = C_{L2}$ )

$C_s$  : Stray Capacitance of printed circuit board and connections.

$g_{mcrit}$  : Oscillator loop critical gain. eq)  $g_{mcrit} = 4 \times (ESR + R_{Ext}) \times (2\pi F)^2 \times (C_0 + C_L)^2$

$ESR^{(1)}$  : Maximal equivalent series resistance. eq)  $ESR = R_m \times (1 + C_0/C_L)^2$

$R_{Ext}$  : Resistor for limiting the drive level(DL) of the crystal.

$DL^{(1)}$  : The power dissipated in the crystal. Excess power can destroy the crystal.

$R_F^{(2)}$  : Feedback resistor.

- $C_0, C_L, ESR$  and  $DL$  are provided by the crystal manufacturer.
- The W6100 has no feedback resistor. Therefore, it must be inserted outside.

\* Figure 37 shows Crystal circuit modeling.

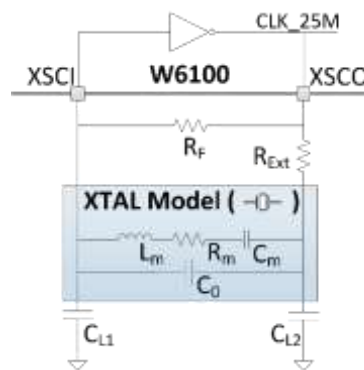

Figure 37 Quartz Crystal Model

Table 11 Crystal Recommendation Characteristics

Parameter	Range
Frequency	25 MHz
Frequency Tolerance (at 25°C)	±30 ppm
Shunt Capacitance	7pF Max

Drive Level	500uW
Load Capacitance	12pF
Aging (at 25°C)	±3ppm / year Max

## 7.2 Oscillator requirements.

Table 12 Oscillator Characteristics

Parameter	Condition / Description	Min	Typ	Max	Unit
Frequency		25			MHz
Frequency Tolerance	At 25°C	-50		+50	ppm
Frequency Stability	1 Year aging. 25°C	-50		+50	ppm
Clock Duty	50% of waveform	45	50	55	%
Input High Voltage		-	0.97	-	V
Input Low Voltage		-	0.13	-	V
Rise/Fall Time	10% to 90% of waveform			8ns	
Start Up Time		-	-	10ms	
Operating Voltage		1.08V	1.2V	1.32V	
Aging (at 25°C)		±3 / year Max			ppm

## 7.3 Transformer Characteristics

Table 13 Transformer Characteristics

Parameter	Transmit End	Receive End
Turn Ratio	1:1	1:1
Inductance	350 uH	350 uH

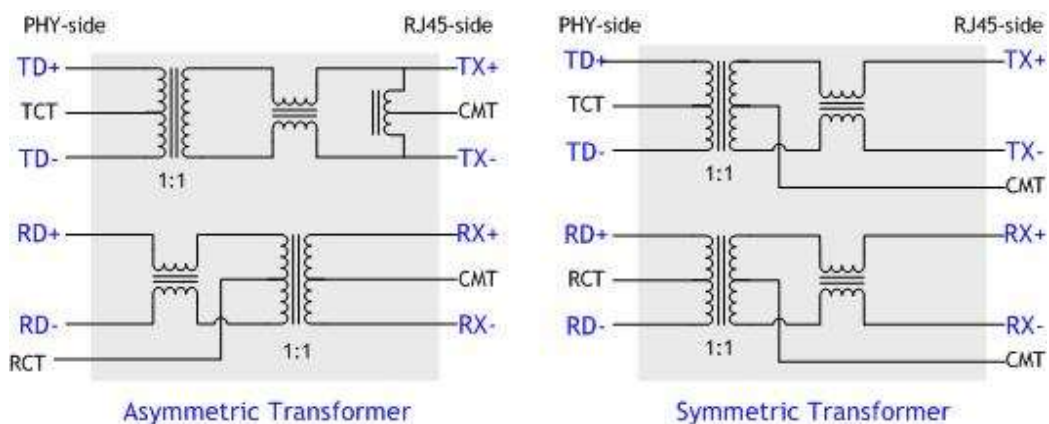

Figure 38 Transformer Type

## 8. Electrical Specification

### 8.1 Absolute Maximum ratings

Table 14 Absolute Maximum ratings

Symbol	Parameter	Rating	Unit
V <sub>DD</sub>	DC Supply voltage	-0.5 to 4.6	V
V <sub>IN</sub>	DC input voltage	-0.5 to 4.6	V
V <sub>OUT</sub>	DC output voltage	-0.5 to 3.63	V
I <sub>IN</sub>	DC input current	20	mA
T <sub>OP</sub>	Operating temperature	-40 to +85	°C
T <sub>JMAX</sub>	Maximum junction temperature	125	°C
T <sub>STG</sub>	Storage temperature	-65 to +150	°C

**\*COMMENT:** *Stressing the device beyond the ‘Absolute Maximum Ratings’ may cause permanent damage.*

### 8.2 Absolute Maximum ratings (Electrical Sensitivity)

Table 15 Electro Static Discharge (ESD)

Symbol	Parameter	Test Condition	Class	Maximum value(1)	Unit
V <sub>ESD HBM</sub>	Electrostatic discharge voltage (human body model)	TA = +25 °C conforming to MIL-STD 883F Method 3015.7	2	2000	V
V <sub>ESD MM</sub>	Electrostatic discharge voltage (man machine model)	TA = +25 °C conforming to JEDEC EIA/JESD22 A115-A	B	200	V
V <sub>ESD CDM</sub>	Electrostatic discharge voltage (charge device model)	TA = +25 °C conforming to JEDEC JESD22 C101-C	III	500	V

Table 16 Latch up Test

Test Condition	Class	Maximum value	Unit
TA = +25 °C conforming to JESD78	Current	≥ ±100	mA
	Voltage	≥ 1.5*V <sub>DD</sub>	V

## 8.3 DC Characteristics

Table 17 DC Characteristics

(Test Condition:  $T_a = -40$  to  $85^\circ\text{C}$ )

Symbol	Parameter	Test Condition	Min	Typ	Max	Unit
$V_{DD}$	Supply voltage	Apply VDD, AVDD	2.97	3.3	3.63	V
$V_{IH}$	High level input voltage		2.0	-	-	V
$V_{IL}$	Low level input voltage		-		0.8	V
$V_{T+}$	Schmitt trig Low to High Threshold point	All inputs except Analog PINs	0.8	1.1	-	V
$V_{T-}$	Schmitt trig High to Low Threshold point	All inputs except Analog PINs	-	1.6	2.0	V
$T_J$	Junction temperature		-40	25	125	$^\circ\text{C}$
$I_L$	Input Leakage Current			$\pm 1$	$\pm 10$	$\mu\text{A}$
$R_{PU}$	Pull-up Resistor		40	75	190	$\text{K}\Omega$
$R_{PD}$	Pull-down Resistor		30	75	190	$\text{K}\Omega$
$V_{OL}$	Low level output voltage	IOL = 2.0mA ~ 8.0mA All outputs except XSCO			0.4	V
$V_{OH}$	High level output voltage	IOH = 2.0m ~ 8.0mA, All outputs except XSCO	2.4			V

## 8.4 AC Characteristics

### 8.4.1 Reset Timing

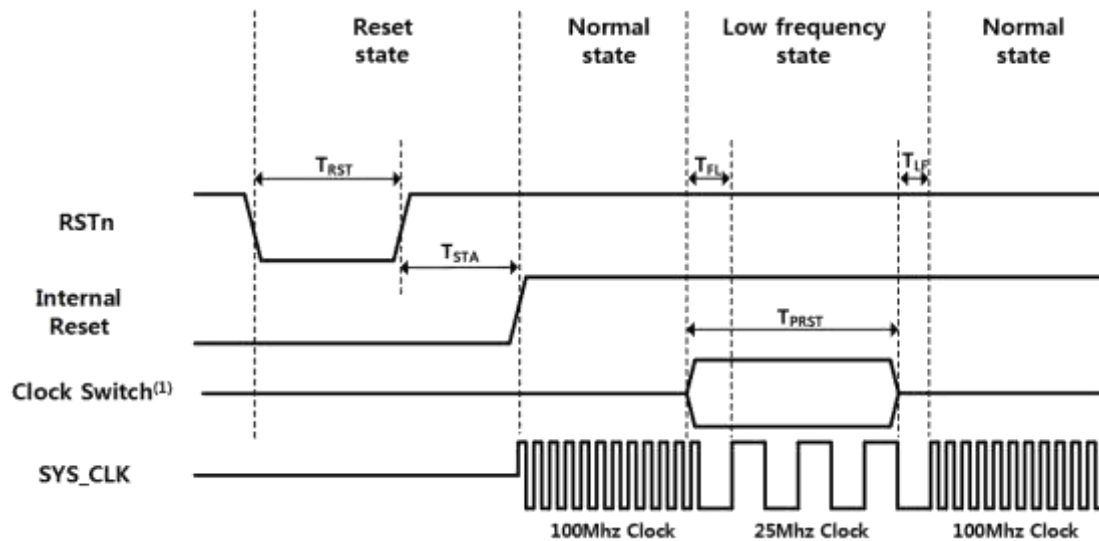

Figure 39 Reset Timing

Table 18 Reset Table

Symbol	Description	Min	Typ	Max
$T_{RST}$	Reset Time	350 ns	580 ns	1.0 us
$T_{STA}$	Stable Time	-		60.3 ms
$T_{FL}$	Fast to Low Time by MR2[CLKSEL]	100 ns		-
	Fast to Low Time by PHYCR1[RST] or PHYCR1[PWDN]	300 ns		
$T_{PRST}$	PHY Auto Reset Time	0.6 ms		-
	PHY Power Down Time	200 us		
	Clock Switch Time	200 ns		
$T_{LF}$	Low to Fast Time by MR2[CLKSEL]	100 ns		-
	Low to Fast Time by PHYCR1[RST] or PHYCR1[PWDN]	100 ns		

**\*COMMENT:** PHY power-down mode has  $T_{FL}$  and  $T_{LF}$  (In PHY power-down mode, SYS\_CLK switches to low clock. After  $T_{FL}$ , users can disable PHY power-down mode.

**\*CAUTION:** Users must not set PHY auto reset and PHY power-down mode at the same time.

## 8.4.2 BUS ACCESS TIMING

### 8.4.2.1 READ TIMING

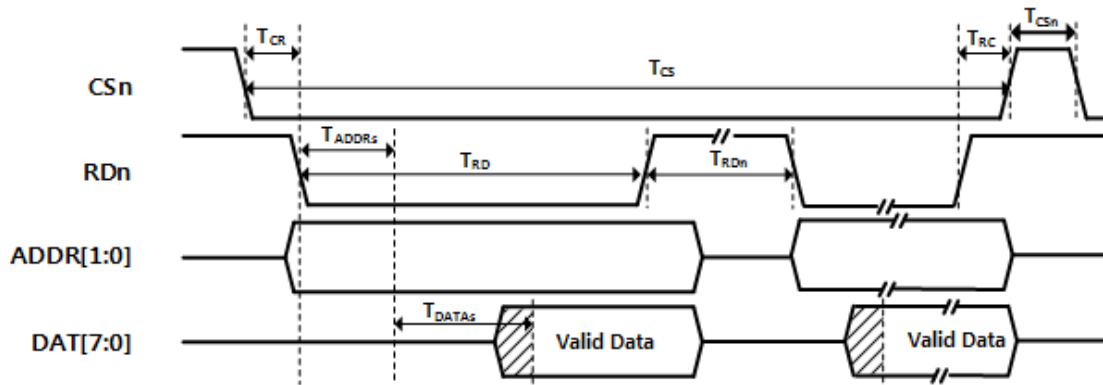

Figure 40 BUS Read Timing

Table 19 BUS Read Timing

Symbol	Description	Min	Max
$T_{ADDRS}$	Address Setup Time	SYS_CLK	
$T_{CR}$	CSn Low to /RD Low Time	0 ns	
$T_{CS}$	CSn Low Time	4 SYS_CLK	
$T_{RC}$	RDn High to CSn High Time	0 ns	
$T_{CSn}$	CSn Next Assert Time	3 SYS_CLK	
$T_{RD}$	RDn Low Time	4 SYS_CLK	
$T_{RDn}$	RDn Next Assert Time	3 SYS_CLK	
$T_{DATAS}$	Data Setup Time	3 SYS_CLK+5ns	

### 8.4.2.2 WRITE TIMING

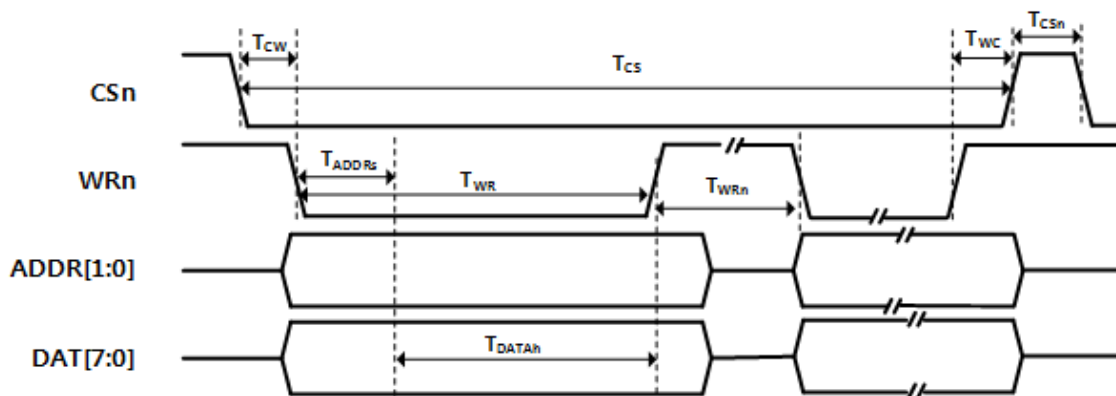

Figure 41 BUS Write Timing

Table 20 BUS Write timing

Symbol	Description	Min	Max
$T_{ADDRs}$	Address Setup Time	SYS_CLK	
$T_{CW}$	CSn Low to WRn Low Time	0 ns	
$T_{cs}$	CSn Low Time	4 SYS_CLK	
$T_{WC}$	WRn High to CSn High Time	0 ns	
$T_{csn}$	CSn Next Assert Time	3 SYS_CLK	
$T_{WR}$	WRn Low Time	4 SYS_CLK	
$T_{WRn}$	WRn Next Assert Time	3 SYS_CLK	
$T_{DATAs}$	Data Setup Time	2 SYS_CLK	

### 8.4.3 SPI ACCESS TIMING

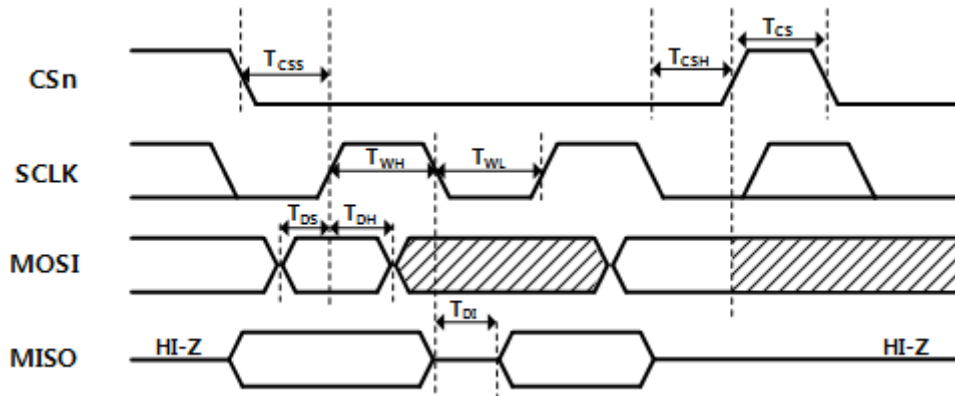

Figure 42 SPI Access Timing

Table 21 SPI Access Timing

Symbol	Description	Min	Max	Units
$F_{SCLK}$	SCLK Clock Frequency		70	MHz
$T_{CSS}$	CSn Setup Time	3 SYS_CLK		ns
$T_{CSH}$	CSn Hold Time	2 SYS_CLK		ns
$T_{CS}$	CSn High Time	2 SYS_CLK		ns
$T_{WH}$	SCLK High time	3		ns
$T_{WL}$	SCLK Low Time	3		ns
$T_{DS}$	Data Setup Time	3		ns
$T_{DH}$	Data In Hold Time	3		ns
$T_{DI}$	Data Invalid Time	7		ns

## 8.4.4 Transformer Characteristics

Table 22 Transformer Characteristics

Parameter	Transmit End	Receive End
Turn Ratio	1:1	1:1
Inductance	350 uH	350 uH

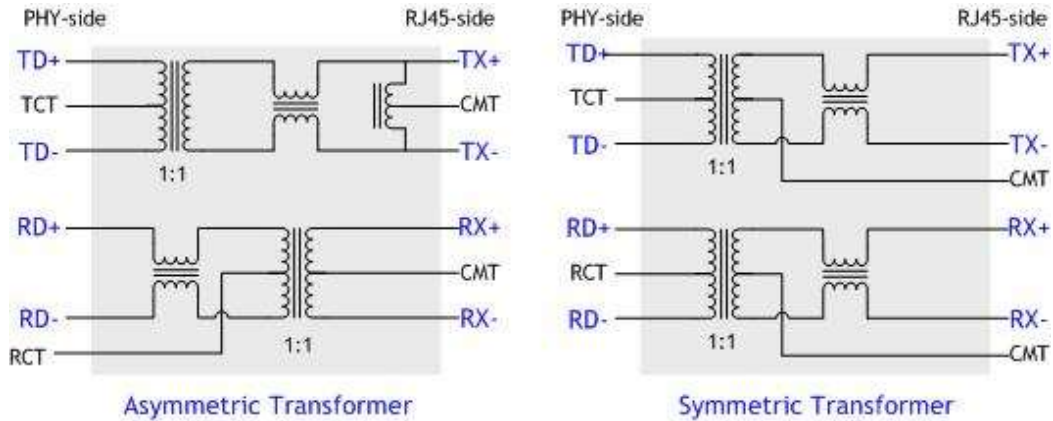

Figure 43 Transformer Type

## 8.4.5 MDIX

W6100 supports Auto-MDIX only when W6100 is in Auto-negotiation mode.

## 8.5 POWER DISSIPATION

Table 23 Power Dissipation

(Test Condition: VDD=3.3V, AVDD=3.3V, Ta = 25 °C)

Condition	Min	Typ	Max	Unit
100M Link	-	98	115	mA
10M Link	-	112	265	mA
10M-Te Link	-	75	190	mA
100M Unlink (actual measurement)	-	50	199	mA
10M Unlink (actual measurement)	-	26	170	mA
10M-Te Unlink (actual measurement)	-	26	130	mA
Un-Link (Auto-negotiation mode) (actual measurement)	-	50	199	mA
Power Down mode	-	14	20	mA

## 9. Package Information

### 9.1 LQFP48

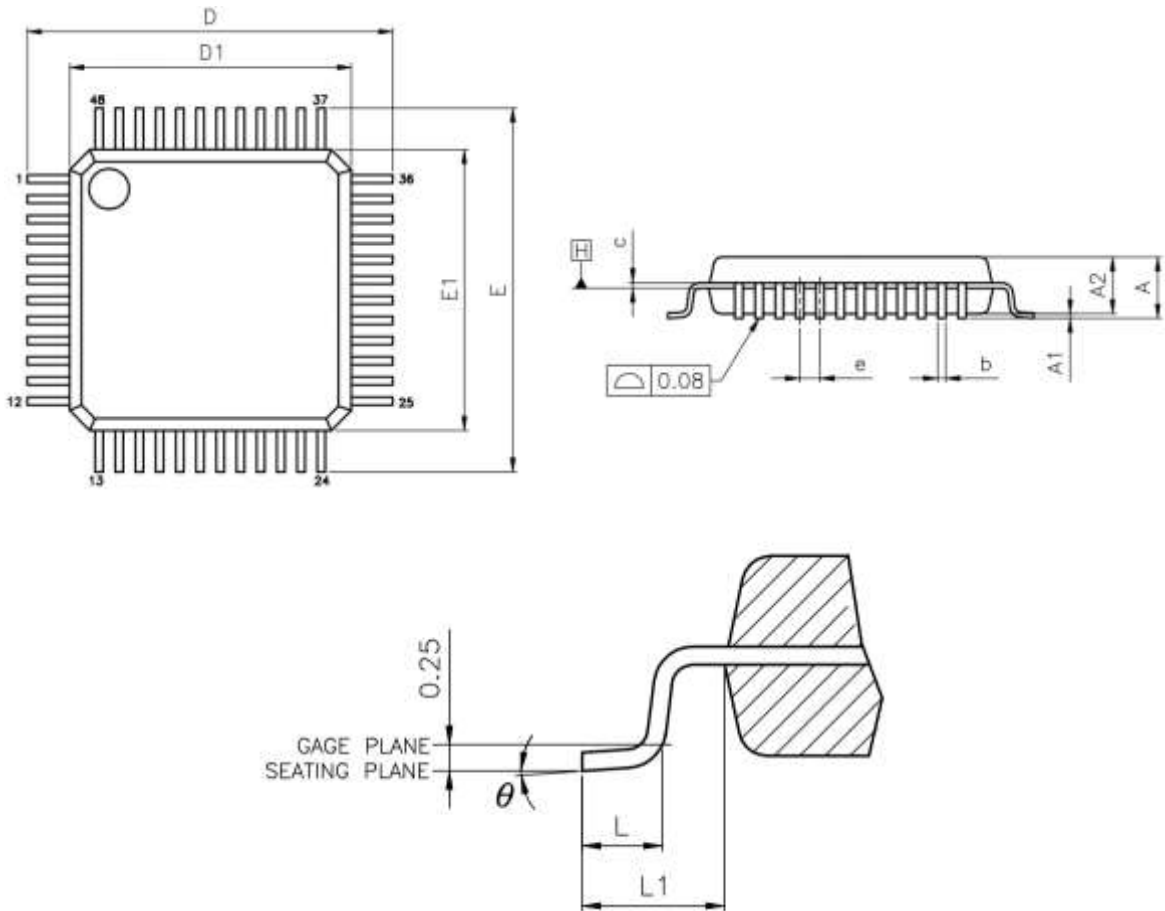

Table 24 LQFP48 VARIATIONS (ALL DEMINIONS SHOWN IN MM)

SYMBOL	MIN	NOM	MAX
A	--	--	1.60
A1	0.05	--	0.15
A2	1.35	1.40	1.45
b	0.17	0.22	0.27
c	0.09	--	0.20
D	9.00 BSC		
D1	7.00 BSC		
E	9.00 BSC		
E1	7.00 BSC		
e	0.50 BSC		
L	0.45	0.60	0.75
L1	1.00 REF		
$\theta$	0°	3.5°	7°

**NOTES:**

1. JEDEC OUTLINE:  
MS-026 BBC  
MS-026 BBC-HD (THERMALLY ENHANCED VARIATIONS ONLY)
2. DATUM PLANE  $\square$  IS LOCATED AT THE BOTTOM OF THE MOLD PARTING LINE COINCIDENT WITH WHERE THE LEAD EXITS THE BODY
3. DIMENSIONS D1 AND E1 DO NOT INCLUDE MOLD PROTRUSION. ALLOWABLE PROTRUSION IS 0.25 mm PER SIDE. DIMENSIONS D1 AND E1 DO INCLUDE MOLD MISMATCH AND ARE DETERMINED AT DATUM PLANE  $\square$ .
4. DIMENSION  $b$  DOES NOT INCLUDE DAMBAR PROTRUSION.

## 9.2 QFN48

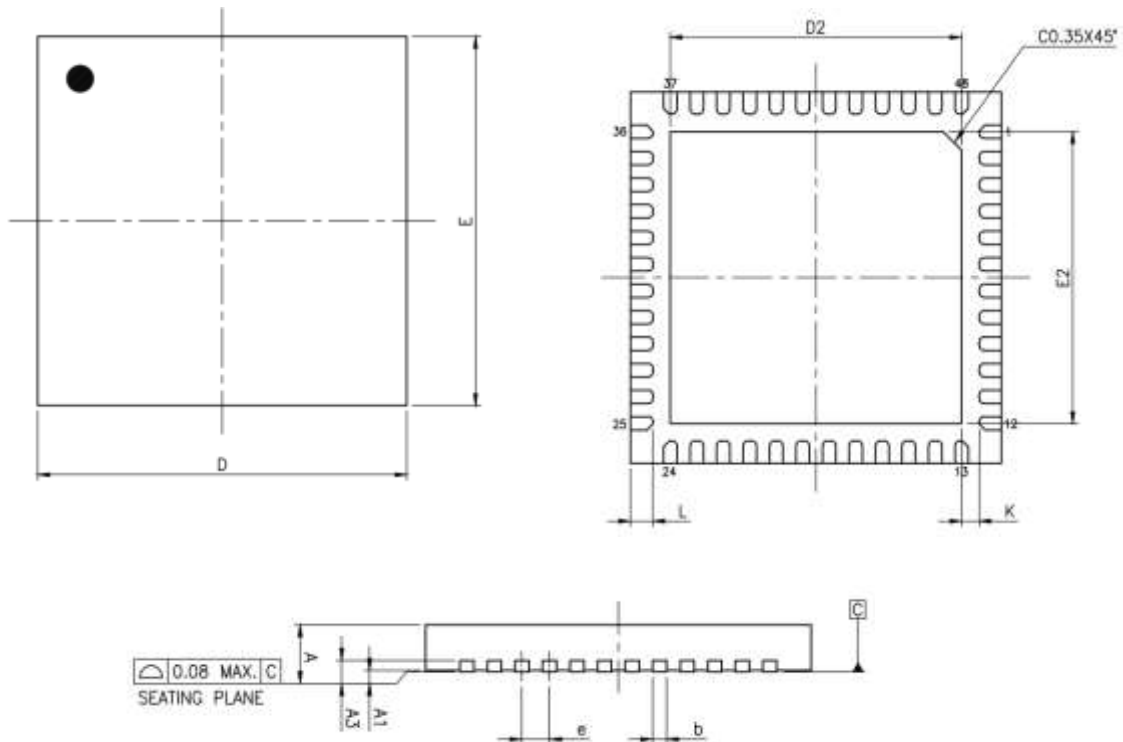

Table 25 QFN48 VARIATIONS (ALL DEMINSIONS SHOWN IN MM)

SYMBOL	MIN	NOM	MAX	
A	0.70	0.75	0.80	
A1	0.00	0.02	0.05	
A3	0.203 REF			
b	0.20	0.25	0.30	
D	7.00 BSC			
E	7.00 BSC			
e	0.50 BSC			
D2	5.25	5.30	5.35	
E2	5.25	5.30	5.35	
L	0.35	0.40	0.45	
K	0.20	--	--	
LEAD FINISH	Pure Tin	V	PPF	X
JEDEC CODE	N/A			

### NOTES:

1. ALL DIMENSIONS ARE IN MILLIMETERS
2. DIMENSION B APPLIES TO METALLIZED TERMINAL AND IS MEASURED BETWEEN 0.15mm AND 0.30mm FROM THE TERMINAL TIP. IF THE TERMINAL HAS THE OPTIONAL RADIUS ON THE OTHER END OF THE TERMINAL, THE DIMENSION b SHOULD NOT BE MEASURED IN THAT RADIUS AREA.
3. BILATERAL COPLANARITY ZONE APPLIES TO THE EXPOSED HEAT SINK SLUG AS WELL AS THE TERMINALS.

## 10. Document Revision History

Version	Date	Descriptions
Ver. 1.0.0	1FEB2019	Initial Release
Ver. 1.0.1	7MAR2019	1.Modified Power Dissipation (in <a href="#">8.5 POWER DISSIPATION</a> )
Ver. 1.0.2	15MAY2019	1. Added Maximum junction temperature (in <a href="#">8.1 Absolute Maximum ratings</a> )
Ver. 1.0.3	8OCT2019	Modified Hyperlink about “Clock Selection Guide” in page 13
Ver. 1.0.4	28OCT2019	Modified MACRAW Mode Value from ‘0100’ to ‘0111’
Ver. 1.0.5	17MAY2022	Corrected RCR reset value ‘0x07 -> 0x08’ (in <a href="#">4.1.63RCR (Retransmission Count Register)</a> ) and modified related examples ( <a href="#">6.7.1 ARP &amp; PING &amp; ND Retransmission</a> , <a href="#">6.7.2 TCP Retransmission</a> )

## Copyright Notice

Copyright 2019 WIZnet Co., Ltd. All Rights Reserved.

Technical Support: <https://forum.wiznet.io/>

Docs :<https://docs.wiznet.io/>

Sales & Distribution: <mailto:sales@wiznet.io>

For more information, visit our website at <https://www.wiznet.io/>





## Looking for pricing, stock, or lifecycle information?

Click below to explore more details on WIN SOURCE:

 [View W6100-Q on WIN SOURCE](#)

 [WIZnet Information](#)

## Optimize Your Supply Chain with WIN SOURCE Solutions

-  Global Sourcing Solution
-  Obsolete Management
-  Cost Control Management
-  Shortage Management
-  Alternative Solution
-  Excess Inventory Management