



**THE DATASHEET OF
TP0310K**



TP0310K – 27dBm (0.5W) CW, 0.1 – 3.8 GHz Power Low Noise Amplifier

1.0 Features

- Small signal gain @ 1850MHz:16.5dB
- OP1dB @ 1850MHz: 27.5dBm
- NF:1.0dB
- OIP3 @1850MHz: 39dBm
- 5V Typical operation
- Operating frequency: 0.1GHz to 3.8GHz

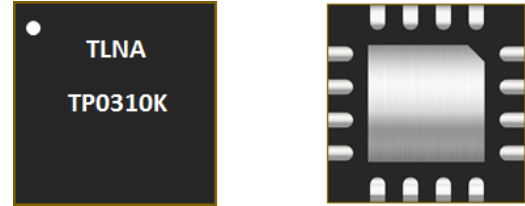

Figure 1.1 Device Image
(16 Pin 3x3x0.8mm QFN Package)

2.0 Applications

- 4G/5G Infrastructure Radios
- Small Cells and Cellular Repeaters
- L, S band Phase Array Radar
- Mil/Comms Radios
- SDARS



**RoHS/REACH/Halogen Free
Compliance**

3.0 Description

The TP0310K is a power Low Noise Amplifier (LNA) providing high gain and linearity. With a simple input and output match, this LNA can be tuned for different frequency bands targeting low noise, high power and high linearity.

The TP0310K is packaged in a compact, low cost Dual Flat No Lead (QFN) 3x3x0.8mm, 16 pin plastic package.

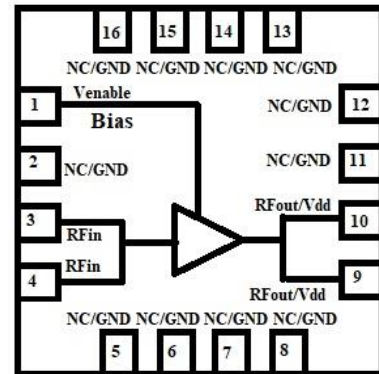

Figure 3.1 Function Block Diagram
(Top View)

4.0 Ordering Information

Table 4.1 Ordering Information

| Base Part Number | Package Type | Form | Qty | Reel Diameter | Reel Width | Orderable Part Number |
|--|---------------------|---------------|------|---------------|------------|-----------------------|
| TP0310K | 16Pin 3x3x0.8mm DFN | Tape and Reel | 3000 | 13" (330mm) | 18mm | TP0310KMTRPBF |
| Tuned Evaluation Board, 1700 - 2000MHz | | | | | | TP0310K-EVB-A |
| Tuned Evaluation Board, 2300 - 2700MHz | | | | | | TP0310K-EVB-B |
| Tuned Evaluation Board, 3300 - 3800MHz | | | | | | TP0310K-EVB-C |

5.0 Pin Description

Table 5.1 Pin Definition

| Pin Number | Pin Name | Description |
|--------------|------------------------------------|---|
| 2,5-8, 11-16 | NC | No internal connection, can be connected to ground |
| 1 | Venable | Venable along with series resistor, sets the Idq. Venable <0.2V disables the device |
| 3,4 | RF _{IN} | RF Input. DC blocking cap required |
| 9,10 | RF _{OUT} /V _{dd} | RF Output. Vdd supplied through an external choke inductor |
| Package Base | Paddle/Slug | DC and RF Ground. Also provides thermal relief. Multiple vias are recommended |

Note: [1] The backside ground slug of the device must be grounded directly to the ground plane through multiple vias to ensure proper operation. Adequate heatsinking required.

6.0 Absolute Maximum Ratings

Table 6.1 Absolute Maximum Ratings @T_A=+25°C Unless Otherwise Specified

| Parameter | Symbol | Value | Unit |
|---|-------------------|--------------|------|
| Electrical Ratings | | | |
| Supply voltage, Venable | V _{dd} | +6 | V |
| Drain current | I _{DQ} | 150 | mA |
| RF input power CW | RF _{IN} | 23 | dBm |
| Storage Temperature Range | T _{st} | -55 to +150 | °C |
| Operating Temperature Range | T _{op} | -40 to +105 | °C |
| Maximum Junction Temperature | T _J | 170 | °C |
| Thermal Ratings | | | |
| Thermal Resistance (junction-to-case) – Bottom side | R _{θJC} | 10 | °C/W |
| Soldering Temperature | T _{SOLD} | 260 | °C |
| ESD Ratings | | | |
| Human Body Model (HBM) | Level 1B | 500 to <1000 | V |
| Charged Device Model (CDM) | Level C | ≥1000 | V |
| Moisture Rating | | | |
| Moisture Sensitivity Level | MSL | 1 | - |

Attention:

Maximum ratings are absolute ratings. Exposure to absolute maximum rating conditions for extended periods may affect device reliability. Exceeding one or a combination of the absolute maximum ratings may cause permanent and irreversible damage to the device and/or to surrounding circuit.

7.0 Recommended DC Operating Conditions

Table 7.1 Recommended Operating Conditions

| Parameter | Symbol | Minimum | Typical | Maximum | Unit |
|-----------------------------|-------------------------------------|---------|---------|---------|------|
| Drain Voltage | V_{DD} | | +5.0 | | V |
| Venable Voltage | V_{enable} | | +5.0 | | V |
| Drain Bias Current | I_{DQ} , Set by external resistor | | 140 | | mA |
| Venable Bias Current | I_{bias} | | 3.5 | 4 | mA |
| Operating Temperature Range | | -40 | +25 | +105 | °C |

8.0 RF Electrical Specifications for 1700 - 2000MHz, 2300 - 2700MHz and 3300 – 3800MHz EVB

Table 8.1 1700 – 2000MHz EVB @ $T_A=+25^\circ\text{C}$ Unless Otherwise Specified; Venable = High

| Parameter | Test Condition | Minimum | Typical | Maximum | Unit |
|---------------------|---|---------|---------|---------|------|
| Gain | Across Band | | 16-17 | | dB |
| Noise Figure | Across Band | | 1.0 | | dB |
| EVB Noise Figure | Across Band | | 1.05 | | dB |
| Input Return Loss | Across Band | | 11-14 | | dB |
| Output Return Loss | Across Band | | 10-13 | | dB |
| OP1dB | Across Band | | 27-27.5 | | dBm |
| OIP3 | Across Band, 8dBm per tone, Tone Spacing 2MHz | | 39 | | dBm |
| Switching Rise Time | 10/90% of the RF value | | 4 | | nsec |
| Switching Fall Time | 10/90% of the RF value | | 1000 | | nsec |

Table 8.2 2300 – 2700MHz EVB @ $T_A=+25^\circ\text{C}$ Unless Otherwise Specified; Venable = High

| Parameter | Test Condition | Minimum | Typical | Maximum | Unit |
|---------------------|---|---------|---------|---------|------|
| Gain | 2500MHz | 13 | 14 | | dB |
| Noise Figure | 2500MHz | | 1.1 | | dB |
| EVB Noise Figure | 2500MHz | | 1.2 | | dB |
| Input Return Loss | 2500MHz | | 16 | | dB |
| Output Return Loss | 2500MHz | | 18 | | dB |
| OP1dB | 2500MHz | 25.5 | 27 | | dBm |
| OIP3 | 2500MHz, 8dBm per tone, Tone Spacing 2MHz | 35 | 37 | | dBm |
| Switching Rise Time | 10/90% of the RF value | | 4 | | nsec |
| Switching Fall Time | 10/90% of the RF value | | 1000 | | nsec |

Table 8.3 3300 – 3800MHz EVB @ $T_A=+25^{\circ}C$ Unless Otherwise Specified; Venable = High

| Parameter | Test Condition | Minimum | Typical | Maximum | Unit |
|---------------------|--|---------|-----------|---------|------|
| Gain | Across Band | | 11-11.5 | | dB |
| Noise Figure | Across Band | | 0.85-1.15 | | dB |
| EVB Noise Figure | Across Band | | 1-1.3 | | dB |
| Input Return Loss | Across Band | | 7-11 | | dB |
| Output Return Loss | Across Band | | 17-24 | | dB |
| OP1dB | Across Band | | 27.5 | | dBm |
| OIP3 | Across Band, 8dBm per tone, Tone Spacing 2MHz | | 41-42 | | dBm |
| Switching Rise Time | 10/90% of the RF value | | 4 | | nsec |
| Switching Fall Time | 10/90% of the RF value | | 1000 | | nsec |

9.0 Typical Characteristics

9.1 2300 - 2700MHz tuned EVB ($V_{DD}=5V$, $I_{DQ}=140mA$), $-40^{\circ}C$, $25^{\circ}C$, $85^{\circ}C$, $105^{\circ}C$, Narrowband

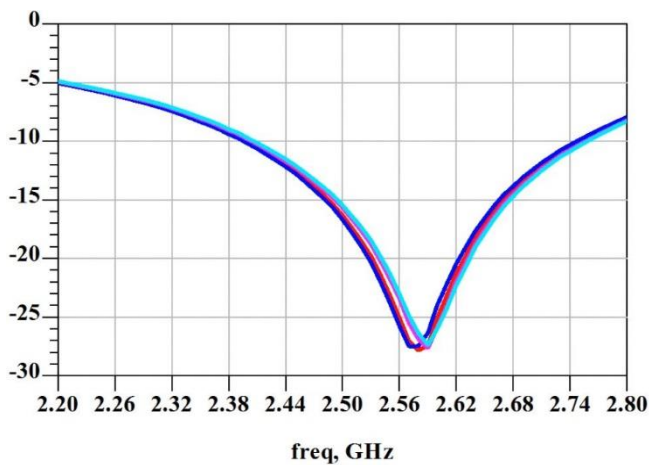

Figure 9.1 S11 (IRL) vs Freq

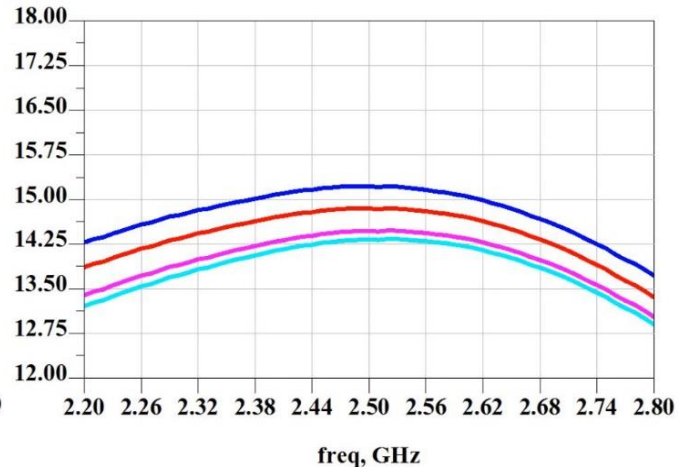

Figure 9.2 S21 (Gain) vs Freq

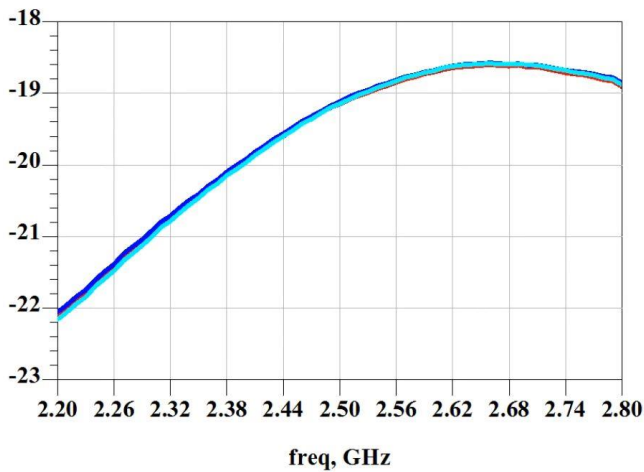

Figure 9.3 S12 (Rev Iso) vs Freq

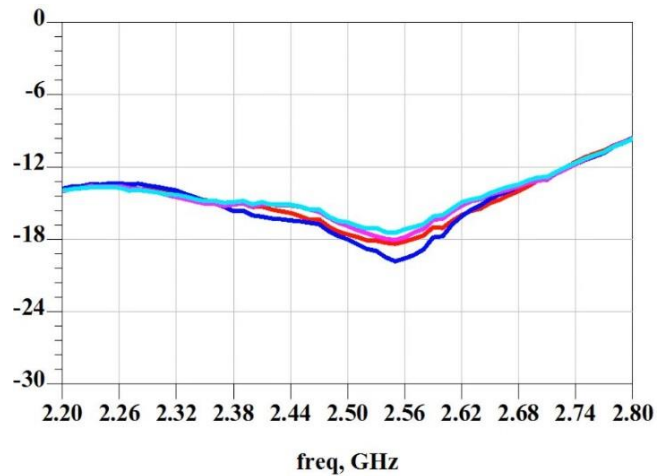

Figure 9.4 S22 (ORL) vs Freq

9.2 2300 - 2700MHz tuned EVB (Vdd=5V, I_{DQ}=140mA), -40°C, 25°C, 85°C, 105°C, Broadband

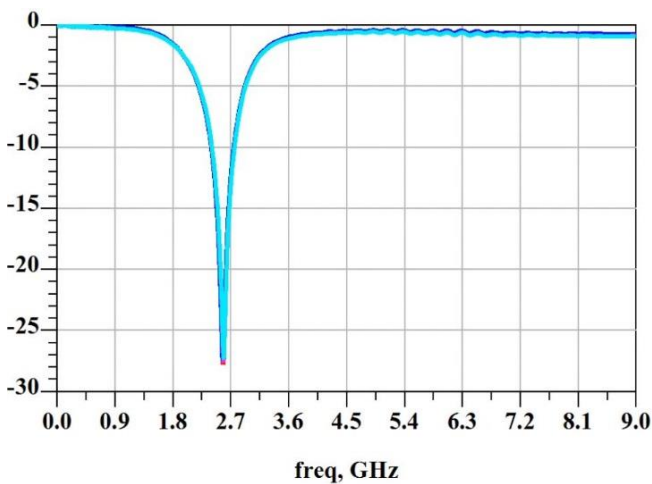

Figure 9.5 S11 (IRL) vs Freq

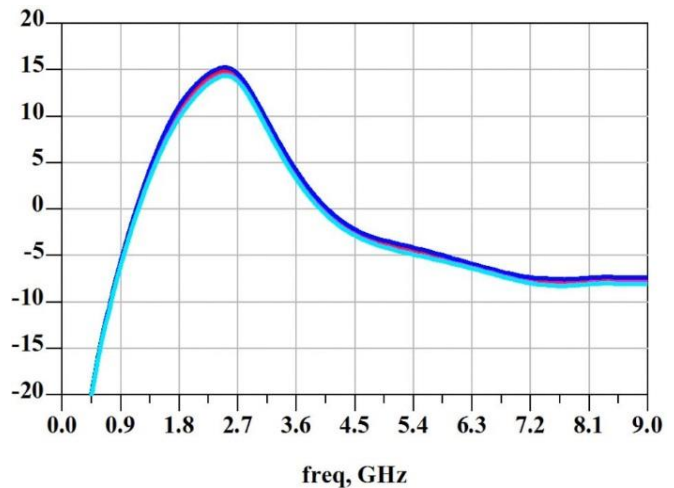

Figure 9.6 S21 (Gain) vs Freq

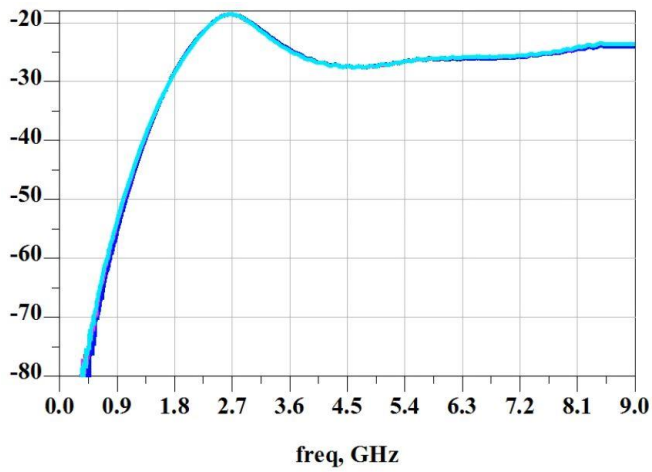

Figure 9.7 S12 (Rev Iso) vs Freq

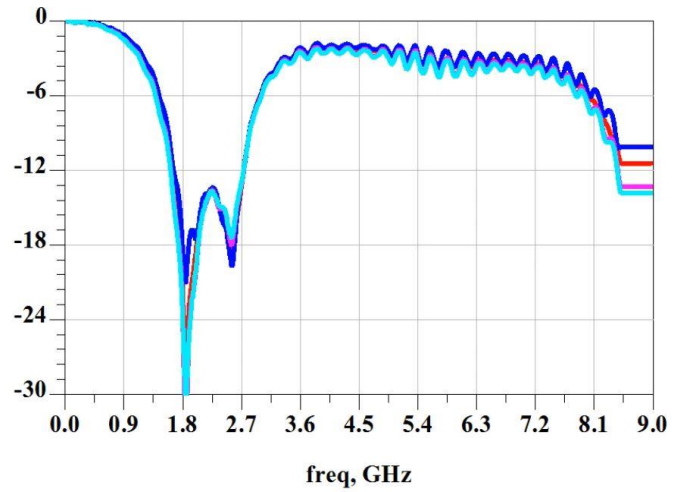

Figure 9.8 S22 (ORL) vs Freq

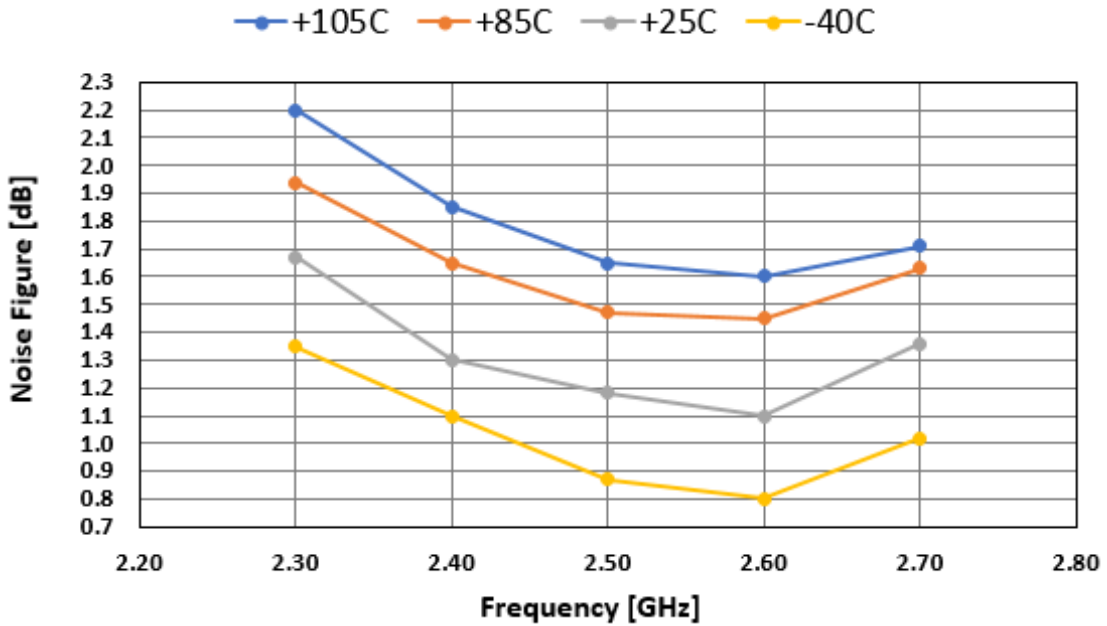

Figure 9.9 Noise Figure (EVB) vs Freq

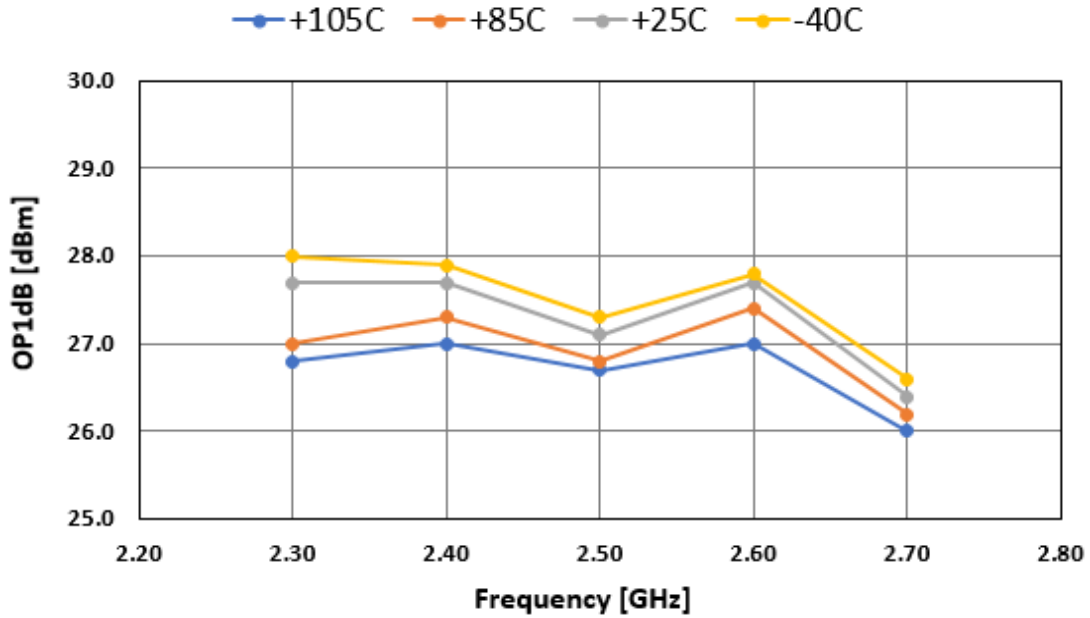

Figure 9.10 Output P1dB vs Freq

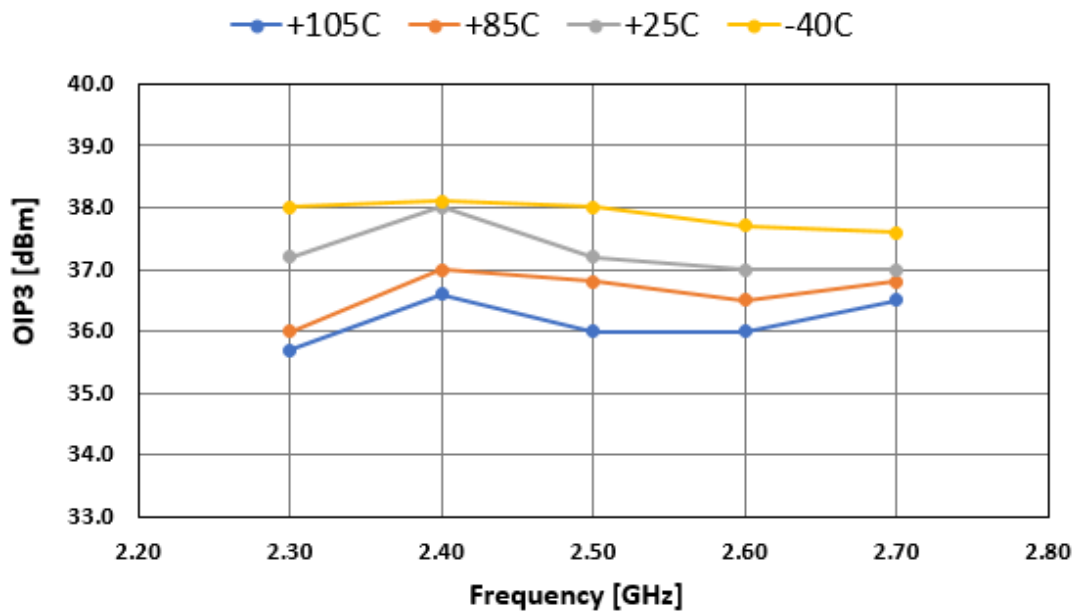

Figure 9.11 Output IP3 vs Freq

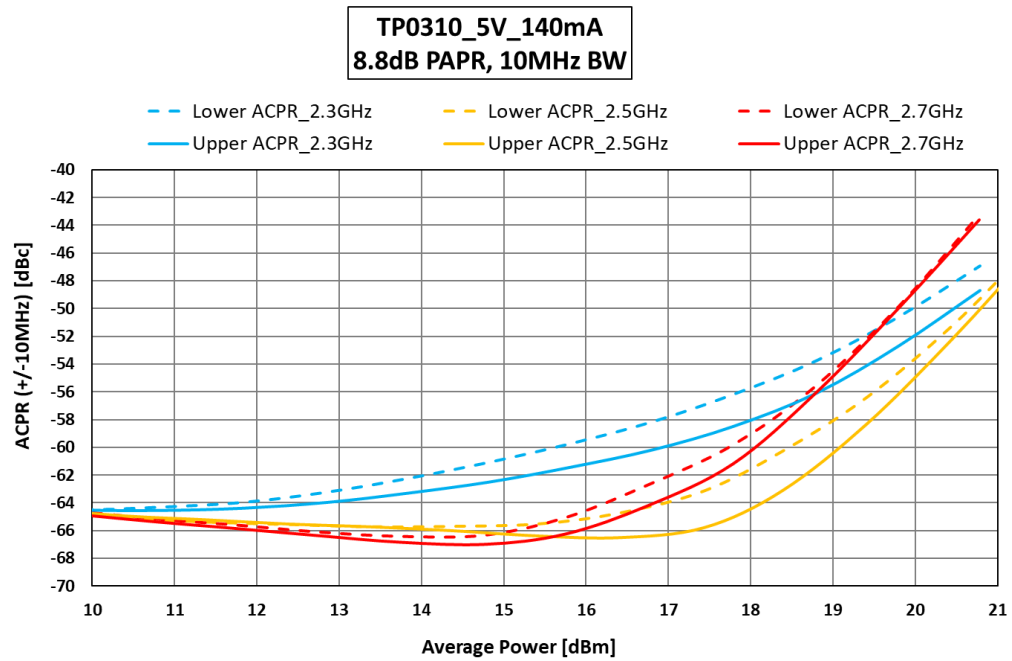

Figure 9.12 ACPR vs Average Power

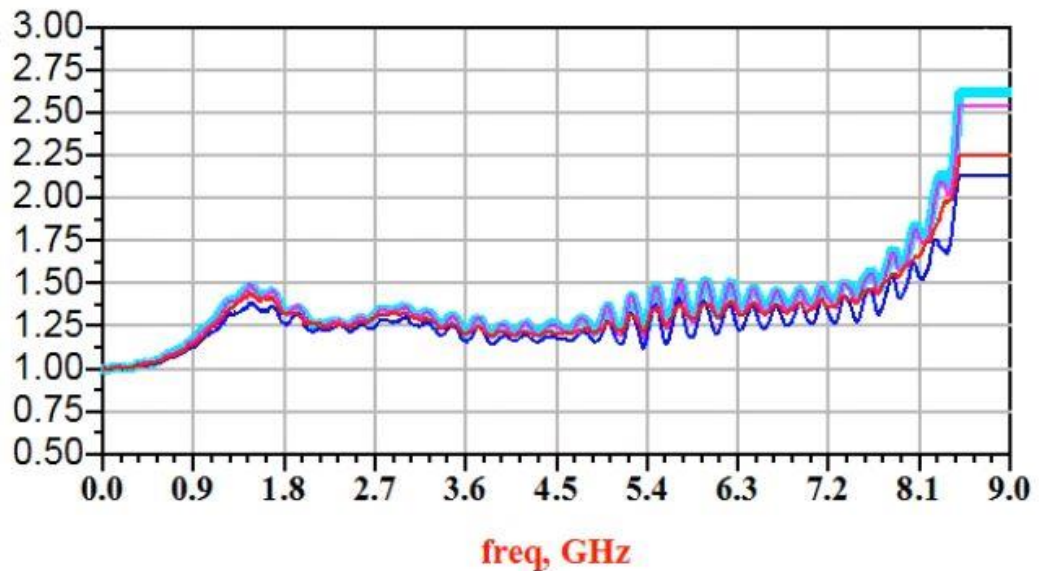

Figure 9.13 Mu1 vs Freq

10.0 Evaluation Boards

10.1 1700 - 2000MHz EVB

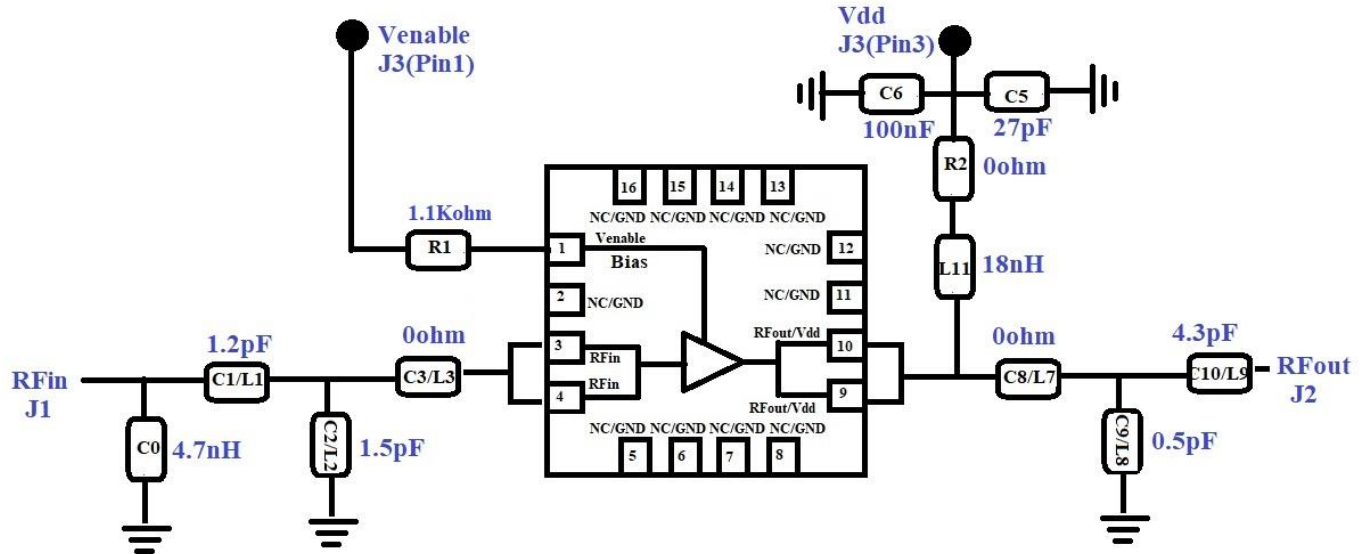

Figure 10.1 Schematic of the 1700 - 2000MHz EVB

Table 10.1 BOM of the 1700 - 2000MHz EVB

| Component ID | Value | Manufacturer | Recommended Part Number |
|--------------|--------------------------------------|--------------|-------------------------|
| C0 | 4.7nH | Coilcraft | 0402HP-4N7XE |
| C1 | 1.2pF | Murata | GJM1555C1H1R2BB01 |
| C2 | 1.5pF | Murata | GJM1555C1H1R5BB01 |
| R1 | 1.1K | Panasonic | ERJ-2RKF1101X |
| C9 | 0.5pF | Murata | GJM1555C1HR50BB01 |
| C10/L9 | 4.3pF | Murata | GJM1555C1H4R3BB01 |
| C3/L3 | 0 ohm | Panasonic | ERJ-2GE0R00X |
| C8/L7 | 0 ohm | Panasonic | ERJ-2GE0R00X |
| R2 | 0 ohm | Panasonic | ERJ-2GE0R00X |
| L11 | 18nH | Coilcraft | 0402HP-18NXE |
| C5 | 100nF | TDK | C1005X7R1H104K050BE |
| C6 | 27pF | AVX | 04025A270JAT4A |
| PCB | Rogers RO4350B, 20 mils, 1 oz copper | | |

10.2 2300 - 2700MHz EVB

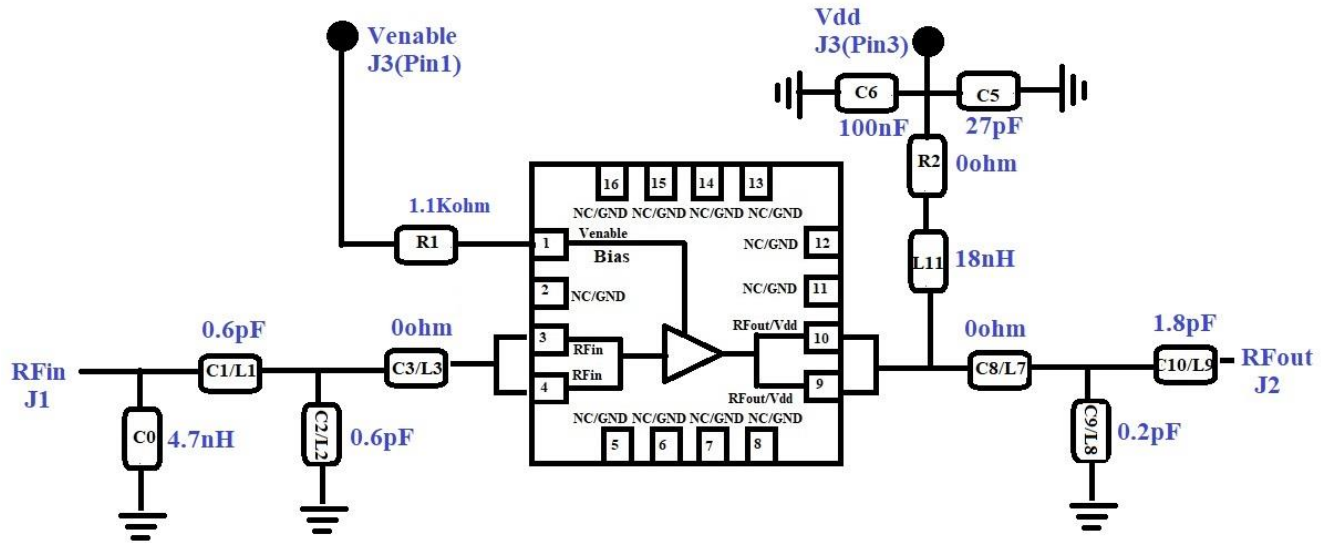

Figure 10.2 Schematic of the 2300 - 2700MHz EVB

Table 10.2 BOM for 2300 - 2700MHz EVB

| Component ID | Value | Manufacturer | Recommended Part Number |
|--------------|--------------------------------------|--------------|-------------------------|
| C0 | 4.7nH | Coilcraft | 0402HP-4N7XE |
| C1 | 0.6pF | Murata | GJM1555C1HR60BB01 |
| C2 | 0.6pF | Murata | GJM1555C1HR60BB01 |
| C3/L3 | 0 ohm | Panasonic | ERJ-2GE0R00X |
| R2 | 0 ohm | Panasonic | ERJ-2GE0R00X |
| C8/L7 | 0 ohm | Panasonic | ERJ-2GE0R00X |
| R1 | 1.1K | Panasonic | ERJ-2RKF1101X |
| C9 | 0.2pF | Murata | GJM1555C1HR20BB01 |
| C10/L9 | 1.8pF | Murata | GJM1555C1H1R8BB01 |
| L11 | 18nH | Coilcraft | 0402HP-18NXE |
| C5 | 100nF | ATC | 600S1R0CT250XT |
| C6 | 27pF | AVX | 04025A270JAT4A |
| PCB | Rogers RO4350B, 20 mils, 1 oz copper | | |

10.3 3300 - 3800MHz EVB

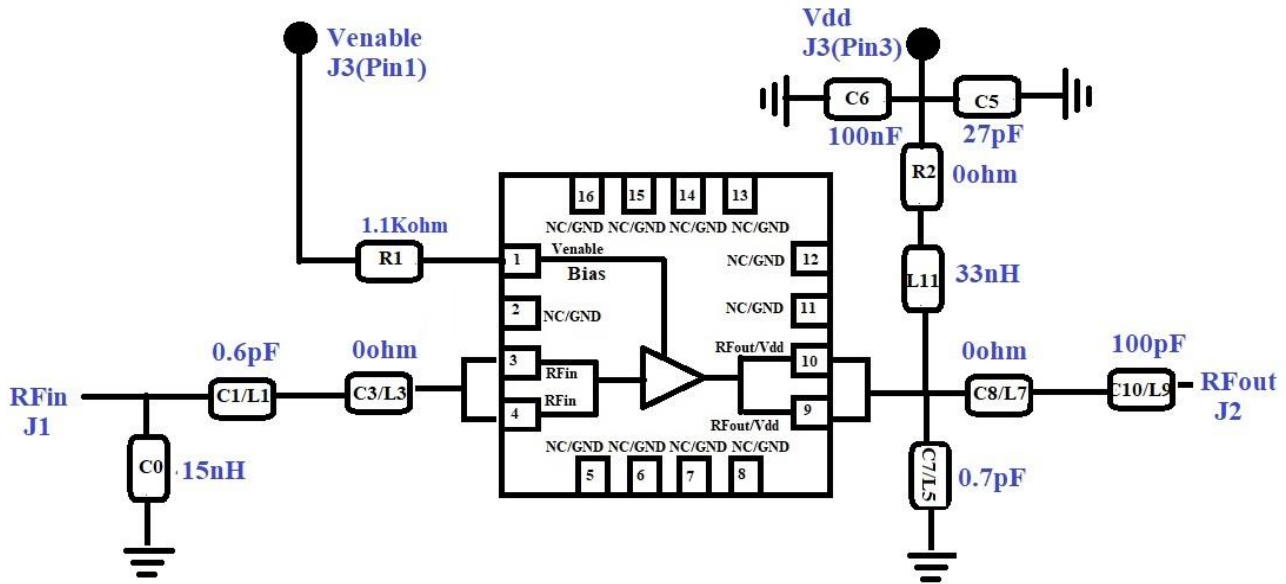

Figure 10.3 Schematic of the 3300 - 3800MHz EVB

Table 10.3 BOM of the 3300 - 3800MHz EVB

| Component ID | Value | Manufacturer | Recommended Part Number |
|--------------|--------------------------------------|--------------|-------------------------|
| C0 | 15nH | Coilcraft | 0402HP-15NXE |
| C1 | 0.6pF | Murata | GJM1555C1HR60BB01 |
| C3/L3 | 0 ohm | Panasonic | ERJ-2GE0R00X |
| R1 | 1.1K | Panasonic | ERJ-2RKF1101X |
| C7 | 0.7pF | Murata | GJM1555C1HR70BB01 |
| C8/L7 | 0 ohm | Panasonic | ERJ-2GE0R00X |
| C10/L9 | 100pF | AVX | 04025A101JAT4A |
| R2 | 0 ohm | Panasonic | ERJ-2GE0R00X |
| L11 | 33nH | Coilcraft | 0402HP-33NXE |
| C5 | 100nF | ATC | 600S1R0CT250XT |
| C6 | 27pF | AVX | 04025A270JAT4A |
| PCB | Rogers RO4350B, 20 mils, 1 oz copper | | |

11.0 Device Package Information

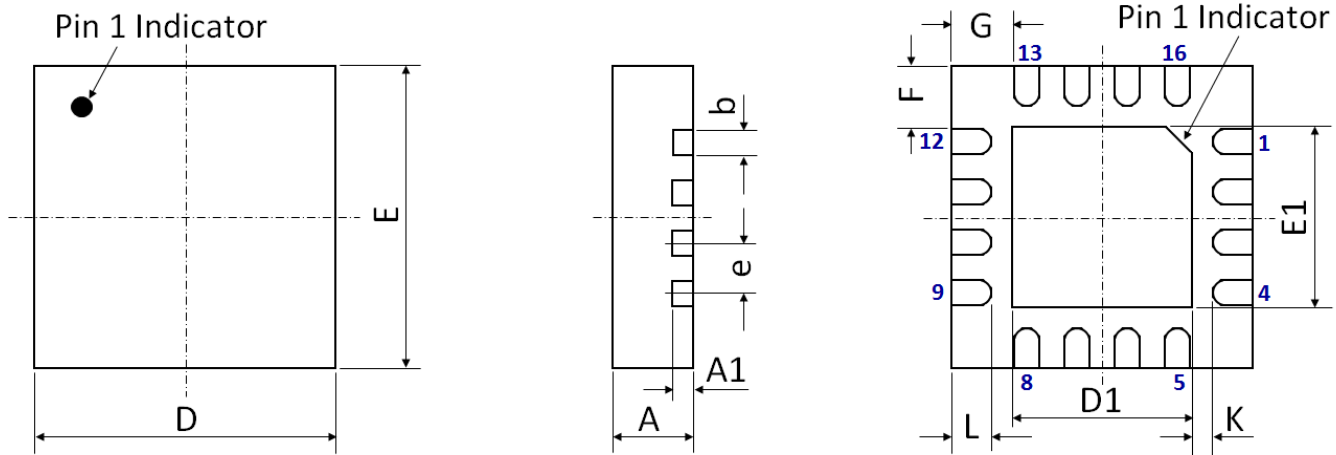

Figure 11.1 Device Package Drawing
(All dimensions are in mm)

Table 11.1 Device Package Dimensions

| Dimension (mm) | Value (mm) | Tolerance (mm) | Dimension (mm) | Value (mm) | Tolerance (mm) |
|----------------|------------|----------------|----------------|------------|----------------|
| A | 0.80 | ±0.05 | E | 3.00 BSC | ±0.05 |
| A1 | 0.203 | ±0.02 | E1 | 1.70 | ±0.05 |
| b | 0.25 | +0.05/-0.07 | F | 0.625 | ±0.05 |
| D | 3.00 BSC | ±0.05 | G | 0.625 | ±0.05 |
| D1 | 1.70 | ±0.05 | L | 0.25 | ±0.05 |
| e | 0.50 BSC | ±0.05 | K | 0.40 | ±0.05 |

Note: Lead finish: Pure Sn without underlayer; Thickness: 7.5µm ~ 20µm (Typical 10µm ~ 12µm)

Attention:

Please refer to application notes [TN-001](#) and [TN-002](#) at <http://www.tagoretech.com> for PCB and soldering related guidelines.

12.0 PCB Land Design

Guidelines:

- [1] 2-layer PCB is recommended
- [2] Via diameter is recommended to be 0.3mm to prevent solder wicking inside the vias
- [3] Thermal vias shall only be placed on the center pad and should be filled/plugged with solder or copper
- [4] The maximum via number for the center pad is $3(X) \times 3(Y) = 9$

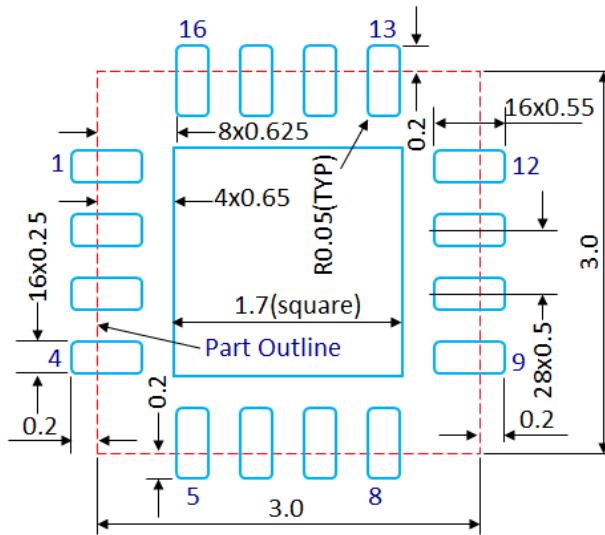

Figure 12.1 PCB Land Pattern
(Dimensions are in mm)

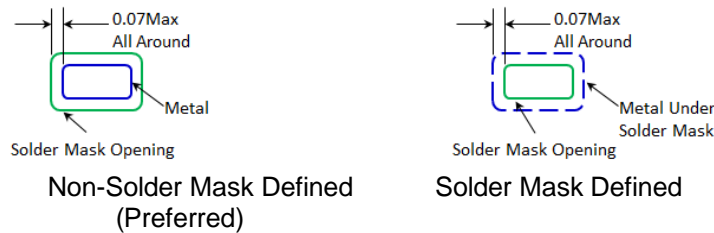

Figure 12.2 Solder Mask Pattern
(Dimensions are in mm)

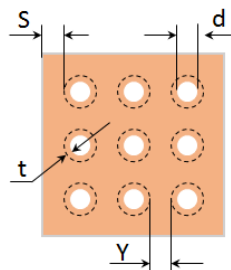

Figure 12.3 Thermal Via Pattern
(Recommended Values: $S \geq 0.15\text{mm}$; $Y \geq 0.20\text{mm}$; $d = 0.3\text{mm}$; Plating Thickness $t = 25\mu\text{m}$ or $50\mu\text{m}$)

13.0 PCB Stencil Design

Guidelines:

[1] Laser-cut, stainless steel stencil is recommended with electro-polished trapezoidal walls to improve the paste release.

[2] Stencil thickness is recommended to be 125µm.

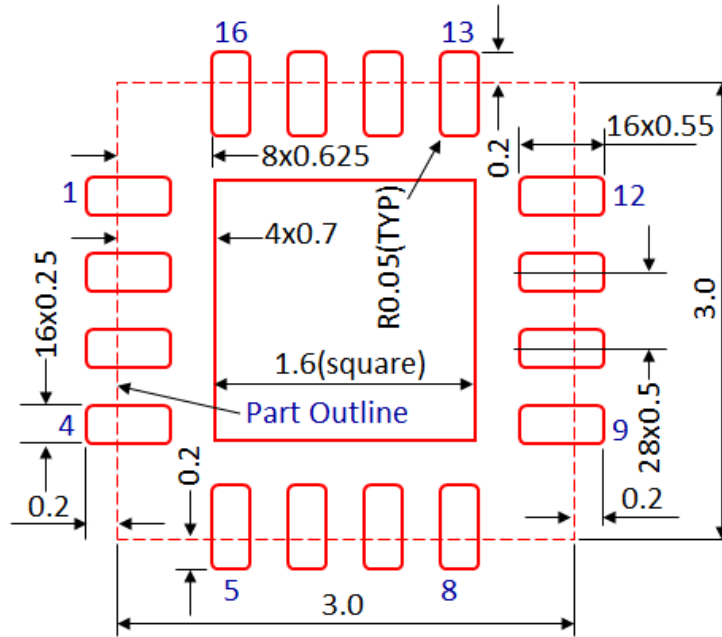

Figure 13.1 Stencil Openings
(Dimensions are in mm)

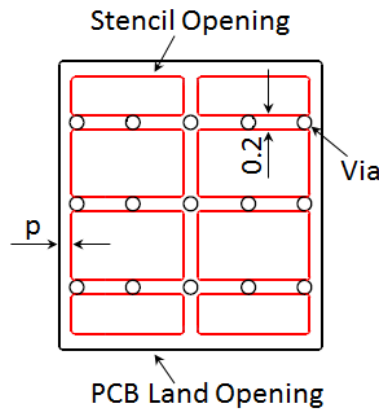

Figure 13.2 Stencil Openings Shall not Cover Via Areas If Possible
(Dimensions are in mm)

14.0 Tape and Reel Information

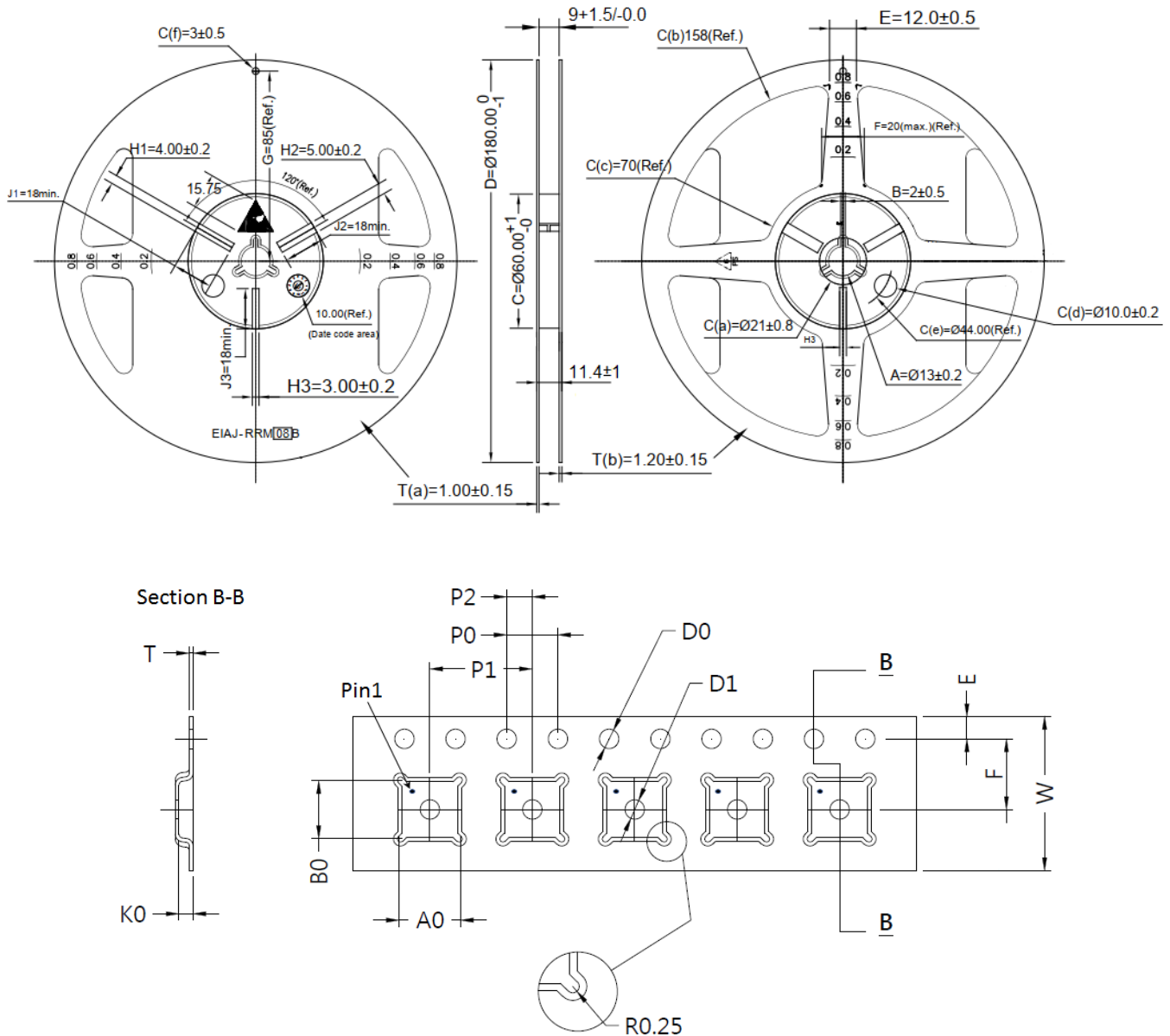

Figure 14.1 Tape and Reel Drawing

Table 14.1 Tape and Reel Dimensions

| Dimension (mm) | Value (mm) | Tolerance (mm) | Dimension (mm) | Value (mm) | Tolerance (mm) |
|----------------|------------|----------------|----------------|------------|----------------|
| A0 | 3.35 | ±0.10 | K0 | 1.10 | ±0.10 |
| B0 | 3.35 | ±0.10 | P0 | 4.00 | ±0.10 |
| D0 | 1.50 | +0.10/-0.00 | P1 | 8.00 | ±0.10 |
| D1 | 1.50 | +0.10/-0.00 | P2 | 2.00 | ±0.05 |
| E | 1.75 | ±0.10 | T | 0.30 | ±0.05 |
| F | 5.50 | ±0.05 | W | 12.00 | ±0.30 |

Edition Revision 1.3 - 2021-04-19

Published by

Tagore Technology Inc.
5 East College Drive, Suite 200
Arlington Heights, IL 60004, USA

©2020 All Rights Reserved

Legal Disclaimer

The information provided in this document shall in no event be regarded as a guarantee of conditions or characteristics. Tagore Technology assumes no responsibility for the consequences of the use of this information, nor for any infringement of patents or of other rights of third parties which may result from the use of this information. No license is granted by implication or otherwise under any patent or patent rights of Tagore Technology. The specifications mentioned in this document are subject to change without notice.

Information

For further information on technology, delivery terms and conditions and prices, please contact Tagore Technology: support@tagoretech.com.

Looking for pricing, stock, or lifecycle information?

Click below to explore more details on WIN SOURCE:

 [View TP0310K on WIN SOURCE](#)

 [TagoreTech Information](#)

Optimize Your Supply Chain with WIN SOURCE Solutions

-  Global Sourcing Solution
-  Obsolete Management
-  Cost Control Management
-  Shortage Management
-  Alternative Solution
-  Excess Inventory Management