

TL0374J: 0.03 – 3.0 GHz GaAs Ultra Low Noise Amplifier

1.0 Features

- Small signal gain @ 1800 MHz: 21.5 dB
- NF @ 1800 MHz: 0.35 dB
- OP1dB @ 1800 MHz: 18.5 dBm
- OIP3dB @ 1800 MHz: 35 dBm
- 5 V Typical operating voltage
- Operating frequency: 0.03 to 3.0 GHz



Figure 1.1 Device Image
 (8 Pin 2 × 2 × 0.75 mm DFN Package)

2.0 Applications

- 4G/5G Infrastructure Radios
- Small Cells and Cellular Repeaters
- Phase Array Radar
- SDARS



RoHS/REACH/Halogen Free Compliance

3.0 Description

The TL0374J is a broadband, ultra-low Noise Amplifier (LNA) providing high gain and linearity. With a simple input and output match, this LNA can be tuned for different frequency bands targeting LTE (small cells and infrastructure) and any other applications requiring low noise, high gain, and linearity. For >3 GHz frequency band, TL0375J can be considered.

The TL0374J is packaged in a compact, low-cost Dual Flat No Lead (DFN) 2 x 2 x 0.75 mm, 8 pin plastic package.

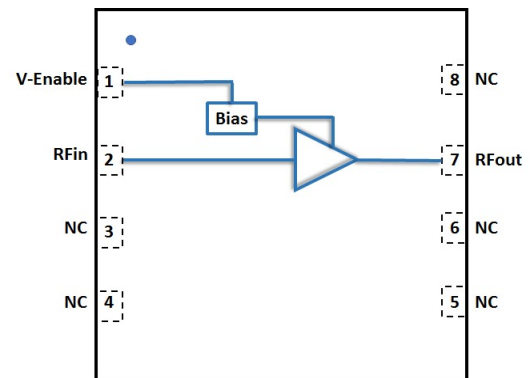

Figure 3.1 Function Block Diagram
 (Top View)

4.0 Ordering Information

Table 4.1 Ordering Information

Base Part Number	Package Type	Form	Qty	Reel Diameter	Reel Width	Orderable Part Number
TL0374J	8 Pin 2×2× 0.75 mm DFN	Tape & Reel	5000	13" (330 mm)	18 mm	TL0374JMTRPBF
	Tuned Evaluation Board, 1800 – 2100 MHz					TL0374J-EVB-A
	Tuned Evaluation Board, 2500 – 2700 MHz					TL0374J-EVB-B
	Tuned Evaluation Board, 30 – 1000 MHz					TL0374J-EVB-C
	Tuned Evaluation Board, 30-2600 MHz [3.3 V 30 mA]					TL0374J-EVB-D1
	Tuned Evaluation Board, 30-2600 MHz [5 V 55 mA]					TL0374J-EVB-D2
	Tuned Evaluation Board, 1000-2000 MHz					TL0374J-EVB-E

5.0 Pin Description

Table 5.1 Pin Definition

Pin Number	Pin Name	Description
3-6, 8	NC	No internal connection, can be connected to ground
1	Venable	Venable along with series resistor, sets the Idq. Venable <0.2 V disables the device
2	RF _{IN}	RF Input. DC blocking cap required
7	RF _{OUT} /V _{dd}	RF Output. V _{dd} supplied through an external choke inductor
Package Base	Paddle/Slug	DC and RF Ground. Also provides thermal relief. Multiple vias are recommended

Note: [1] The backside ground slug of the device must be grounded directly to the ground plane through multiple vias to ensure proper operation. Adequate heat sinking required.

6.0 Absolute Maximum Rating

Table 6.1 Absolute Maximum Rating @T_A=+25°C Unless Otherwise Specified

Parameter	Symbol	Value	Unit
Electrical Ratings			
Supply voltage, Venable	V _{dd}	+6	V
Drain current	I _{DQ}	70	mA
RF input power CW	RF _{IN}	23	dBm
Storage Temperature Range	T _{st}	-55 to +150	°C
Operating Temperature Range	T _{op}	-40 to +105	°C
Maximum Junction Temperature	T _J	170	°C
Thermal Ratings			
Thermal Resistance (junction-to-case) – Bottom side	R _{θJC}	15.0	°C/W
Soldering Temperature	T _{SOLD}	260	°C
ESD Ratings			
Human Body Model (HBM)	Level 1B	500 to <1000	V
Charged Device Model (CDM)	Level C	≥1000	V
Moisture Rating			
Moisture Sensitivity Level	MSL	1	-

Attention:

Maximum ratings are absolute ratings. Exposure to absolute maximum rating conditions for extended periods may affect device reliability. Exceeding one or a combination of the absolute maximum ratings may cause permanent and irreversible damage to the device and/or to surrounding circuit.

7.0 Recommended DC Operating Conditions

Table 7.1 Recommended Operating Conditions

Parameter	Symbol	Minimum	Typical	Maximum	Unit
Drain Voltage	V_{DD}		+5.0		V
Venable Voltage	V_{enable}		+5.0		V
Drain Bias Current	I_{DQ} , Set by external resistor	45	60		mA
Venable Bias Current	I_{bias}		3.0		mA
Operating Temperature Range		-40	+25	+105	°C

8.0 Switching Time

Table 8.1 Switching time.

Parameter	Test Condition	Typical	Unit
Switching Rise Time	10/90% of the RF value	300	nsec
Switching Fall Time	10/90% of the RF value	350	nsec

9.0 RF Electrical Specifications

Table 9.1 EVB A 1800-2100 MHz
 $V_{enable}=5\text{ V}$, $I_{dd}=60\text{ mA}$, $V_{dd}=5\text{ V}$, @ $T_A=+25^\circ\text{C}$ Unless Otherwise Specified

Parameter	Test Condition	Minimum	Typical	Maximum	Unit
Gain	Across the band		20-22		dB
Noise Figure	Across the band		0.3-0.4		dB
EVB Noise Figure	Across the band		0.4-0.5		dB
Input Return Loss	Across the band		17-27		dB
Output Return Loss	Across the band		9-10		dB
OP1dB	Across the band		18.3-19.5		dBm
OIP3	Across the band, 0 dBm per tone, Tone Spacing 1 MHz		35-37.3		dBm

Table 9.2 EVB B 2500-2700 MHz
 $V_{enable}=5\text{ V}$, $I_{dd}=60\text{ mA}$, $V_{dd}=5\text{ V}$, @ $T_A=+25^\circ\text{C}$ Unless Otherwise Specified

Parameter	Test Condition	Minimum	Typical	Maximum	Unit
Gain	Across Band		18.5-19.2		dB
Noise Figure	Across Band		0.3-0.4		dB
EVB Noise Figure	Across Band		0.4-0.5		dB
Input Return Loss	Across Band		27-33		dB
Output Return Loss	Across Band		9-9.3		dB
OP1dB	Across Band		18.4-19.6		dBm
OIP3	Across Band, 0 dBm per tone, Tone Spacing 1 MHz		41-43		dBm

Table 9.3 EVB C 30-1000 MHz

Venable= 3.3 V, Idd=30 mA, Vdd=3.3 V, @TA=+25°C Unless Otherwise Specified

Parameter	Test Condition	Minimum	Typical	Maximum	Unit
Gain	Across the band		21.3-25.6		dB
Noise Figure	Across the band		0.5-0.6		dB
EVB Noise Figure	Across the band		0.5-0.7		dB
Input Return Loss	Across the band		12.5-26		dB
Output Return Loss	Across the band		7.4-19.3		dB
OP1dB	Across the band		14.6-15.2		dBm
OIP3	Across the band, 0 dBm per tone, Tone Spacing 1 MHz		27.5-29.3		dBm

Table 9.4 EVB D1 30-2600 MHz

Venable= 3.3 V, Idd=30 mA, Vdd=3.3 V, @TA=+25°C Unless Otherwise Specified

Parameter	Test Condition	Minimum	Typical	Maximum	Unit
Gain	Across the band		13-20.3		dB
Noise Figure	Across the band		0.4-0.6		dB
EVB Noise Figure	Across the band		0.4-0.7		dB
Input Return Loss	Across the band		8.3-16.0		dB
Output Return Loss	Across the band		7.4-19.3		dB
OP1dB	Across the band		12.1-14.7		dBm
OIP3	Across the band, 0 dBm per tone, Tone Spacing 1 MHz		22.6-29.1		dBm

Table 9.5 EVB D2 30-2600 MHz

Venable= 5 V, Idd=55 mA, Vdd=5V, @TA=+25°C Unless Otherwise Specified

Parameter	Test Condition	Minimum	Typical	Maximum	Unit
Gain	Across the band		13.5-21.9		dB
Noise Figure	Across the band		0.5-0.7		dB
EVB Noise Figure	Across the band		0.5-0.8		dB
Input Return Loss	Across the band		8.9-23.5		dB
Output Return Loss	Across the band		6.4-19.6		dB
OP1dB	Across the band		13.8-17.8		dBm
OIP3	Across the band, 0 dBm per tone, Tone Spacing 1 MHz		27.2-33.0		dBm

Table 9.6 EVB E 1000-2000 MHz

Venable= 3.3 V, Idd=50 mA, Vdd=3.3 V, @TA=+25°C Unless Otherwise Specified

Parameter	Test Condition	Minimum	Typical	Maximum	Unit
Gain	Across the band		18.5-23.6		dB
Noise Figure	Across the band		0.4-0.5		dB
EVB Noise Figure	Across the band		0.5-0.6		dB
Input Return Loss	Across the band		5.1-21.5		dB
Output Return Loss	Across the band		5.2-6.7		dB
OP1dB	Across the band		15.8-16.8		dBm
OIP3	Across the band, 0 dBm/ tone, Tone Spacing 1 MHz		30.7-33.4		dBm

10.0 Evaluation Board Details

10.1 EVB A 1.8-2.1 GHz

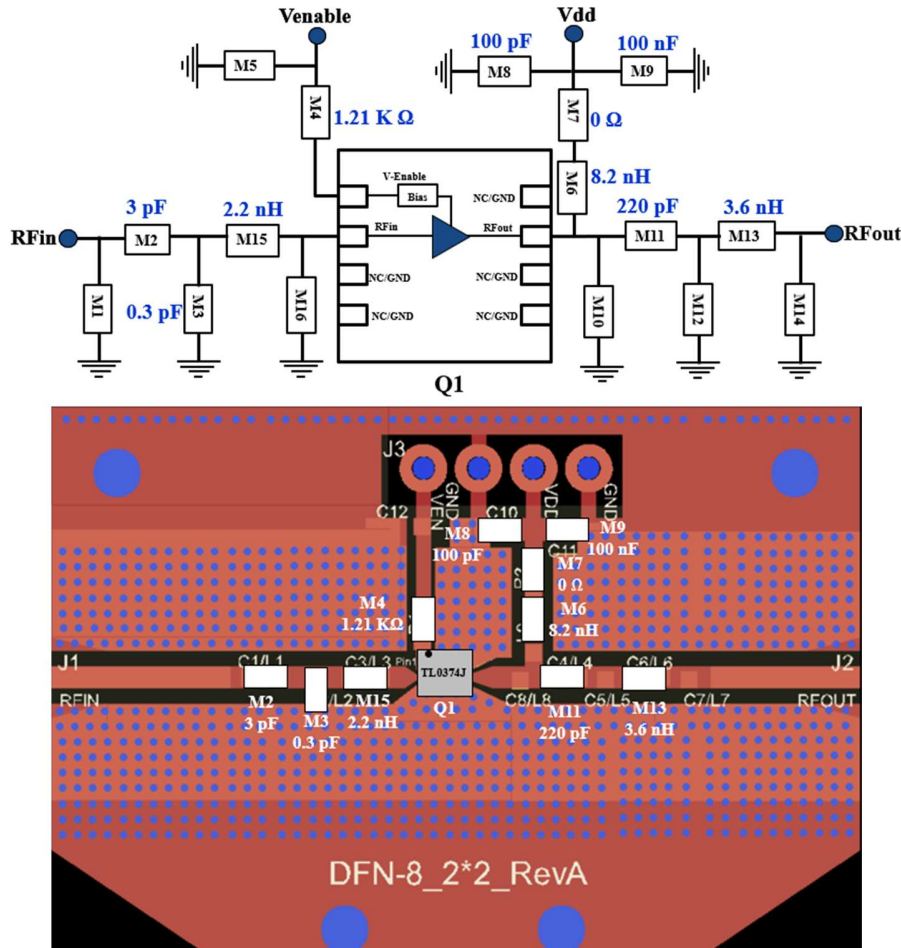

Figure 10.1 Schematic and EVB layout of the 1800-2100MHz EVB-A

Table 10.1 BOM of the 1800-2100MHz EVB A

Component ID	Value	Manufacturer	Recommended Part Number
M2	3.0 pF	Murata	GJM1555C1H3R0BB01
M3	0.3 pF	Murata	GJM1555C1HR30BB01
M15	2.2 nH	Coil craft /Würth Elektronik	0402HP-2N2XJE /744765022A
M4	1.21 KΩ	Panasonic	ERJ-2RKF1211X
M8	100 pF	AVX	04025A101JAT4A
M9	100 nF	TDK	C1005X7R1H104K050BE
M7	0 Ω	Panasonic	ERJ-2GE0R00X
M6	8.2 nH	Coil craft /Würth Elektronik	0402HP-8N2XGE /744765082GA
M11	220 pF	Kemet	C0402C221K5GACAUTO
M13	3.6 nH	Coil Craft /Würth Elektronik	0402HP-3N6XGE /744765036A
Q1	GaAs LNA	Tagore Tech	TL0374J
PCB		Rogers RO4350B, 20 mils, 1 oz copper	

10.2 EVB B 2.5-2.7 GHz

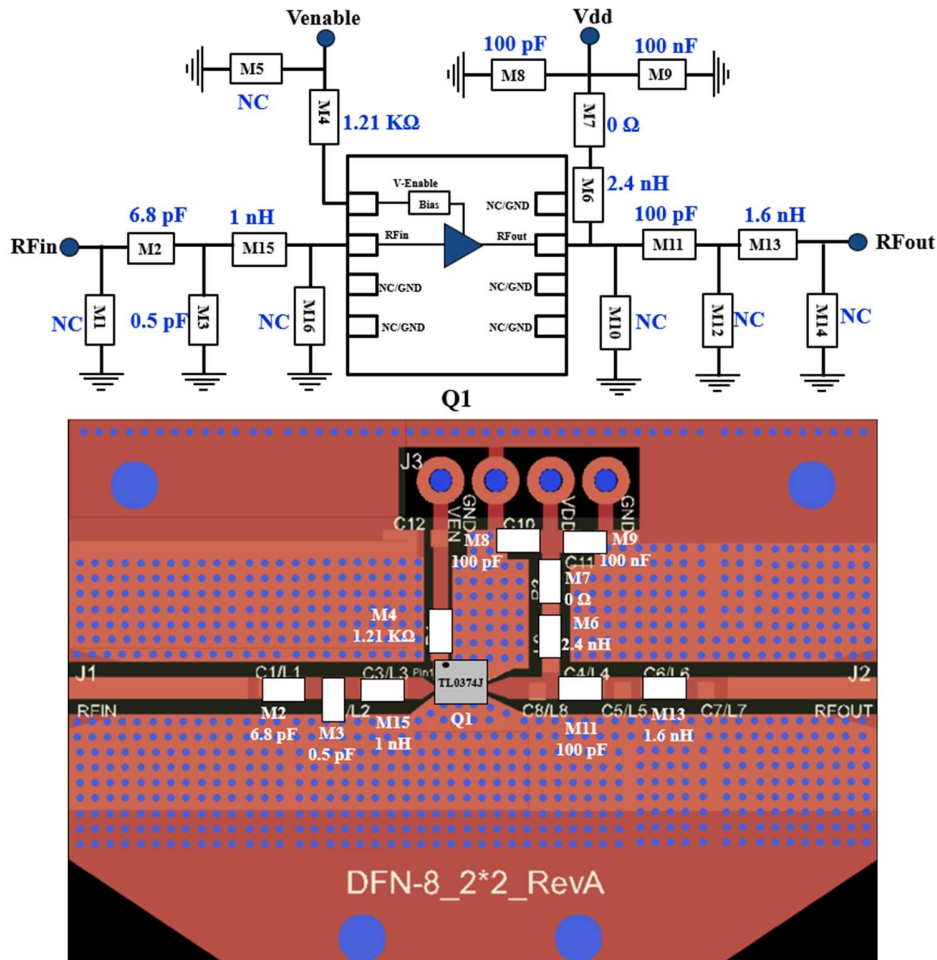

Figure 10.2 Schematic and EVB layout of the 2500-2700 MHz EVB-B

Table 10.2 BOM of the 2500-2700 MHz EVB B

Component ID	Value	Manufacturer	Recommended Part Number
M2	6.8 pF	Murata	GJM1555C1H6R8BB01
M3	0.5 pF	Murata	GJM1555C1HR50BB01
M15	1 nH	Coil craft	0402HP-1N0XJE
M4	1.21 KΩ	Panasonic	ERJ-2RKF1211X
M8	100 pF	AVX	04025A101JAT4A
M9	100 nF	TDK	C1005X7R1H104K050BE
M7	0 Ω	Panasonic	ERJ-2GE0R00X
M6	2.4 nH	Coil craft	0402HP-2N4XGE
M11	100 pF	AVX	04025A101JAT4A
M13	1.6 nH	Coil craft	0603HC-1N6XGLW
Q1	GaAs LNA	Tagore Tech	TL0374J
PCB		Rogers RO4350B, 20 mils, 1 oz copper	

10.3 EVB C 30-1000 MHz

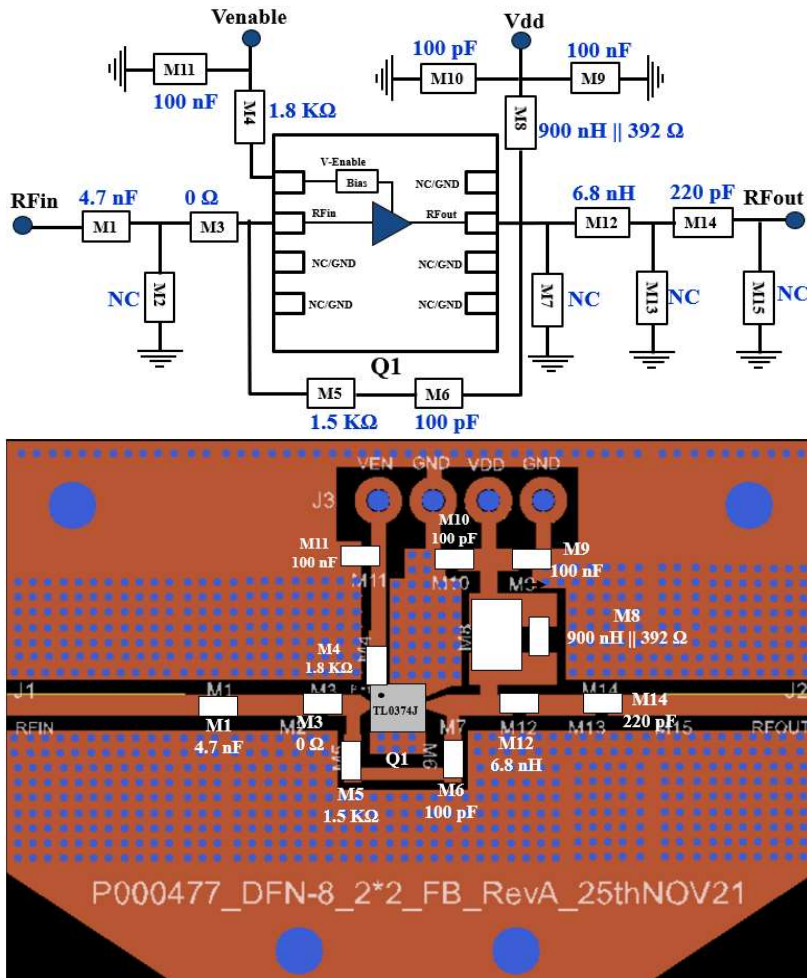

Figure 10.3 Schematic and EVB layout of the 30-1000 MHz EVB-C

Table 10.3 BOM of the 30-1000 MHz EVB C

Component ID	Value	Manufacturer	Recommended Part Number
M1	4.7 nF, 50 V	Murata	GRM1885C1H472JA01D
M3	0 Ω	Panasonic	ERJ-2GE0R00X
M4	1.8 KΩ	Panasonic	ERJ-2RKF1801X
M5	1.5 KΩ	Panasonic	ERJ-2RKF1501X
M6, M10	100 pF	AVX	04025A101JAT4A
M8	900 nH	Coil craft	1008AF-901XJLC
M8	392 Ω	Panasonic	ERJ-UP3F3920V
M9, M11	100 nF	TDK	C1005X7R1H104K050BE
M12	6.8 nH	Coil craft	0402HP-6N8XJRW
M14	220 pF	Kemet	C0402C221K5GACAUTO
Q1	GaAs LNA	Tagore Tech	TL0374J
PCB	Rogers RO4350B, 20 mils, 1 oz copper		

10.4 EVB D1 30-2600 MHz

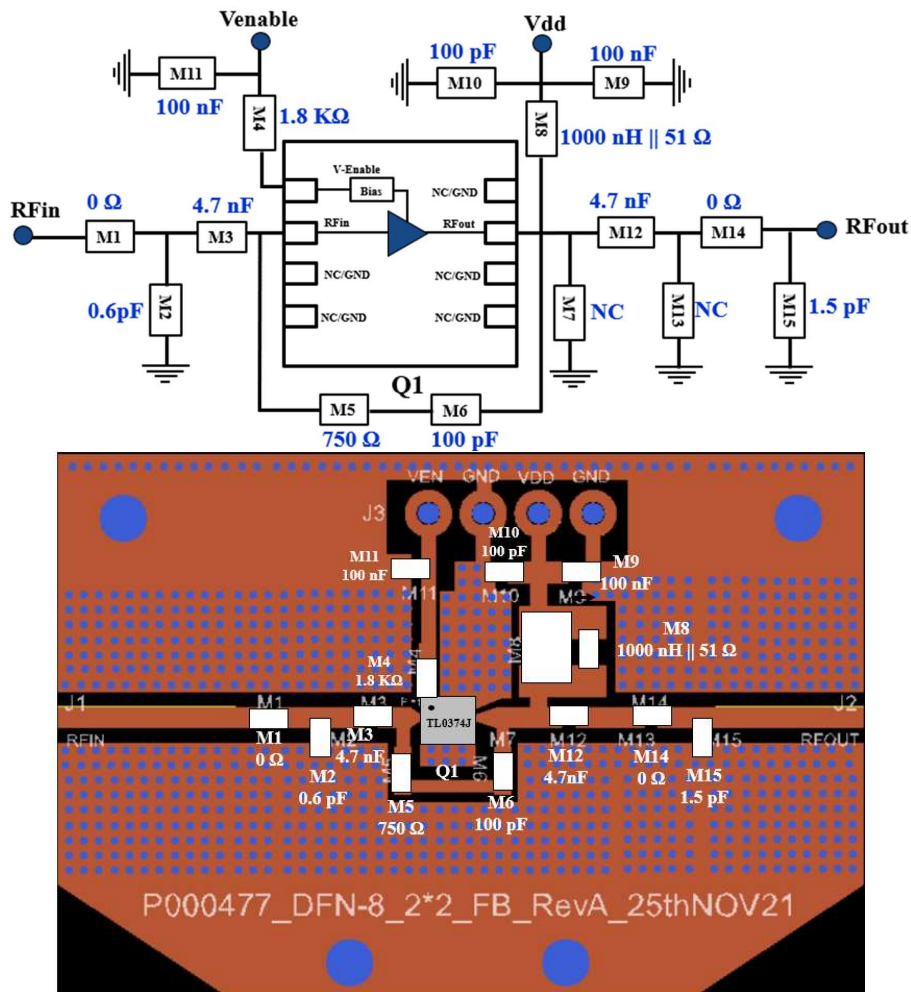

Figure 10.4 Schematic and EVB layout of the 30-2600 MHz EVB-D1

Table 10.4 BOM of the 30-2600 MHz EVB D1

Component ID	Value	Manufacturer	Recommended Part Number
M1, M14	0 Ω	Panasonic	ERJ-2GE0R00X
M2	0.6 pF	Murata	GJM1555C1HR60BB01D
M3, M12	4.7 nF, 50 V	Murata	GRM1885C1H472JA01D
M4	1.8 KΩ	Panasonic	ERJ-2RKF1801X
M5	750 Ω	KOA Speer	RK73H1ERTTP7500F
M6, M10	100 pF	AVX	04025A101JAT4A
M8	1 μH	Coil craft	PFL2512-102MEC
M8	51 Ω	ROHM Semiconductor	ESR03EZPJ510
M9, M11	100 nF	TDK	C1005X7R1H104K050BE
M15	1.5 pF	Murata	GJM1555C1H1R5BB01J
Q1	GaAs LNA	Tagore Tech	TL0374J
PCB	Rogers RO4350B, 20 mils, 1 oz copper		

10.5 EVB D2 30-2600 MHz

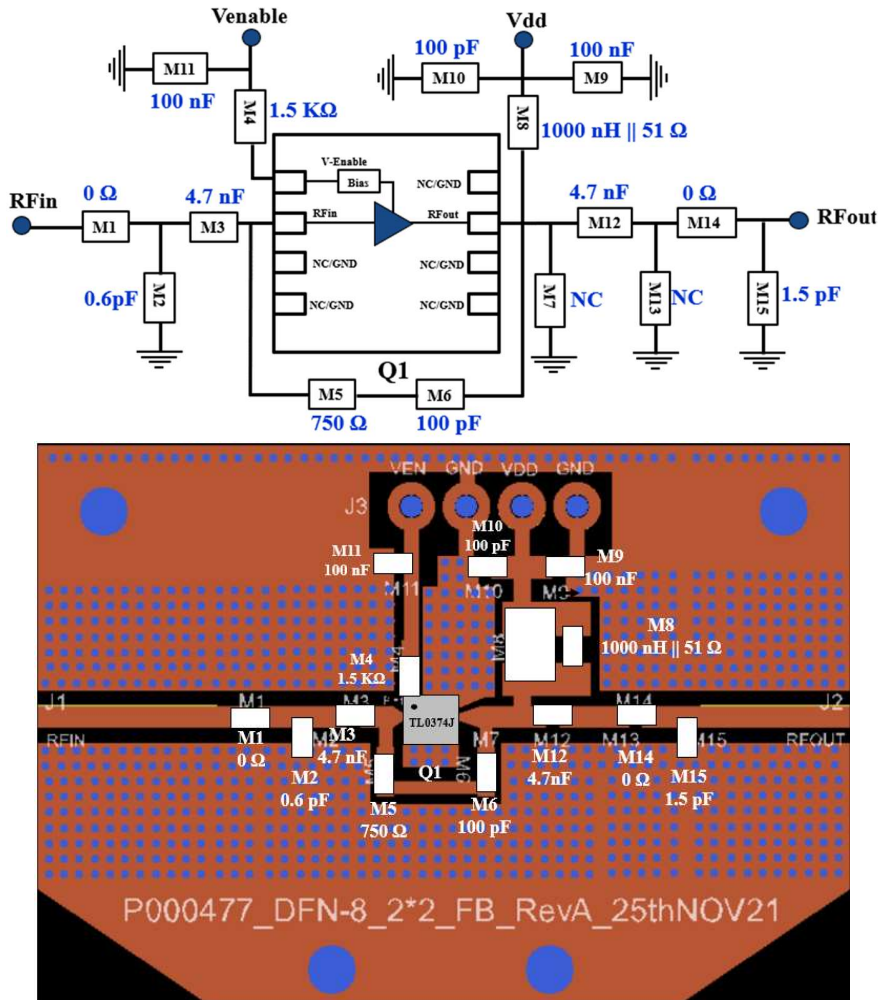

Figure 10.5 Schematic and EVB layout of the 30-2600 MHz EVB-D2

Table 10.5 BOM of the 30-2600 MHz EVB D2

Component ID	Value	Manufacturer	Recommended Part Number
M1, M14	0 Ω	Panasonic	ERJ-2GE0R00X
M2	0.6 pF	Murata	GJM1555C1HR60BB01D
M3, M12	4.7 nF, 50 V	Murata	GRM1885C1H472JA01D
M4	1.5 KΩ	Panasonic	ERJ-2RKf1501X
M5	750 Ω	KOA Speer	RK73H1ERTTP7500F
M6, M10	100 pF	AVX	04025A101JAT4A
M8	1 μH	Coil craft	PFL2512-102MEC
M8	51 Ω	R0HM Semiconductor	ESR03EZPJ510
M9, M11	100 nF	TDK	C1005X7R1H104K050BE
M15	1.5 pF	Murata	GJM1555C1H1R5BB01J
Q1	GaAs LNA	Tagore Tech	TL0374J
PCB	Rogers RO4350B, 20 mils, 1 oz copper		

10.6 EVB E 1000-2000 MHz

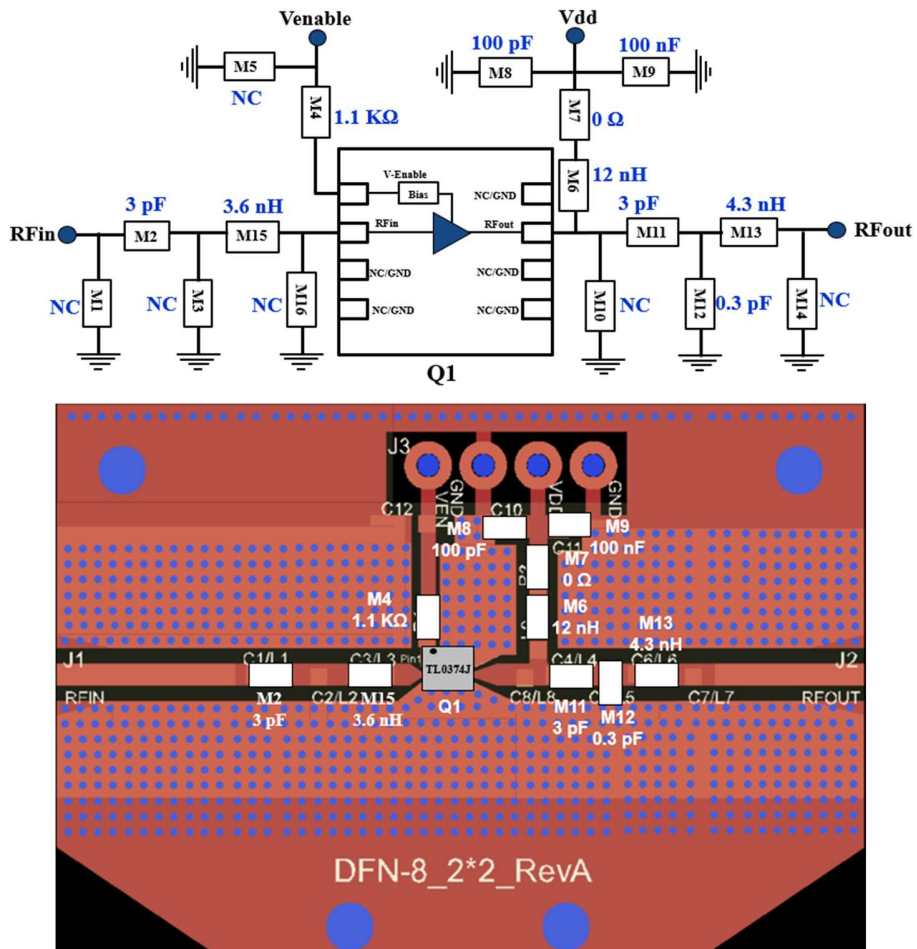
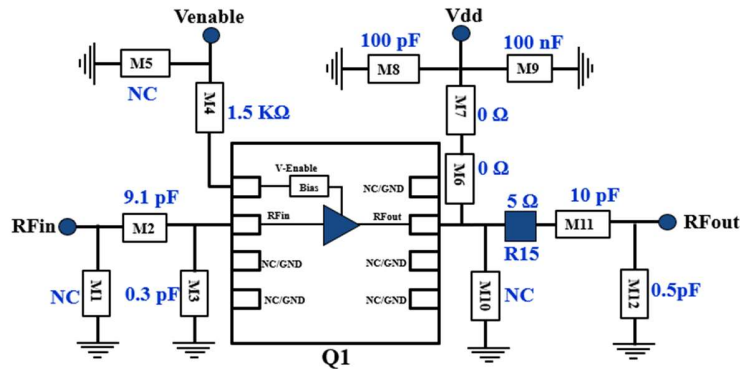

Figure 10.6 Schematic and EVB layout of the 1000-2000 MHz EVB-E

Table 10.6 BOM of the 1000-2000 MHz EVB E

Component ID	Value	Manufacturer	Recommended Part Number
M2, M11	3.0 pF	Murata	GJM1555C1H3R0BB01
M12	0.3 pF	Murata	GJM1555C1HR30BB01
M8	100 pF	AVX	04025A101JAT4A
M9	100 nF	TDK	C1005X7R1H104K050BE
M7	0 Ω	Panasonic	ERJ-2GE0R00X
M6	12 nH	Coil craft	0402HP-12NXE
M15	3.6 nH	Coil craft/Wurth Electronics	0402HP-3N6XGE/744916036
M14	1.1 KΩ	Panasonic	ERJ-2RKF1101X
M13	4.3 nH	Coil craft	0402HP-4N3XGE
Q1	GaAs LNA	Tagore Tech	TL0374J
PCB	Rogers RO4350B, 20 mils, 1 oz copper		

10.7 EVB F 4400-5000 MHz



R15 is the extra series cut that we made at output side RF line between M10 and M11 to accommodate 5 Ω resistor

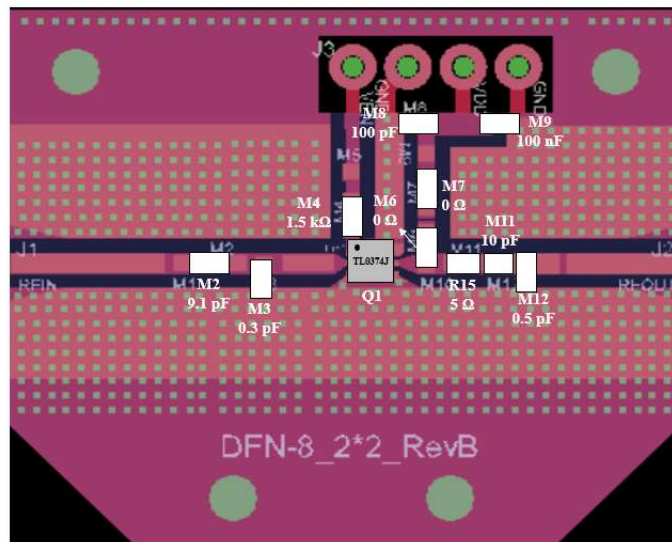

R15 is the extra series cut that we made at output side RF line between M10 and M11 to accommodate 5 Ω resistor. Please note that we have used TL0375 EVB REV B for this application and device used is TL0374.

Figure 10.7 Schematic and EVB layout of the 4400-5000 MHz EVB-E

Table 10.7 BOM of the 4400-5000 MHz EVB F

Component ID	Value	Manufacturer	Recommended Part Number
M2	9.1 pF	Murata	GJM1555C1H3R0BB01
M3	0.3 pF	Murata	GJM1555C1HR30BB01
M4	1.5 KΩ	Panasonic	ERJ-2RKF1501X
M6, M7	0 Ω	Panasonic	ERJ-2GE0R00X
M8	100 nF	TDK	C1005X7R1H104K050BE
M9	100 pF	AVX	04025A101JAT4A
M10	10 pF	Murata	GJM1555C1H100JB01
M12	0.5 pF	Murata	GJM1555C1HR50BB01
R15	5 Ω	KOA Speer	RK73H1ETTP4R99F
Q1	GaAs LNA	Tagore Tech	TL0374J
PCB		Rogers RO4350B, 20 mils, 1 oz copper	

11.0 Typical Characteristics

11.1 2500 – 2700 MHz tuned EVB (V_{dd}=5 V, I_{DQ}=60 mA), -40°C, 25°C, 85°C, 105 °C, Narrowband

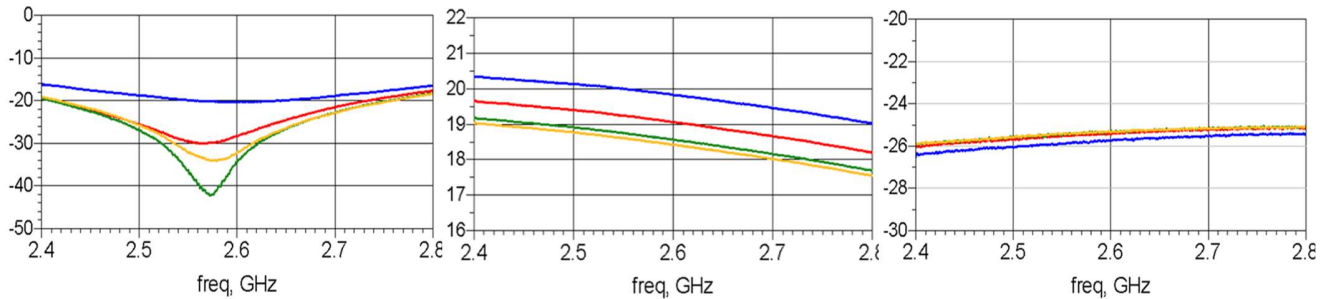

Figure 11.1.1: S11(IREL) vs Freq

Figure 11.1.2: S21(Gain) vs Freq

Figure 11.1.3: S12(Rev Iso) vs Freq

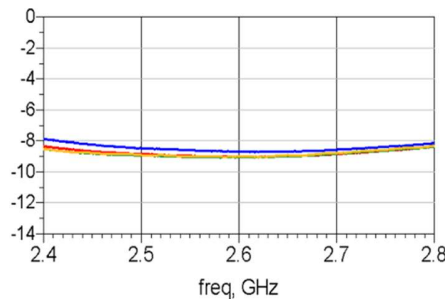

Figure 11.1.4: S22(ORL) vs Freq

11.2 2500 – 2700 MHz tuned EVB (V_{dd}=5 V, I_{DQ}=60 mA), -40°C, 25°C, 85°C, 105 °C, Broadband

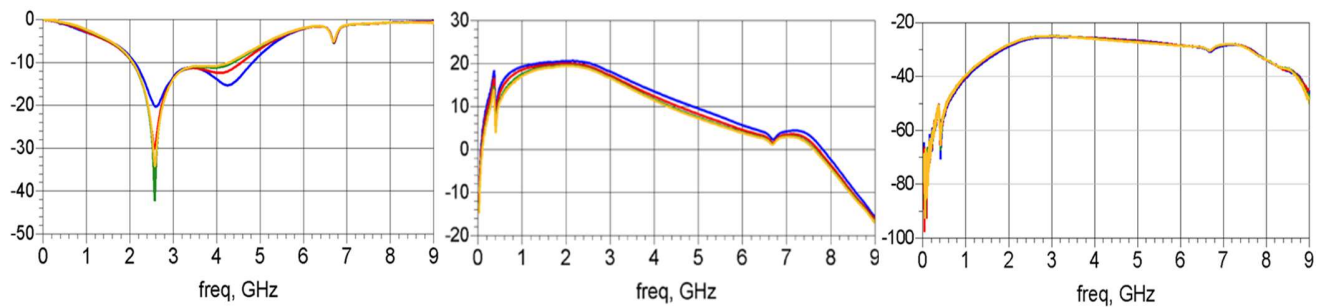

Figure 11.2.1: S11(IREL) vs Freq

Figure 11.2.2: S21(Gain) vs Freq

Figure 11.2.3: S12(Rev Iso) vs Freq

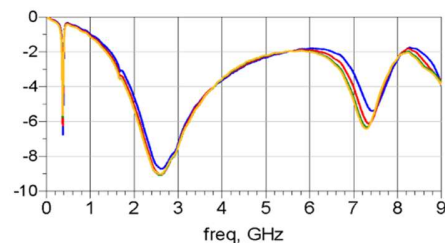

Figure 11.2.4: S22(ORL) vs Freq

11.3 2500 – 2700 MHz tuned EVB (Vdd=5 V, I_{DQ}=60 mA), -40°C, 25°C, 85°C, 105 °C, Large Signal Data

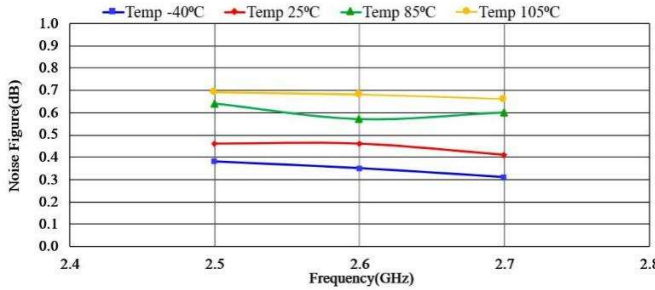

Figure 11.3.1: Noise Figure (EVb) vs Freq

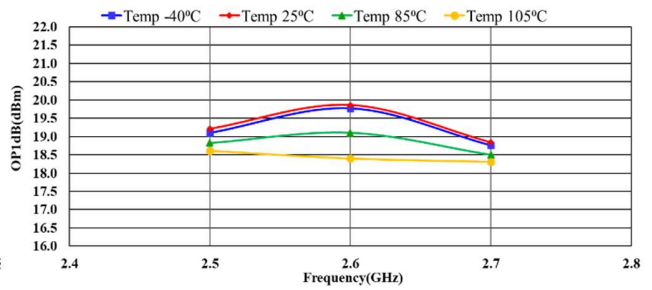

Figure 11.3.2: Output P1dB vs Freq

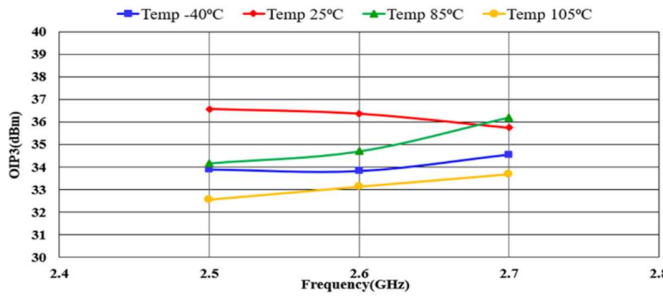

Figure 11.3.3: Output IP3 vs Freq

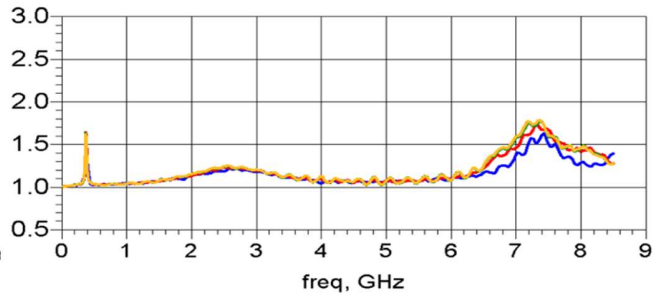

Figure 11.3.4: Mu1 vs Freq

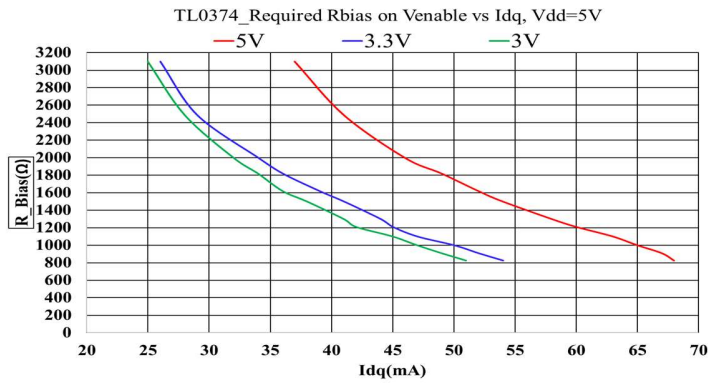

Figure 11.3.5: Rbias on Venable vs Idq

12.0 Test Procedures

Biasing Sequence

To properly bias the TL0374J-EVB-A, follow these steps:
Connect the supply Ground the Ground test point.

- Apply bias to the Venable=5 V test points.
- Apply bias to the Vdd=5 V test point.
- Apply an RF input signal.

The TL0374J-EVB-A is shipped fully assembled and tested. Figure 12.1 illustrates a basic test setup diagram for evaluating s-parameters, which includes gain, input output return loss and reverse isolation using a network analyzer. Follow these steps to complete the test setup and verify the operation of the TL0374J-EVB-A

1. Connect the Ground test point to the ground terminal of the power supply.
2. Connect the Venable and Vdd test points to the voltage output terminal of a 5 V supply that sources a current of approximately 60 mA.
3. Connect a calibrated network analyzer to the RF-in, and RF-out SMA connectors. Sweep the frequency from 1 GHz to 6 GHz and set the power to -25 dBm.

The TL0374J-EVB-A is expected to have a gain of 21.5 dB at 1.8 GHz. Refer to Table 9.1 for the expected results.

Additional test equipment is required for a comprehensive evaluation of the device's functions and performance.

For noise figure evaluation, use either a noise figure analyzer or a spectrum analyzer with a noise option. It is recommended to use a low excess noise ratio (ENR) noise source.

For third-order intercept point evaluation, use two signal generators and a spectrum analyzer. A high isolation power combiner is recommended.

For power compression and power handling evaluations, use a two-channel power meter and a signal generator. Ensure that the input power amplifier has sufficient power capacity. Test accessories such as couplers and attenuators must also have adequate power handling capabilities.

Please note that measurements conducted at the SMA connectors of the TL0374J-EVB-A include the losses of the SMA connectors and the PCB. The through line should be measured to calibrate the effects of the TL0374J-EVB-A. The through line consists of an RF input line and an RF output line that are connected to the device and have equal lengths.

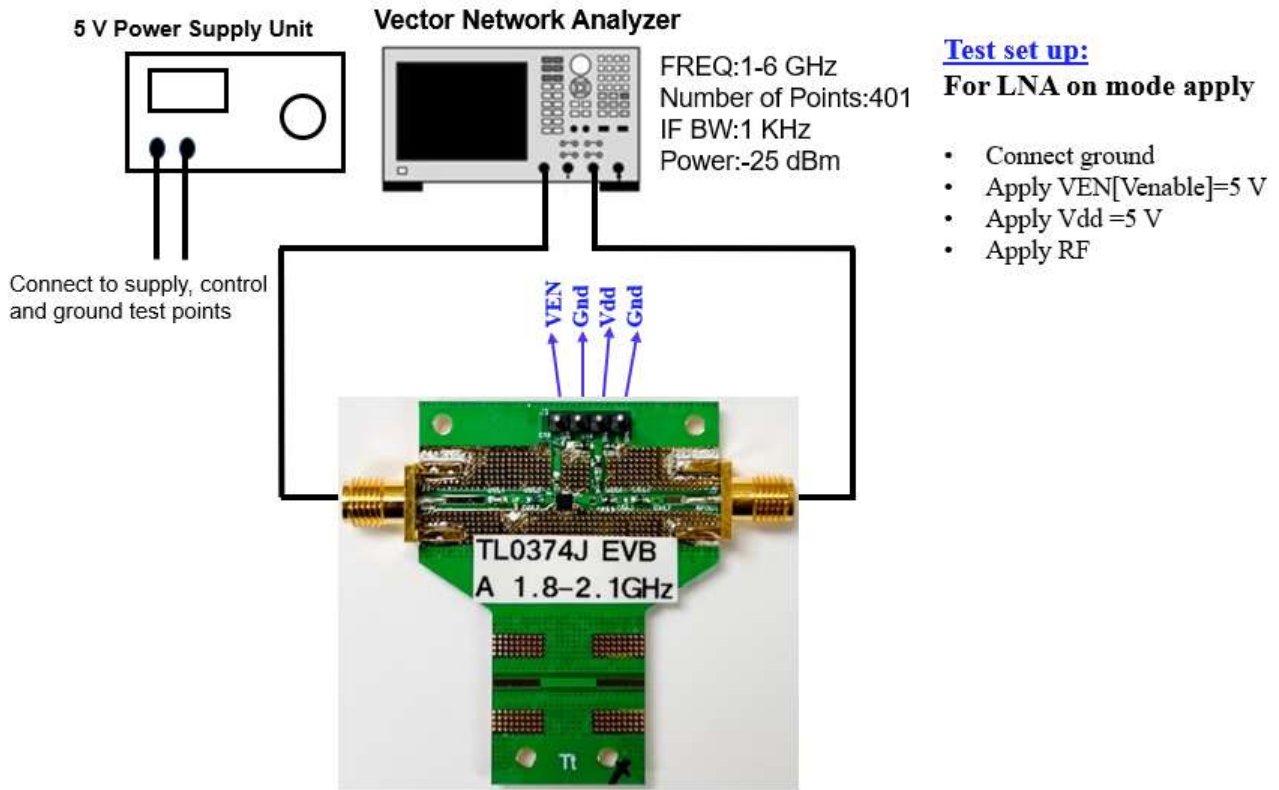

Figure 12.1 TEST Set Up Diagram

13.0 Device Package Information

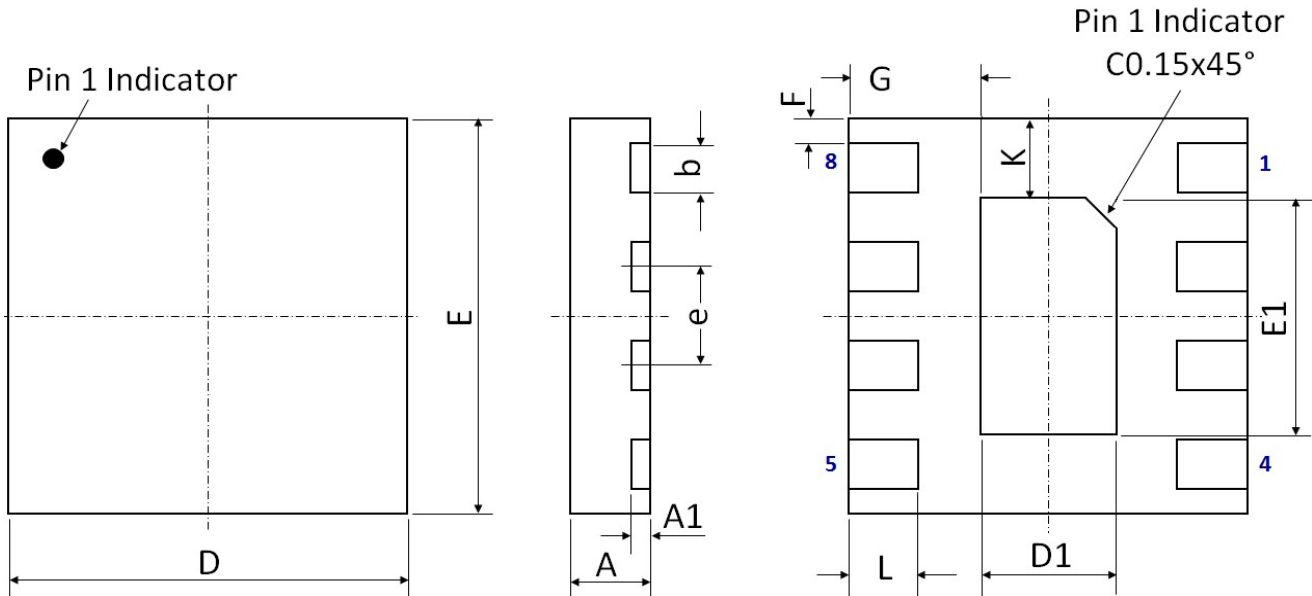

Figure 13.1 Device Package Drawing
 (All dimensions are in mm)

Table 13.1 Device Package Dimensions

Dimension (mm)	Value (mm)	Tolerance (mm)	Dimension (mm)	Value (mm)	Tolerance (mm)
A	0.75	±0.05	E	2.00 BSC	±0.05
A1	0.203	±0.02	E1	1.20	±0.05
b	0.25	±0.02	F	0.125	±0.02
D	2.00 BSC	±0.05	G	0.66	±0.03
D1	0.68	±0.03	L	0.35	±0.05
e	0.50 BSC	±0.05	K	0.40	±0.05

Note: Lead finish: Pure Sn without underlayer; Thickness: 7.5 µm ~ 20 µm (Typical 10 µm ~ 12 µm)

Attention:

Please refer to application notes [TN-001](#) and [TN-002](#) at <http://www.tagoretech.com> for PCB and soldering related guidelines.

14.0 PCB Land Design

Guidelines:

- [1] 2-layer PCB is recommended.
- [2] Via diameter is recommended to be 0.3 mm to prevent solder wicking inside the vias.
- [3] Thermal vias shall only be placed on the center pad and should be filled/plugged with solder or copper.
- [4] The maximum via number for the center pad is $1(X) \times 2(Y) = 2$

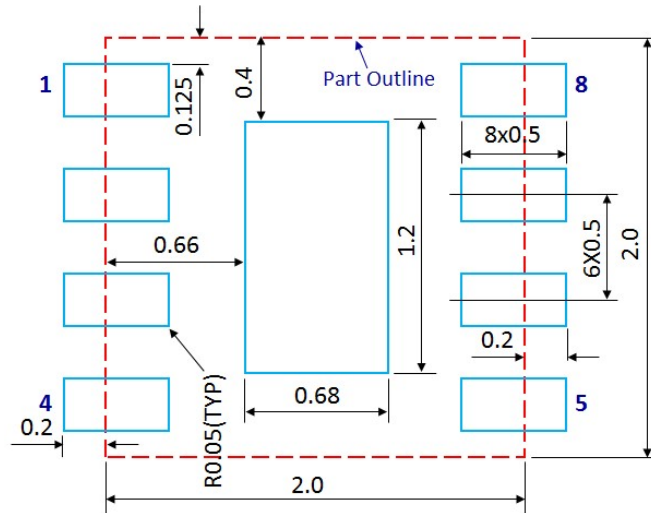

Figure 14.1 PCB Land Pattern
(Dimensions are in mm)

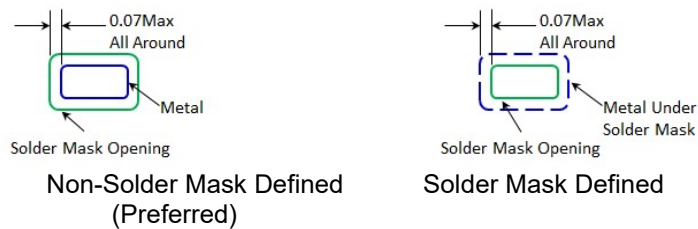

Figure 14.2 Solder Mask Pattern
(Dimensions are in mm)

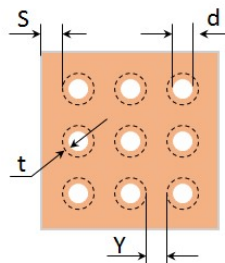

Figure 14.3 Thermal Via Pattern
(Recommended Values: $S \geq 0.15$ mm; $Y \geq 0.20$ mm; $d = 0.3$ mm; Plating Thickness $t = 25$ μ m or 50 μ m)

15.0 PCB Stencil Design

Guidelines:

- [1] Laser-cut, stainless steel stencil is recommended with electro-polished trapezoidal walls to improve the paste release.
- [2] Stencil thickness is recommended to be 125 μm .

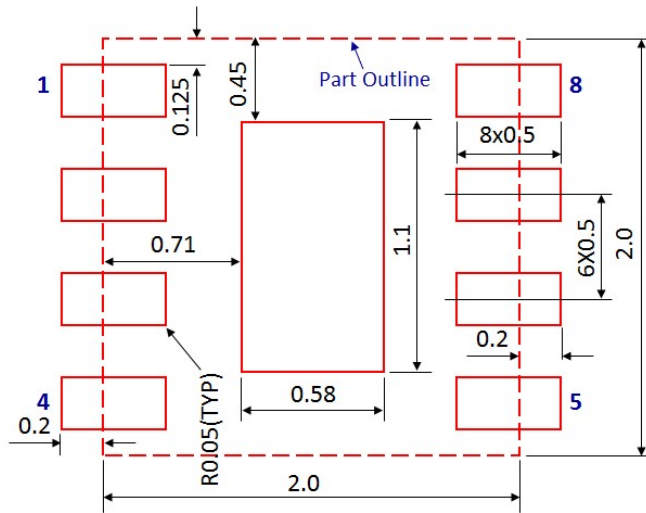

Figure 15.1 Stencil Openings
(Dimensions are in mm)

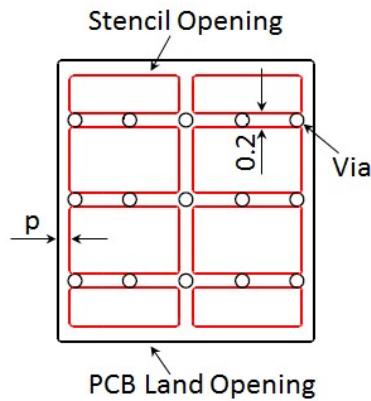

Figure 15.2 Stencil Openings Shall not Cover Via Areas If Possible
(Dimensions are in mm)

16.0 Tape and Reel Information

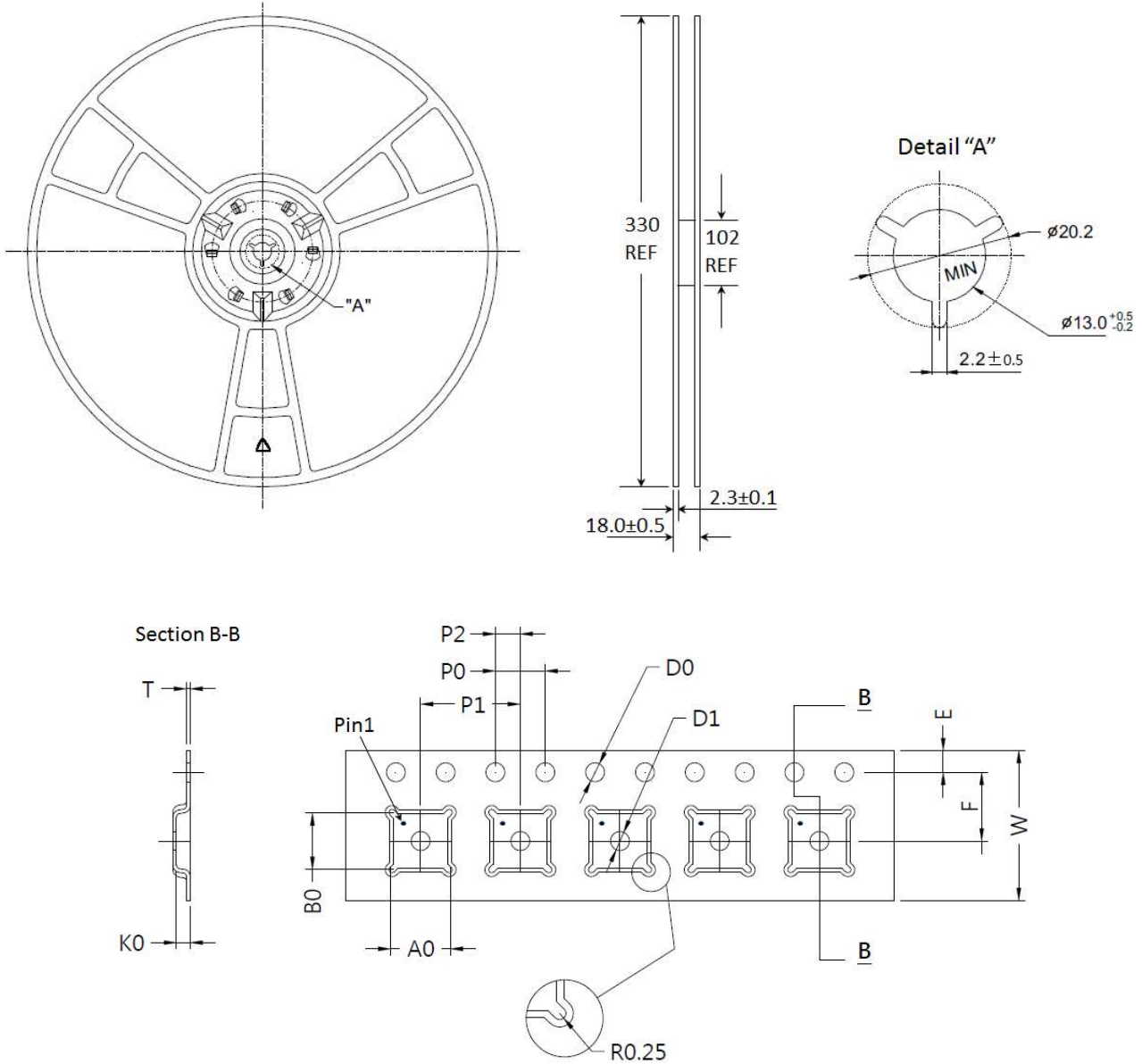

Figure 16.1 Tape and Reel Drawing

Table 16.1 Tape and Reel Dimensions

Dimension (mm)	Value (mm)	Tolerance (mm)	Dimension (mm)	Value (mm)	Tolerance (mm)
A0	2.20	±0.05	K0	1.00	±0.1
B0	2.20	±0.05	P0	4.00	±0.1
D0	1.5	+0.1	P1	4.00	±0.1
D1	1.00	Min	P2	2.00	±0.05
E	1.75	±0.10	T	0.30	±0.05
F	3.50	±0.05	W	8.00	+0.3/-0.1

Edition Revision 3.0 - 2024-11-29

Published by

Tagore Tech Inc.

601 W Campus Dr. Ste C1

Arlington Heights, IL 60004, USA

©2024 All Rights Reserved

Legal Disclaimer



The information provided in this document shall in no event be regarded as a guarantee of conditions or characteristics. Tagore Tech assumes no responsibility for the consequences of the use of this information, nor for any infringement of patents or of other rights of third parties which may result from the use of this information. No license is granted by implication or otherwise under any patent or patent rights of Tagore Tech. The specifications mentioned in this document are subject to change without notice.

Information

For further information on technology, delivery terms and conditions and prices, please contact Tagore Tech: support@tagoretech.com.

Looking for pricing, stock, or lifecycle information?

Click below to explore more details on WIN SOURCE:

-  [View TL0374J on WIN SOURCE](#)
-  [TagoreTech Information](#)

Optimize Your Supply Chain with WIN SOURCE Solutions

-  Global Sourcing Solution
-  Obsolete Management
-  Cost Control Management
-  Shortage Management
-  Alternative Solution
-  Excess Inventory Management