



LOW NOISE, HIGH IP3

# Monolithic Amplifier

## PMA-545G3+

50Ω 0.7 to 1.0 GHz

### THE BIG DEAL

- High Gain, 31 dB typ. at 0.9 GHz
- Low Noise Figure, typ. at 0.9 GHz
- High IP3, 34 dBm typ. at 0.9 GHz
- Output Power, up to +22dBm typ. at 0.9 GHz
- Single Positive Supply Voltage, 5V
- Micro-miniature size - 3mm x 3mm
- Aqueous washable
- Protected by U.S. patent no. 8,803,612

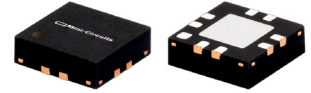

Generic photo used for illustration purposes only

CASE STYLE: DQ849

**+RoHS Compliant**

The +Suffix identifies RoHS Compliance. See our web site for RoHS Compliance methodologies and qualifications

### APPLICATIONS

- Cellular
- ISM
- GSM
- WCDMA
- LTE

### PRODUCT OVERVIEW

Mini-Circuits PMA-545G3+ is a E-PHEMT\* based Low Noise MMIC Amplifier operating from 0.7 to 1.0 GHz with a unique combination of low noise and high Gain making this amplifier ideal for sensitive receiver applications. This design operates on a single +5V supply and is internally matched to 50 Ohms.

### KEY FEATURES

Feature	Advantages
High Gain 31 dB	Incorporating multiple stages of amplification, the PMA-545G3+ provides high gain reducing cost and PCB board space.
Ultra Low Noise: 0.9 dB NF at 0.86 GHz	Excellent Noise Figure, measured in a 50 Ohm environment – without any external matching. When combined with high gain of this design, it suppresses second stage NF contribution.
High IP3: +33.4 dBm	Combining Low Noise and High IP3 makes this MMIC amplifier ideal for Low Noise Receiver Front End (RFE) giving the user advantages at both ends of the dynamic range: sensitivity & two-tone IM dynamic range
Output Power: +22 dBm at 1GHz	The PMA-545G3+ maintains consistent output power capability over the full operating temperature range making it ideal to be used in remote applications such as LNB's as the L Band driver stage
Internally Matched	No external matching elements required to achieve the advertised noise and output power over the full band
MCLP Package	Low Inductance, repeatable transitions, excellent thermal pad
Max Input Power +25 dBm	Ruggedized design operates up to input powers often seen at Receiver inputs.
High Reliability	Low, small signal operating current of 160 mA nominal maintains junction temperatures typically below 130°C at 85°C ground lead temperature

\*Enhancement mode Pseudomorphic High Electron Mobility Transistor.

REV. B  
ECO-010881  
PMA-545G3+  
TH/RS/CP/AM  
211124





LOW NOISE, HIGH IP3

# Monolithic Amplifier

## PMA-545G3+

### ELECTRICAL SPECIFICATIONS<sup>(1)</sup> AT 25°C, VD=5V, ZO=50Ω, (REFER TO CHARACTERIZATION CIRCUIT)

Parameter	Condition (GHz)	Min.	Typ.	Max.	Units
Frequency Range		0.7		1.0	GHz
DC Voltage (Vd)		4.8	5.0	5.2	V
DC Current			158	186	mA
Noise Figure	0.7		1.0	–	dB
	0.9		0.9	1.3	
	1.0		1.0	–	
Gain	0.7	–	31.6	–	dB
	0.9	28.3	31.3	34.7	
	1.0	–	31.1	–	
Input Return Loss	0.7		12.6		dB
	0.9		11.6		
	1.0		11.5		
Output Return Loss	0.7		17.7		dB
	0.9		16.6		
	1.0		16.3		
Output IP3	0.7		33.4		dBm
	0.9		33.4		
	1.0		33.6		
Output Power @ 1 dB compression <sup>(2)</sup>	0.7	–	21.7		dBm
	0.9	20	21.9		
	1.0	–	21.9		
DC Current Variation vs. Temperature <sup>(3)</sup>			-0.156		mA/°C
DC Current Variation vs. Voltage			0.027		mA/mV
Thermal Resistance			48		°C/W

### MAXIMUM RATINGS<sup>(4)</sup>

Parameter	Ratings
Operating Temperature <sup>(5)</sup>	-40°C to 85°C
Storage Temperature	-65°C to 150°C
Channel Temperature	150°C
DC Voltage (Pad 4,5,7)	6V
Power Dissipation	1.35W
Input Power	25dBm

- (1) Measured on Mini-Circuits Characterization test board TB-607-1+. See Characterization Test Circuit (Fig. 1)
- (2) Current increases at P1dB
- (3) (Current at 85°C - Current at -45°C)/130
- (4) Permanent damage may occur if any of these limits are exceeded. These maximum ratings are not intended for continuous normal operation.
- (5) Defined with reference to ground pad temperature.

### DC CURRENT HISTOGRAM

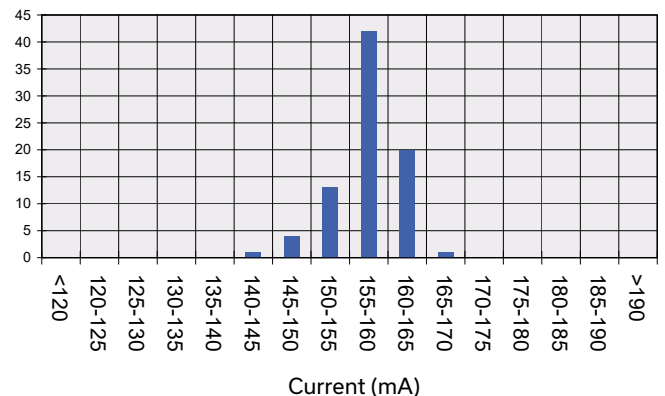



LOW NOISE, HIGH IP3

# Monolithic Amplifier

## PMA-545G3+

### SIMPLIFIED SCHEMATIC AND PAD DESCRIPTION



Function	Pad Number	Description (See Application Circuit, Fig. 2)
RF-IN	2	RF input pad (connected to RF-IN via C1)
RF-OUT & DC	5	RF output pad (connected to RF-OUT via blocking external cap C2, and Supply voltage Vs via RF Choke L2)
BIAS	4 & 7	Bias pad 4 connects to Vs via L1 & pad 7 connects to Vs
GND	paddle in center of bottom	Connected to ground
NOT USED	1,3,6,8	No internal connection; recommended use: per PCB Layout PL-346

### CHARACTERIZATION TEST CIRCUIT

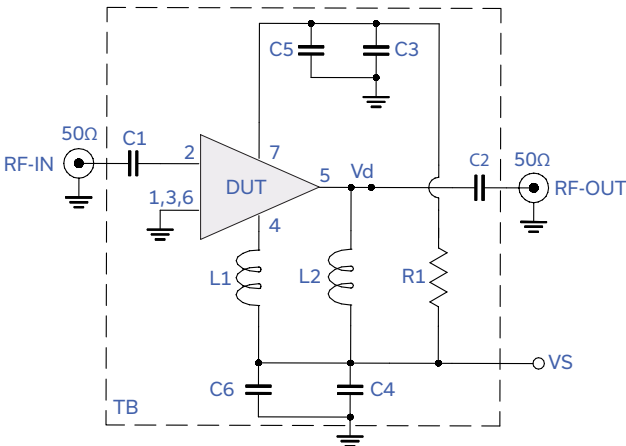

Fig 1. Block Diagram of Test Circuit used for characterization. (DUT soldered on Mini-Circuits Characterization Test Board TB-607-1) Gain, Output power at 1dB compression (P1dB), Output IP3 (OIP3), Noise Figure are measured using Agilent's N5242A PNA-X microwave network analyzer.

Conditions:

1. Gain: Pin=-25 dBm
2. Output IP3 (OIP3): Two tones, spaced 1 MHz apart, 0 dBm/tone at output.
3. Vs adjusted for 5V at device (Vd), compensating loss of bias tee.



LOW NOISE, HIGH IP3

# Monolithic Amplifier

## PMA-545G3+

### RECOMMENDED APPLICATION CIRCUIT

(refer to evaluation board for PCB Layout and component values)

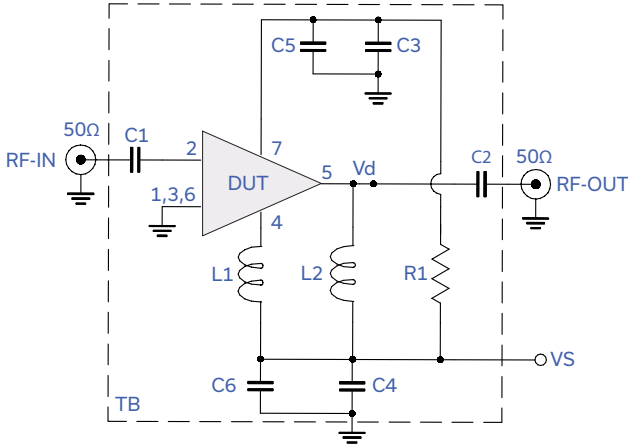

Component	Description
DUT	PMA-545G3+
C1, C2, C5, C6	100 pF
C3, C4	1μF
R1	0 Ω
L1	36 nH
L2	47 nH

### PRODUCT MARKING

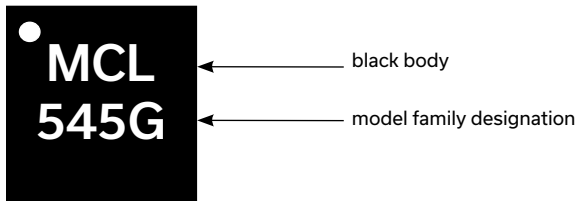

Marking may contain other features or characters for internal lot control



LOW NOISE, HIGH IP3

# Monolithic Amplifier

## PMA-545G3+

ADDITIONAL DETAILED TECHNICAL INFORMATION IS AVAILABLE ON OUR DASH BOARD. TO ACCESS [CLICK HERE](#)

Performance Data	Data Table Swept Graphs S-Parameter (S2P Files) Data Set (.zip file)
Case Style	Case Style: DQ849 Plastic package, exposed paddle, lead finish: tin-silver over nickel
Tape & Reel	F104
Standard quantities available on reel	Standard quantities available on reel: 7" reels with 20, 50, 100, 200, 500, 1K, or 2K devices
Suggested Layout for PCB Design	PL-346
Evaluation Board	TB-607-3+
Environmental Ratings	ENV08T1

### ESD RATING

Human Body Model (HBM): Class 1B (500V to <1000V) in accordance with ANSI/ESD STM 5.1 - 2001

Machine Model (MM): Class M1 (passes 40V) in accordance with ANSI/ESD STM5.2-1999; passes 40V

### MSL RATING

Moisture Sensitivity: MSL1 in accordance with IPC/JEDEC J-STD-020D

### MSL TEST FLOW CHART

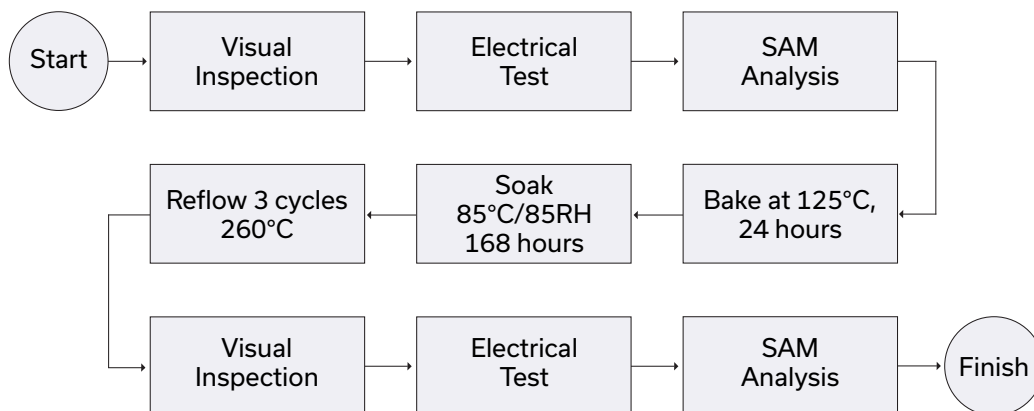

- NOTES**
- A. Performance and quality attributes and conditions not expressly stated in this specification document are intended to be excluded and do not form a part of this specification document.
  - B. Electrical specifications and performance data contained in this specification document are based on Mini-Circuit's applicable established test performance criteria and measurement instructions.
  - C. The parts covered by this specification document are subject to Mini-Circuits standard limited warranty and terms and conditions (collectively, "Standard Terms"); Purchasers of this part are entitled to the rights and benefits contained therein. For a full statement of the standard. Terms and the exclusive rights and remedies thereunder, please visit Mini-Circuits' website at [www.minicircuits.com/MCLStore/terms.jsp](http://www.minicircuits.com/MCLStore/terms.jsp)



## Looking for pricing, stock, or lifecycle information?

Click below to explore more details on WIN SOURCE:

 [View PMA-545G3+ on WIN SOURCE](#)

 [Mini-Circuits Information](#)

## Optimize Your Supply Chain with WIN SOURCE Solutions

-  Global Sourcing Solution
-  Obsolete Management
-  Cost Control Management
-  Shortage Management
-  Alternative Solution
-  Excess Inventory Management