

TRF1305B2 Dual-Channel, DC to > 6.5-GHz, 3-dB-Bandwidth, Fully Differential Amp

1 Features

- Three performance-optimized power gain variants:
 - 5 dB (TRF1305A2)
 - 10 dB (TRF1305B2)
 - 15 dB (TRF1305C2)
- Preset gain can be reduced with external resistors
- High large-signal bandwidth:
 - TRF1305B2: 7 GHz (3-dB), 6.5 GHz (1-dB)
- OP1dB (differential 100-Ω load):
 - 16 dBm (2 GHz), 12.5 dBm (4 GHz)
- OIP3: 34 dBm (2 GHz), 24 dBm (4 GHz)
- Noise Figure: 10.2 dB (2 GHz), 12 dB (4 GHz)
- Slew rate: 25 kV/μs
- Large input (± 1 V) and output (± 0.5 V) common-mode voltage ranges
- Flexible configurations and modes:
 - Single-ended input, differential output (S2D)
 - Differential input, differential output (D2D)
 - Single-ended output (limited performance)
 - AC- or DC-coupled input/output
 - Adjustable output common-mode voltage
 - Input common-mode range extension mode
- Supports 5-V, flexible single or split supplies
- Active power dissipation: 500 mW per channel
- Power-down for each channel

2 Applications

- RF sampling or GSPS ADC driver
- [Test and measurement](#)
- [Wireless communications test](#)
- [High-speed data acquisition](#)
- [Oscilloscopes \(DSOs\)](#)
- [High speed digitizer](#)
- [Spectrum analyzer](#)
- [Vector signal transceiver \(VST\)](#)
- Common-mode level shifting
- RF active balun
- I/Q mixer interface

3 Description

The TRF1305B2 is a very high performance, closed-loop, dual-channel RF amplifier that has an operational bandwidth from true-dc to > 6.5 GHz. The device has excellent performance to drive high-speed, high-performance ADCs, such as the [ADC12DJ5200RF](#) and [ADC32RF5x](#) with a dc- or ac-coupled interface. The amplifier is optimized for use in RF, zero and complex IF, and high-speed time-domain applications. The device is optimized for performance in the preset gain configuration. If a lower-than-preset gain is desired, use external resistors.

The TRF1305B2 features a VO_{CM} pin that allows setting different output common-mode and input common-mode voltages (for example, for level-shifting or for most IQ down-converter ADC-interface applications that have differing dc common-mode voltages). The floating 2-rail split or single-supply option, and a MODE pin that allows extending the input common-mode range closer to the supplies. High channel-to-channel isolation allows the device to be used in a complex IQ transmit or receive signal chain without loss of signal integrity.

The TRF1305B2 has a feature to power down each channel individually. The device is fabricated in TI's proprietary advanced BiCMOS process and is available in a space-saving, 2.5-mm × 3.0-mm, 16-pin, WQFN-FCRLF package.

Device Information

PART NUMBER ⁽¹⁾	D2D POWER GAIN	PACKAGE ⁽²⁾
TRF1305A2 ⁽³⁾	5 dB	RYP (WQFN-FCRLF, 16)
TRF1305B2	10 dB	
TRF1305C2 ⁽³⁾	15 dB	

(1) See the [Device Comparison Table](#).

(2) For more information, see [Section 11](#).

(3) Preview information (not Production Data).

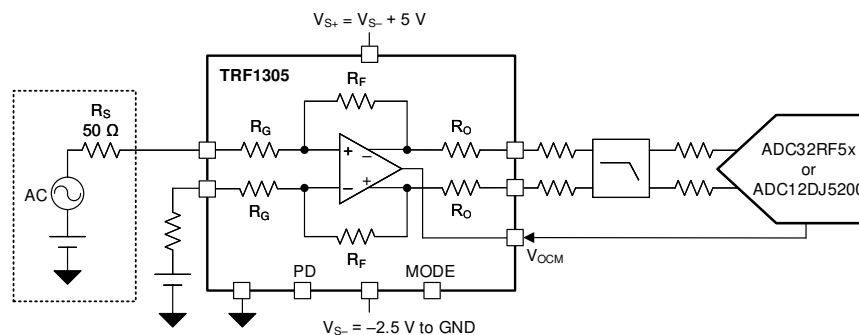

TRF1305 Driving a High-Speed ADC



Table of Contents

1 Features	1	7.4 Device Functional Modes.....	16
2 Applications	1	8 Application and Implementation	18
3 Description	1	8.1 Application Information.....	18
4 Device Comparison	2	8.2 Typical Application.....	21
5 Pin Configuration and Functions	3	8.3 Power Supply Recommendations.....	23
6 Specifications	4	8.4 Layout.....	23
6.1 Absolute Maximum Ratings.....	4	9 Device and Documentation Support	25
6.2 ESD Ratings.....	4	9.1 Receiving Notification of Documentation Updates.....	25
6.3 Recommended Operating Conditions.....	4	9.2 Support Resources.....	25
6.4 Thermal Information.....	4	9.3 Trademarks.....	25
6.5 Electrical Characteristics - TRF1305B2.....	5	9.4 Electrostatic Discharge Caution.....	25
6.6 Typical Characteristics - TRF1305B2.....	8	9.5 Glossary.....	25
7 Detailed Description	14	10 Revision History	25
7.1 Overview.....	14	11 Mechanical, Packaging, and Orderable Information	25
7.2 Functional Block Diagram.....	14		
7.3 Feature Description.....	15		

4 Device Comparison

DEVICE	CHANNEL COUNT	GAIN	PACKAGE
TRF1305A1	1	15 dB	RPV (WQFN, 12)
TRF1305B1	1	10 dB	RPV (WQFN, 12)
TRF1305C1	1	5 dB	RPV (WQFN, 12)
TRF1305A2	2	15 dB	RYP (WQFN, 16)
TRF1305B2	2	10 dB	RYP (WQFN, 16)
TRF1305C2	2	5 dB	RYP (WQFN, 16)

5 Pin Configuration and Functions

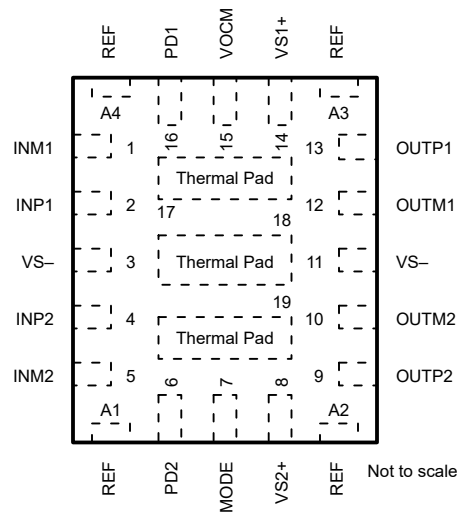

Figure 5-1. RYP Package (Dual-Channel), 16-Pin WQFN-FCRLF (Top View)

Table 5-1. Pin Functions

PIN		TYPE ⁽¹⁾	DESCRIPTION
NAME	NO.		
INM1	1	I	Negative side of differential input signal for Channel 1 (Ch1).
INM2	5	I	Negative side of differential input signal for Channel 2 (Ch2).
INP1	2	I	Positive side of differential input signal for Channel 1 (Ch1).
INP2	4	I	Positive side of differential input signal for Channel 2 (Ch2).
MODE	7	I	Mode selection pin. For details, see Section 7.4.1 .
OUTM1	12	O	Negative side of differential output signals for Ch1.
OUTM2	10	O	Negative side of differential output signals for Ch2.
OUTP1	13	O	Positive side of differential output signals for Ch1.
OUTP2	9	O	Positive side of differential output signals for Ch2.
PD1	16	I	Power-down signal for Ch1, referenced to thermal pad. Supports both 1.8-V and 3.3-V logic. Logic 0 or open = channel enabled. Logic 1 = channel powered down.
PD2	6	I	Power-down signal for Ch2, referenced to thermal pad. Supports both 1.8-V and 3.3-V Logic. Logic 0 or open = channel enabled. Logic 1 = channel powered down.
REF	A1, A2, A3, A4	–	Reference for RF signals and PD control voltage. Connect to same potential as the thermal pad.
VOCM	15	I	Output common-mode voltage input pin. Common for both channels. Floating the pin sets the output common-mode voltage to $V_{S-} + 2.5\text{ V}$.
VS-	3, 11	P	Negative supply pin. Common for both channels.
VS1+	14	P	Positive supply pin for Ch1. V_{S1+} must be equal to V_{S2+} .
VS2+	8	P	Positive supply pin for Ch2. V_{S1+} must be equal to V_{S2+} .
Thermal Pad	17, 18, 19	–	PAD. Reference for RF signals and PD control voltage. Also serves as thermal pads. Connect to heat-dissipating V_{S-} (recommended) or GND plane on the board.

(1) I = input, P = power, O = output

6 Specifications

6.1 Absolute Maximum Ratings

over operating free-air temperature range (unless otherwise noted)⁽¹⁾

		MIN	MAX	UNIT
V_{S-}	Negative supply voltage, referenced to thermal pad	-3	3	V
V_{S1+}, V_{S2+}	Positive supply voltage	-0.3	$V_{S-} + 5.5$	V
V_S	Total supply voltage, $V_S = V_{S+} - V_{S-}$	-0.3	5.5	V
P_{IN}	Input RF power		20	dBm
V_{PD}	PD pin voltage, referenced to thermal pad, $V_{S+} \geq 3.3$ V	-0.3	3.6	V
	PD pin voltage, referenced to thermal pad, $V_{S+} < 3.3$ V	-0.3	$V_{S+} + 0.3$	V
V_{OCM}	VOCM pin voltage	$V_{S-} + 1$	$V_{S-} + 4$	V
V_{MODE}	MODE pin voltage	$V_{S-} - 0.3$	$V_{S-} + 3.3$	V
T_J	Junction temperature	-40	150	°C
T_{stg}	Storage temperature	-40	150	°C

- (1) Operation outside the *Absolute Maximum Ratings* may cause permanent device damage. Absolute maximum ratings do not imply functional operation of the device at these or any other conditions beyond those listed under *Recommended Operating Conditions*. If briefly operating outside the *Recommended Operating Conditions* but within the *Absolute Maximum Ratings*, the device may not sustain damage, but it may not be fully functional. Operating the device in this manner may affect device reliability, functionality, performance, and shorten the device lifetime.

6.2 ESD Ratings

			VALUE	UNIT
$V_{(ESD)}$	Electrostatic discharge	Human body model (HBM), per ANSI/ESDA/JEDEC JS-001, all pins ⁽¹⁾	±1000	V
		Charged device model (CDM), per ANSI/ESDA/JEDEC JS-002, all pins ⁽²⁾	±500	

- (1) JEDEC document JEP155 states that 500-V HBM allows safe manufacturing with a standard ESD control process.
 (2) JEDEC document JEP157 states that 250-V CDM allows safe manufacturing with a standard ESD control process.

6.3 Recommended Operating Conditions

over operating free-air temperature range (unless otherwise noted)

		MIN	NOM	MAX	UNIT
V_{S+}	Positive supply voltage	2.5		5	V
V_{S-}	Negative supply voltage	-2.5		0	V
V_S	Total supply voltage, $V_S = V_{S+} - V_{S-}$		5		V
T_J	Junction temperature	-40		125	°C

6.4 Thermal Information

THERMAL METRIC ⁽¹⁾		TRF1305x2		UNIT
		RYP (WQFN-FCRLF)		
		16 PINS		
$R_{\theta JA}$	Junction-to-ambient thermal resistance	51.8		°C/W
$R_{\theta JC(top)}$	Junction-to-case (top) thermal resistance	24.5		°C/W
$R_{\theta JB}$	Junction-to-board thermal resistance	14.5		°C/W
Ψ_{JT}	Junction-to-top characterization parameter	1.4		°C/W
Ψ_{JB}	Junction-to-board characterization parameter	14.3		°C/W
$R_{\theta JC(bot)}$	Junction-to-case (bottom) thermal resistance	10.7		°C/W

- (1) For information about traditional and new thermal metrics, see the [Semiconductor and IC Package Thermal Metrics](#) application report.

6.5 Electrical Characteristics - TRF1305B2

at $T_A = 25^\circ\text{C}$, $V_{S+} = 5\text{ V}$, $V_{S-} = 0\text{ V}$, floating VO_{CM}, PD_x, and MODE pins, $V_{ICM} = \text{midsupply}$, D2D ac-coupled input/output with differential source impedance (Z_S) = 100 Ω , differential output load (Z_L) = 100 Ω , external input resistor network (see Figure 8-3), and resistor network included as part of DUT specifications (unless otherwise noted)

PARAMETER		TEST CONDITIONS	MIN	TYP	MAX	UNIT
AC PERFORMANCE						
SSBW	Small-signal 3-dB bandwidth	$P_{IN} = -20\text{ dBm}$ at each input		7.6		GHz
	Small-signal 1-dB bandwidth			6.5		
LSBW	Large-signal 3-dB bandwidth	Differential $P_{IN} = -3\text{ dBm}$		7		GHz
	Large-signal 1-dB bandwidth			6.5		
S21	Power gain	$f = 4\text{ GHz}$		9.8		dB
	Gain variation over temperature	$f = 4\text{ GHz}$, $T_A = -40^\circ\text{C}$ to $+85^\circ\text{C}$		0.7		
S11	Input return loss	$f = 10\text{ MHz}$ to 7.5 GHz		-10		dB
S12	Reverse isolation	$f < 10\text{ GHz}$ (when enabled)		-20		dB
G_{IMB}	Differential gain imbalance	$f < 5\text{ GHz}$, S2D, $P_{IN} = -20\text{ dBm}$ with 50- Ω source impedance		± 0.2		dB
PH_{IMB}	Differential phase imbalance			± 2		$^\circ$
OP1dB	Output 1-dB compression point	$f = 500\text{ MHz}$		15.7		dBm
		$f = 1\text{ GHz}$		16		
		$f = 2\text{ GHz}$		16		
		$f = 3\text{ GHz}$		15		
		$f = 4\text{ GHz}$		12.5		
		$f = 5\text{ GHz}$		11.3		
HD2	Second-order harmonic distortion	$f = 500\text{ MHz}$, $V_O = 2\text{ V}_{PP}$		-73		dBc
		$f = 1\text{ GHz}$, $V_O = 2\text{ V}_{PP}$		-70		
		$f = 2\text{ GHz}$, $V_O = 2\text{ V}_{PP}$		-60		
		$f = 3\text{ GHz}$, $V_O = 2\text{ V}_{PP}$		-55		
		$f = 4\text{ GHz}$, $V_O = 2\text{ V}_{PP}$		-46		
HD3	Third-order harmonic distortion	$f = 500\text{ MHz}$, $V_O = 2\text{ V}_{PP}$		-68		dBc
		$f = 1\text{ GHz}$, $V_O = 2\text{ V}_{PP}$		-60		
		$f = 2\text{ GHz}$, $V_O = 2\text{ V}_{PP}$		-55		
		$f = 3\text{ GHz}$, $V_O = 2\text{ V}_{PP}$		-53		
		$f = 4\text{ GHz}$, $V_O = 2\text{ V}_{PP}$		-47		
OIP2	Output second-order intercept point	$f = 500\text{ MHz}$, $P_O = 1\text{ dBm}$ per tone, 2-MHz spacing		75		dBm
		$f = 1\text{ GHz}$, $P_O = 1\text{ dBm}$ per tone, 2-MHz spacing		72		
		$f = 2\text{ GHz}$, $P_O = 1\text{ dBm}$ per tone, 2-MHz spacing		60		
		$f = 3\text{ GHz}$, $P_O = 1\text{ dBm}$ per tone, 2-MHz spacing		53		
		$f = 4\text{ GHz}$, $P_O = 1\text{ dBm}$ per tone, 2-MHz spacing		45		
		$f = 5\text{ GHz}$, $P_O = 1\text{ dBm}$ per tone, 2-MHz spacing		49		

6.5 Electrical Characteristics - TRF1305B2 (continued)

at $T_A = 25^\circ\text{C}$, $V_{S+} = 5\text{ V}$, $V_{S-} = 0\text{ V}$, floating VO_{CM}, PD_x, and MODE pins, $V_{ICM} = \text{midsupply}$, D2D ac-coupled input/output with differential source impedance (Z_S) = 100 Ω , differential output load (Z_L) = 100 Ω , external input resistor network (see Figure 8-3), and resistor network included as part of DUT specifications (unless otherwise noted)

PARAMETER		TEST CONDITIONS	MIN	TYP	MAX	UNIT
OIP3	Output third-order intercept point	f = 500 MHz, $P_O = 1\text{ dBm}$ per tone, 2-MHz spacing		43.5		dBm
		f = 1 GHz, $P_O = 1\text{ dBm}$ per tone, 2-MHz spacing		39.2		
		f = 2 GHz, $P_O = 1\text{ dBm}$ per tone, 2-MHz spacing		34		
		f = 3 GHz, $P_O = 1\text{ dBm}$ per tone, 2-MHz spacing		30.5		
		f = 4 GHz, $P_O = 1\text{ dBm}$ per tone, 2-MHz spacing		24		
		f = 5 GHz, $P_O = 1\text{ dBm}$ per tone, 2-MHz spacing		21		
NF	Noise figure	f = 500 MHz		8.4		dB
		f = 1 GHz		8.8		
		f = 2 GHz		10.2		
		f = 4 GHz		12		
		f = 5 GHz		12.4		
NSD	Output noise spectral density	f = 500 MHz		-155.6		dBm/Hz
		f = 1 GHz		-155.2		
		f = 2 GHz		-153.8		
		f = 4 GHz		-152		
		f = 5 GHz		-151.6		
DC PERFORMANCE						
V_{OD-MAX}	Max differential output voltage	f = 1 GHz		4		V_{PP}
	Slew rate	2-V V_O step, S2D configuration, $V_{S+} = 2.5\text{ V}$, $V_{S-} = -2.5\text{ V}$		25		kV/ μs
	Output differential offset voltage			± 3		mV
	Overdrive recovery time	From 2 \times overdrive of each SE output to each output voltage settling to $< \pm 50\text{ mV}$		6		ns
COMMON-MODE						
V_{ICM}	Input common-mode voltage	Default range ⁽¹⁾	$V_{S-} + 1.5$	$V_{S-} + 3.5$		V
V_{OCM}	Output common-mode voltage		$V_{S-} + 2$	$V_{S-} + 3$		V
	Output common-mode offset voltage from V_{OCM} voltage			± 10		mV
IMPEDANCE						
Z_{in-SE}	Single ended input impedance	At INP _x pin with appropriate termination on INM _x pin		47		Ω
Z_{O-DIFF}	Differential output impedance	f = near dc		8		Ω

6.5 Electrical Characteristics - TRF1305B2 (continued)

at $T_A = 25^\circ\text{C}$, $V_{S+} = 5\text{ V}$, $V_{S-} = 0\text{ V}$, floating V_{OCM}, PD_x, and MODE pins, $V_{ICM} = \text{midsupply}$, D2D ac-coupled input/output with differential source impedance (Z_S) = 100 Ω , differential output load (Z_L) = 100 Ω , external input resistor network (see [Figure 8-3](#)), and resistor network included as part of DUT specifications (unless otherwise noted)

PARAMETER		TEST CONDITIONS	MIN	TYP	MAX	UNIT
CHANNEL-TO-CHANNEL PERFORMANCE						
	Channel-to-channel amplitude matching	$f < 2\text{ GHz}$		0.05		dB
		$f < 5\text{ GHz}$		0.3		
	Isolation	$f < 2\text{ GHz}$		-55		dB
		$f < 5\text{ GHz}$		-50		
POWER SUPPLY						
I_{QA}	Active quiescent current	Both channels active		180		mA
		One channel active, other is powered down		102		
I_{QPD}	Power-down quiescent current	Both channels powered down		25		mA
POWER DOWN						
V_{PD_Hi}	PD pin logic high	Referenced to PAD, see Section 6.1	1.35			V
V_{PD_Lo}	PD pin logic low	Referenced to PAD, see Section 6.1			0.3	V
I_{PD_Bias}	PD bias current (current on PD pin)	PD = high (1.8-V logic)		15		μA
		PD = high (3.3-V logic)		30		
t_{ON}	Turn-on time	From 50% V_{PD} transition to 90% RF out		25		ns
t_{OFF}	Turn-off time	From 50% V_{PD} transition to 10% RF out		20		ns

(1) V_{ICM} range can be extended closer to V_{S+} or V_{S-} in D2D configuration. See [Section 7.4.1](#) for more details.

6.6 Typical Characteristics - TRF1305B2

at $T_A = 25^\circ\text{C}$, $V_{S+} = 5\text{ V}$, $V_{S-} = 0\text{ V}$, floating VO_{CM}, PD_X, and MODE pins, $V_{ICM} = \text{midsupply}$, D2D ac-coupled input/output configuration with $Z_S = 100\ \Omega$, $Z_L = 100\ \Omega$, external input resistor network (see Figure 8-3), ambient temperatures shown, and resistor network included as part of DUT characteristic plots (unless otherwise noted)

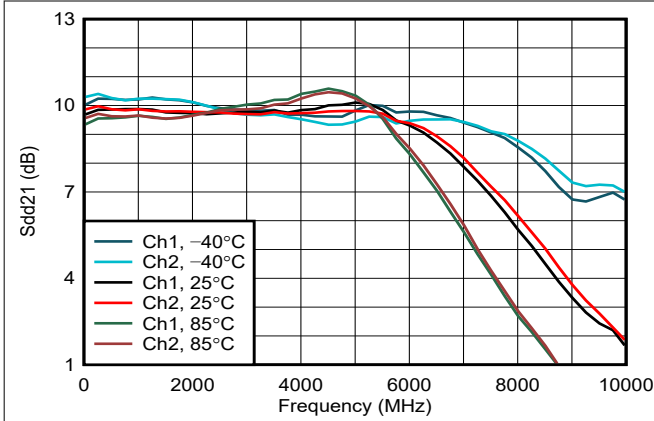

$P_{IN} = -20\text{ dBm}$ at each input pin with 50- Ω source

Figure 6-1. Power Gain (S21) Across Temperature

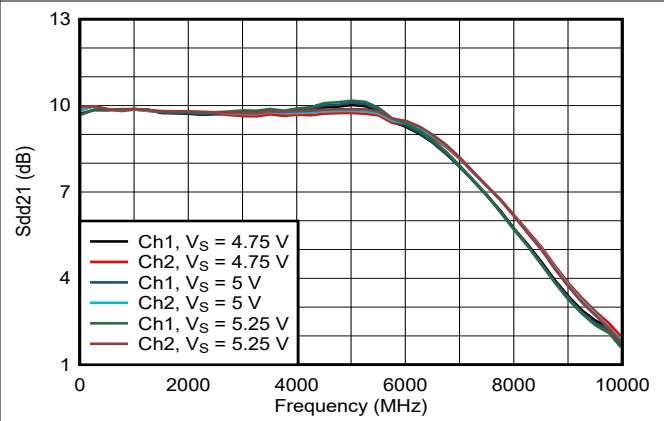

$P_{IN} = -20\text{ dBm}$ at each input pin with 50- Ω source

Figure 6-2. Power Gain (S21) Across Supply Voltage

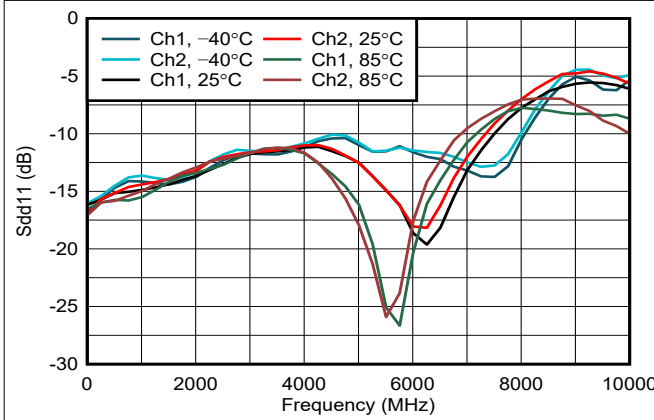

$P_{IN} = -20\text{ dBm}$ at each input pin with 50- Ω source

Figure 6-3. Input Return Loss (S11) Across Temperature

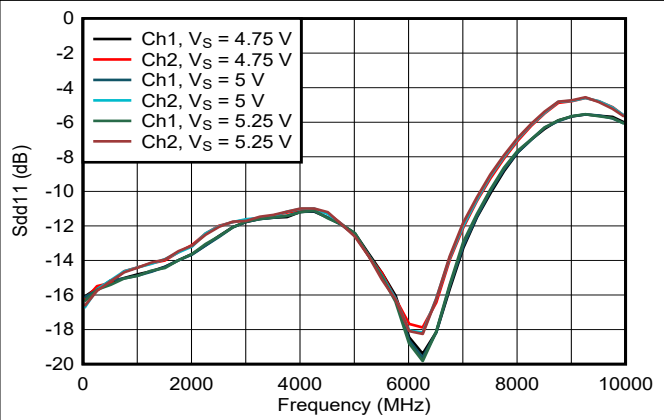

$P_{IN} = -20\text{ dBm}$ at each input pin with 50- Ω source

Figure 6-4. Input Return Loss (S11) Across Supply Voltage

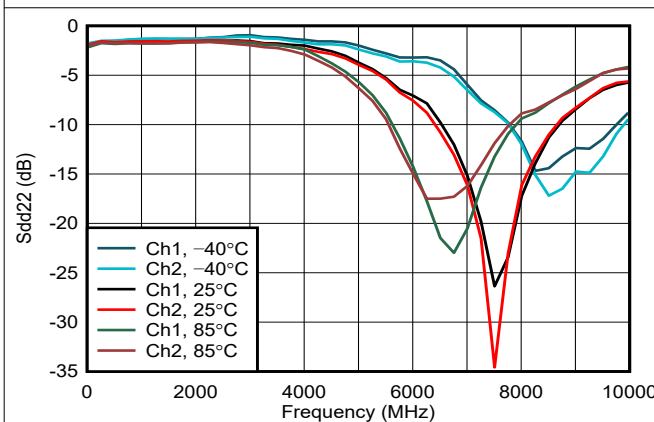

$P_{IN} = -20\text{ dBm}$ at each input pin with 50- Ω source

Figure 6-5. Output Return Loss (S22) Across Temperature

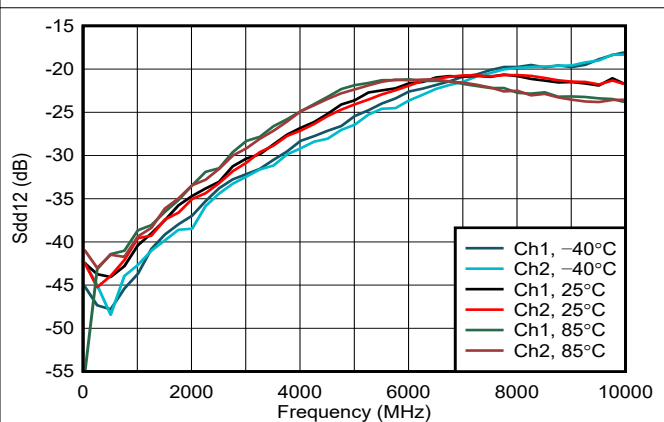

$P_{IN} = -20\text{ dBm}$ at each input pin with 50- Ω source

Figure 6-6. Reverse Isolation (S12) Across Temperature

6.6 Typical Characteristics - TRF1305B2 (continued)

at $T_A = 25^\circ\text{C}$, $V_{S+} = 5\text{ V}$, $V_{S-} = 0\text{ V}$, floating VO_{CM}, PD_X, and MODE pins, $V_{ICM} = \text{midsupply}$, D2D ac-coupled input/output configuration with $Z_S = 100\ \Omega$, $Z_L = 100\ \Omega$, external input resistor network (see Figure 8-3), ambient temperatures shown, and resistor network included as part of DUT characteristic plots (unless otherwise noted)

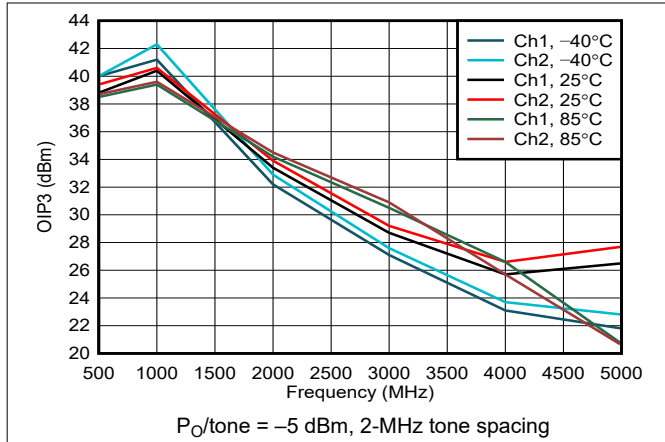

Figure 6-7. OIP3 Across Temperature

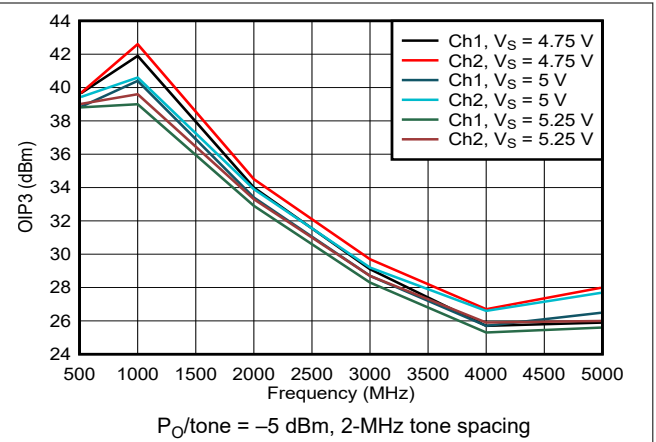

Figure 6-8. OIP3 Across Supply Voltage

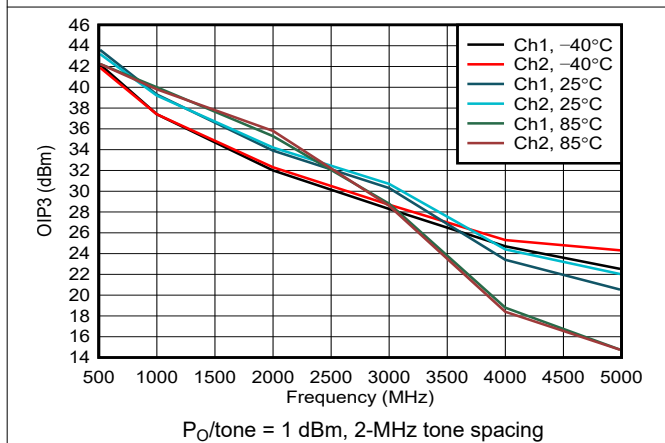

Figure 6-9. OIP3 Across Temperature

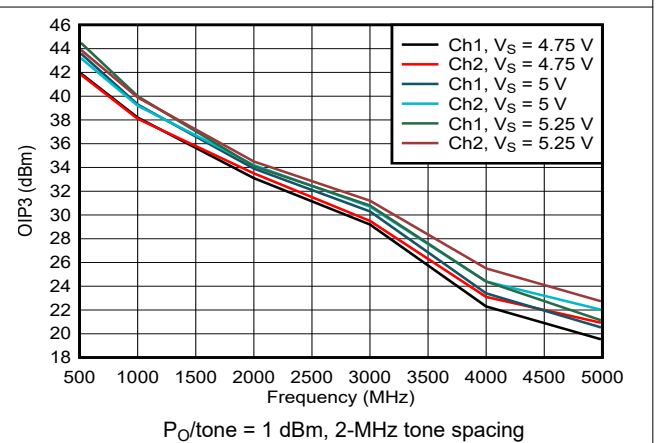

Figure 6-10. OIP3 Across Supply Voltage

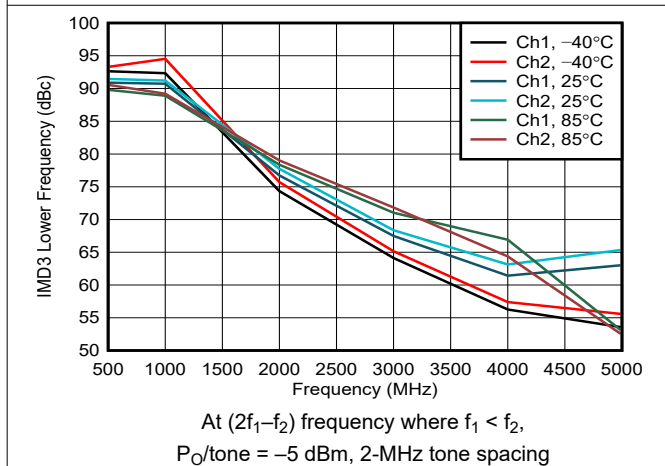

Figure 6-11. IMD3 Lower Across Temperature

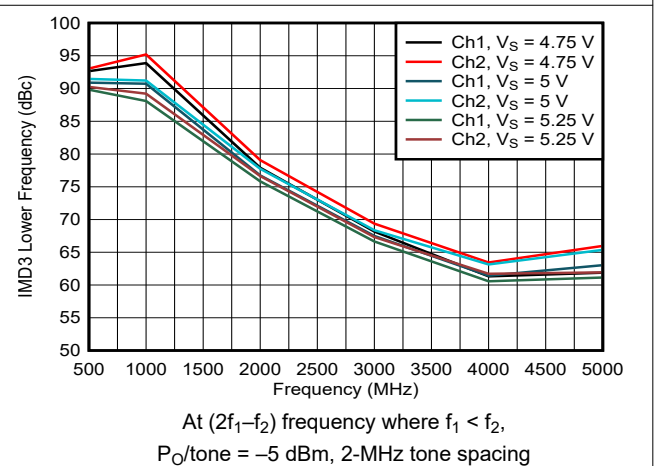
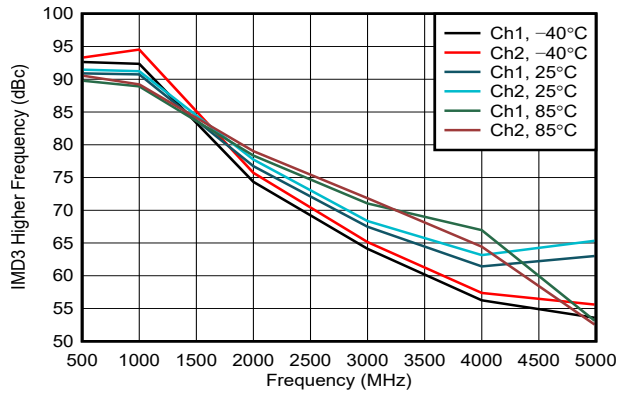

Figure 6-12. IMD3 Lower Across Supply Voltage

6.6 Typical Characteristics - TRF1305B2 (continued)

at $T_A = 25^\circ\text{C}$, $V_{S+} = 5\text{ V}$, $V_{S-} = 0\text{ V}$, floating VO_{CM}, PD_x, and MODE pins, $V_{ICM} = \text{midsupply}$, D2D ac-coupled input/output configuration with $Z_S = 100\ \Omega$, $Z_L = 100\ \Omega$, external input resistor network (see Figure 8-3), ambient temperatures shown, and resistor network included as part of DUT characteristic plots (unless otherwise noted)



At $(2f_2 - f_1)$ frequency where $f_1 < f_2$,
 $P_{O}/\text{tone} = -5\text{ dBm}$, 2-MHz tone spacing

Figure 6-13. IMD3 Higher Across Temperature

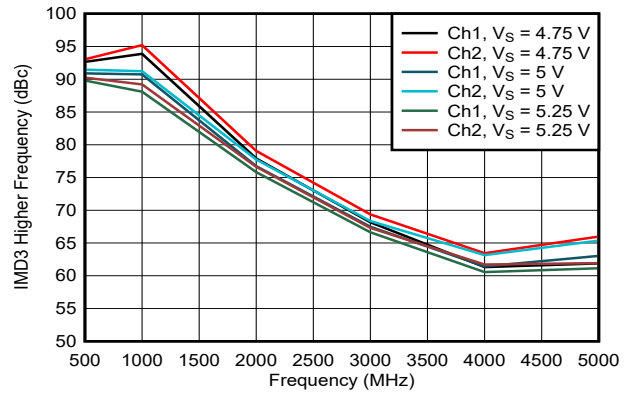

At $(2f_2 - f_1)$ frequency where $f_1 < f_2$,
 $P_{O}/\text{tone} = -5\text{ dBm}$, 2-MHz tone spacing

Figure 6-14. IMD3 Higher Across Supply Voltage

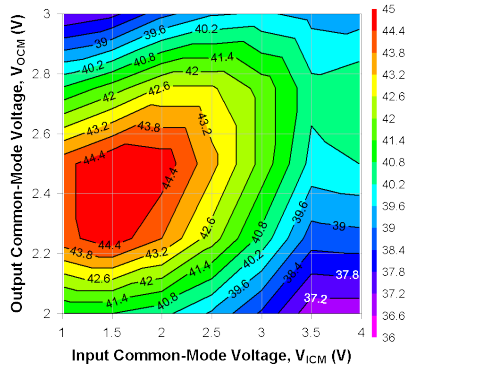

$P_{O}/\text{tone} = 1\text{ dBm}$, 2-MHz tone spacing,
 dc-coupled inputs with V_{ICM} forced through bias tees

Figure 6-15. OIP3 Across V_{ICM} and V_{OCM} at 500 MHz

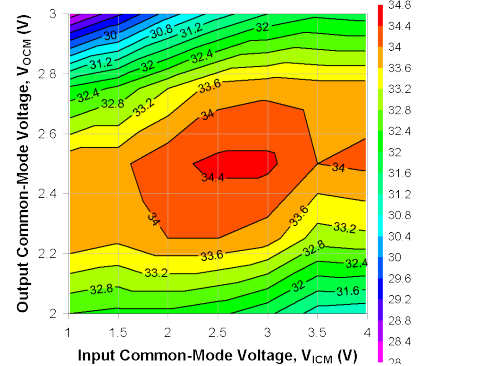

$P_{O}/\text{tone} = 1\text{ dBm}$, 2-MHz tone spacing,
 dc-coupled inputs with V_{ICM} forced through bias tees

Figure 6-16. OIP3 Across V_{ICM} and V_{OCM} at 2 GHz

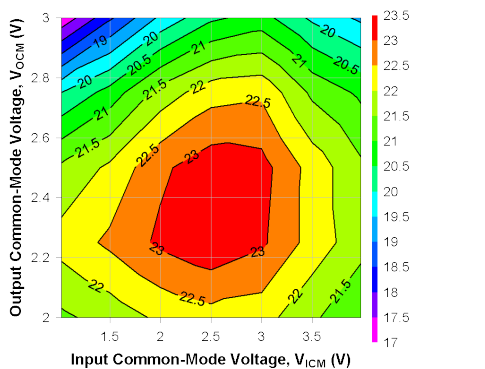

$P_{O}/\text{tone} = 1\text{ dBm}$, 2-MHz tone spacing,
 dc-coupled inputs with V_{ICM} forced through bias tees

Figure 6-17. OIP3 Across V_{ICM} and V_{OCM} at 4 GHz

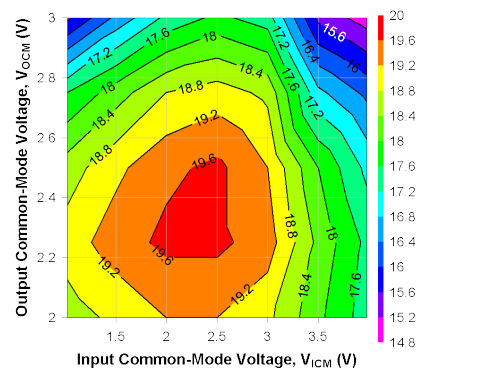

$P_{O}/\text{tone} = 1\text{ dBm}$, 2-MHz tone spacing,
 dc-coupled inputs with V_{ICM} forced through bias tees

Figure 6-18. OIP3 Across V_{ICM} and V_{OCM} at 5 GHz

6.6 Typical Characteristics - TRF1305B2 (continued)

at $T_A = 25^\circ\text{C}$, $V_{S+} = 5\text{ V}$, $V_{S-} = 0\text{ V}$, floating VO_{CM}, PD_x, and MODE pins, $V_{ICM} = \text{midsupply}$, D2D ac-coupled input/output configuration with $Z_S = 100\ \Omega$, $Z_L = 100\ \Omega$, external input resistor network (see Figure 8-3), ambient temperatures shown, and resistor network included as part of DUT characteristic plots (unless otherwise noted)

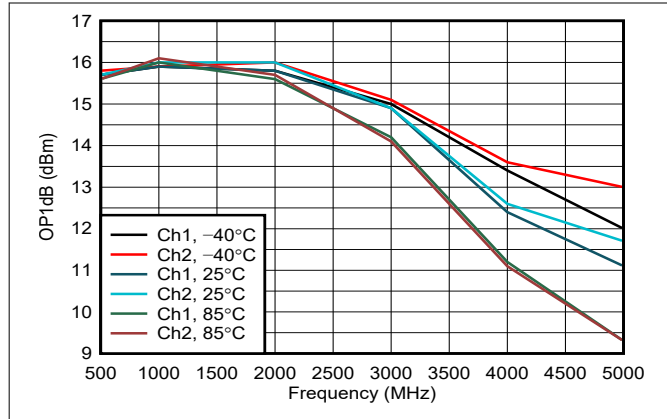

Figure 6-19. OP1dB Across Temperature

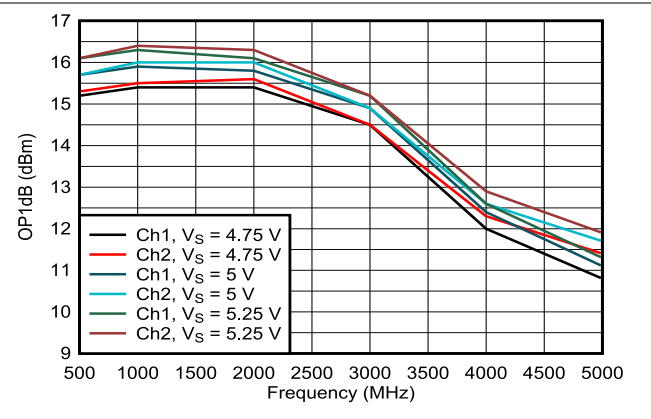

Figure 6-20. OP1dB Across Supply Voltage

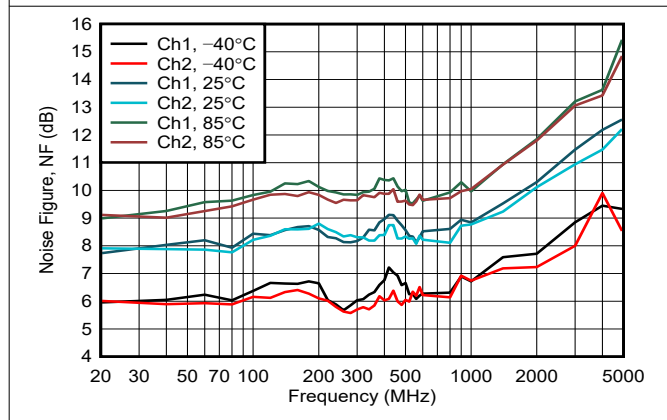

Figure 6-21. Noise Figure Across Temperature

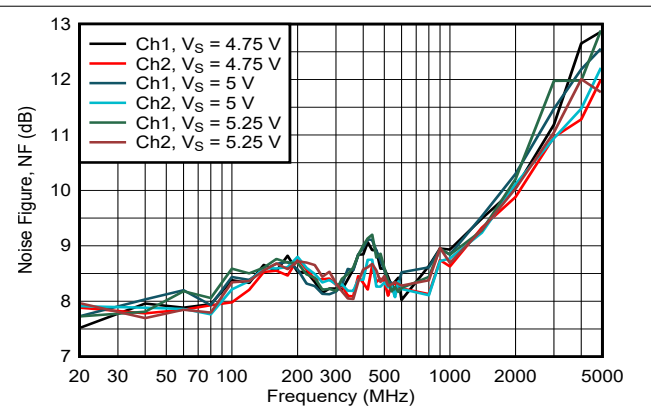

Figure 6-22. Noise Figure Across Supply Voltage

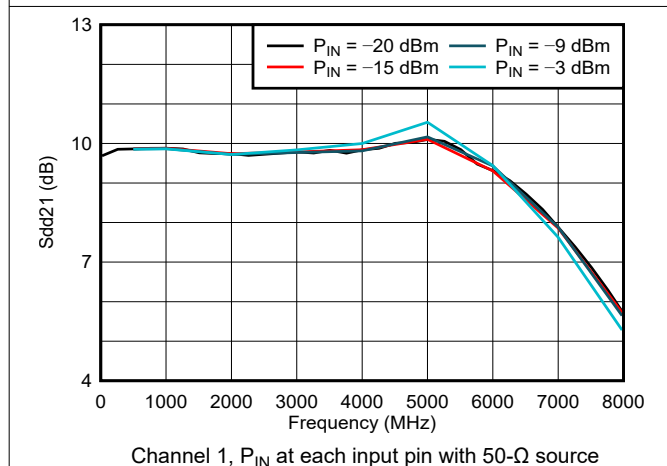

Figure 6-23. Power Gain (S21) Across Input Power Levels

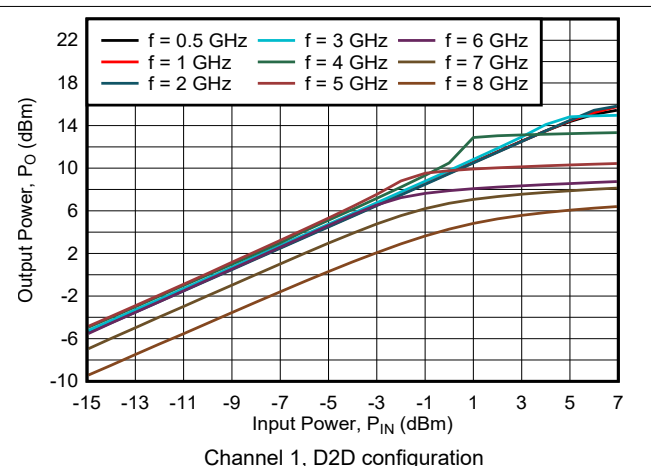
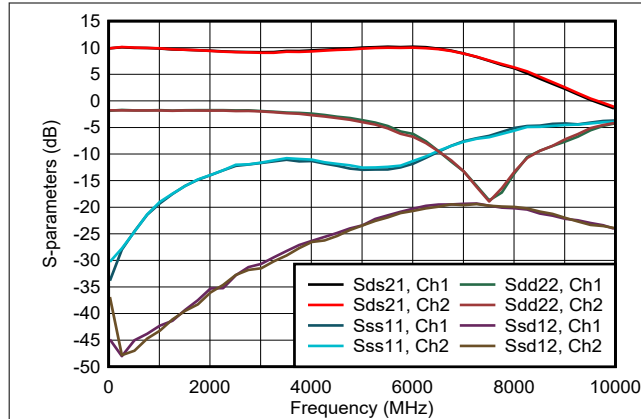

Figure 6-24. Input Power vs. Output Power

6.6 Typical Characteristics - TRF1305B2 (continued)

at $T_A = 25^\circ\text{C}$, $V_{S+} = 5\text{ V}$, $V_{S-} = 0\text{ V}$, floating VO_{CM}, PD_x, and MODE pins, $V_{ICM} = \text{midsupply}$, D2D ac-coupled input/output configuration with $Z_S = 100\ \Omega$, $Z_L = 100\ \Omega$, external input resistor network (see Figure 8-3), ambient temperatures shown, and resistor network included as part of DUT characteristic plots (unless otherwise noted)



S2D, $P_{IN} = -20\text{ dBm}$ at each input pin with 50- Ω source

Figure 6-25. S-Parameters in S2D Configuration

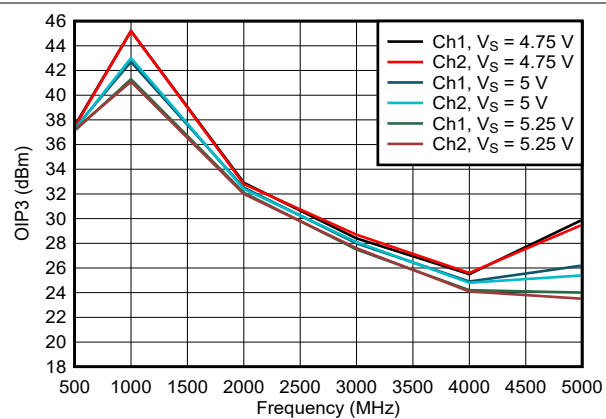

S2D, $P_{O}/\text{tone} = -5\text{ dBm}$, 2-MHz tone spacing

Figure 6-26. OIP3 Across Supply Voltage in S2D Configuration

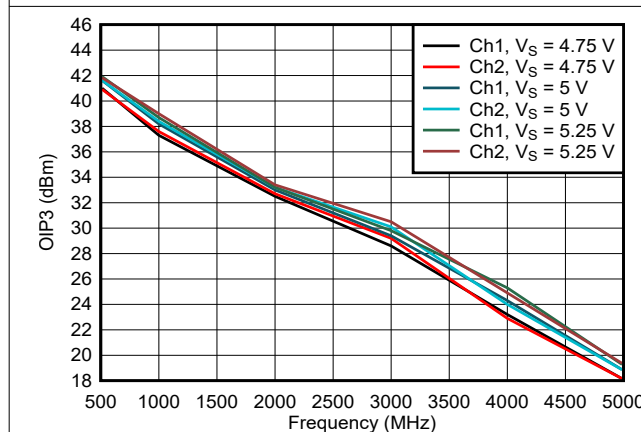

S2D configuration, $P_{O}/\text{tone} = 1\text{ dBm}$, 2-MHz tone spacing

Figure 6-27. OIP3 Across Supply Voltage

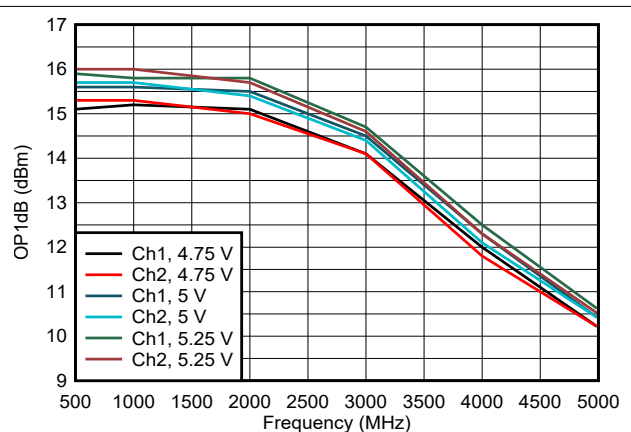

S2D configuration

Figure 6-28. OP1dB Across Supply Voltage

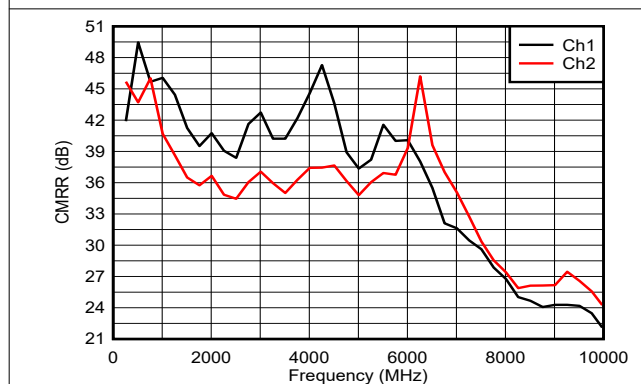

S2D, $P_{IN} = -20\text{ dBm}$ at each input pin with 50- Ω source

Figure 6-29. CMRR in S2D Configuration

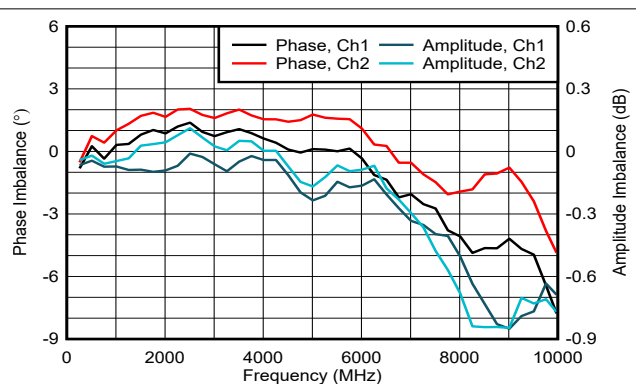

S2D, $P_{IN} = -20\text{ dBm}$ at each input pin with 50- Ω source

Figure 6-30. Gain and Phase Imbalance in S2D Configuration

6.6 Typical Characteristics - TRF1305B2 (continued)

at $T_A = 25^\circ\text{C}$, $V_{S+} = 5\text{ V}$, $V_{S-} = 0\text{ V}$, floating V_{OCM}, P_{Dx}, and MODE pins, $V_{ICM} = \text{midsupply}$, D2D ac-coupled input/output configuration with $Z_S = 100\ \Omega$, $Z_L = 100\ \Omega$, external input resistor network (see Figure 8-3), ambient temperatures shown, and resistor network included as part of DUT characteristic plots (unless otherwise noted)

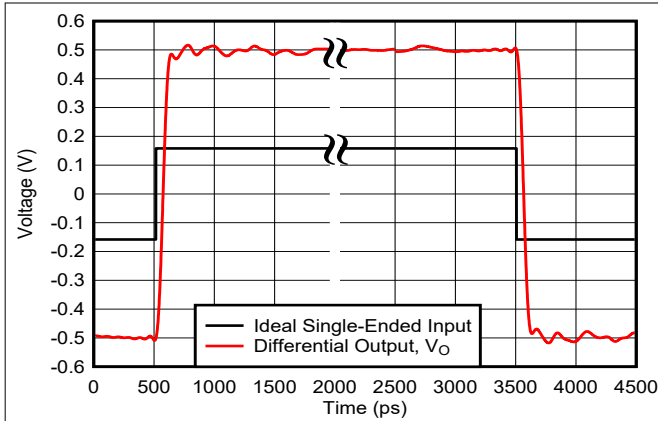

S2D configuration, $V_{S+} = 2.5\text{ V}$, $V_{S-} = -2.5\text{ V}$

Figure 6-31. Step Response

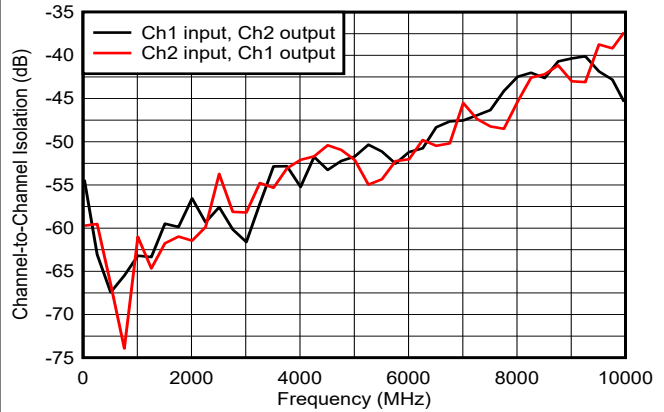

$P_{IN} = -20\text{ dBm}$ at each input pin with $50\text{-}\Omega$ source

Figure 6-32. Channel-to-Channel Isolation

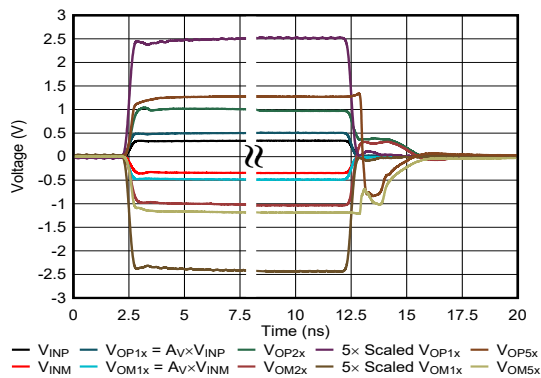

Voltage gain (A_V) $\approx 1.5\text{ V/V}$,

$V_{OZYx} = Y \times V_{OP1x}$, where $Z = \text{P or M}$ and $Y = 2\text{ or }5$

Figure 6-33. Overload Recovery Response and Timing

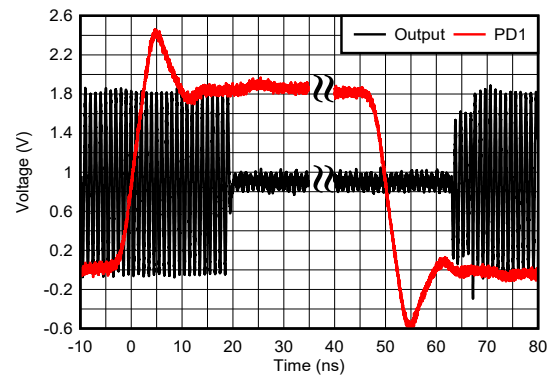

S2D configuration

Figure 6-34. Power Up and Power Down Timing

7 Detailed Description

7.1 Overview

The TRF1305A2 TRF1305B2 TRF1305C2 (TRF1305x2) devices are dual-channel, high-performance fully differential amplifiers optimized for very wideband signals from dc to > 6.5 GHz. This device family is primarily designed to interface with high-speed and RF data converters that often require differential input (ADCs) and output (DACs) signaling. The TRF1305x2 can be dc or ac coupled, and configured as single-ended input and differential output (S2D) or differential input and differential output (D2D). The devices feature an output common-mode pin (V_{OCM}) that allows the flexibility to set a desired common-mode output voltage. The V_{OCM} pin sets the same output common-mode voltage for both shared channels. The amplifier allows the data converters to interface with a dc-coupled IQ demodulator or modulator if used in a direct conversion system. The TRF1305x2 family comes in three preset power gain variants (15 dB, 10 dB, and 5 dB), and has a closed-loop feedback-amplifier architecture.

The devices are powered using two-rail supplies with a typical differential voltage of 5 V between the positive and negative supplies, and usable in split- or single-supply configurations. A power-down feature is also available that allows each amplifier channel to be powered down individually.

The output of the amplifiers is low impedance. Appropriate external series termination can be used to match to an arbitrary impedance.

7.2 Functional Block Diagram

This section shows the functional block diagram of the dual-channel TRF1305x2. The output common-mode control pin is common for both channels.

There are certain common internal circuits that are powered by both VS1+ and VS2+. Therefore, short both VS1+ and VS2+ on the board and supply both with a voltage even if only one channel is used. The negative supply, V_{S-}, is shared by both the channels.

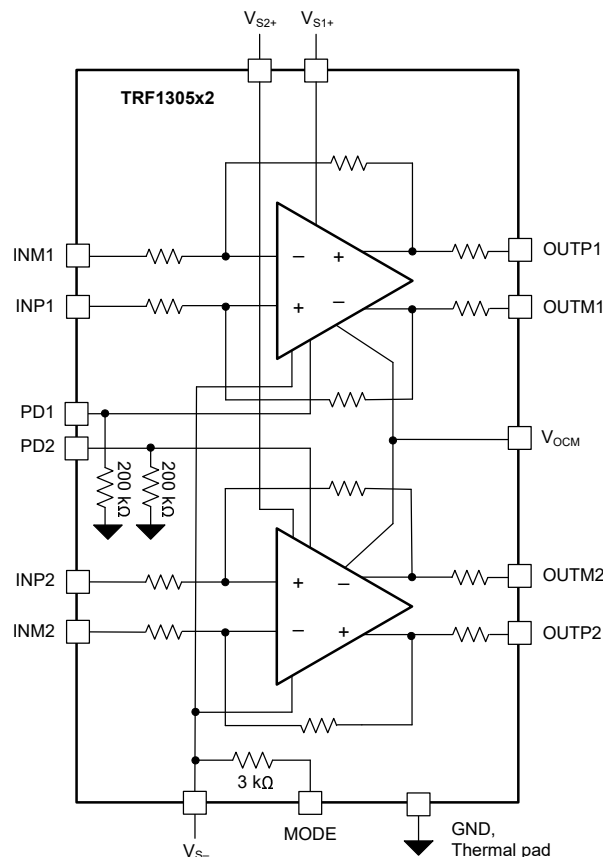

7.3 Feature Description

The TRF1305x2 includes the following key features:

- Two-rail floating supply with supply-independent thermal pads
 - Connect thermal pads to V_{S-} or GND
 - For best performance in the S2D configuration, connect the thermal pads to V_{S-}
 - RF signals and PDx pins referenced to thermal pads
- Single-supply or split-supply operation
- Supports single-ended and differential input configurations
- Performance-optimized preset fixed-gain variants
- Output common-mode control
- Input common-mode range selection by pullup resistor
- MODE pin: V_{ICM} range extension closer to V_{S+} or V_{S-} modes
- Digital-logic-controllable power-down option

7.3.1 Fully Differential Amplifier

The TRF1305x2 is a voltage-feedback fully differential amplifier (FDA) with wide bandwidth. The amplifier is designed for a differential power gain of 15 dB, 10 dB, or 5 dB depending on the device variant. This amplifier has excellent time-domain specifications with high slew rate, high input and output common-mode ranges, and fast transient settling time.

The output average voltage (common-mode) of the FDA device is controlled by a separate common-mode loop. The target output common-mode voltage is set by the VO_{CM} input pin.

7.3.2 Output Common-Mode Control

Figure 7-1 shows a functional diagram of the output common-mode control. Internally the VO_{CM} pin sees an LDO output voltage that is equal to $V_{S-} + 2.5$ V connected through a 2.5-k Ω resistor.

Floating the VO_{CM} pin is allowed. The output common-mode voltage at the output pins, OUTP_x and OUTM_x, defaults to the LDO output voltage of $V_{S-} + 2.5$ V when VO_{CM} pin is floated. Floating the VO_{CM} pin results in a V_{OCM} voltage equal to midsupply when $V_S = 5$ V. If the VO_{CM} pin is driven, then drive the pin from a low-impedance source. Limit the value of R_{OCM} to less than 25 Ω for accurate reflection of the forced V_{OCM} voltage at the device outputs.

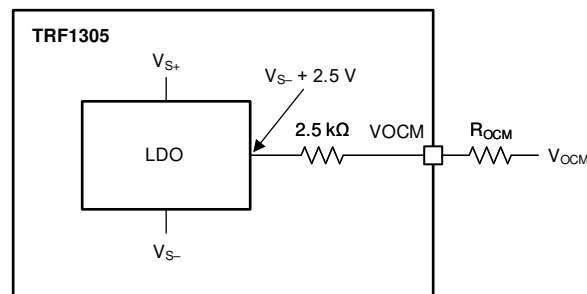

Figure 7-1. Output Common-Mode Control

7.3.3 Internal Resistor Configuration

Figure 7-2 shows the internal resistor configurations of TRF1305x2. Table 7-1 provides the values of these resistors for different gain variants.

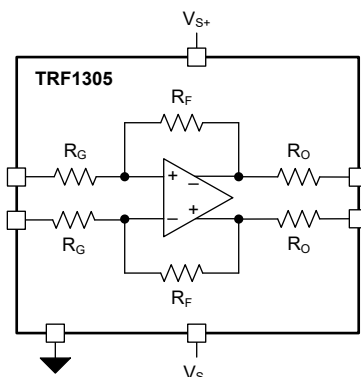

Figure 7-2. TRF1305x2 Internal Resistor Configuration

Table 7-1. Resistor Values

DEVICE NAME	GAIN (dB)	R _G (Ω)	R _F (Ω)	R _O (Ω)
TRF1305A2	15	6.25	258	4
TRF1305B2	10	12.5	161	4
TRF1305C2	5	17	97	4

7.4 Device Functional Modes

7.4.1 MODE Pin

The TRF1305x2 have additional useful features that can be configured using the MODE pin. To select the device mode, either connect a $\pm 2\%$ maximum tolerance pullup resistor between the MODE pin and VS2+, or force a voltage on the MODE pin. Internally, the MODE pin is referenced to V_{S-} through a 3-kΩ resistor (see Section 7.2). The selected mode applies to both channels.

Table 7-2 provides the value of the pullup resistor for each mode, the expected voltage, V_{MODE}, at the MODE pin when the pullup resistor is used or the necessary V_{MODE} voltage to set the device mode, and the mode configurations. The V_{MODE} voltage thresholds are approximately midway between the adjacent modes typical V_{MODE} voltage. If the mode functionality is used, use a decoupling capacitor on the MODE pin.

Table 7-2. MODE Pin Configuration

MODE NUMBER	TRF1305x2: PULLUP RESISTOR TO VS2+ ($\pm 2\%$ MAXIMUM TOLERANCE)	MODE PIN VOLTAGE, V _{MODE} (V)	V _{ICM} RANGE EXTENSION ⁽¹⁾
0	OPEN	V _{S-}	Default V _{ICM} range
1	25.6 kΩ	V _{S-} + 0.5 V	Low side, extends V _{ICM} range closer to V _{S-}
2	12.8 kΩ	V _{S-} + 0.95 V	High side, extends V _{ICM} range closer to V _{S+}
N/A	Do not use pullup resistor < 10 kΩ or set V _{MODE} > V _{S-} + 1.15 V		

To switch the mode without turning the supplies off, use a switch or MUX connected between the pullup resistor options and VS2+, or force a mode-appropriate V_{MODE} voltage. However, powering down the device using the power-down feature between mode changes is preferred. The low-side and high-side V_{ICM} range extension modes source and sink currents, respectively (see also Section 7.4.1.1). Ensure that the external circuitry is ready to sink or source these currents before the device is put in the active mode from the powered-down state.

7.4.1.1 Input Common-Mode Extension

The TRF1305x2 supports a V_{ICM} voltage closer to either V_{S+} or V_{S-} voltage than the default specified input common-mode range in [Section 6.5](#), when configured in one of the V_{ICM} extension modes. The V_{ICM} extension mode can only be used in D2D configuration.

When configured in the low-side V_{ICM} extension mode, TRF1305B2 supports a 450 mV lower input common-mode voltage than the default option. For example, the lower limit of V_{ICM} voltage range extends from a default value of $V_{S-} + 1.5$ V to $V_{S-} + 1.05$ V for the TRF1305B2 variant, and the higher limit also shifts lower from a default value of $V_{S-} + 3.5$ V to $V_{S-} + 3.05$ V. At the lowest V_{ICM} voltage, approximately 15 mA current must be sunk by the external circuitry connected to the INPx and INMx pins.

When configured in the high-side V_{ICM} extension mode, TRF1305B2 supports a 450 mV higher input common-mode voltage than the default option. For example, the higher limit of V_{ICM} voltage range extends from a default value of $V_{S-} + 3.5$ V to $V_{S-} + 3.95$ V for the TRF1305B2 variant, and the lower limit also shifts up from a default of $V_{S-} + 1.5$ V to $V_{S-} + 1.95$ V. At the highest V_{ICM} voltage, approximately 15 mA current must be sourced by the external circuitry connected to the INPx and INMx pins.

Either resistors connected to supplies or external current sources can be used to sink or source the currents flowing out or into to the INPx and INMx pins during the low-side or high-side V_{ICM} extension modes, respectively.

7.4.2 Power-Down Mode

The TRF1305x2 have two bias modes, active and power-down, that are controlled by the voltage on the PD pin. The PD pin is referenced to thermal pad through a 200-k Ω resistor; see also [Section 7.2](#). If the $V_{S+} \geq 3.3$ V configuration is used, ensure that the PD voltage does not exceed the [Absolute Maximum Ratings](#) in case the high PD voltage is derived from V_{S+} .

With PD1 and PD2, control each channel independently, and individually power down each channel. Both 1.8-V and 3.3-V digital logic is supported for power down control.

8 Application and Implementation

Note

Information in the following applications sections is not part of the TI component specification, and TI does not warrant its accuracy or completeness. TI's customers are responsible for determining suitability of components for their purposes, as well as validating and testing their design implementation to confirm system functionality.

8.1 Application Information

8.1.1 Input and Output Interface Considerations

8.1.1.1 Single-Ended Input

In the single-ended input configuration, one of the amplifier input pins is driven from a source while the other input is terminated with an external resistor. [Figure 8-1](#) shows an ac-coupled, single-ended input configuration driven from and matched to a 50-Ω source. [Figure 8-1](#) shows how the non-driven INM pin is terminated with a 50-Ω external resistor to match to a source with the same 50-Ω impedance at the INP pin. The shown configuration works for all gain versions of TRF1305x2.

To configure the design in [Figure 8-1](#) for single-ended, dc-coupled input, replace the ac-coupling capacitors with shorts, and externally bias both INP and INM pins to a voltage close to the mid-supply or within the common-mode limits of the amplifier.

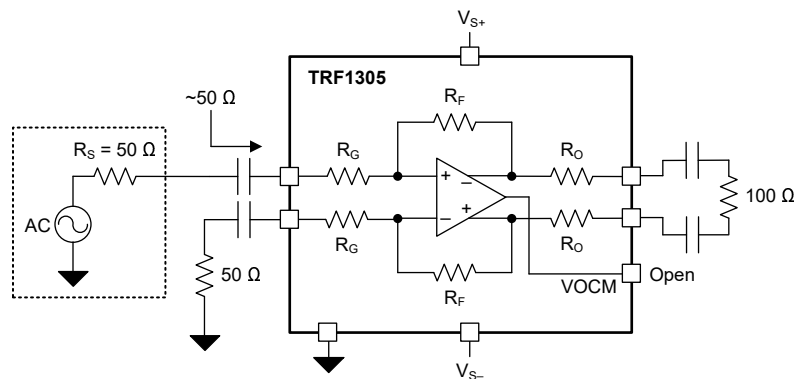

Figure 8-1. AC-Coupled, Single-Ended Input Matched to a 50 Ω Source

8.1.1.2 Differential Input

[Figure 8-2](#) shows how a simple network consisting of three resistors is used to match the differential input to a 100-Ω differential source. Though the 1-kΩ shunt resistor, R_{IN_SH} , does not have any impact at dc to low frequencies, the resistor is necessary to get the full wideband performance from TRF1305x2. [Figure 8-3](#) shows the configuration for ac-coupled differential input designs. The resistors values shown in [Figure 8-2](#) and [Figure 8-3](#) work for all gain versions of the TRF1305x2 for an 100-Ω input match to a 100-Ω differential source.

Use small foot-print resistors (0201 preferred), and RF quality for high frequency matching.

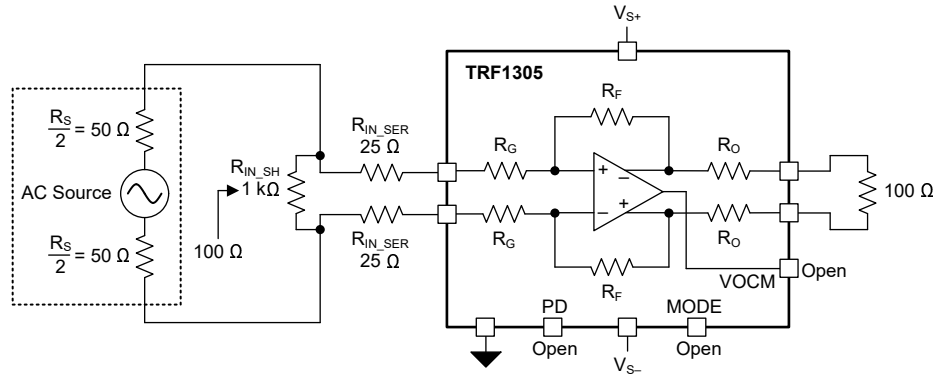

Figure 8-2. DC-Coupled Differential Input Matched to a 100-Ω Differential Source

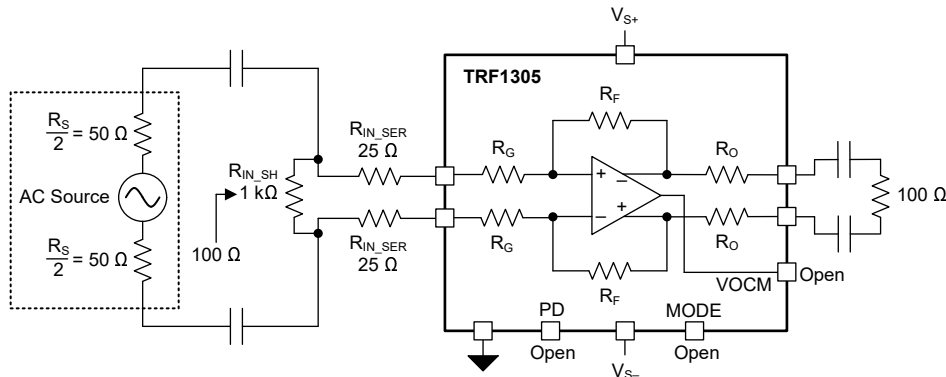

Figure 8-3. AC-Coupled Differential Input Matched to a 100-Ω Differential Source

8.1.1.3 DC Coupling Considerations

The TRF1305x2 accepts a wide range of input dc common-mode (CM) voltages. Take into consideration the dc current loading of the source when the TRF1305x2 is dc-coupled at the input. Figure 8-4 shows that when the input CM voltage, V_{ICM} , is different than the output CM voltage, V_{OCM} , a net dc current flow from or to the source occurs. Equation 1 shows the relationship that the source or sink current, I_{CM} , has with the input and output CM voltages:

$$I_{CM} = \frac{(V_{OCM} - V_{ICM})}{(R_F + R_G)} \quad (1)$$

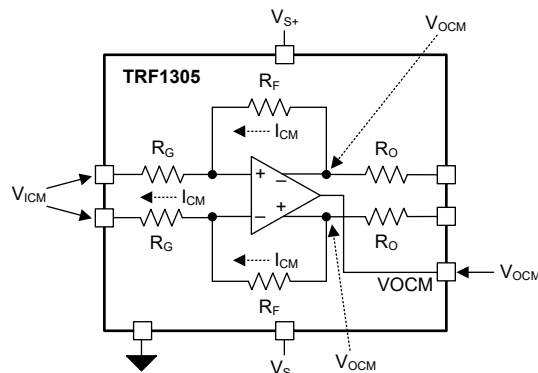

Figure 8-4. Net DC Current Flow When Input and Output Common-Mode Voltages are not Equal

8.1.2 Gain Adjustment With External Resistors in a Differential Input Configuration

The TRF1305x2 allow minor gain adjustments by configuring the input external resistive network that is part of the differential input configuration. Figure 8-5 shows the external input network that comprises of a shunt resistor, R_{IN_SH} , and two series input resistors, R_{IN_SER} , connected to the input pins of the amplifier.

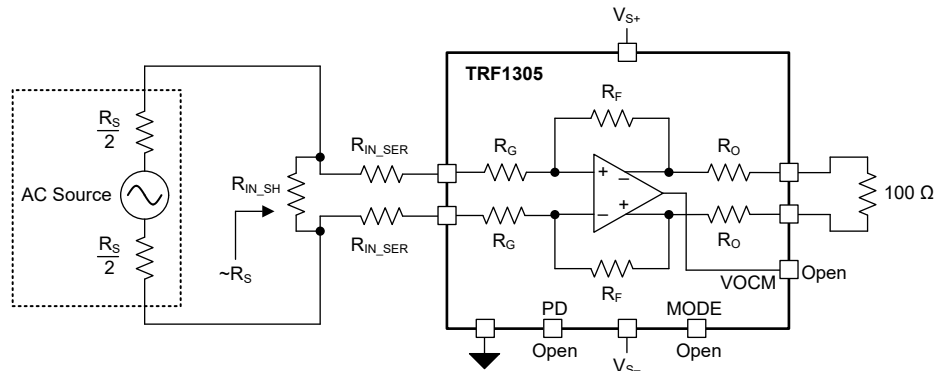

Figure 8-5. Gain Adjustment With External Resistor Network

Table 8-1 provides resistor configurations for a 100- Ω differential source impedance.

Table 8-1. Resistor Table for $R_S = 100 \Omega$

TRF1305B2		
POWER GAIN (dB)	R_{IN_SH} (Ω)	R_{IN_SER} (Ω)
10	1000	25
9	408	30
8	267	35
7	204	41
6	169	47
5	146	54

Use external resistive attenuation network only for small gain adjustments because there is a dB-to-dB noise figure degradation with the resistive attenuators. Use an amplifier version that requires minimal attenuation for achieving the overall gain.

For example, to realize 10-dB overall gain with $R_S = 100\text{-}\Omega$ differential, the two options are:

1. TRF1305B2 with $R_{IN_SH} = 1000 \Omega$ and $R_{IN_SER} = 25\text{-}\Omega$ resistors
2. TRF1305A2 with $R_{IN_SH} = 125 \Omega$ and $R_{IN_SER} = 49\text{-}\Omega$ resistors

Option 1 is recommended because the NF is better by approximately 3 dB compared to option 2.

8.2 Typical Application

8.2.1 TRF1305x2 as ADC Driver in a Zero-IF Receiver

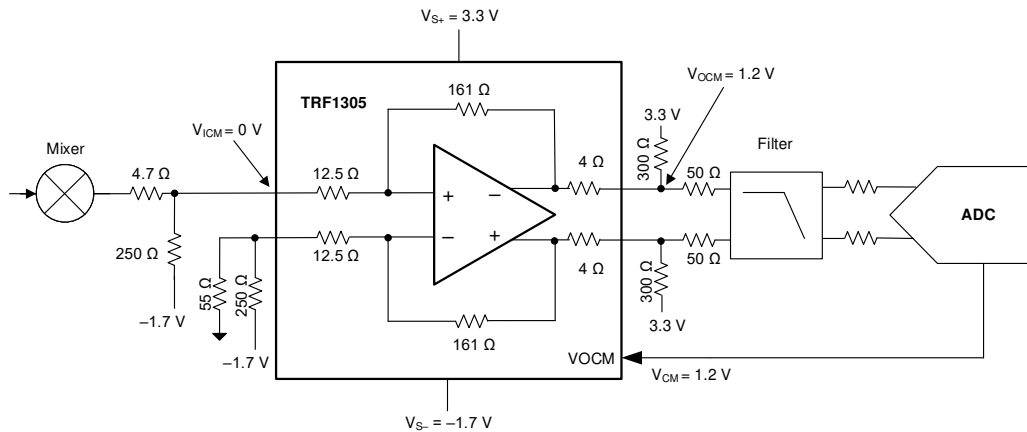

Figure 8-6. TRF1305x2 as ADC Driver in a Zero-IF Receiver

Consider a zero-IF (direct down conversion) application in which an IQ demodulator is interfaced to a pair of ADCs. The TRF1305x2 is used here as an interface amplifier between the demodulator and the ADCs. The dc common-mode of the demodulator output and ADC input are different. The TRF1305x2 dc couples the demodulator to ADC without degrading the signal integrity of the signal chain.

8.2.1.1 Design Requirements

The primary design requirement for an IQ demodulator application is to interface a pair of passive mixers with an RF ADC. The mixers have a 0-V common-mode voltage. The ADC requires an input common-mode voltage of 1.2 V with full-scale swing of 1.35 V_{PP}. Choose the power supplies, and design the input/output network for the TRF1305x2 as the ADC driver amplifier, to perform the dc level shifting and amplification function.

8.2.1.2 Detailed Design Procedure

The first step is to choose the TRF1305x2 supplies. Ensure that the midsupply voltage, V_{MIDSUPPLY}, is between the ADC common-mode (CM) voltage and the mixer CM voltage. V_{MIDSUPPLY} is typically positioned closer to the ADC CM because the output CM range of the amplifier is less than the input CM range. Ensure that the dc of the signal at the input and output of the amplifier are within the valid operating common-mode voltage range. Use the MODE pin for cases where an extended range of the input CM is required.

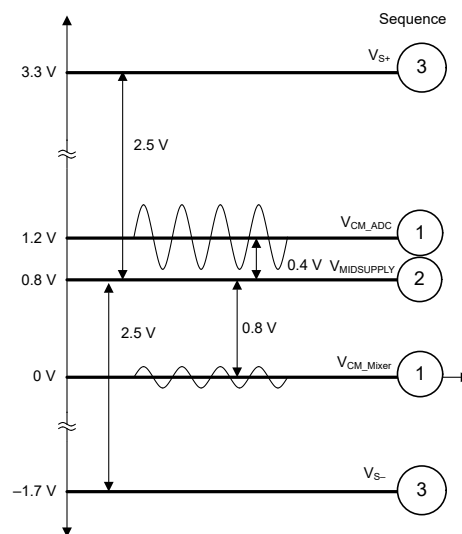

Figure 8-7. Choosing Supply Voltages with Given Common-Mode Voltages

Figure 8-7 shows how $V_{MIDSUPPLY}$ is chosen to be 0.8 V, so that the amplifier input has a CM offset from $V_{MIDSUPPLY}$ of 0.8 V and output has a CM offset from $V_{MIDSUPPLY}$ of 0.4 V ($1.2\text{ V} - 0.8\text{ V}$). The CM offsets are within the valid common-mode range of the amplifier, so the supplies of the TRF1305B2 are chosen to be $V_{S+} = 3.3\text{ V}$ ($0.8\text{ V} + 2.5\text{ V}$) and $V_{S-} = -1.7\text{ V}$ ($0.8\text{ V} - 2.5\text{ V}$). Further optimization in the choice of supply is possible by selecting the input and output CM voltages for the best OIP3 performance. Section 8.2.1.3 has contour graphs that show OIP3 across input and output common-mode voltages.

The output CM is greater than the input CM; therefore, a net 6.9-mA ($(1.2\text{ V} - 0\text{ V}) / (161\ \Omega + 12.5\ \Omega)$) dc current flows from the output to input through the internal feedback resistors. Depending on the choice of the passive mixer, this current can required to be sunk outside the mixer so that the bias conditions of the mixer are not disturbed. A 250- Ω pulldown resistor connected to the INP pin to -1.7 V supply is adequate. If the 6.9-mA dc current is sourced entirely from the amplifier, then the output headroom can be affected. Therefore, source the current externally from the supply using a pair of pullup resistors connected to the amplifier outputs. 300- Ω pullup resistors from OUTP and OUTM to 3.3 V are adequate.

The I-channel mixer output has a 50- Ω port and is connected to the amplifier INP pin through a small (4.7 Ω) series resistor. The INM pin is terminated to ground through a 55- Ω resistor and to -1.7 V through a 250- Ω resistor. This configuration makes sure that the impedance the amplifier sees at the input pins is the same at both INP and INM pins. The impedance of the mixer is close to 43 Ω and provides better than a -20-dB return loss (theoretically). Be aware that there is some drop in the gain due to these resistor networks. Also, the values of the resistors chosen in Figure 8-6 are a good starting point; in practice, some adjustment is often needed to simultaneously meet the dc conditions and the RF performance.

At the amplifier output, 50- Ω series resistors are used to match to the antialiasing filter with 100- Ω differential input impedance. The filter output is connected to ADC with appropriate matching. Figure 8-6 only shows the I-channel; the Q-channel has an identical configuration.

8.2.1.3 Application Curves

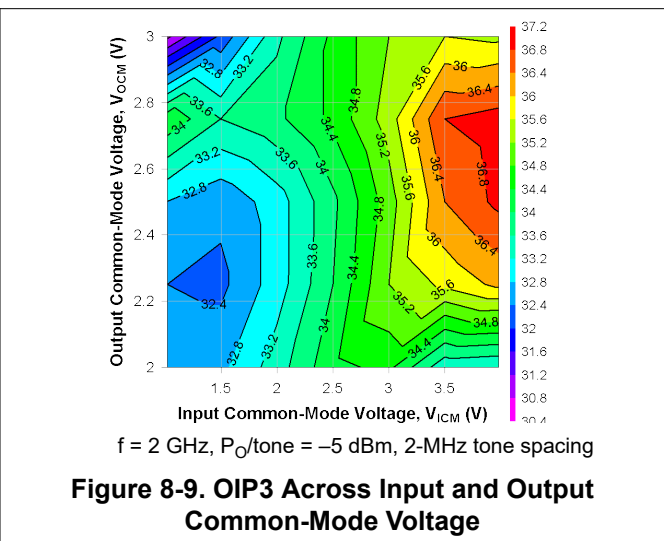
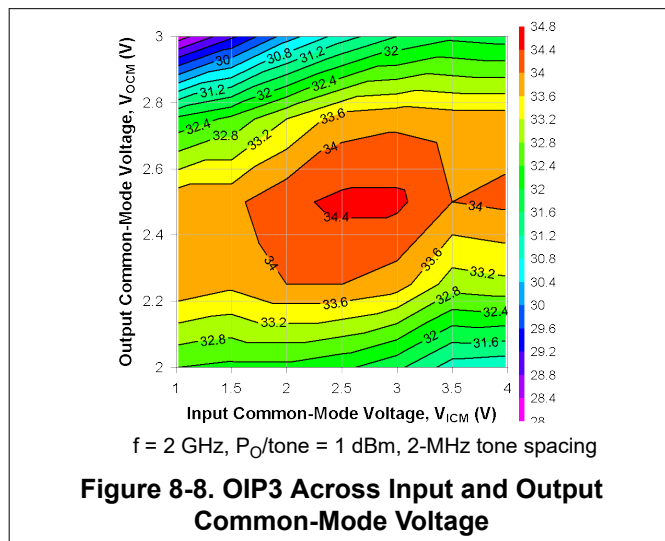

8.3 Power Supply Recommendations

8.3.1 Supply Voltages

For the TRF1305x2, short both the VS1+ and VS2+ supply pins together to the same voltage for proper device operation. The typical differential supply between VS+ and VS– is 5 V. The VS+ and VS– supply pins can be floated with respect to the thermal pad within the specified range listed in [Section 6.1](#) and [Section 6.3](#).

8.3.2 Single-Supply Operation

The VS– pin is connected to GND in the single-supply configuration. Single-supply operation is most convenient in ac-coupled configurations because the dc common-mode voltages of the source at the inputs and the driven circuit at the outputs are inherently decoupled.

8.3.3 Split-Supply Operation

In split-supply configuration, choose the V_{S+} and V_{S-} voltages to be within the ranges specified in [Section 6.1](#) and [Section 6.3](#). The TRF1305x2 allows choosing negative voltages for the V_{S-} supply, thereby allowing the flexibility to choose input and output common-mode voltages according to the input network and output network requirements.

8.3.4 Supply Decoupling

The VS+ and VS– supply pins are decoupled individually to GND using external capacitors. For the TRF1305x2, VS+ decoupling can be split between VS1+ to GND and VS2+ to GND separately for ease of board layout. Place the decoupling capacitors close to the device supply pins.

8.4 Layout

8.4.1 Layout Guidelines

The TRF1305x2 devices are wideband closed-loop feedback amplifiers. When designing with wideband RF amplifiers that have high gain, take certain board layout precautions to maintain stability and optimized performance. Use a multilayer board to maintain signal integrity, power integrity, and thermal performance.

Route the RF input and output lines as grounded coplanar waveguide (GCPW) lines. Ground pins are the reference for the RF signals. Ensure that the second layer of the PCB has a continuous ground layer without any ground cutouts in the vicinity of the amplifier. To minimize phase imbalance, match the length of the output differential lines of both channels. Length matching the input traces is also important, especially if the input configuration is differential. Use small-footprint, passive components wherever possible.

For good heat dissipation, connect the device thermal pad to the board ground planes using thermal vias under the device. For improved heat dissipation, connect the device thermal pad to the top layer ground plane of the board.

8.4.1.1 Thermal Considerations

The TRF1305x2 are packaged in a WQFN-FCRLF package that has excellent thermal properties. Connect the thermal pads underneath the devices to the thermally dissipative ground plane on the board. For good thermal design, use thermal vias to connect the thermal pad plane on the top layer of the PCB to the ground planes in the inner layers.

Limit the total power dissipation to keep the device junction temperature less than 150°C for instantaneous power, and less than 125°C for continuous power.

8.4.2 Layout Example

Figure 8-10 shows an example layout for TRF1305x2 with a differential input configuration. Key areas are highlighted in the figure.

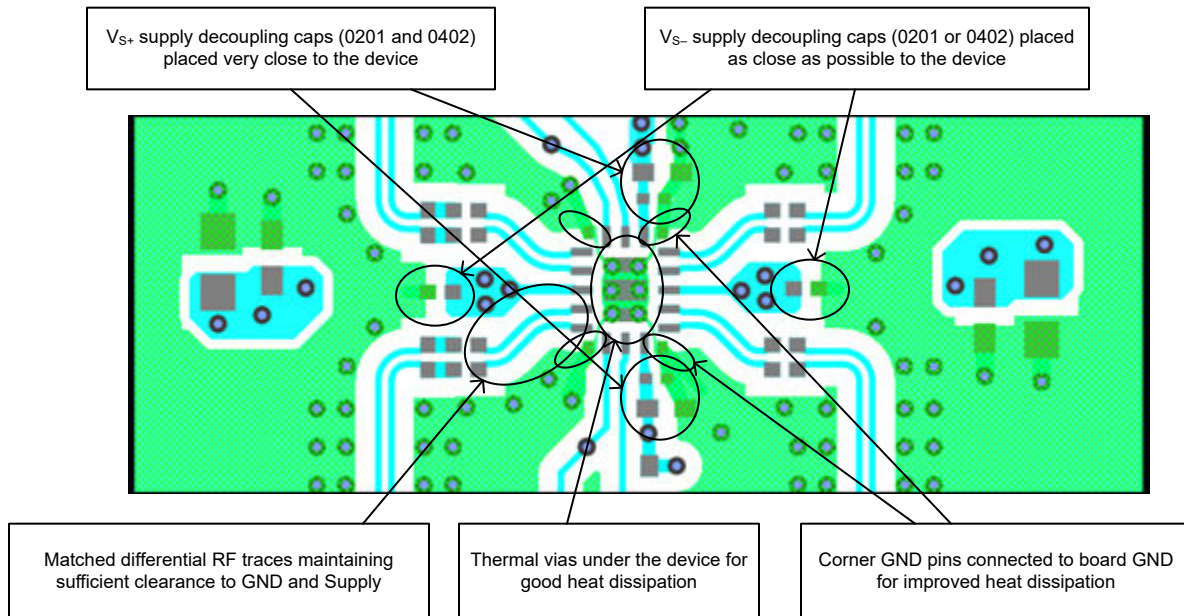

Figure 8-10. Layout Example: TRF1305x2 With Differential Input

The TRF1305x2 can be evaluated using EVM boards that can be ordered from the [TRF1305B2](#) product folder. For more information about the evaluation board construction and test setup, see the [TRF1305 EVM User's Guide](#).

9 Device and Documentation Support

9.1 Receiving Notification of Documentation Updates

To receive notification of documentation updates, navigate to the device product folder on ti.com. Click on *Notifications* to register and receive a weekly digest of any product information that has changed. For change details, review the revision history included in any revised document.

9.2 Support Resources

[TI E2E™ support forums](#) are an engineer's go-to source for fast, verified answers and design help — straight from the experts. Search existing answers or ask your own question to get the quick design help you need.

Linked content is provided "AS IS" by the respective contributors. They do not constitute TI specifications and do not necessarily reflect TI's views; see TI's [Terms of Use](#).

9.3 Trademarks

TI E2E™ is a trademark of Texas Instruments.
All trademarks are the property of their respective owners.

9.4 Electrostatic Discharge Caution



This integrated circuit can be damaged by ESD. Texas Instruments recommends that all integrated circuits be handled with appropriate precautions. Failure to observe proper handling and installation procedures can cause damage.

ESD damage can range from subtle performance degradation to complete device failure. Precision integrated circuits may be more susceptible to damage because very small parametric changes could cause the device not to meet its published specifications.

9.5 Glossary

[TI Glossary](#) This glossary lists and explains terms, acronyms, and definitions.

10 Revision History

DATE	REVISION	NOTES
December 2023	*	Initial Release

11 Mechanical, Packaging, and Orderable Information

The following pages include mechanical, packaging, and orderable information. This information is the most current data available for the designated devices. This data is subject to change without notice and revision of this document. For browser-based versions of this data sheet, refer to the left-hand navigation.

PACKAGING INFORMATION

Orderable part number	Status (1)	Material type (2)	Package Pins	Package qty Carrier	RoHS (3)	Lead finish/ Ball material (4)	MSL rating/ Peak reflow (5)	Op temp (°C)	Part marking (6)
TRF1305B2RYPR	Active	Production	VQFN-FCRLF (RYP) 16	2000 LARGE T&R	Yes	NIPDAU	Level-2-260C-1 YEAR	-40 to 105	1305B2
TRF1305B2RYPR.A	Active	Production	VQFN-FCRLF (RYP) 16	2000 LARGE T&R	Yes	NIPDAU	Level-2-260C-1 YEAR	-40 to 105	1305B2

(1) **Status:** For more details on status, see our [product life cycle](#).

(2) **Material type:** When designated, preproduction parts are prototypes/experimental devices, and are not yet approved or released for full production. Testing and final process, including without limitation quality assurance, reliability performance testing, and/or process qualification, may not yet be complete, and this item is subject to further changes or possible discontinuation. If available for ordering, purchases will be subject to an additional waiver at checkout, and are intended for early internal evaluation purposes only. These items are sold without warranties of any kind.

(3) **RoHS values:** Yes, No, RoHS Exempt. See the [TI RoHS Statement](#) for additional information and value definition.

(4) **Lead finish/Ball material:** Parts may have multiple material finish options. Finish options are separated by a vertical ruled line. Lead finish/Ball material values may wrap to two lines if the finish value exceeds the maximum column width.

(5) **MSL rating/Peak reflow:** The moisture sensitivity level ratings and peak solder (reflow) temperatures. In the event that a part has multiple moisture sensitivity ratings, only the lowest level per JEDEC standards is shown. Refer to the shipping label for the actual reflow temperature that will be used to mount the part to the printed circuit board.

(6) **Part marking:** There may be an additional marking, which relates to the logo, the lot trace code information, or the environmental category of the part.

Multiple part markings will be inside parentheses. Only one part marking contained in parentheses and separated by a "~" will appear on a part. If a line is indented then it is a continuation of the previous line and the two combined represent the entire part marking for that device.

Important Information and Disclaimer: The information provided on this page represents TI's knowledge and belief as of the date that it is provided. TI bases its knowledge and belief on information provided by third parties, and makes no representation or warranty as to the accuracy of such information. Efforts are underway to better integrate information from third parties. TI has taken and continues to take reasonable steps to provide representative and accurate information but may not have conducted destructive testing or chemical analysis on incoming materials and chemicals. TI and TI suppliers consider certain information to be proprietary, and thus CAS numbers and other limited information may not be available for release.

In no event shall TI's liability arising out of such information exceed the total purchase price of the TI part(s) at issue in this document sold by TI to Customer on an annual basis.

TAPE AND REEL INFORMATION

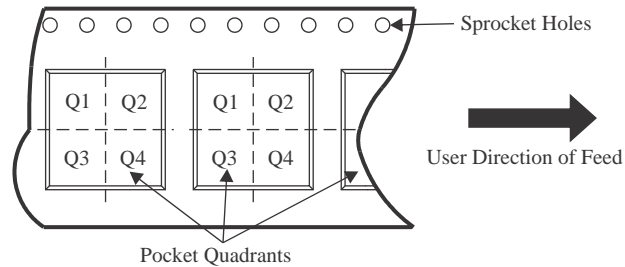
QUADRANT ASSIGNMENTS FOR PIN 1 ORIENTATION IN TAPE

*All dimensions are nominal

Device	Package Type	Package Drawing	Pins	SPQ	Reel Diameter (mm)	Reel Width W1 (mm)	A0 (mm)	B0 (mm)	K0 (mm)	P1 (mm)	W (mm)	Pin1 Quadrant
TRF1305B2RYPR	VQFN-FCRLF	RYP	16	2000	330.0	12.4	2.8	3.3	1.2	4.0	12.0	Q1

TAPE AND REEL BOX DIMENSIONS

*All dimensions are nominal

Device	Package Type	Package Drawing	Pins	SPQ	Length (mm)	Width (mm)	Height (mm)
TRF1305B2RYPR	VQFN-FCRLF	RYP	16	2000	338.0	355.0	50.0

EXAMPLE BOARD LAYOUT

RYP0016A

VQFN-FCRLF - 1.05 mm max height

PLASTIC QUAD FLATPACK - NO LEAD

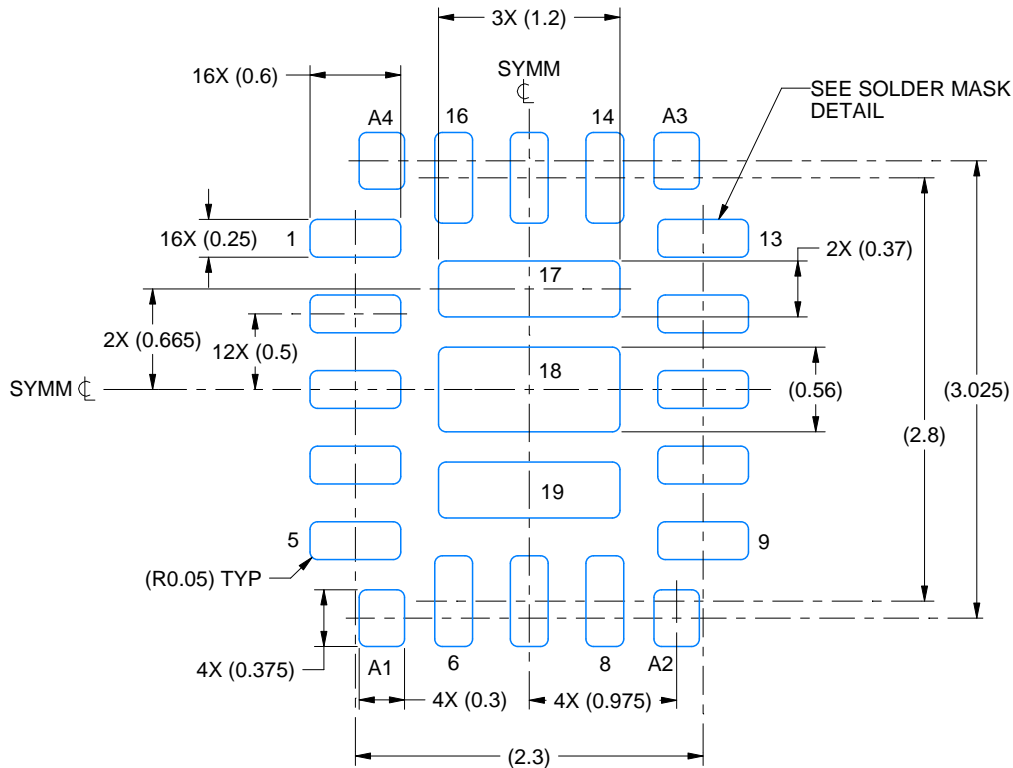

LAND PATTERN EXAMPLE
EXPOSED METAL SHOWN
SCALE: 20X

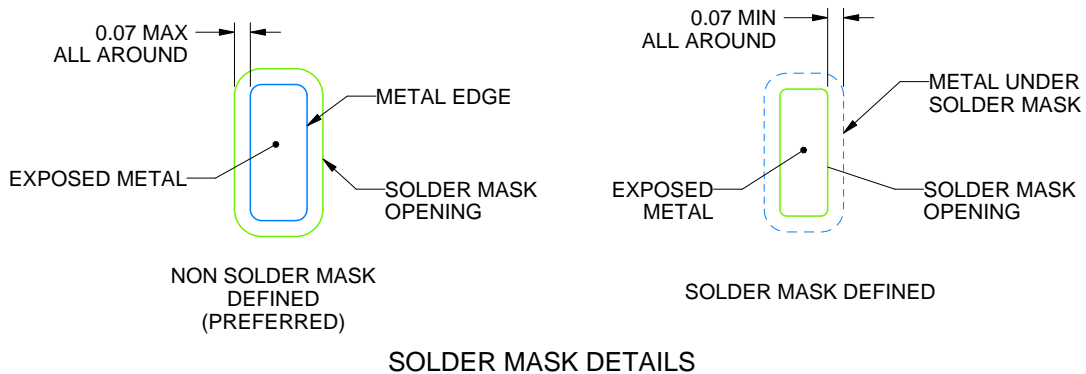

SOLDER MASK DETAILS

4226528/D 04/2024

NOTES: (continued)

4. This package is designed to be soldered to a thermal pad on the board. For more information, see Texas Instruments literature number SLUA271 (www.ti.com/lit/sluea271).
5. Vias are optional depending on application, refer to device data sheet. If any vias are implemented, refer to their locations shown on this view. It is recommended that vias under paste be filled, plugged or tented.

EXAMPLE STENCIL DESIGN

RYP0016A

VQFN-FCRLF - 1.05 mm max height

PLASTIC QUAD FLATPACK - NO LEAD

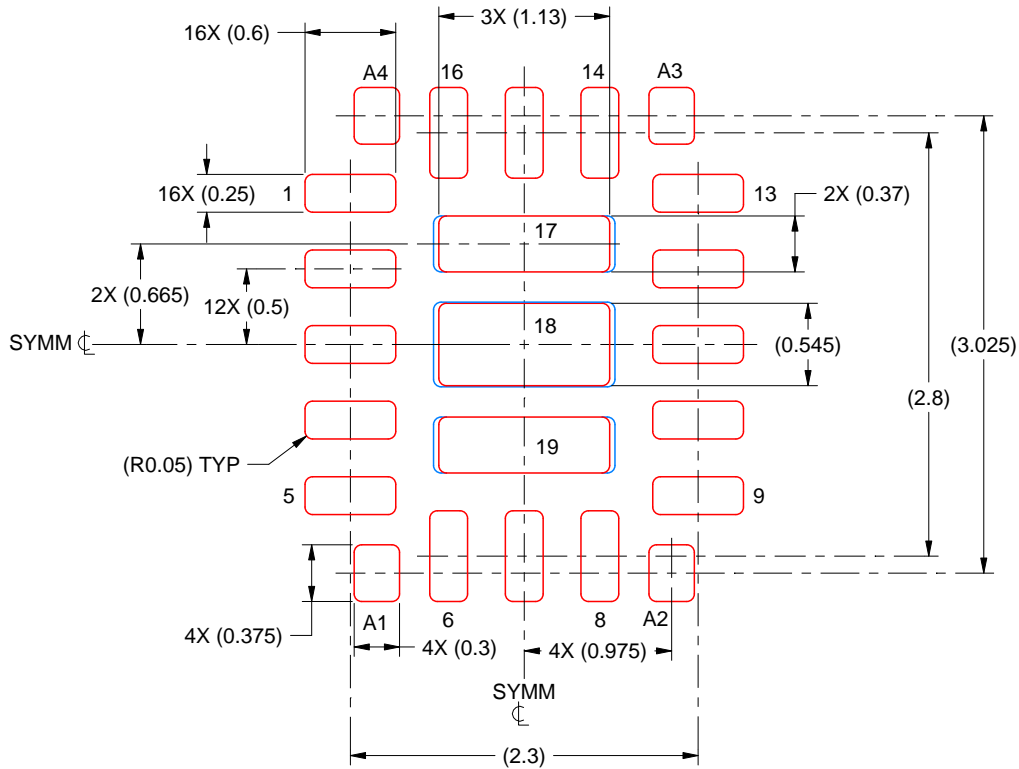

SOLDER PASTE EXAMPLE
 BASED ON 0.125 MM THICK STENCIL
 SCALE: 20X

PRINTED SOLDER COVERAGE BY AREA UNDER PACKAGE
 PADS 17 & 19: 94%
 PAD 18: 92%

4226528/D 04/2024

NOTES: (continued)

6. Laser cutting apertures with trapezoidal walls and rounded corners may offer better paste release. IPC-7525 may have alternate design recommendations.

IMPORTANT NOTICE AND DISCLAIMER

TI PROVIDES TECHNICAL AND RELIABILITY DATA (INCLUDING DATASHEETS), DESIGN RESOURCES (INCLUDING REFERENCE DESIGNS), APPLICATION OR OTHER DESIGN ADVICE, WEB TOOLS, SAFETY INFORMATION, AND OTHER RESOURCES "AS IS" AND WITH ALL FAULTS, AND DISCLAIMS ALL WARRANTIES, EXPRESS AND IMPLIED, INCLUDING WITHOUT LIMITATION ANY IMPLIED WARRANTIES OF MERCHANTABILITY, FITNESS FOR A PARTICULAR PURPOSE OR NON-INFRINGEMENT OF THIRD PARTY INTELLECTUAL PROPERTY RIGHTS.

These resources are intended for skilled developers designing with TI products. You are solely responsible for (1) selecting the appropriate TI products for your application, (2) designing, validating and testing your application, and (3) ensuring your application meets applicable standards, and any other safety, security, regulatory or other requirements.

These resources are subject to change without notice. TI grants you permission to use these resources only for development of an application that uses the TI products described in the resource. Other reproduction and display of these resources is prohibited. No license is granted to any other TI intellectual property right or to any third party intellectual property right. TI disclaims responsibility for, and you fully indemnify TI and its representatives against any claims, damages, costs, losses, and liabilities arising out of your use of these resources.

TI's products are provided subject to [TI's Terms of Sale](#), [TI's General Quality Guidelines](#), or other applicable terms available either on ti.com or provided in conjunction with such TI products. TI's provision of these resources does not expand or otherwise alter TI's applicable warranties or warranty disclaimers for TI products. Unless TI explicitly designates a product as custom or customer-specified, TI products are standard, catalog, general purpose devices.

TI objects to and rejects any additional or different terms you may propose.

Copyright © 2025, Texas Instruments Incorporated

Last updated 10/2025

Looking for pricing, stock, or lifecycle information?

Click below to explore more details on WIN SOURCE:

 [View TRF1305B2RYPR on WIN SOURCE](#)

 [Texas Instruments](#) Information

Optimize Your Supply Chain with WIN SOURCE Solutions

-  Global Sourcing Solution
-  Obsolete Management
-  Cost Control Management
-  Shortage Management
-  Alternative Solution
-  Excess Inventory Management