

# MR48V256C

32,768-Word × 8-Bit FeRAM (Ferroelectric Random Access Memory)

## GENERAL DESCRIPTION

The MR48V256C is a nonvolatile 32,768-word x 8-bit ferroelectric random access memory (FeRAM) developed in the ferroelectric process and silicon-gate CMOS technology. Unlike SRAMs, this device, whose cells are nonvolatile, eliminates battery backup required to hold data. This device has no mechanisms of erasing and programming memory cells and blocks, such as those used for various EEPROMs. Therefore, the write cycle time can be equal to the read cycle time and the power consumption during a write can be reduced significantly. The MR48V256C can be used in various applications, because the device is guaranteed for the write/read tolerance of  $10^{12}$  cycles per bit and the rewrite count can be extended significantly.

## FEATURES

- 32,768-word × 8-bit configuration
- A single 2.7 to 3.6V power supply
- Read access time: 70 ns (Max.)
- Write enable time: 70 ns (Min.)
- Random read/write cycle time 150 ns (Min.)
- Read/write tolerance  $10^{12}$  cycles/bit
- Data retention 10 years
- Guaranteed operating temperature range -40 to 85°C (Extended temperature version)
- Package options:  
28-pin plastic TSOPI (TSOP(1)28-08134-0.55-ZK6)

## PRODUCT FAMILY

Family	Access Time		Read/Write Cycle Time	Package
	Relative to CE	Relative to OE		
MR48V256C	70ns	40ns	150ns	28pin TSOPI

**PIN CONFIGURATION**

28-pin plastic TSOP1  
P-TSOP(1)28-08134-0.55-ZK6

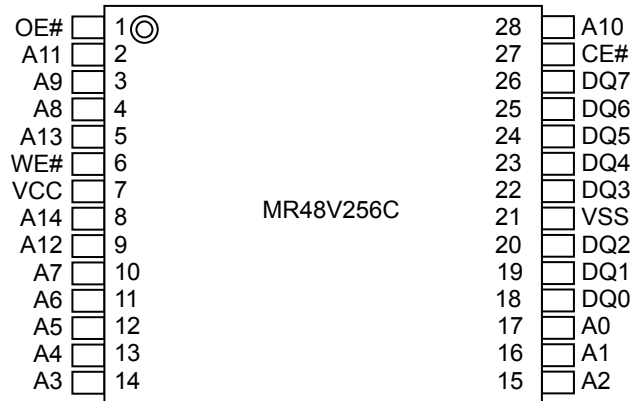

Note:

Signal names that end with # indicate that the pins are negative-true logic.

## PIN DESCRIPTIONS

Pin Name	Description
CE#	Chip enable (input, negative logic) Latches an address by low input, activates the FeRAM, and enables a read or write operation.
OE#	Output enable (input, negative logic) The FeRAM is in read mode when the FeRAM is active and this pin is low, and data is output after the specified time.
WE#	Write enable (input, negative logic) The FeRAM is in write mode when the FeRAM is active and this pin is low, and data is capture at the timing of WE#="H" or CE#="H", whichever is earlier.
A14 to A0	Address (input) The FeRAM captures an address at the timing when CE#="L" is established.
DQ7 to DQ0	3-state data bus (input/output) Outputs data in the read mode, and captures data in the write mode.
V <sub>CC</sub> , V <sub>SS</sub>	Power supply Apply the specified voltage to V <sub>CC</sub> . Connect V <sub>SS</sub> to ground.

## TRUTH TABLE

Operating Mode	CE#	WE#	OE#
Standby Mode	H	X	X
	X	H	H
Address Latched	↓	H	L
	↓	L	H
	L	↓	H
	L	H	↓
Read Mode	L	H	L
Write Mode	L	L	H

Note:

Having WE# and OE# "L" at the same time is forbidden.

## ELECTRICAL CHARACTERISTICS

### Absolute Maximum Ratings

Parameter	Symbol	Rating		Unit	Note
		Min.	Max.		
Pin Voltage (Input Signal)	$V_{IN}$	-0.5	$V_{CC} + 0.5$	V	
Pin Voltage (Input/Output Voltage)	$V_{INQ}, V_{OUTQ}$	-0.5	$V_{CC} + 0.5$	V	
Power Supply Voltage	$V_{CC}$	-0.5	4.6	V	
Storage Temperature (Extended Temperature Version)	$T_{stg}$	-55	125	°C	
Operating Temperature (Extended Temperature Version)	$T_{opr}$	-40	85	°C	
Power Dissipation	$P_D$	1,000		mW	
Allowable Input Current	$I_{IN}$	±20		mA	$T_a = 25^\circ\text{C}$
Allowable Output Current	$I_{OUT}$	±20		mA	$T_a = 25^\circ\text{C}$

Note:

The application of stress (voltage, current, or temperature) that exceeds the absolute maximum rating may damage the device. Therefore, do not allow actual characteristics to exceed any one parameter ratings

### Recommended Operating Conditions ( $V_{SS}=0\text{V}$ )

Parameter	Symbol	Min.	Max.	Unit	Note
Power Supply Voltage	$V_{CC}$	2.7	3.6	V	3.3V typ.
Input High Voltage	$V_{IH}$	$V_{CC} \times 0.8$	$V_{CC} + 0.3$	V	1
Input Low Voltage	$V_{IL}$	-0.3	$V_{CC} \times 0.15$	V	2
Operating Temperature (Extended Temperature Version)	$T_a$	-40	85	°C	

Notes:

1. Overshoots with the pulse width of 20 ns or less and the voltage of  $V_{CC} + 1.0\text{ V}$  or less are allowed.
2. Undershoots with the pulse width of 20 ns or less and the voltage of  $-1.0\text{ V}$  or more are allowed.
3. The voltages are referenced to VSS

### Capacitance

Parameter	Symbol	Min.	Max.	Unit	Note
Input Capacitance	$C_{IN}$	—	6	pF	1
Input/Output Capacitance	$C_{OUT}$	—	8	pF	1

Note:

Sampling value. Measurement conditions are  $V_{IN} = V_{OUT} = \text{GND}$ ,  $f = 1\text{MHz}$ , and  $T_a = 25^\circ\text{C}$

**DC Characteristics**

(Under recommended operating conditions)

Parameter	Symbol	Condition	Min.	Max.	Unit	Note
Output High Voltage	$V_{OH}$	$I_{OH} = -2 \text{ mA}$	$V_{CC} \times 0.85$	—	V	
Output Low Voltage	$V_{OL}$	$I_{OL} = 2 \text{ mA}$	—	$V_{CC} \times 0.15$	V	
Input Leakage Current	$I_{LI}$	—	-10	10	$\mu\text{A}$	
Output Leakage Current	$I_{LO}$	—	-10	10	$\mu\text{A}$	
Power Supply Current (Standby)	$I_{CCS}$	$V_{IN} = 0.2\text{V}$ or $V_{CC}-0.2\text{V}$ , $CE\# = V_{CC}-0.2\text{V}$ $I_{OUT} = 0 \text{ mA}$	—	400	$\mu\text{A}$	
Power Supply Current (Operating)	$I_{CCA}$	Read Cycle, $t_{RC} = \text{Min.}$ $V_{IN} = 0.2\text{V}$ or $V_{CC}-0.2\text{V}$ , $CE\# = 0.2\text{V}$ , $I_{OUT} = 0 \text{ mA}$	—	10	$\text{mA}$	1

Note:

1. Average current. Address change must be one time or less during time  $t_{RC}$ .

**Read/Write Cycles and Data Retention**

(Under recommended operating conditions)

Parameter	Min.	Max.	Unit	Note
Read/Write Cycle	$10^{12}$	—	Cycle	1
Data Retention	10	—	Year	

Notes:

1. This is applicable to the read cycle, write cycle, and CE-only cycle counts.  
This is the cycle count per bit (for one address).

**AC Characteristics (Read Cycle)**

(Under recommended operating conditions)

Parameter	Symbol	-70		Unit	Note
		Min.	Max.		
Address Set-up Time	$t_{AVEL}$	0	—	ns	
Address Hold Time (CE#)	$t_{ELAX}$	10	—	ns	
CE# High Pulse Width	$t_{EHEL}$	80	—	ns	
Output Hold Time (CE#)	$t_{EHQX}$	5	—	ns	
Output High Impedance Time (CE#)	$t_{EHQZ}$	—	25	ns	
CE# Active Time	$t_{ELEH}$	70	2000	ns	
Read Cycle Time (CE# cycle Time)	$t_{ELEL}$	150	—	ns	
CE# Access Time	$t_{ELQV}$	—	70	ns	1
Output Low Impedance Time (CE#)	$t_{EHQX}$	5	—	ns	
Output Hold Time (OE#)	$t_{GHQX}$	5	—	ns	
Output High Impedance Time (OE#)	$t_{GHQZ}$	—	25	ns	
OE# Access Time	$t_{GLQV}$	—	70	ns	1
Output Low Impedance Time (OE#)	$t_{GLQX}$	5	—	ns	

Notes:

1. The read data is output at the point where all of the maximum values of  $t_{ELQV}$  and  $t_{GLQV}$  are satisfied.

**AC Characteristics (Write Cycle)**

(Under recommended operating conditions) Note 1

Parameter	Symbol	-70		Unit	Note
		Min.	Max.		
Address Set-up Time	$t_{AVEL}$	0	—	ns	
Data Set-up Time (WE#)	$t_{DVWH}$	40	—	ns	
Data Set-up Time (CE#)	$t_{DVEH}$	40	—	ns	
Address Hold Time (CE#)	$t_{ELAX}$	10	—	ns	
Data Hold Time (CE#)	$t_{EHDX}$	0	—	ns	
CE# High Pulse Width	$t_{EHEL}$	80	—	ns	
CE# Active Time	$t_{ELEH}$	70	2000	ns	
Write Cycle Time (CE# Cycle Time)	$t_{ELEL}$	150	—	ns	
Data Hold Time (WE#)	$t_{WHDX}$	0	—	ns	

**Timing Diagrams**

•Read cycle, CE# Control Read

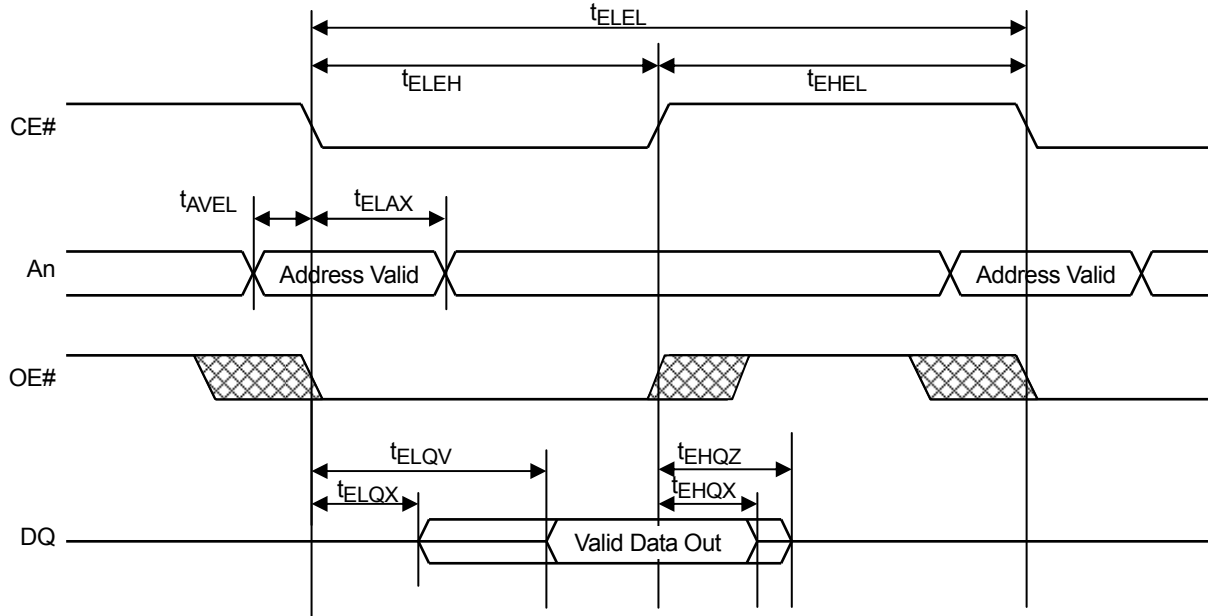

Note: WE# = "H"

•Read cycle, OE# Control Read

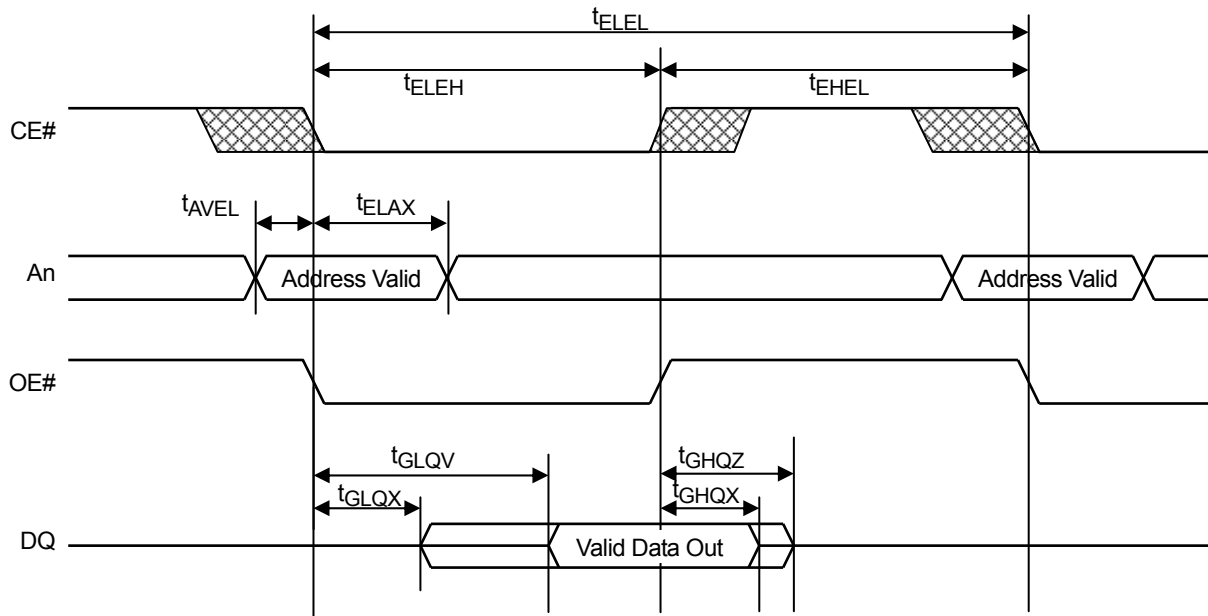

Note: WE# = "H"

•Write cycle, CE# Control Write

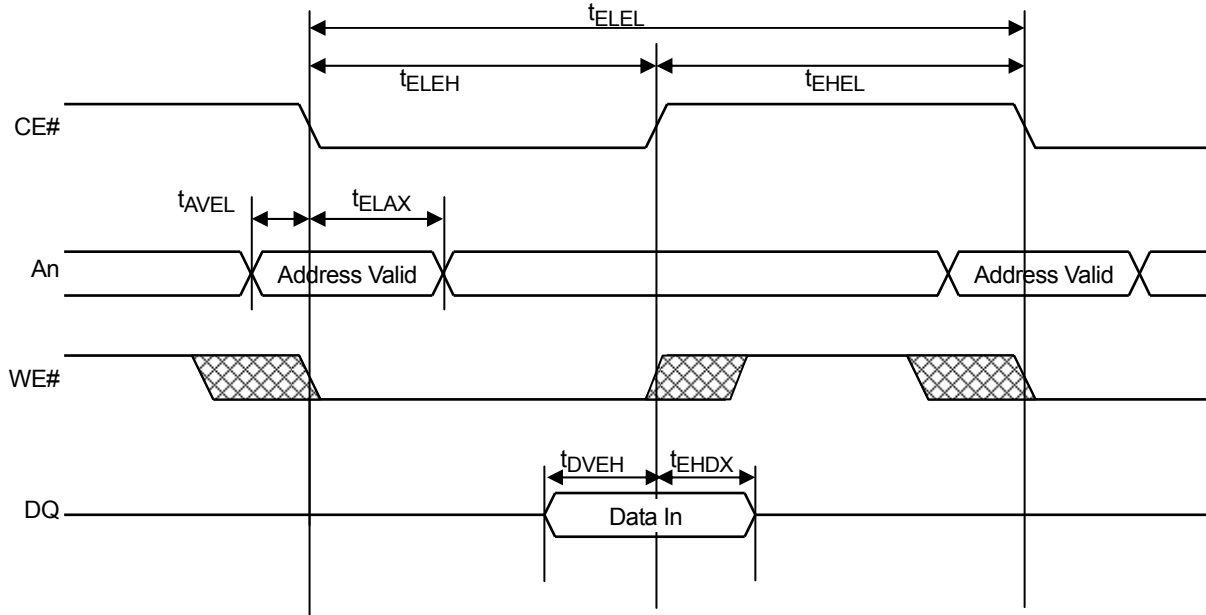

Note: OE# = "H"

•Write cycle, WE# Control Write

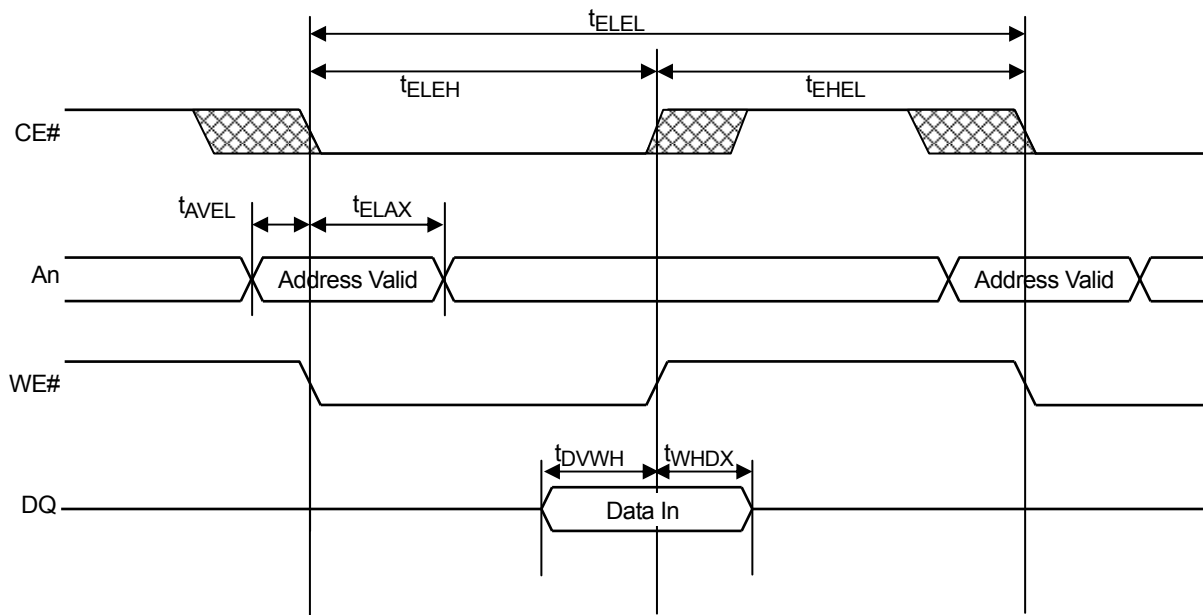

注記: OE#="H"

•Power-On and Power-Off Characteristics

(Under recommended operating conditions)

Parameter	Symbol	Min.	Max.	Unit	Note
Power-On CE# High Hold Time	$t_{VHEL}$	50	—	$\mu\text{s}$	1, 2
Power-Off CE# High Hold Time	$t_{EHVL}$	100	—	ns	1
Power-On Interval Time	$t_{VLVH}$	1	—	$\mu\text{s}$	2

Notes:

1. To prevent an erroneous operation, be sure to maintain CE#="H", and set the FeRAM in an inactive state (standby mode) before and after power-on and power-off.
2. Powering on at the intermediate voltage level will cause an erroneous operation; thus, be sure to power up from 0 V.
3. Enter all signals at the same time as power-on or enter all signals after power-on.

•Power-On and Power-Off Sequences

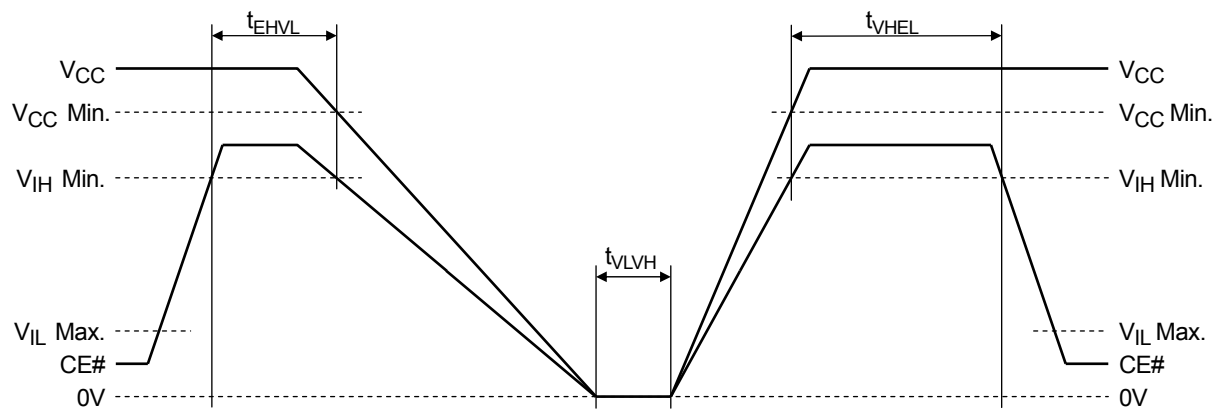

**PACKAGE DIMENSIONS**

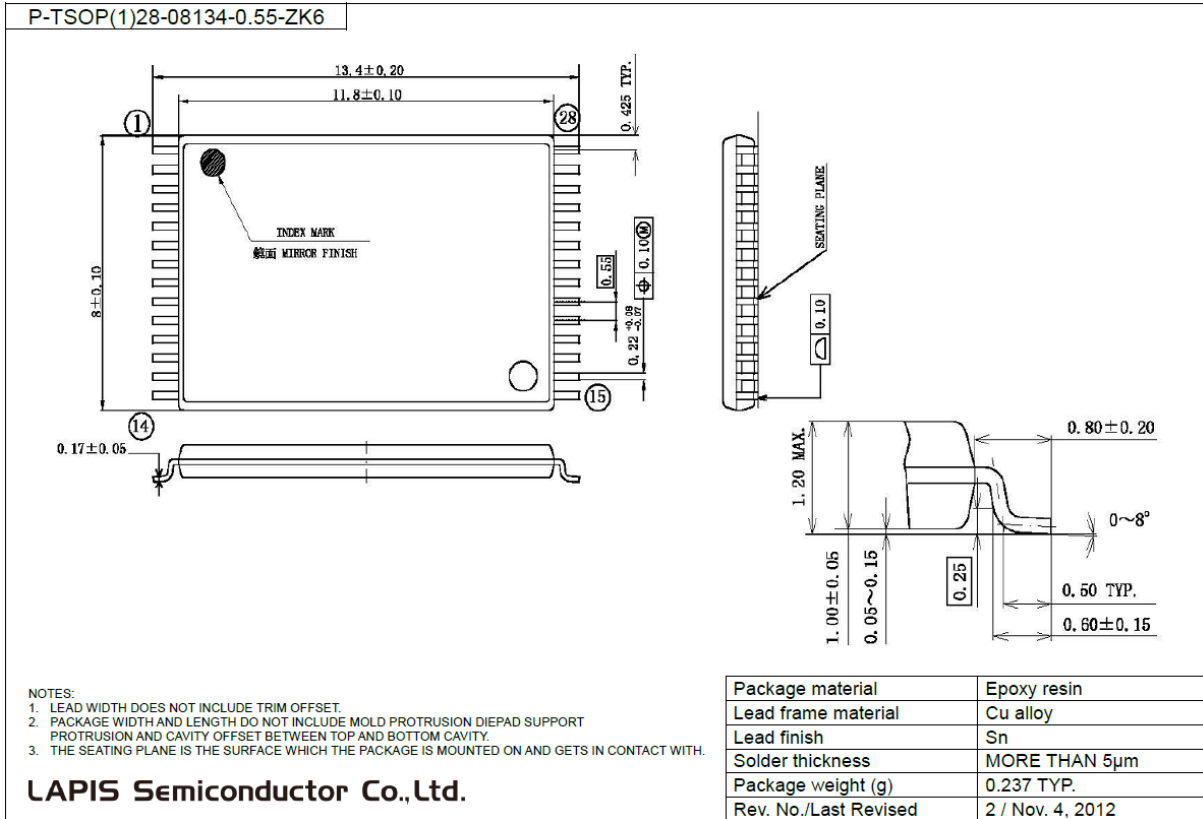

Notes for Mounting the Surface Mount Type Package

The surface mount type packages are very susceptible to heat in reflow mounting and humidity absorbed in storage. Therefore, before you perform reflow mounting, contact ROHM's responsible sales person for the product name, package name, pin number, package code and desired mounting conditions (reflow method, temperature and times).

**REVISION HISTORY**

Document No.	Date	Page		Description
		Previous Edition	Current Edition	
FEDR48V256C-01	Nov. 13, 2013	-	-	Final Edition 1

NOTES

No copying or reproduction of this document, in part or in whole, is permitted without the consent of LAPIS Semiconductor Co., Ltd.

The content specified herein is subject to change for improvement without notice.

The content specified herein is for the purpose of introducing LAPIS Semiconductor's products (hereinafter "Products"). If you wish to use any such Product, please be sure to refer to the specifications, which can be obtained from LAPIS Semiconductor upon request.

Examples of application circuits, circuit constants and any other information contained herein illustrate the standard usage and operations of the Products. The peripheral conditions must be taken into account when designing circuits for mass production.

Great care was taken in ensuring the accuracy of the information specified in this document. However, should you incur any damage arising from any inaccuracy or misprint of such information, LAPIS Semiconductor shall bear no responsibility for such damage.

The technical information specified herein is intended only to show the typical functions of and examples of application circuits for the Products. LAPIS Semiconductor does not grant you, explicitly or implicitly, any license to use or exercise intellectual property or other rights held by LAPIS Semiconductor and other parties. LAPIS Semiconductor shall bear no responsibility whatsoever for any dispute arising from the use of such technical information.

The Products specified in this document are intended to be used with general-use electronic equipment or devices (such as audio visual equipment, office-automation equipment, communication devices, electronic appliances and amusement devices).

The Products specified in this document are not designed to be radiation tolerant.

While LAPIS Semiconductor always makes efforts to enhance the quality and reliability of its Products, a Product may fail or malfunction for a variety of reasons.



Please be sure to implement in your equipment using the Products safety measures to guard against the possibility of physical injury, fire or any other damage caused in the event of the failure of any Product, such as derating, redundancy, fire control and fail-safe designs. LAPIS Semiconductor shall bear no responsibility whatsoever for your use of any Product outside of the prescribed scope or not in accordance with the instruction manual.

The Products are not designed or manufactured to be used with any equipment, device or system which requires an extremely high level of reliability the failure or malfunction of which may result in a direct threat to human life or create a risk of human injury (such as a medical instrument, transportation equipment, aerospace machinery, nuclear-reactor controller, fuel-controller or other safety device). LAPIS Semiconductor shall bear no responsibility in any way for use of any of the Products for the above special purposes. If a Product is intended to be used for any such special purpose, please contact a ROHM sales representative before purchasing. If you intend to export or ship overseas any Product or technology specified herein that may be controlled under the Foreign Exchange and the Foreign Trade Law, you will be required to obtain a license or permit under the Law.

Copyright 2013 LAPIS Semiconductor Co., Ltd.

## Looking for pricing, stock, or lifecycle information?

Click below to explore more details on WIN SOURCE:

-  [View MR48V256CTAZAARL on WIN SOURCE](#)
-  [Rohm Semiconductor](#) Information

## Optimize Your Supply Chain with WIN SOURCE Solutions

-  Global Sourcing Solution
-  Obsolete Management
-  Cost Control Management
-  Shortage Management
-  Alternative Solution
-  Excess Inventory Management