

Installation Instructions for the SMART Position Sensor, Rotary Configuration

ISSUE 2
50069156

The SMART Position Sensor, rotary configuration, is a non-contacting sensing solution for absolute position sensing with enhanced accuracy. It senses the position of a magnet relative to the sensor in a range of 0° to 360°.

The SMART Position Sensor, rotary configuration, fits on a 25,4 mm [1 in] shaft. A mounting tool fixture (one piece or two piece, purchased separately) provides repeatable installation.

MOUNTING AND WIRING INFORMATION (See Figures 1, 2, 3, 4.)

1. Locate sensor and magnet collar in the desired position. Ensure that the air gap between sensor and magnet does not exceed that noted in Table 1.
2. Mount sensor on shaft using an assembly tool.
3. Mount magnet collar.
4. Wire sensor according to pinout.

Table 1. Specifications¹

Characteristic	Component	Parameter	Note
Sensing range	sensor only	360°	–
Resolution		0.01°	–
Supply voltage		12 Vdc to 30 Vdc	–
Output		4 mA to 20 mA	–
Supply current		90 mA max.	–
Linearity: 25 °C [77 °F] TC: ≥85 °C [158 °F]		-0.03 %FS min., 0.030 %FS max. 0.0011 %FS/°C	2, 4, 7
Offset: 25 °C [77 °F] TC: ≥85 °C [158 °F]		-0.044 %FS min., -0.011 %FS typ., 0.022 %FS max. 0.0033 %FS/°C	3, 4, 5, 7
Accuracy		-0.069 %FS min., 0.069 %FS max.	4
Sensitivity: 25 °C [77 °F] TC: ≥85 °C [158 °F]		44.43 µA/° min., 44.43 µA/° typ., 44.48 µA/° max. 80 ppm/°C	6, 7
Reverse polarity		-12 Vdc to -30 Vdc	–
Initial startup time		130 ms typ.	–
Termination		M12 connector, male 5 pin	–
Operating temperature		sensor and magnet collar	-40 °C to 85 °C [-40 °F to 185 °F]
Storage temperature	-40 °C to 150 °C [-40 °F to 302 °F]		–
Air gap	3,0 mm ±2,0 mm [0.118 in ±0.079 in] typ.		–
Sealing	IP67, IP69K		–
Shock	50 G half sine wave with 11 ms duration		–
Vibration	20 G from 10 Hz to 2000 Hz		–
Housing material	aluminum with powder coating		–
Approvals	CE		–
Mounting: screws recommended torque	M5 or UNC 10-24 5 N m to 7 N m [44.25 in lb to 61.95 in lb]		–
Material	magnet only		neodymium (sintered NdFeB)
Strength		3700 Gauss	–

Notes:

1. Specifications are based on a non-ferrous shaft.
2. Linearity: Deviations from a best fit straight line through the output, expressed as a percentage of the full scale signal range (% of 16 mA).
3. Accuracy: Deviations from the ideal output line expressed as a percentage of the full scale signal range (% of 16 mA).
4. %FS: Error expressed as a percentage of the output span of the sensor (% of 16 mA).
5. Offset: Deviation from the ideal output at the minimum input condition, expressed as a percentage of the full scale signal range (% of 16 mA).
6. Sensitivity: The slope of the output signal vs magnet travel, expressed as µA of output per degree of travel.
7. TC: Temperature coefficient of a given parameter, as a percentage of the full scale signal range (% of 16 mA) per degree of temperature rise from 25 °C [77 °F].

NOTICE

CONTROLLABLE FACTORS THAT AFFECT ACCURACY: TOLERANCE STACK-UP IN THE APPLICATION

Customers can achieve even better accuracy with Honeywell's SMART Position Sensor, Rotary Configuration, if they control tolerance stack-up in their application's assembled system. This is the accumulation of errors (slightly out-of-round shafts, minor eccentric component rotations, loose linkages and other variations) that, in and of themselves, may be extremely small on their own; however, when added up, can greatly reduce sensor accuracy, causing unsatisfactory sensor performance.

Table 2. % Linearity

		Radial Error (mm)									
		0	0.05	0.1	0.25	0.5	0.75	1	1.5	2	2.5
Air Gap Error (mm)	-2	-0.005	0.001	0.007	0.027	0.066	0.113	0.166	0.294	0.450	0.635
	-1	-0.002	0.003	0.008	0.025	0.060	0.101	0.150	0.269	0.417	0.593
	0	0.000	0.004	0.008	0.023	0.053	0.090	0.135	0.245	0.383	0.550
	1	0.002	0.005	0.009	0.021	0.047	0.079	0.119	0.220	0.350	0.508
	2	0.005	0.007	0.009	0.019	0.040	0.068	0.104	0.196	0.317	0.466
	3	0.007	0.008	0.010	0.017	0.033	0.057	0.088	0.172	0.284	0.424

Table 3. % Accuracy

		Radial Error (mm)									
		0	0.05	0.1	0.25	0.5	0.75	1	1.5	2	2.5
Air Gap Error (mm)	-2	0	0.006	0.012	0.033	0.076	0.129	0.191	0.263	0.538	0.770
	-1	0	0.005	0.011	0.029	0.069	0.118	0.176	0.245	0.509	0.733
	0	0	0.004	0.009	0.026	0.061	0.106	0.162	0.226	0.479	0.697
	1	0	0.004	0.008	0.022	0.054	0.095	0.147	0.208	0.450	0.660
	2	0	0.003	0.006	0.018	0.047	0.084	0.132	0.190	0.420	0.623
	3	0	0.002	0.005	0.015	0.039	0.073	0.117	0.171	0.391	0.586

Figure 1. Sensor

Dimensional Drawings (For reference only: mm)

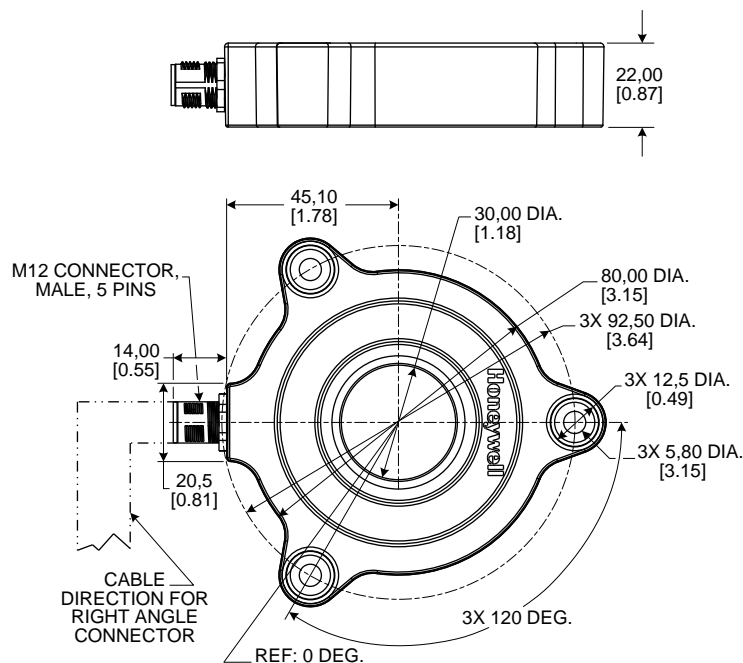

Figure 1. Sensor (continued)

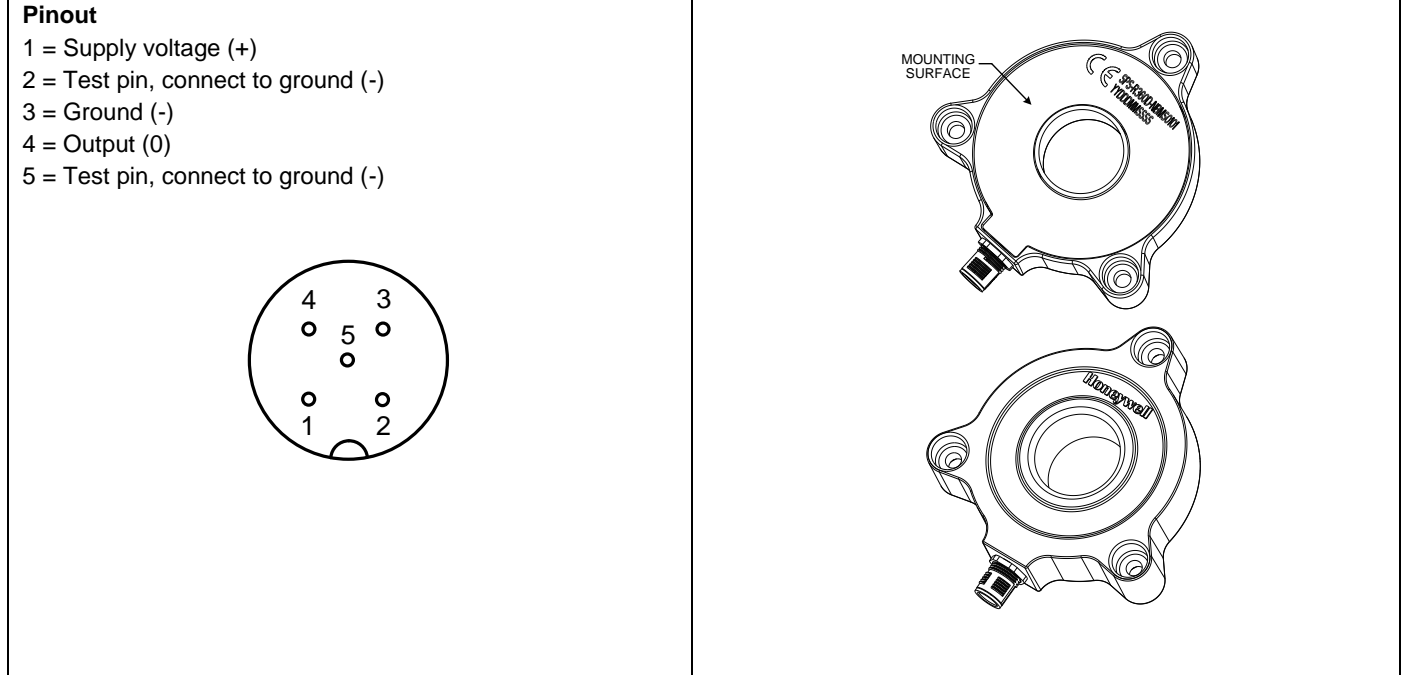
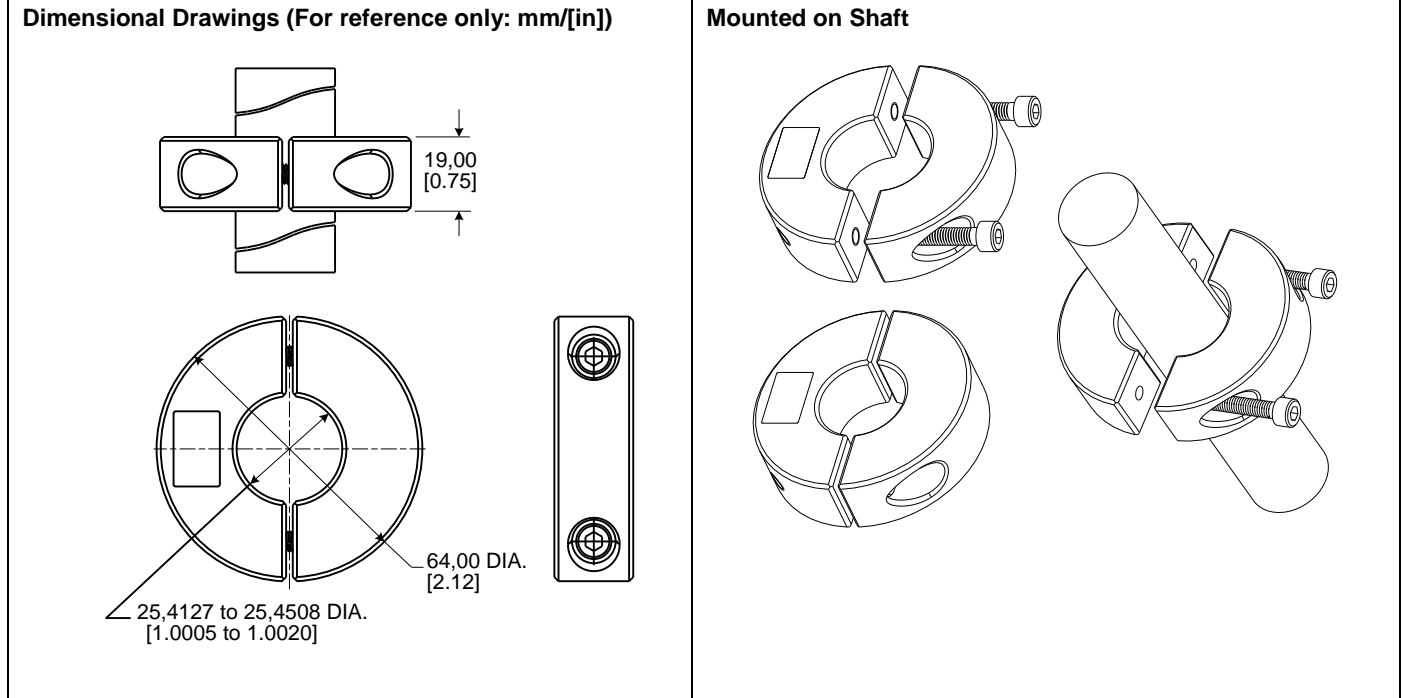

Figure 2. Magnet Collar



NOTICE

Stationary ferrous material often creates an initial offset upon installation. If the stationary ferrous material never moves in relation to the sensor after the installation, and the environment remains ferrous-free, performance should be repeatable. Ensure the sensor is tested in the application.

Figure 3. Assembly Tools

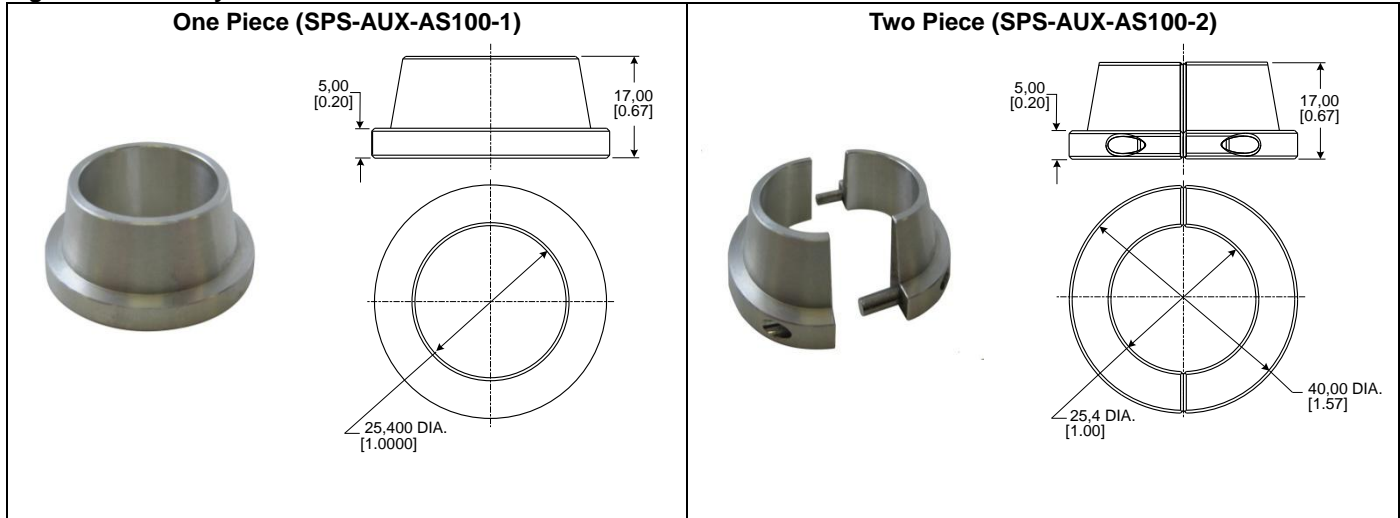

NOTICE

ASSEMBLY TOOL USE

Honeywell recommends using an assembly tool to help align the magnetic axis of rotation to the inside diameter of the Sensor.

Assembly Tool Use

1. Place the sensor over the shaft with its epoxy side facing the mating surface of the mounting plate.
2. Loosely assemble the mounting screws in the sensor.
3. Install the assembly tool on the shaft.
4. Push the assembly tool into the sensor to center on the shaft.
5. Tighten the sensor mounting screws while maintaining pressure on the assembly tool.
6. Remove the assembly tool.

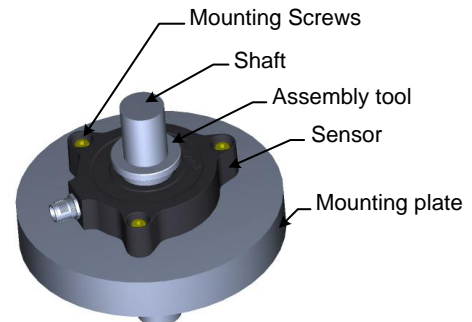
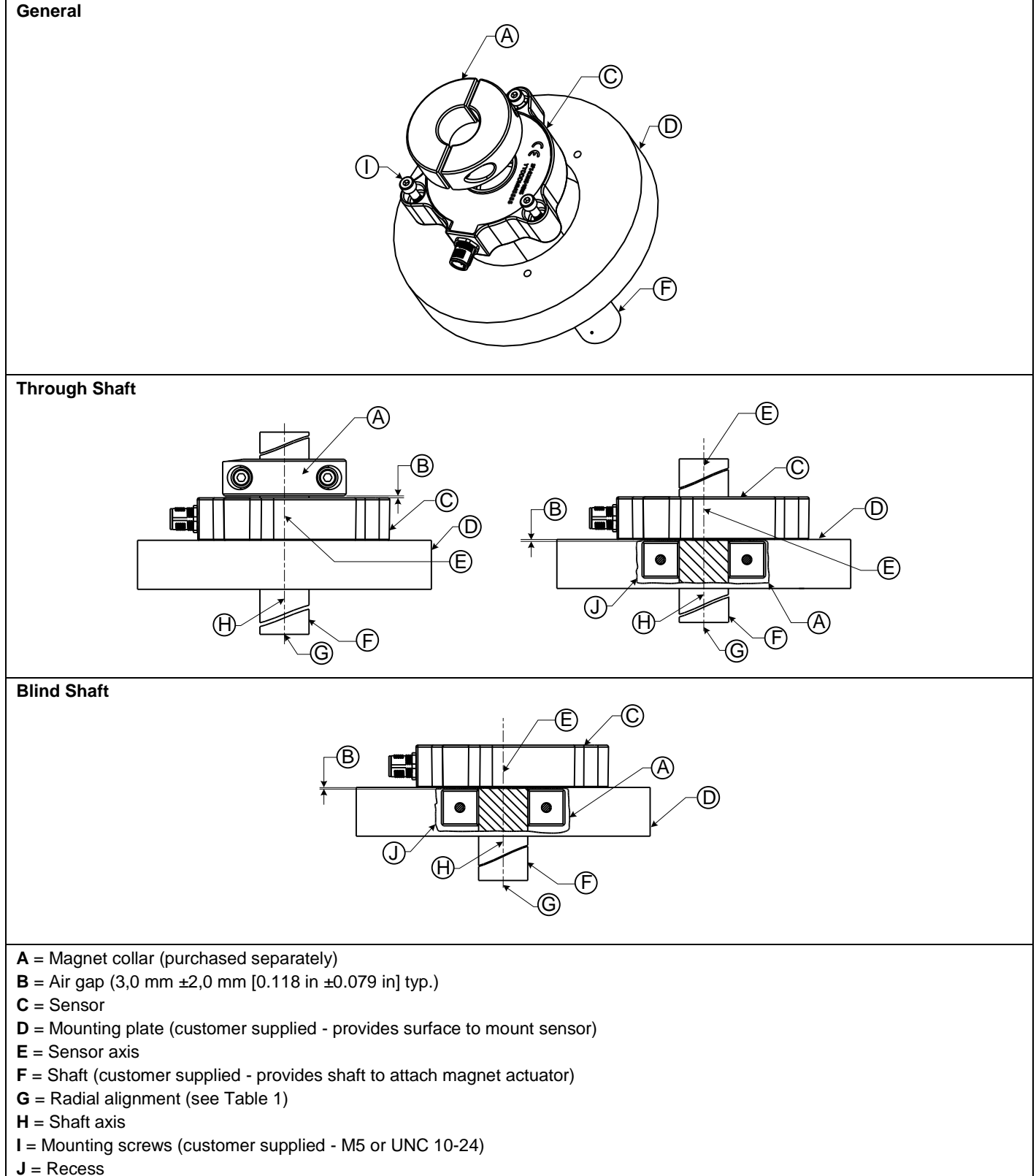

Figure 4. Sensor Mounting Examples



WARNING

PERSONAL INJURY

DO NOT USE these products as safety or emergency stop devices or in any other application where failure of the product could result in personal injury.

Failure to comply with these instructions could result in death or serious injury.

WARRANTY/REMEDY

Honeywell warrants goods of its manufacture as being free of defective materials and faulty workmanship. Honeywell's standard product warranty applies unless agreed to otherwise by Honeywell in writing; please refer to your order acknowledgement or consult your local sales office for specific warranty details. If warranted goods are returned to Honeywell during the period of coverage, Honeywell will repair or replace, at its option, without charge those items it finds defective. **The foregoing is buyer's sole remedy and is in lieu of all other warranties, expressed or implied, including those of merchantability and fitness for a particular purpose. In no event shall Honeywell be liable for consequential, special, or indirect damages.**

While we provide application assistance personally, through our literature and the Honeywell web site, it is up to the customer to determine the suitability of the product in the application.

Specifications may change without notice. The information we supply is believed to be accurate and reliable as of this printing. However, we assume no responsibility for its use.

SALES AND SERVICE

Honeywell serves its customers through a worldwide network of sales offices, representatives and distributors. For application assistance, current specifications, pricing or name of the nearest Authorized Distributor, contact your local sales office or:

E-mail: info.sc@honeywell.com

Internet: www.honeywell.com/sensing

Phone and Fax:

Asia Pacific	+65 6355-2828 +65 6445-3033 Fax
Europe	+44 (0) 1698 481481 +44 (0) 1698 481676 Fax
Latin America	+1-305-805-8188 +1-305-883-8257 Fax
USA/Canada	+1-800-537-6945 +1-815-235-6847 +1-815-235-6545 Fax

Looking for pricing, stock, or lifecycle information?

Click below to explore more details on WIN SOURCE:

 [View SPS-R360D-NBMS0101 on WIN SOURCE](#)

 [Honeywell Information](#)

Optimize Your Supply Chain with WIN SOURCE Solutions

-  Global Sourcing Solution
-  Obsolete Management
-  Cost Control Management
-  Shortage Management
-  Alternative Solution
-  Excess Inventory Management