

IST8210

Magnetic Angle

Sensor

Datasheet

Table of Contents

- 1 GENERAL DESCRIPTION3**

- 2 CIRCUIT DIAGRAM, OUTPUT SIGNAL, PACKAGE DIMENSION AND PIN DESCRIPTIONS. 4**
 - 2.1 Circuit Diagram4
 - 2.2 Output Signal.....4
 - 2.3 Package Dimensions.....5
 - 2.4 Pin Descriptions.....6
 - 2.5 Marking Information.....7

- 3 ELECTRICAL AND MAGNETIC SPECIFICATIONS7**
 - 3.1 Absolute Maximum Ratings.....7
 - 3.2 Recommended Operating Conditions8
 - 3.3 Detailed Specifications8

- 4 TECHNOLOGY OVERVIEW 9**
 - 4.1 AMR Technology9
 - 4.2 Advantages of AMR Technology9
 - 4.3 Features of IST8210 10
 - 4.4 Advantages of IST8210..... 10

1. General Description

iSentek IST8210 is a magnetic angle sensor with dimensions of $3.8 \times 4.9 \times 1.75 \text{ mm}^3$ in 8-pin SO8-packaging and $2.0 \times 2.0 \times 0.75 \text{ mm}^3$ in DFN-packaging. The sensor comprises two independent full Wheatstone bridges based on anisotropic magnetoresistance (AMR) effect. The sensor detects the direction of rotating magnetic field in the sensor plane, generating two sinusoidal output signals reflecting the angle θ between the sensor and direction of magnetic field. The function of the two outputs corresponding to the rotating field is $\text{Sin}(2\theta)$ and $\text{Cos}(2\theta)$.

Features

- Based on anisotropic magneto-resistance (AMR) technology
- Built by a pair of independent full Wheatstone Bridges generating output in sine and cosine wave form simultaneously
- Wide range of working temperature from -40°C to $+150^\circ\text{C}$
- RoHS, HF and TSCA compliant

Advantages

- Non-contact and wear-free angle measurement
- Insensitive to dust, water, oil, or other contaminations
- Excellent robustness against shocks and vibrations
- Constant sensitivity at very high operation field
- Allowing large working spacing
- High sensitivity
- Excellent precision even with weak operation magnetic field
- Negligible hysteresis effect
- Minimal output offset level

Applications

- Incremental or absolute position detection for linear or rotational motion
- Travel measurement
- Incremental or absolute angular gauges
- Motor communication
- Rotational speed measurement
- Angle measurement (180° absolute)
- Industrial robotics
- Valve control
- Power tools
- Automatic applications

2. Circuit Diagram, Output Signal, Package Dimension and Pin

Descriptions

2.1. Circuit Diagram

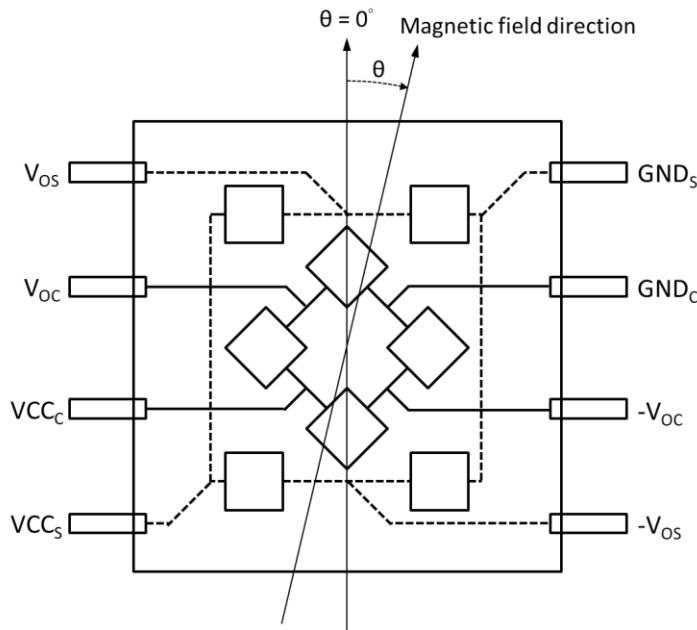

Figure 1. Circuit diagram and definition of magnetic field direction

2.2. Output Signal

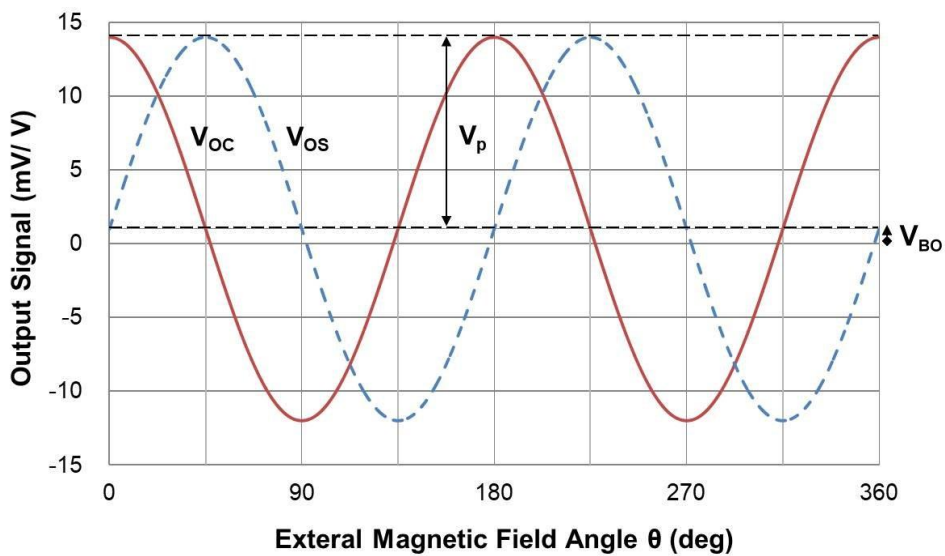
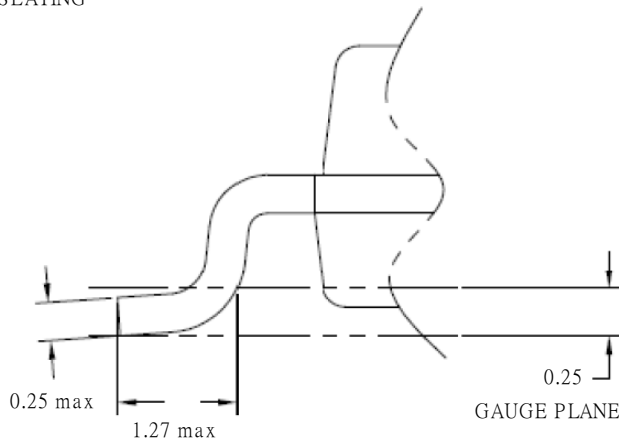
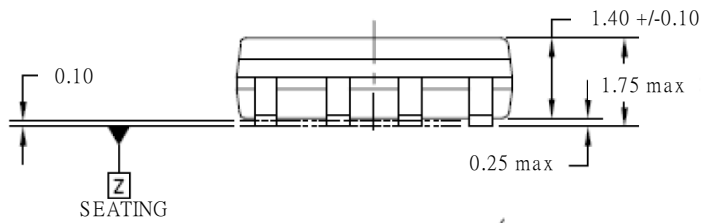
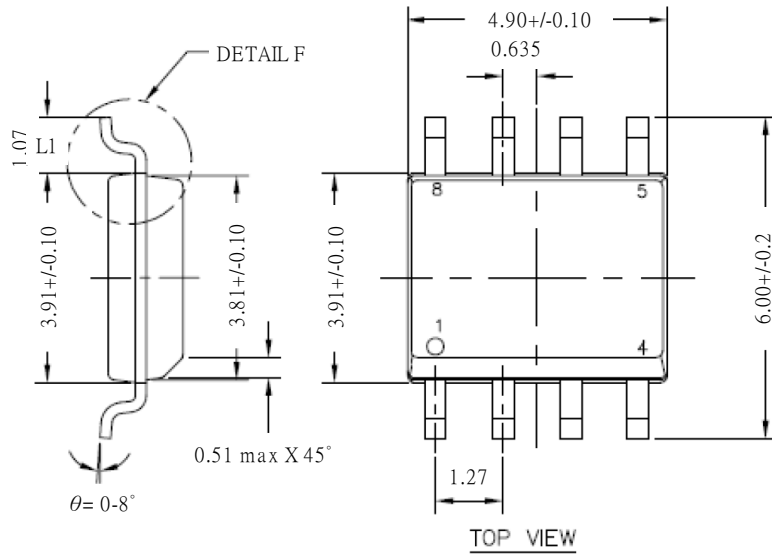

Figure 2. Sensor output as a function of the angle θ

2.3. Package Dimensions

8-pin S08-packaging



ROTATED 90° CCW
SCALE: 30/1

Unit: mm

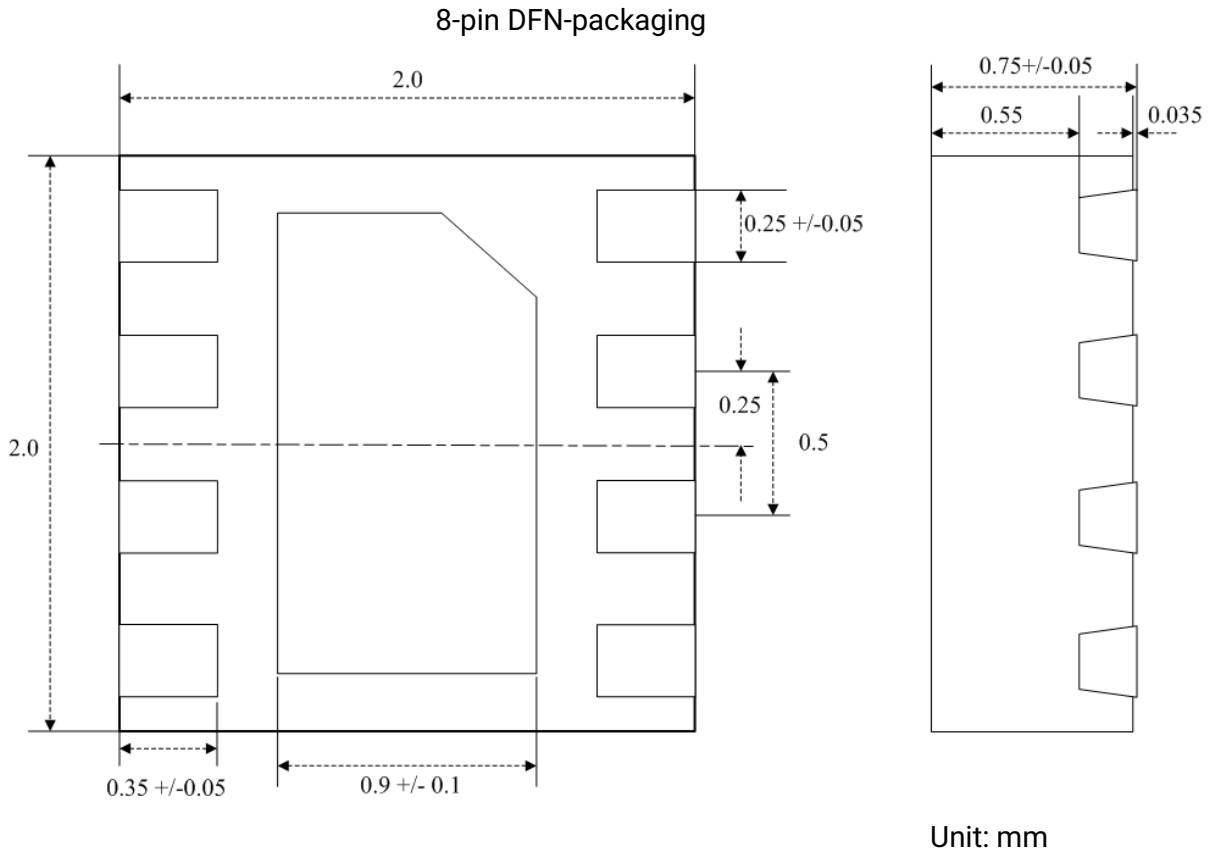

Figure 3. Package dimensions

2.4. Pin Descriptions

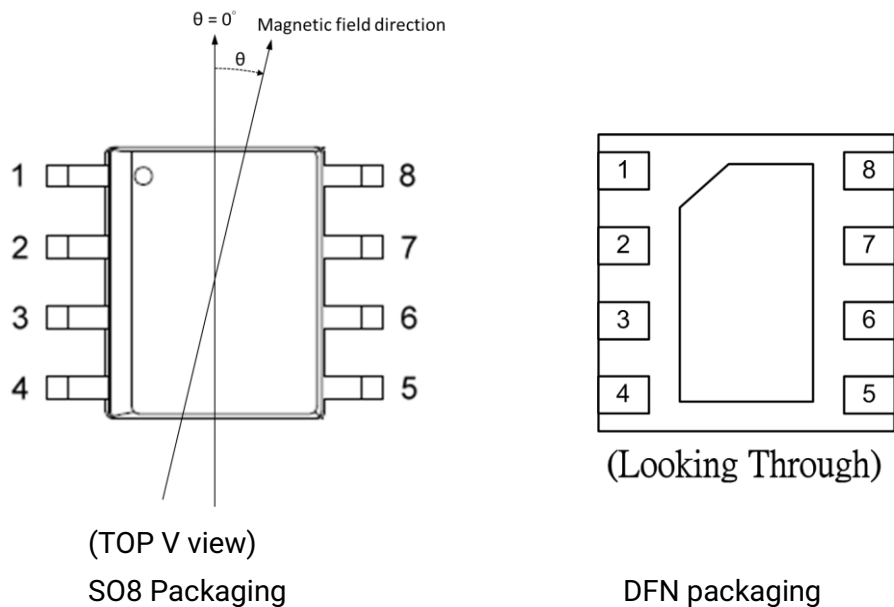

Figure 3. Pin Assignments

Pin ^{*1}	Name	Function
1	V _{OS}	Differential output voltage of sensing element S (Plus)
2	V _{OC}	Differential output voltage of sensing element C (Plus)
3	VCC _C	Supply voltage of sensing element C
4	VCC _S	Supply voltage of sensing element S
5	-V _{OS}	Differential output voltage of sensing element S (Minus)
6	-V _{OC}	Differential output voltage of sensing element C (Minus)
7	GND _C	Ground of sensing element C
8	GND _S	Ground of sensing element S

*1 Please refer to Figure 4 on page 6.

2.5. Marking Information

Product code 8210
Date code X₁X₂X₃●

X₁: Year
X₂: Week
X₃: Week

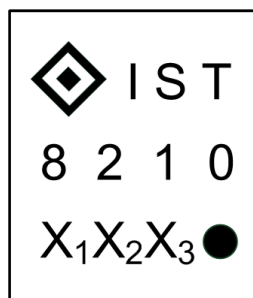

IST8210 TOP View
(SO8 Packaging)

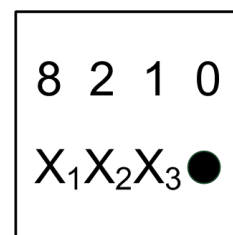

IST8210 TOP View
(DFN Packaging)

3. Electrical and Magnetic Specifications

3.1. Absolute Maximum Ratings

Parameter	Symbol	Limits	Unit
Storage temperature	TSTG	-40 and 150	°C
Supply voltage of sensing element S	VCC _S	±9	V
Supply voltage of sensing element C	VCC _C	±9	V
Floor life (≤ 30°C/60% RH)	t _{FL}	1	Year
Moisture sensitivity level	MSL	2	

3.2. Recommended Operating Conditions

Parameter	Symbol	Min.	Typ.	Max.	Unit
Operating temperature	T _O	-40		150	°C
Operation magnetic field strength	H _{OP}		320*1		Gauss
Supply voltage of element S	VCC _S		5		V
Supply voltage of element C	VCC _C		5		V

*1 Should be higher than 320 Gauss.

3.3. Detailed Specifications

(Operating conditions: T_O = +25 °C; H_{op} = 320 G; VCC_S = 5 V; VCC_C = 5 V; unless otherwise specified)

Parameter	Symbol	Condition	Min.	Typ.	Max	Unit
Supply voltage of element S	VCC _S	T _O = -40 to 150 °C		5	9	V
Supply voltage of element C	VCC _C	T _O = -40 to 150 °C		5	9	V
Bridge resistance*1	R _B		2.7	3.2	3.7	kΩ
Temperature coefficient of R _B *2	C _{TR}	T _O = -40 to 150 °C	0.38	0.42	0.46	%/K
Bridge offset per VCC	V _{BO}	Refer to Fig. 2	-2		+2	mV/V
Temperature coefficient of V _{BO} *3	C _{TO}	T _O = -40 to 150 °C	-2		+2	μV/V/ K
Sensitivity*4	S	θ _S = 0°; θ _C = 135°	2.1	2.35	2.6	mV/de g
Temperature coefficient of S*5	C _{TS}	T _O = -40 to 150 °C	-0.31	-0.35	-0.39	%/K
Signal amplitude per VCC*6	V _P	Refer to Fig. 2	12	13	14	mV/V
Temperature coefficient of V _P *7	C _{TP}	T _O = -40 to 150 °C	-0.31	-0.35	-0.39	%/K
Operation magnetic field strength*8	H _{OP}			320		Gauss
Angular error*9	Δθ		0	0.05	0.1	deg
Output amplitude synchronism*10	a _{sy}		-0.5	0	+0.5	% of V _P
Angular velocity of operation field	ω		0		1	MHz

*1 The resistance between pins 1 and 5, 2 and 6, 3 and 7, and 4 and 8.

$$*2 C_{TR} = 100 \times \frac{R_{B@T_{O2}} - R_{B@T_{O1}}}{R_{B@T_{O1}} (T_{O2} - T_{O1})}, \text{ where } T_{O1} = -40^{\circ}\text{C, and } T_{O2} = +150^{\circ}\text{C.}$$

$$*3 C_{TO} = \frac{V_{BO@T_{O2}} - V_{BO@T_{O1}}}{T_{O2} - T_{O1}}, \text{ where } T_{O1} = -40^{\circ}\text{C, and } T_{O2} = +150^{\circ}\text{C.}$$

*4 Sensitivity of the elements alters with angle θ due to sinusoidal output.

*5 $C_{TS} = 100 \times \frac{S_{@T_{02}} - S_{@T_{01}}}{S_{@T_{01}}(T_{02} - T_{01})}$, where $T_{01} = -40^{\circ}\text{C}$, and $T_{02} = 150^{\circ}\text{C}$.

*6 Maximal signal output voltage after zeroing bridge offset.

*7 $C_{TP} = 100 \times \frac{V_{P@T_{02}} - V_{P@T_{01}}}{V_{P@T_{01}}(T_{02} - T_{01})}$, where $T_{01} = -40^{\circ}\text{C}$, and $T_{02} = 150^{\circ}\text{C}$.

*8 The suggested (minimum) strength of operation magnetic field component in the sensor plane is crucial for securing the minimum angular error as specified in note 9.

*9 $\Delta\theta = |\theta_{re} - \theta_{me}|$, where θ_{re} is real angle and θ_{me} is the angle measured by the sensor. The error rules out the contribution from bridge offset.

*10 $a_{sy} = 100 - 100 \times \frac{V_{PS}}{V_{PC}}$, where V_{PS} is signal amplitude from element S and V_{PC} is signal amplitude from element C.

4. Technology Overview

4.1. AMR Technology

IST8210, a high performance iSentek's angle sensor is designed based on anisotropy magneto-resistance (AMR) technology. AMR effect occurs in ferromagnetic (FM) materials, in which the electric resistance as a function of the angle between the directions of the magnetization of the FM material and electric current. When the magnetization parallel to the current direction, a maximum resistance appears; when they are orthogonal to each other, resistance reaches a minimum. The FM material used for IST8210 is Permalloy, which has excellent response to even the slightest external magnetic field change. iSentek's AMR sensors are manufactured in thin-film technology on a wafer. The production equipment, clean environment, and the process steps are similar to the CMOS chip manufacturing.

4.2. Advantages of AMR Technology

AMR technology has following advantages:

- High sensitivity and low noise
- High resolution
- High bandwidth
- Small footprint
- Compatibility of manufacturing process
- Excellent robustness
- Radiation resistant

A sensing element based on AMR technology shows high sensitivity and resolution, the sensitivity is about 50 to 200 times larger than conventional Hall element. The high sensitivity and resolution facilitate outstanding performances including high response speed, high accuracy, low noise, and low power consumption. Moreover, the manufacturing process is compatible to CMOS process, allowing the integration into IC production. The small footprint of the AMR sensor is flexible in integrating with other sensors or devices. Comparing to other sensing technology like GMR and TMR, the simple layer structure of AMR (less than 3 layers depending on specific recipe) provides excellent robustness especially against thermal-related impacts.

4.3. Features of IST8210

IST8210 contains two independent (galvanically isolated) full Wheatstone bridges arranged around the geometric center of the device. Each bridge generates sinusoidal output and sensitive only to the direction of the external magnetic field. The output generates from the resistance change of the AMR resistors while the direction of external magnetic field changes. The two bridges form an angle of 45° , creating a phase shift in signal, so that the function of the output would be $\sin(2\theta)$ and $\cos(2\theta)$. After conversion by arctangent, absolute angle could be obtained.

The AMR resistors in IST8210 have unique design, which is the key to achieve the best linearity and accuracy. The conventional AMR resistors are usually in rectangular shape having a long axis and short axis. When external magnetic field changes, magnetization of the AMR resistors rotates in response; however, the non-uniform shape anisotropy causes a distribution in magnetic polarization with rotation angle, giving rise to non-linearity of the output. The unique design of IST8210 successfully solves this issue, achieving an outstanding typical accuracy of 0.05° .

By combining a magnetic measuring scale, IST8210 together with an evaluation circuit can measure linear and rotary movements with high precision. IST8210 angle sensor is designed independent of the pole length (pitch) of the magnetic scale, providing maximum flexibility to user design.

4.4. Advantages of IST8210

IST8210 has advantages including:

- High accuracy and resolution
- Outstanding bandwidth and response speed
- Minimal bridge offset
- Low temperature coefficient of bridge offset
- Negligible magnetic hysteresis
- Non-contact and wear-free detection

- Allowing large working distance
- Insensitive to dust, water, oil, and other contaminations
- Excellent robustness against shocks and vibrations
- Low power consumption
- Wide operation temperature range
- Constant sensitivity at very high operation field

The high performance of IST8210 provides accurate and instant angle, position, traveling, or sensitive speed control. The minimum bridge offset voltage and negligible magnetic hysteresis of the sensor ensure the precision of measurement even with a simple evaluation circuits. The low temperature coefficient of both bridge offset and sensitivity allows the uses in a wide range of operation temperature without significant loss of accuracy. The operation range from -40°C to 150°C covers many automotive applications. Non-contact nature avoids interferences from environment such as dust, water, oil and from operation like wearing. IST8210 supports large working distance and is endurable to shocks and vibrations, offering flexibility for the integration into a system and extraordinary robustness. Distinct from conventional Hall angle sensors whose sensitivity always proportional to the strength of the operation magnetic field, IST8210 has a constant sensitivity at operation magnetic field exceeds the suggested value. This unique feature allows end users to use magnets with wide range of flux density without additional tuning of the evaluation circuits, which is usually necessary for Hall-based angle sensors.

5. Ordering Information

For more information on iSentek's magnetic sensors, please send an email to sales@isentek.com or visit our website at www.isentek.com.

6. Legal disclaimer

6.1. Warranty and Liability Disclaimer

iSentek Inc. guarantees the information in this datasheet. It is assumed that the specification is accurate and reliable. However, iSentek Inc. makes no warranties or claims regarding the accuracy or completeness of this information and takes no responsibility for the use of the information, nor does it convey any license under its patent rights or the rights of third parties.

iSentek Inc. shall not be liable for any consequential, incidental, indirect, or punitive damages (including, but not limited to, profit loss, business interruption, and further expenses related to the removal, replacement, or rework of any products).

6.2. Application Disclaimer

iSentek's products are unsuitable for life-critical and safety-critical applications. For the use of its products in such applications, iSentek disclaims all liability. The customer agrees to indemnify and hold iSentek harmless from and against all liabilities and losses.

6.3. Disclaimer Regarding Changes

iSentek reserves the right to modify the contents of this datasheet, including specifications and descriptions, at any time and without prior notice. This document supersedes all previously issued information.

Looking for pricing, stock, or lifecycle information?

Click below to explore more details on WIN SOURCE:

- [View iST8210 on WIN SOURCE](#)
- [Isentek Inc. Information](#)

Optimize Your Supply Chain with WIN SOURCE Solutions

- ✓ Global Sourcing Solution
- ✓ Obsolete Management
- ✓ Cost Control Management
- ✓ Shortage Management
- ✓ Alternative Solution
- ✓ Excess Inventory Management