



THE DATASHEET OF HSMA-C130



Data Sheet

Description

The HSMx-C130 ChipLEDs are designed specially for the membrane switch application. The request is to have as low as possible while retaining the footprint at the optimal size of a 0603 (1.6 x 0.8 mm) device. Apart from the membrane switch application, the HSMx-C130 is also suitable for use in applications where low height is required.

These chip-type LEDs utilize Aluminum Indium Gallium Phosphide (AlInGaP) material technology. The AlInGaP material has a very high luminous efficiency, capable of producing high light output over a wide range of drive currents.

Four different colors are available: amber, red, green, and orange. All parts are intensity binned and color binned (except for red color). They come in 8 mm conductive tape on a 7 inch diameter reel with 4000 units per reel which make them compatible for automatic placement.

Features

- High brightness AlInGaP material
- Small size with extremely low profile
- 0603 industry standard footprint with 0.35mm height
- Diffused optics
- Operating range of -40°C to 85°C
- Available in 4 colors
- Compatible with IR soldering
- Available in 8 mm conductive tape on 7" diameter reel
- Reel sealed in zip locked moisture barrier bags

Applications

- Membrane switch indicator
- LCD backlighting
- Push button backlighting
- Front panel indicator
- Symbol backlighting
- Keypad backlighting

CAUTION: HSMx-C130 LEDs are Class 1A ESD sensitive per JESD22-A114C.01 standard. Please observe appropriate precautions during handling and processing. Refer to Application Note AN-1142 for additional details.

Package Dimensions

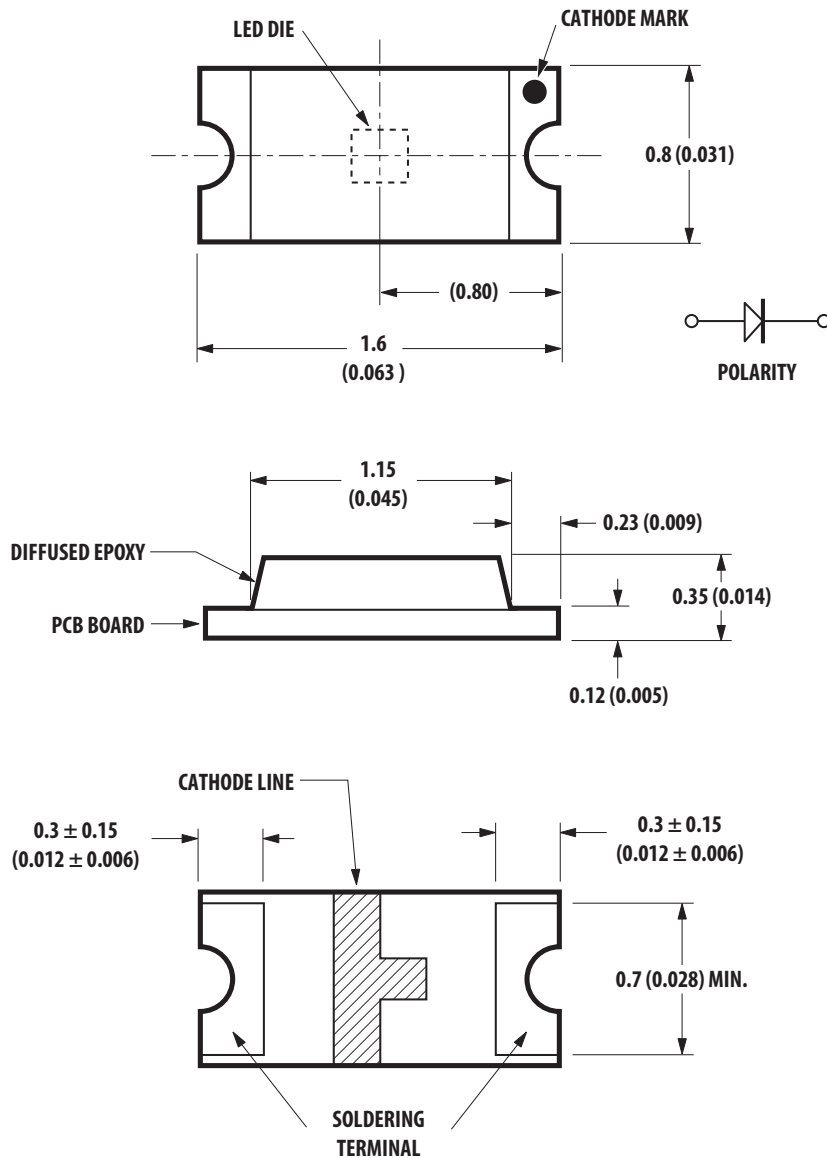

NOTES:

1. ALL DIMENSIONS IN MILLIMETERS (INCHES).
2. TOLERANCE IS ± 0.1 mm (± 0.004 IN.) UNLESS OTHERWISE SPECIFIED.

Device Selection Guide

Part Number	Color	Die Technology	Parts per Reel	Package Description
HSMA-C130	Amber	AllnGaP	4000	Untinted, Diffused
HSMC-C130	Red	AllnGaP	4000	Untinted, Diffused
HSME-C130	Yellow Green	AllnGaP	4000	Untinted, Diffused
HSML-C130	Orange	AllnGaP	4000	Untinted, Diffused

Absolute Maximum Ratings at $T_A = 25^\circ\text{C}$

Parameter	AllnGaP	Units
DC Forward Current ^[1]	20	mA
Power Dissipation	48	mW
Reverse Voltage ($I_R = 100\mu\text{A}$)	5	V
LED Junction Temperature	95	$^\circ\text{C}$
Operating Temperature Range	-40 to +85	$^\circ\text{C}$
Storage Temperature Range	-40 to +85	$^\circ\text{C}$
Soldering Temperature	See reflow soldering profile (Figure 5 & 6)	

Notes:

1. Derate linearly as shown in Figure 4.

Electrical Characteristics at $T_A = 25^\circ\text{C}$

Part Number	Forward Voltage V_F (Volts) @ $I_F = 20\text{mA}$		Reverse Breakdown V_R (Volts) @ $I_R = 100\mu\text{A}$	Thermal Resistance $R_{\theta_{JP}}$ ($^\circ\text{C}/\text{W}$) Typical
	Typ.	Max.	Min.	
HSMA-C130	2.05	2.40	5	500
HSMC-C130	1.94	2.40	5	500
HSME-C130	1.94	2.40	5	500
HSML-C130	1.94	2.40	5	500

Optical Characteristics at $T_A = 25^\circ\text{C}$

Part Number	Luminous Intensity I_V ^[1] (mcd) @ 20mA		Peak Wavelength λ_{peak} (nm) Typical	Color, Dominant Wavelength λ_d ^[2] (nm) Typical	Viewing Angle $2\theta_{1/2}$ ^[3] (Degrees) Typical
	Min.	Typ.			
HSMA-C130	28.5	87.0	591	589	110
HSMC-C130	28.5	131.0	635	626	110
HSME-C130	18.0	54.0	575	573	110
HSML-C130	28.5	139.0	612	606	110

Notes:

1. The luminous intensity I_V is measured at the peak of the spatial radiation pattern which may not be aligned with the mechanical axis of the LED package.
2. The dominant wavelength, λ_d are derived from the CIE Chromaticity Diagram and represents the perceived color of the device.
3. $\lambda_{1/2}$ is the off-axis angle where the luminous intensity is $1/2$ the peak intensity.

Light Intensity (IV) Bin Limits

Bin ID	Intensity (mcd)	
	Minimum	Maximum
M	18.00	28.50
N	28.50	45.00
P	45.00	71.50
Q	71.50	112.50
R	112.50	180.00

Tolerance : $\pm 15\%$

Notes:

1. Bin categories are established for classification of products. Products may not be available in all categories. Please contact your Avago representative for information on current available bins.

Forward Voltage Limits

Bin ID	Forward Voltage (V)	
	Minimum	Maximum
1	1.60	1.80
2	1.80	2.00
3	2.00	2.20
4	2.20	2.40

Tolerance : $\pm 0.1V$

AllnGaP Amber Color Bin Limits

Bin ID	Dominant Wavelength (nm)	
	Minimum	Maximum
A	582.0	584.5
B	584.5	587.0
C	587.0	589.5
D	589.5	592.0
E	592.0	594.5
F	594.5	597.0

Tolerance : $\pm 1nm$

AllnGaP Red Color Bin Limits

Bin ID	Dominant Wavelength (nm)	
	Minimum	Maximum
-	620.0	635.0

Tolerance : $\pm 1nm$

AllnGaP Yellow Green Color Bin Limits

Bin ID	Dominant Wavelength (nm)	
	Minimum	Maximum
A	561.5	564.5
B	564.5	567.5
C	567.5	570.5
D	570.5	573.5
E	573.5	576.5

Tolerance : $\pm 1nm$

AllnGaP Orange Color Bin Limits

Bin ID	Dominant Wavelength (nm)	
	Minimum	Maximum
A	597.0	600.0
B	600.0	603.0
C	603.0	606.0
D	606.0	609.0
E	609.0	612.0
F	612.0	615.0

Tolerance : $\pm 1nm$

Notes:

1. Bin categories are established for classification of products. Products may not be available in all categories. Please contact your Avago representative for information on current available bins.

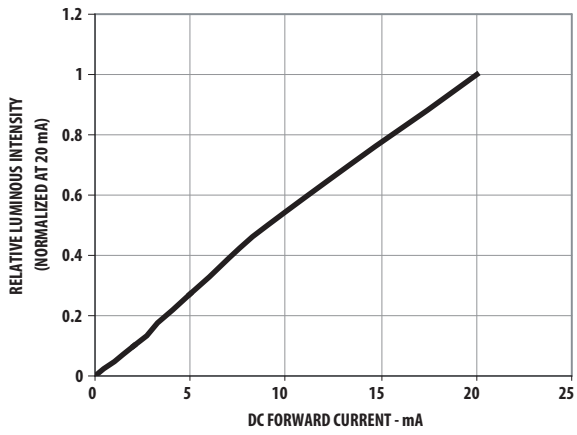

Figure 1. Luminous Intensity vs. Forward Current

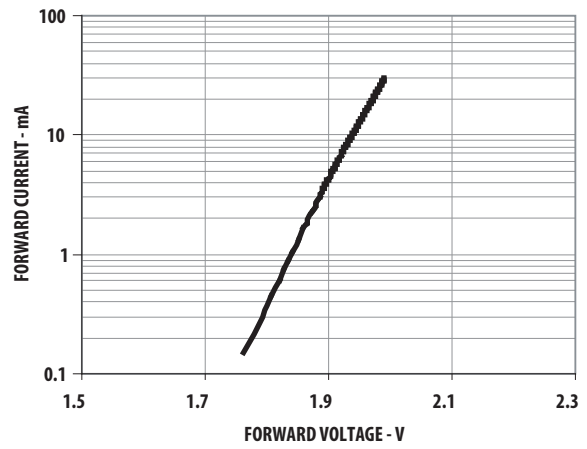

Figure 2. Forward Current vs. Forward Voltage

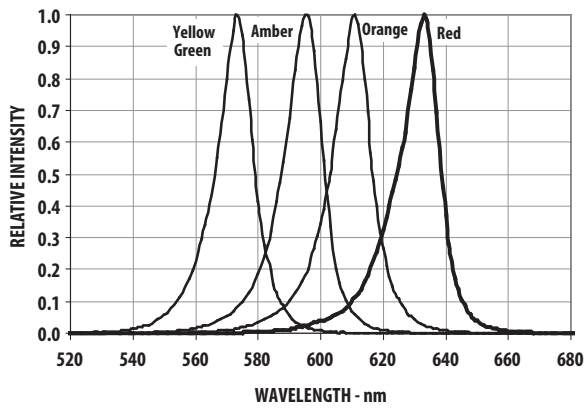

Figure 3. Relative Intensity vs. Peak Wavelength

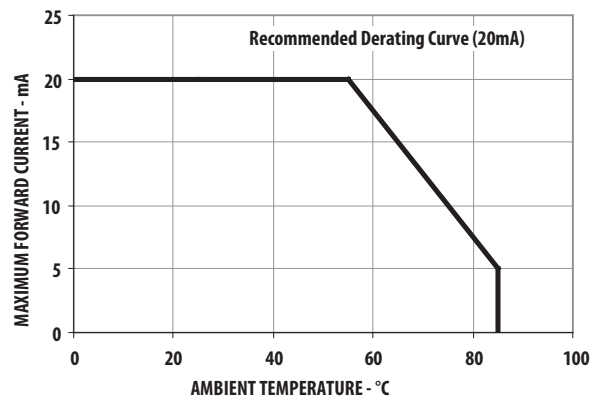

Figure 4. Maximum DC Forward Current vs. Ambient Temperature

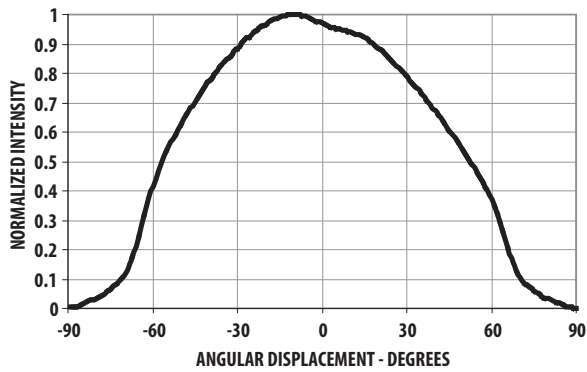

Figure 5. Radiation Pattern

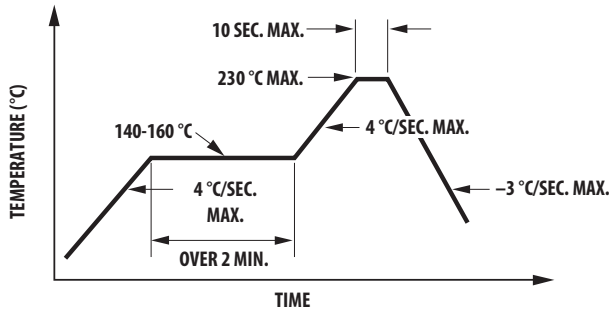

Figure 6. Recommended Lead Reflow Soldering Profile

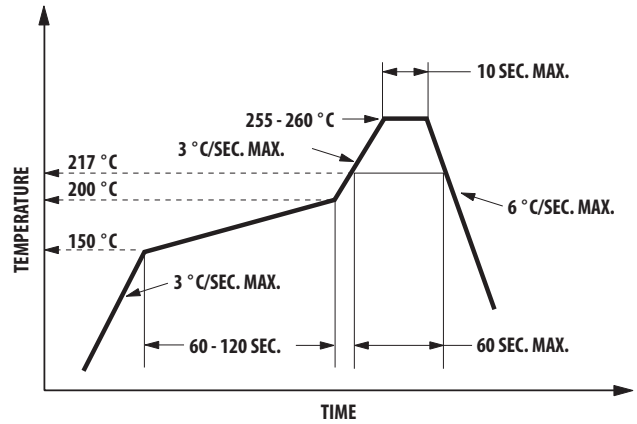

Figure 7. Recommended Pb Free Reflow Soldering Profile

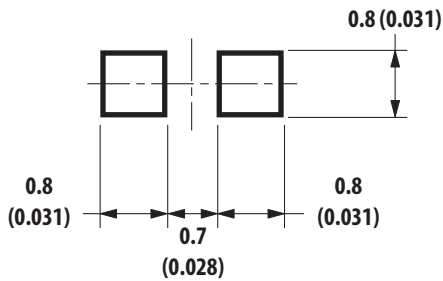

Figure 8. Recommended Soldering Land Pattern

Notes:

1. All dimensions are in millimeters (inches).
2. Tolerance is $\pm 0.1\text{mm}$ ($\pm 0.004\text{in.}$) unless otherwise specified.

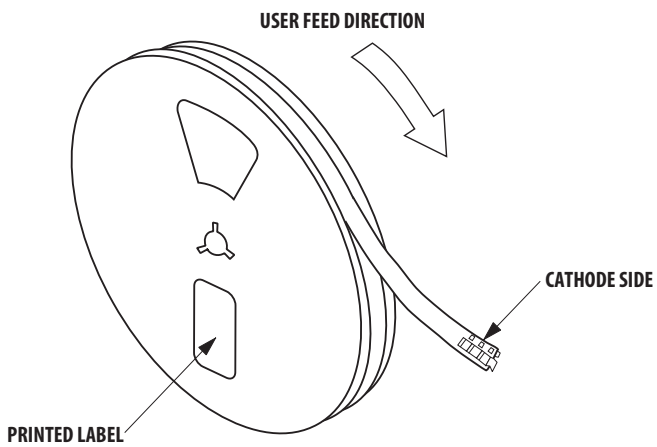

Figure 9. Reeling Orientation

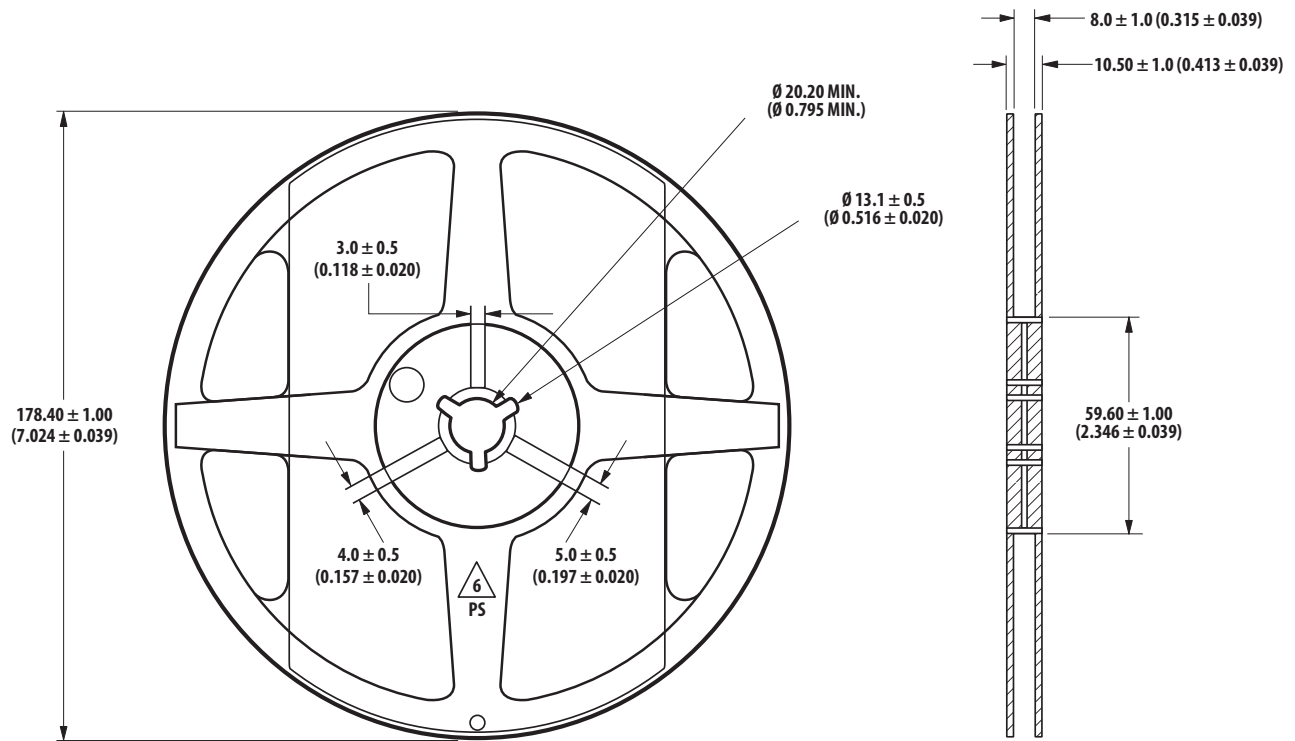

Figure 10. Reel Dimensions

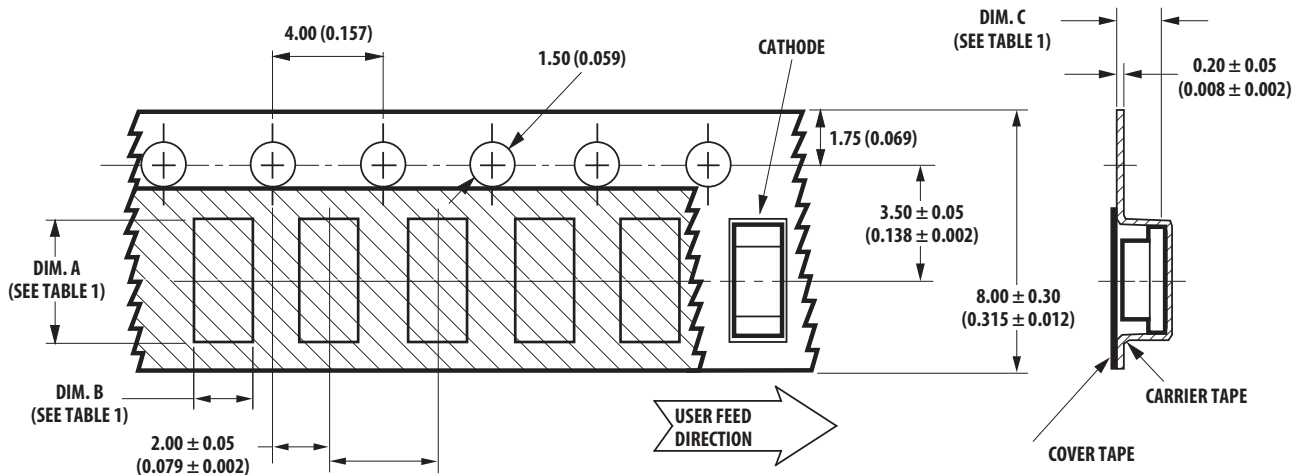

TABLE 1

PART NUMBER	DIM. A ± 0.10 (± 0.004)	DIM. B ± 0.10 (± 0.004)	DIM. C ± 0.10 (± 0.004)
HSMx-C130	1.75 (0.069)	0.90 (0.035)	0.60 (0.024)

DIMENSIONS IN MILLIMETERS (INCHES)

Figure 11. Tape Dimensions

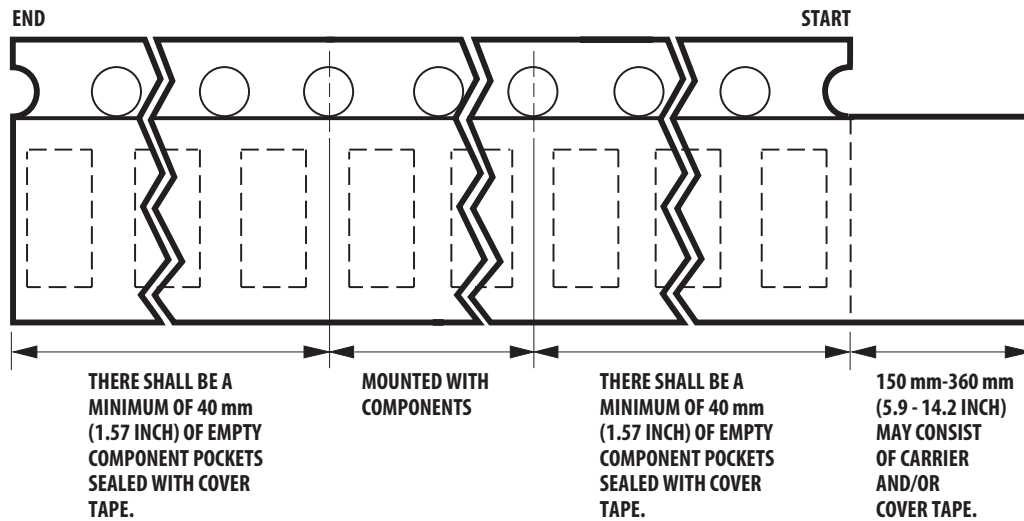

Figure 12. Tape leader and trailer dimensions

Reflow Soldering:

For more information on reflow soldering, refer to Application Note AN-1060, Surface Mounting SMT LED Indicator Components.

Storage Condition:

5 to 30°C @ 60%RH max.

Baking is required before mounting, if:

1. Humidity Indicator Card is > 10% when read at 23 ± 5°C.
2. Device expose to factory conditions <30°C/60%RH more than 168 hours.

Recommended baking condition:

60±5°C for 20 hours.

For product information and a complete list of distributors, please go to our web site: www.avagotech.com

Avago, Avago Technologies, and the A logo are trademarks of Avago Technologies in the United States and other countries. Data subject to change. Copyright © 2005-2010 Avago Technologies. All rights reserved. AV02-0484EN - November 23, 2010

Avago
TECHNOLOGIES

Looking for pricing, stock, or lifecycle information?

Click below to explore more details on WIN SOURCE:

 [View HSMA-C130 on WIN SOURCE](#)

 [Broadcom Limited](#) Information

Optimize Your Supply Chain with WIN SOURCE Solutions

-  Global Sourcing Solution
-  Obsolete Management
-  Cost Control Management
-  Shortage Management
-  Alternative Solution
-  Excess Inventory Management