



**THE DATASHEET OF
HT1MOA4S30/E/3J**



HT1x

HITAG 1 transponder IC

Rev. 3.1 — 10 December 2014
210531

Product short data sheet
COMPANY PUBLIC

1. General description

HITAG 1 based transponders are highly integrated and do not need any additional components beside the external coil.

Data between Key (RWD) and transponder is transmitted bidirectionally, in Half Duplex Mode. The HITAG 1 transponder IC offers also an encrypted data transmission.

The AntiCollision (AC) Mode, which is used mainly in long range operation, allows to handle several transponders that are at the same time in the communication field of the antenna, thus achieving highest operating reliability and permitting to handle several transponders quickly and simultaneously.

The HITAG 1 transponder IC provides two protocol modes, Standard and Advanced Mode. The Advanced Protocol Mode operates compared to the Standard Protocol Mode with an increased number of Startbits and a 8-bit Cyclic Redundancy Check (CRC) sent by the transponder IC at read operations.

HITAG 1 transponder IC offer a memory of 2 kbit.

2. Features and benefits

- Identification transponder for use in contactless applications
- Operating frequency 125 kHz
- Data transmission and energy supply via RF link, no internal battery
- Non-volatile memory of 2 kbit
- Organized in 64 pages, 4 bytes each
- 10 years non-volatile data retention
- 100000 erase/write cycles
- Selective read/write protection of memory content
- Mutual authentication function

3. Applications

- Logistics
- Asset tracking
- Gas cylinder ID
- Industrial automation



4. Quick reference data

Table 1. Quick reference data

Symbol	Parameter	Conditions	Min	Typ	Max	Unit
Wafer EEPROM characteristics						
t_{ret}	retention time	$T_{\text{amb}} \leq 55 \text{ }^\circ\text{C}$	10	-	-	year
$N_{\text{endu(W)}}$	write endurance		100000	-	-	cycle
Interface characteristics						
C_i	input capacitance	between LA and LB HT1ICS3002W/V6F	189	210	231	pF

5. Ordering information

Table 2. Ordering information

Type number	Package		
	Name	Description	Version
HT1ICS3002W/V6F	Wafer	sawn wafer on FFC, 150 μm , 8 inch, UV, inkless	-
HT1MOA4S30/E/3	PLLMC	plastic leadless module carrier package; 35 mm wide tape	SOT500-2 ^[1]

[1] This package is also known as MOA4

6. Block diagram

The HITAG 1 transponder IC requires no external power supply. The contactless interface generates the power supply and the system clock via the resonant circuitry by inductive coupling to the RWD. The interface also demodulates data transmitted from the RWD to the HITAG 1 transponder IC, and modulates the magnetic field for data transmission from the HITAG 1 transponder IC to the RWD.

Data are stored in a non-volatile memory (EEPROM). The memory has a capacity of 2 kbit and is organized in blocks.

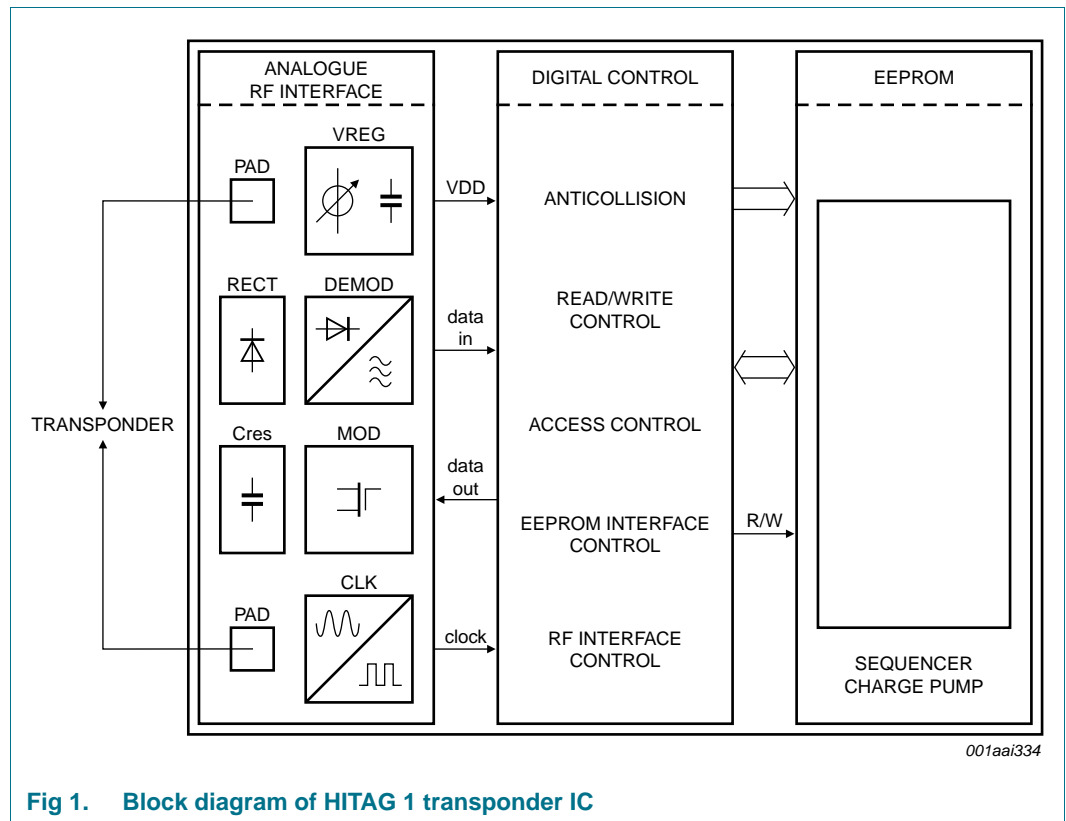

Fig 1. Block diagram of HITAG 1 transponder IC

7. Functional description

7.1 Memory map

The 2 kbit memory area of the HITAG 1 transponder IC is divided into 16 blocks. Each block comprises 4 pages with 4 bytes (1 byte = 8 bits) each. A page is the smallest access unit.

Addressing is done pagewise (page 0 to 63) whereas access is gained either pagewise or blockwise by entering the respective start address.

Block access is only available for blocks 2 to 15, page access is available for pages 0 to 63.

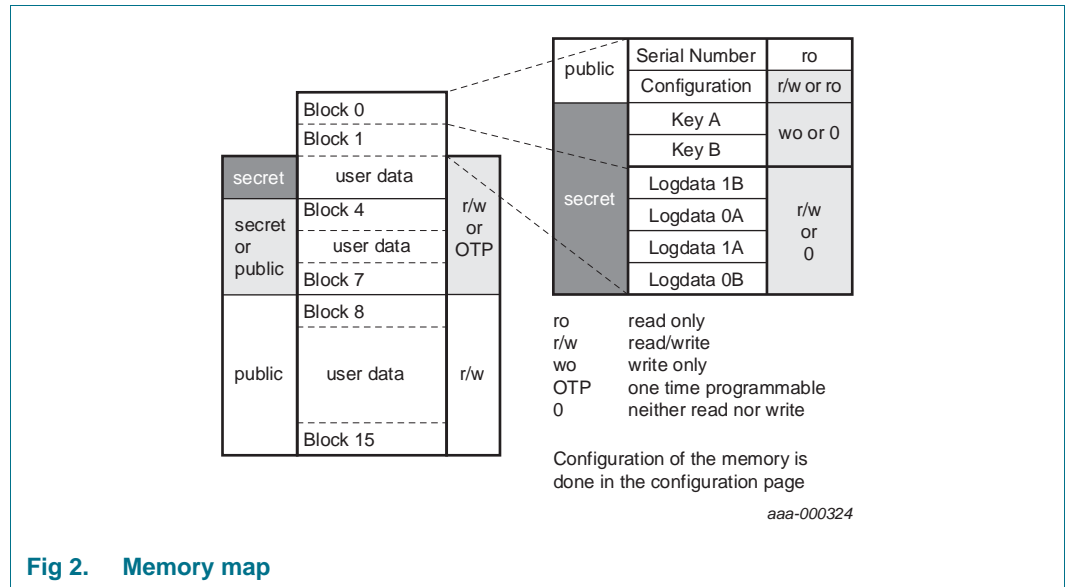

Fig 2. Memory map

Areas (or settings) with light dark background can be configured by the customer within the Configuration Page (page 1 of block 0).

8. Limiting values

Table 3. Limiting values - HT1ICS3002W/V6F^[1]

Symbol	Parameter	Conditions	Min	Max	Unit
V _{DD}	supply voltage		-0.5	6.5	V
V _{ESD}	electrostatic discharge voltage	MIL-STD 883D, Method 3015.7, Human Body	2	-	kV
I _{lu}	latch-up current	MIL-STD 883D, Method 3023	100	-	mA
I _{i(max)}	maximum input current	IN1-IN2	-	30	mA
T _j	junction temperature		-55	+140	°C

[1] Stresses above those listed under Absolute Maximum Ratings may cause permanent damage to the device. This is a stress rating only and functional operation of the device at these or any conditions other than those described in the Operating Conditions and Electrical Characteristics section of this specification is not implied.

Table 4. Limiting values - HT1MOA4S30^[1]

Symbol	Parameter	Conditions	Min	Max	Unit
T _{stg}	storage temperature		-55	+125	°C
T _{amb}	ambient temperature	R _{th(j-a)} ≤ 30 K/W @ I _{in} = 30 mA	-25	+85	°C

[1] Stresses above those listed under Absolute Maximum Ratings may cause permanent damage to the device. This is a stress rating only and functional operation of the device at these or any conditions other than those described in the Operating Conditions and Electrical Characteristics section of this specification is not implied.

9. Abbreviations

Table 5. Abbreviations

Acronym	Description
AC	AntiCollision
CRC	Cyclic Redundancy Check
EEPROM	Electrically Erasable Programmable Read-Only Memory
IC	Integrated Circuit
RF	Radio Frequency
RWD	Read Write Device

10. Revision history

Table 6. Revision history

Document ID	Release date	Data sheet status	Change notice	Supersedes
HT1X_SDS v.3.1	20141210	Product short data sheet	-	HT1X_SDS v.3.0
Modifications:	<ul style="list-style-type: none">• Section 11 “Legal information”: License statement “ICs with HITAG functionality” removed• Section 5 “Ordering information”: updated• Table 4: Title updated			
HT1X_SDS v.3.0	20110916	Product short data sheet	-	-

11. Legal information

11.1 Data sheet status

Document status ^{[1][2]}	Product status ^[3]	Definition
Objective [short] data sheet	Development	This document contains data from the objective specification for product development.
Preliminary [short] data sheet	Qualification	This document contains data from the preliminary specification.
Product [short] data sheet	Production	This document contains the product specification.

[1] Please consult the most recently issued document before initiating or completing a design.

[2] The term 'short data sheet' is explained in section "Definitions".

[3] The product status of device(s) described in this document may have changed since this document was published and may differ in case of multiple devices. The latest product status information is available on the Internet at URL <http://www.nxp.com>.

11.2 Definitions

Draft — The document is a draft version only. The content is still under internal review and subject to formal approval, which may result in modifications or additions. NXP Semiconductors does not give any representations or warranties as to the accuracy or completeness of information included herein and shall have no liability for the consequences of use of such information.

Short data sheet — A short data sheet is an extract from a full data sheet with the same product type number(s) and title. A short data sheet is intended for quick reference only and should not be relied upon to contain detailed and full information. For detailed and full information see the relevant full data sheet, which is available on request via the local NXP Semiconductors sales office. In case of any inconsistency or conflict with the short data sheet, the full data sheet shall prevail.

Product specification — The information and data provided in a Product data sheet shall define the specification of the product as agreed between NXP Semiconductors and its customer, unless NXP Semiconductors and customer have explicitly agreed otherwise in writing. In no event however, shall an agreement be valid in which the NXP Semiconductors product is deemed to offer functions and qualities beyond those described in the Product data sheet.

11.3 Disclaimers

Limited warranty and liability — Information in this document is believed to be accurate and reliable. However, NXP Semiconductors does not give any representations or warranties, expressed or implied, as to the accuracy or completeness of such information and shall have no liability for the consequences of use of such information. NXP Semiconductors takes no responsibility for the content in this document if provided by an information source outside of NXP Semiconductors.

In no event shall NXP Semiconductors be liable for any indirect, incidental, punitive, special or consequential damages (including - without limitation - lost profits, lost savings, business interruption, costs related to the removal or replacement of any products or rework charges) whether or not such damages are based on tort (including negligence), warranty, breach of contract or any other legal theory.

Notwithstanding any damages that customer might incur for any reason whatsoever, NXP Semiconductors' aggregate and cumulative liability towards customer for the products described herein shall be limited in accordance with the *Terms and conditions of commercial sale* of NXP Semiconductors.

Right to make changes — NXP Semiconductors reserves the right to make changes to information published in this document, including without limitation specifications and product descriptions, at any time and without notice. This document supersedes and replaces all information supplied prior to the publication hereof.

Suitability for use — NXP Semiconductors products are not designed, authorized or warranted to be suitable for use in life support, life-critical or safety-critical systems or equipment, nor in applications where failure or malfunction of an NXP Semiconductors product can reasonably be expected to result in personal injury, death or severe property or environmental damage. NXP Semiconductors and its suppliers accept no liability for inclusion and/or use of NXP Semiconductors products in such equipment or applications and therefore such inclusion and/or use is at the customer's own risk.

Applications — Applications that are described herein for any of these products are for illustrative purposes only. NXP Semiconductors makes no representation or warranty that such applications will be suitable for the specified use without further testing or modification.

Customers are responsible for the design and operation of their applications and products using NXP Semiconductors products, and NXP Semiconductors accepts no liability for any assistance with applications or customer product design. It is customer's sole responsibility to determine whether the NXP Semiconductors product is suitable and fit for the customer's applications and products planned, as well as for the planned application and use of customer's third party customer(s). Customers should provide appropriate design and operating safeguards to minimize the risks associated with their applications and products.

NXP Semiconductors does not accept any liability related to any default, damage, costs or problem which is based on any weakness or default in the customer's applications or products, or the application or use by customer's third party customer(s). Customer is responsible for doing all necessary testing for the customer's applications and products using NXP Semiconductors products in order to avoid a default of the applications and the products or of the application or use by customer's third party customer(s). NXP does not accept any liability in this respect.

Limiting values — Stress above one or more limiting values (as defined in the Absolute Maximum Ratings System of IEC 60134) will cause permanent damage to the device. Limiting values are stress ratings only and (proper) operation of the device at these or any other conditions above those given in the Recommended operating conditions section (if present) or the Characteristics sections of this document is not warranted. Constant or repeated exposure to limiting values will permanently and irreversibly affect the quality and reliability of the device.

Terms and conditions of commercial sale — NXP Semiconductors products are sold subject to the general terms and conditions of commercial sale, as published at <http://www.nxp.com/profile/terms>, unless otherwise agreed in a valid written individual agreement. In case an individual agreement is concluded only the terms and conditions of the respective agreement shall apply. NXP Semiconductors hereby expressly objects to applying the customer's general terms and conditions with regard to the purchase of NXP Semiconductors products by customer.

No offer to sell or license — Nothing in this document may be interpreted or construed as an offer to sell products that is open for acceptance or the grant, conveyance or implication of any license under any copyrights, patents or other industrial or intellectual property rights.

Export control — This document as well as the item(s) described herein may be subject to export control regulations. Export might require a prior authorization from competent authorities.

Quick reference data — The Quick reference data is an extract of the product data given in the Limiting values and Characteristics sections of this document, and as such is not complete, exhaustive or legally binding.

Non-automotive qualified products — Unless this data sheet expressly states that this specific NXP Semiconductors product is automotive qualified, the product is not suitable for automotive use. It is neither qualified nor tested in accordance with automotive testing or application requirements. NXP Semiconductors accepts no liability for inclusion and/or use of non-automotive qualified products in automotive equipment or applications.

In the event that customer uses the product for design-in and use in automotive applications to automotive specifications and standards, customer (a) shall use the product without NXP Semiconductors' warranty of the

product for such automotive applications, use and specifications, and (b) whenever customer uses the product for automotive applications beyond NXP Semiconductors' specifications such use shall be solely at customer's own risk, and (c) customer fully indemnifies NXP Semiconductors for any liability, damages or failed product claims resulting from customer design and use of the product for automotive applications beyond NXP Semiconductors' standard warranty and NXP Semiconductors' product specifications.

11.4 Trademarks

Notice: All referenced brands, product names, service names and trademarks are the property of their respective owners.

HITAG — is a trademark of NXP Semiconductors N.V.

12. Contact information

For more information, please visit: <http://www.nxp.com>

For sales office addresses, please send an email to: salesaddresses@nxp.com

13. Contents

1	General description	1
2	Features and benefits	1
3	Applications	1
4	Quick reference data	2
5	Ordering information	2
6	Block diagram	3
7	Functional description	4
7.1	Memory map	4
8	Limiting values	5
9	Abbreviations	5
10	Revision history	6
11	Legal information	7
11.1	Data sheet status	7
11.2	Definitions	7
11.3	Disclaimers	7
11.4	Trademarks	8
12	Contact information	8
13	Contents	9

Please be aware that important notices concerning this document and the product(s) described herein, have been included in section 'Legal information'.

© NXP B.V. 2014.

All rights reserved.

For more information, please visit: <http://www.nxp.com>

For sales office addresses, please send an email to: salesaddresses@nxp.com

Date of release: 10 December 2014
210531

Looking for pricing, stock, or lifecycle information?

Click below to explore more details on WIN SOURCE:

 [View HT1MOA4S30/E/3J on WIN SOURCE](#)

 [NXP / Nexperia Information](#)

Optimize Your Supply Chain with WIN SOURCE Solutions

-  Global Sourcing Solution
-  Obsolete Management
-  Cost Control Management
-  Shortage Management
-  Alternative Solution
-  Excess Inventory Management