



**THE DATASHEET OF
CY7C1041BNV33L-12VXC**



Features

- High speed
 - $t_{AA} = 12$ ns
- Low active power
 - 612 mW (max.)
- Low CMOS standby power
 - 1.8 mW (max.)
- 2.0 V Data Retention (660 μ W at 2.0 V retention)
- Automatic power-down when deselected
- TTL-compatible inputs and outputs
- Easy memory expansion with \overline{CE} and \overline{OE} features

Functional Description

The CY7C1041BNV33 is a high-performance CMOS Static RAM organized as 262,144 words by 16 bits.

Writing to the device is accomplished by taking Chip Enable (\overline{CE}) and Write Enable (\overline{WE}) inputs LOW. If Byte Low Enable (\overline{BLE}) is LOW, then data from I/O pins (I/O₀ through I/O₇), is written into the location specified on the address pins (A₀ through A₁₇). If Byte High Enable (\overline{BHE}) is LOW, then data from I/O pins (I/O₈ through I/O₁₅) is written into the location specified on the address pins (A₀ through A₁₇).

Reading from the device is accomplished by taking Chip Enable (\overline{CE}) and Output Enable (\overline{OE}) LOW while forcing the Write Enable (\overline{WE}) HIGH. If Byte Low Enable (\overline{BLE}) is LOW, then data from the memory location specified by the address pins will appear on I/O₀ to I/O₇. If Byte High Enable (\overline{BHE}) is LOW, then data from memory will appear on I/O₈ to I/O₁₅. See the truth table at the back of this data sheet for a complete description of read and write modes.

The input/output pins (I/O₀ through I/O₁₅) are placed in a high-impedance state when the device is deselected (\overline{CE} HIGH), the outputs are disabled (\overline{OE} HIGH), the BHE and \overline{BLE} are disabled (\overline{BHE} , \overline{BLE} HIGH), or during a write operation (\overline{CE} LOW, and \overline{WE} LOW).

The CY7C1041BNV33 is available in a standard 44-pin 400-mil-wide body width SOJ and 44-pin TSOP II package with center power and ground (revolutionary) pinout.

Logic Block Diagram

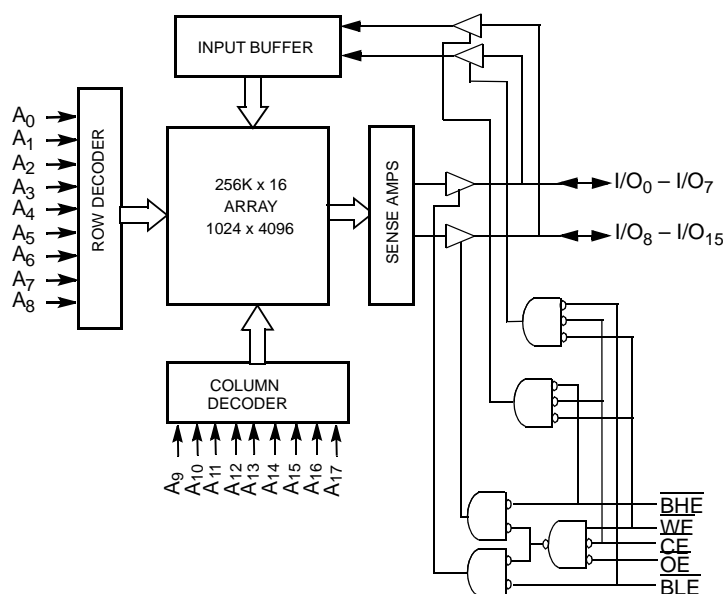

Contents

Pin Configuration	3	Truth Table	9
Selection Guide	3	Write Cycle No. 3 (\overline{WE} Controlled, \overline{OE} LOW)	9
Maximum Ratings	4	Ordering Information	10
Operating Range	4	Ordering Code Definitions	10
Electrical Characteristics	4	Package Diagrams	11
Capacitance	4	Acronyms	12
AC Test Loads and Waveforms	4	Document Conventions	12
Switching Characteristics	5	Units of Measure	12
Data Retention Characteristics	6	Document History Page	13
Data Retention Waveform	6	Sales, Solutions, and Legal Information	14
Switching Waveforms	7	Worldwide Sales and Design Support	14
Read Cycle No. 1	7	Products	14
Read Cycle No. 2 (\overline{OE} Controlled)	7	PSoC Solutions	14
Write Cycle No. 1 (\overline{CE} Controlled)	8		
Write Cycle No. 2 (BLE or BHE Controlled)	8		

Pin Configuration

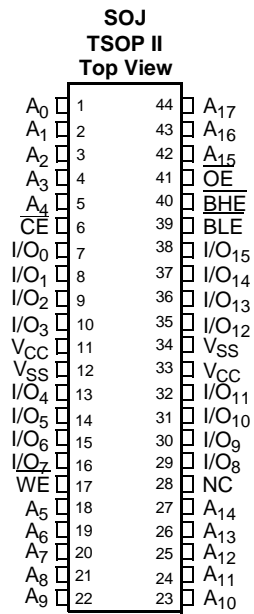

Selection Guide

		-12
Maximum Access Time (ns)		12
Maximum Operating Current (mA)	Commercial	190
Maximum CMOS Standby Current (mA)	Commercial	0.5

Maximum Ratings

Exceeding the maximum ratings may impair the useful life of the device. These user guidelines are not tested.

- Storage Temperature -65 °C to +150 °C
- Ambient Temperature with Power Applied -55 °C to +125 °C
- Supply Voltage on V_{CC} to Relative GND^[1] ... -0.5 V to +4.6 V

- DC Voltage Applied to Outputs in High Z State^[1] -0.5 V to V_{CC} + 0.5 V
- DC Input Voltage^[1] -0.5 V to V_{CC} + 0.5 V
- Current into Outputs (LOW) 20 mA

Operating Range

Range	Ambient Temperature ^[2]	V _{CC}
Commercial	0 °C to +70 °C	3.3 V ± 0.3 V

Electrical Characteristics

Over the Operating Range

Parameter	Description	Test Conditions	-12		Unit
			Min	Max	
V _{OH}	Output HIGH Voltage	V _{CC} = Min, I _{OH} = -4.0 mA	2.4	-	V
V _{OL}	Output LOW Voltage	V _{CC} = Min, I _{OL} = 8.0 mA	-	0.4	V
V _{IH}	Input HIGH Voltage		2.2	V _{CC} + 0.5	V
V _{IL}	Input LOW Voltage ^[1]		-0.5	0.8	V
I _{IX}	Input Leakage Current	GND ≤ V _I ≤ V _{CC}	-1	+1	µA
I _{OZ}	Output Leakage Current	GND ≤ V _{OUT} ≤ V _{CC} , Output Disabled	-1	+1	µA
I _{CC}	V _{CC} Operating Supply Current	V _{CC} = Max., f = f _{MAX} = 1/t _{RC}	Commercial	-	190 mA
I _{SB1}	Automatic CE Power-Down Current —TTL Inputs	Max. V _{CC} , $\overline{CE} \geq V_{IH}$, V _{IN} ≥ V _{IH} or V _{IN} ≤ V _{IL} , f = f _{MAX}	-	40	mA
I _{SB2}	Automatic CE Power-Down Current —CMOS Inputs	Max. V _{CC} , $\overline{CE} \geq V_{CC} - 0.3V$, V _{IN} ≥ V _{CC} - 0.3V, or V _{IN} ≤ 0.3V, f = 0	Commercial	-	0.5 mA

Capacitance^[3]

Parameter	Description	Test Conditions	Max	Unit
C _{IN}	Input Capacitance	T _A = 25 °C, f = 1 MHz, V _{CC} = 3.3 V	8	pF
C _{OUT}	I/O Capacitance		8	pF

AC Test Loads and Waveforms

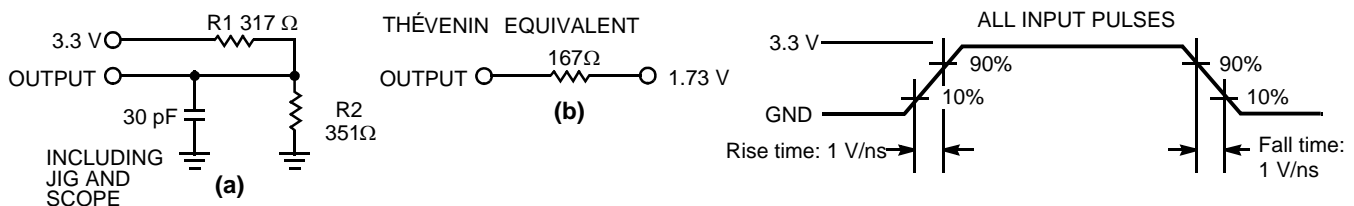

Notes

1. V_{IL} (min.) = -2.0 V for pulse durations of less than 20 ns.
2. T_A is the "Instant On" case temperature.
3. Tested initially and after any design or process changes that may affect these parameters.

Switching Characteristics^[4]

Over the Operating Range

Parameter	Description	-12		Unit
		Min	Max	
READ CYCLE				
t_{RC}	Read Cycle Time	12	–	ns
t_{AA}	Address to Data Valid	–	12	ns
t_{OHA}	Data Hold from Address Change	3	–	ns
t_{ACE}	\overline{CE} LOW to Data Valid	–	12	ns
t_{DOE}	\overline{OE} LOW to Data Valid	–	6	ns
t_{LZOE}	\overline{OE} LOW to Low Z	0	–	ns
t_{HZOE}	\overline{OE} HIGH to High Z ^[5, 6]	–	6	ns
t_{LZCE}	\overline{CE} LOW to Low Z ^[6]	3	–	ns
t_{HZCE}	\overline{CE} HIGH to High Z ^[5, 6]	–	6	ns
t_{PU}	\overline{CE} LOW to Power-Up	0	–	ns
t_{PD}	\overline{CE} HIGH to Power-Down	–	12	ns
t_{DBE}	Byte Enable to Data Valid	–	6	ns
t_{LZBE}	Byte Enable to Low Z	0	–	ns
t_{HZBE}	Byte Disable to High Z	–	6	ns
WRITE CYCLE^[7, 8]				
t_{WC}	Write Cycle Time	12	–	ns
t_{SCE}	\overline{CE} LOW to Write End	10	–	ns
t_{AW}	Address Set-Up to Write End	10	–	ns
t_{HA}	Address Hold from Write End	0	–	ns
t_{SA}	Address Set-Up to Write Start	0	–	ns
t_{PWE}	\overline{WE} Pulse Width	10	–	ns
t_{SD}	Data Set-Up to Write End	7	–	ns
t_{HD}	Data Hold from Write End	0	–	ns
t_{LZWE}	\overline{WE} HIGH to Low Z ^[6]	3	–	ns
t_{HZWE}	\overline{WE} LOW to High Z ^[5, 6]	–	6	ns
t_{BW}	Byte Enable to End of Write	10	–	ns

Notes

- Test conditions assume signal transition time of 3 ns or less, timing reference levels of 1.5 V, input pulse levels of 0 to 3.0 V, and output loading of the specified I_{OL}/I_{OH} and 30-pF load capacitance.
- t_{HZOE} , t_{HZCE} , and t_{HZWE} are specified with a load capacitance of 5 pF as in part (b) of [AC Test Loads and Waveforms on page 4](#). Transition is measured ± 500 mV from steady-state voltage.
- At any given temperature and voltage condition, t_{HZCE} is less than t_{LZCE} , t_{HZOE} is less than t_{LZOE} , and t_{HZWE} is less than t_{LZWE} for any given device.
- The internal write time of the memory is defined by the overlap of \overline{CE} LOW, and \overline{WE} LOW. \overline{CE} and \overline{WE} must be LOW to initiate a write, and the transition of either of these signals can terminate the write. The input data set-up and hold timing should be referenced to the leading edge of the signal that terminates the write.
- The minimum write cycle time for Write Cycle No. 3 (\overline{WE} controlled, \overline{OE} LOW) is the sum of t_{HZWE} and t_{SD} .

Data Retention Characteristics

Over the Operating Range

Parameter	Description	Conditions ^[9]	Min	Max	Unit
V_{DR}	V_{CC} for Data Retention		2.0	–	V
I_{CCDR}	Data Retention Current	$V_{CC} = V_{DR} = 2.0\text{ V}$, $\overline{CE} \geq V_{CC} - 0.3\text{ V}$, $V_{IN} \geq V_{CC} - 0.3\text{ V}$ or $V_{IN} \leq 0.3\text{ V}$	–	330	μA
$t_{CDR}^{[10]}$	Chip Deselect to Data Retention Time		0	–	ns
$t_R^{[11]}$	Operation Recovery Time		t_{RC}	–	ns

Data Retention Waveform

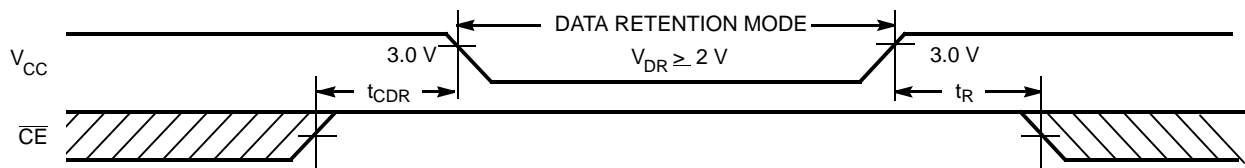

Notes

9. No input may exceed $V_{CC} + 0.5\text{ V}$.
10. Tested initially and after any design or process changes that may affect these parameters.
11. $t_r \leq 3\text{ ns}$ for the -12 and -15 speeds.

Switching Waveforms

Read Cycle No. 1^[12, 13]

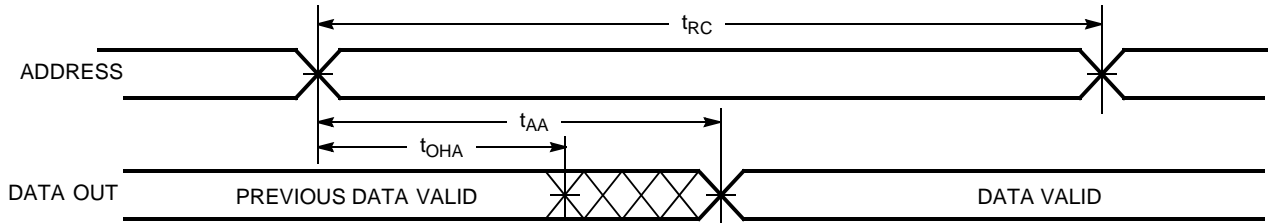

Read Cycle No. 2 ($\overline{\text{OE}}$ Controlled)^[13, 14]

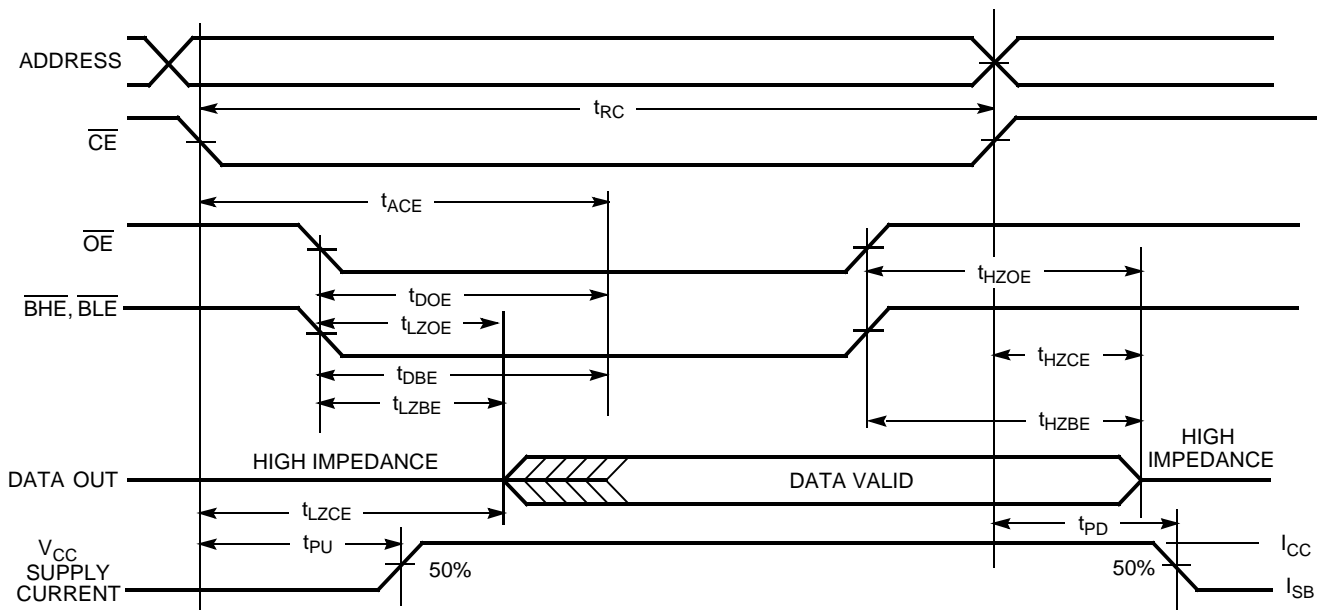

Notes

- 12. Device is continuously selected. $\overline{\text{OE}}$, $\overline{\text{CE}}$, $\overline{\text{BHE}}$ and/or $\overline{\text{BHE}} = V_{IL}$.
- 13. $\overline{\text{WE}}$ is HIGH for read cycle.
- 14. Address valid prior to or coincident with $\overline{\text{CE}}$ transition LOW.

Switching Waveforms (continued)

Write Cycle No. 1 ($\overline{\text{CE}}$ Controlled)^[15, 16]

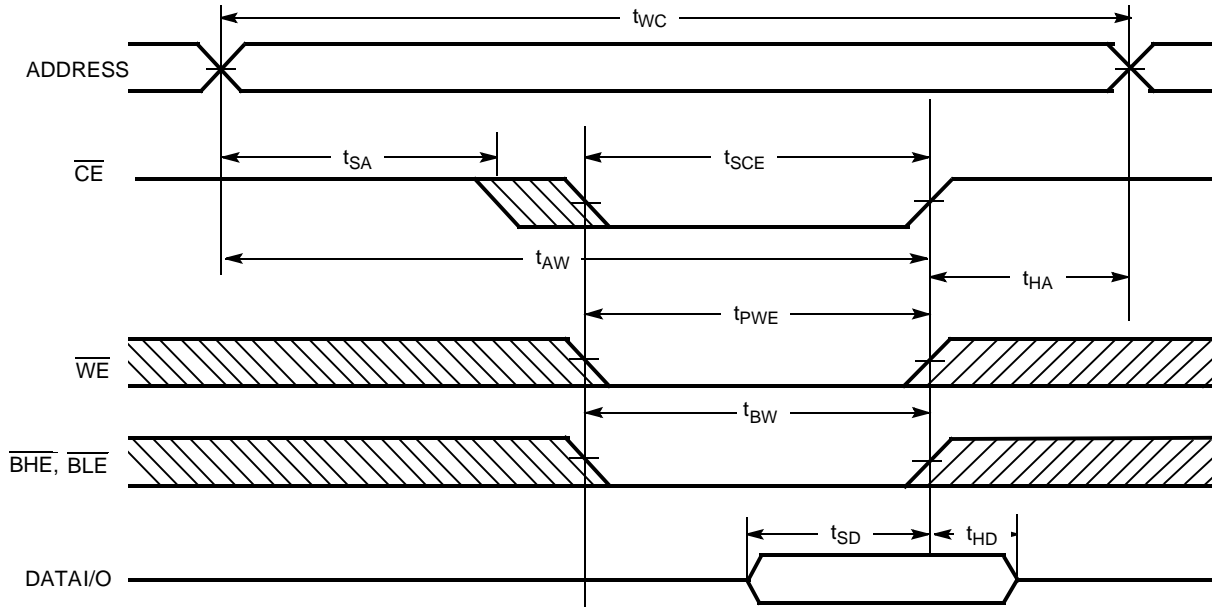

Write Cycle No. 2 ($\overline{\text{BLE}}$ or $\overline{\text{BHE}}$ Controlled)

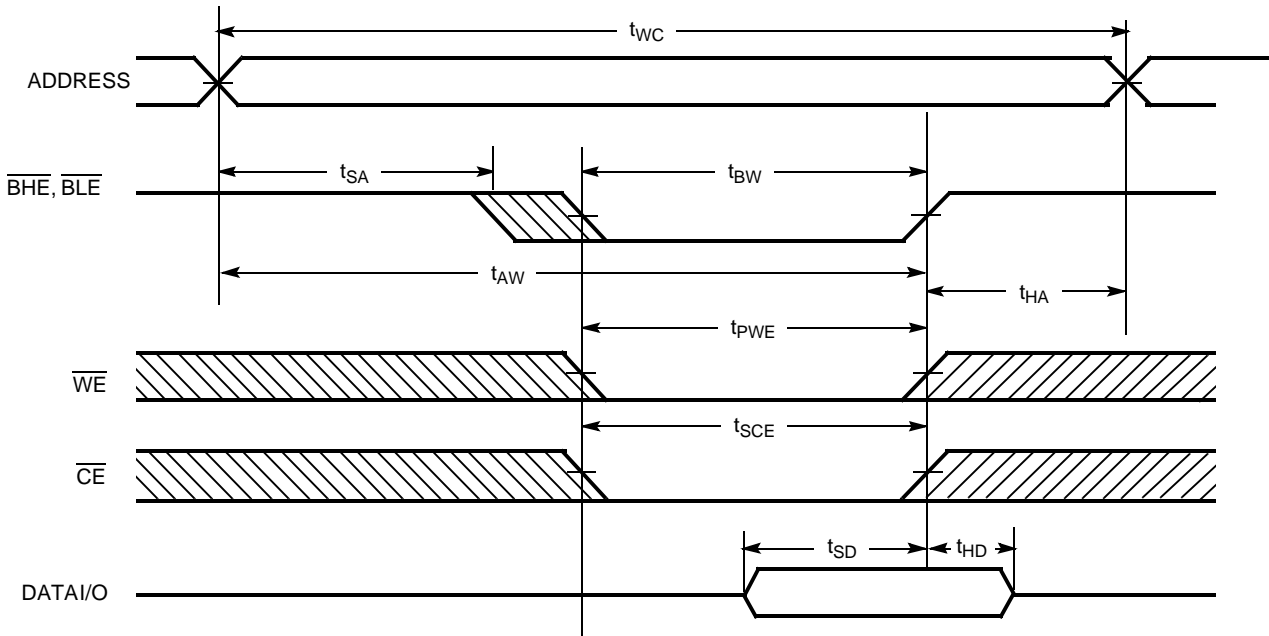

Notes

- 15. Data I/O is high-impedance if $\overline{\text{OE}}$ or $\overline{\text{BHE}}$ and/or $\overline{\text{BLE}} = V_{IH}$.
- 16. If $\overline{\text{CE}}$ goes HIGH simultaneously with WE going HIGH, the output remains in a high-impedance state.

Switching Waveforms (continued)

Write Cycle No. 3 (\overline{WE} Controlled, \overline{OE} LOW)

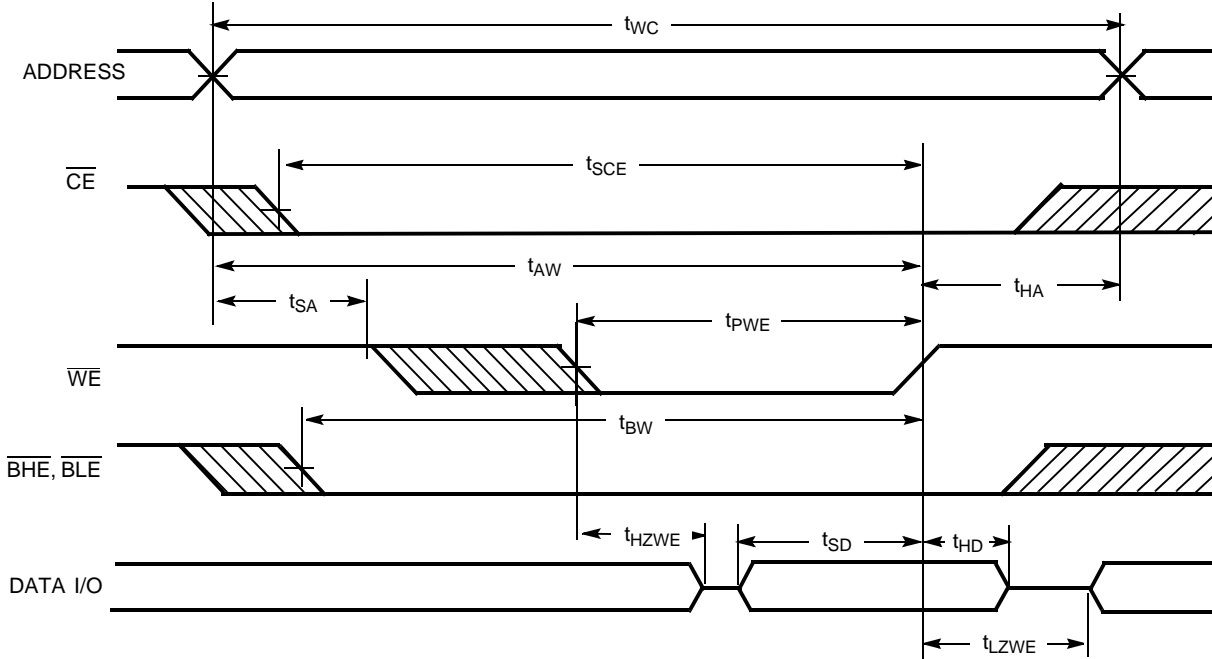

Truth Table

\overline{CE}	\overline{OE}	\overline{WE}	\overline{BLE}	\overline{BHE}	I/O ₀ -I/O ₇	I/O ₈ -I/O ₁₅	Mode	Power
H	X	X	X	X	High Z	High Z	Power Down	Standby (I_{SB})
L	L	H	L	L	Data Out	Data Out	Read All Bits	Active (I_{CC})
L	L	H	L	H	Data Out	High Z	Read Lower Bits Only	Active (I_{CC})
L	L	H	H	L	High Z	Data Out	Read Upper Bits Only	Active (I_{CC})
L	X	L	L	L	Data In	Data In	Write All Bits	Active (I_{CC})
L	X	L	L	H	Data In	High Z	Write Lower Bits Only	Active (I_{CC})
L	X	L	H	L	High Z	Data In	Write Upper Bits Only	Active (I_{CC})
L	H	H	X	X	High Z	High Z	Selected, Outputs Disabled	Active (I_{CC})

Ordering Information

Speed (ns)	Ordering Code	Package Diagram	Package Type	Operating Range
12	CY7C1041BNV33L-12VXC	51-85082	44-pin (400-Mil) Molded SOJ (Pb-free)	Commercial
	CY7C1041BNV33L-12ZXC	51-85087	44-pin TSOP II (Pb-free)	

Ordering Code Definitions

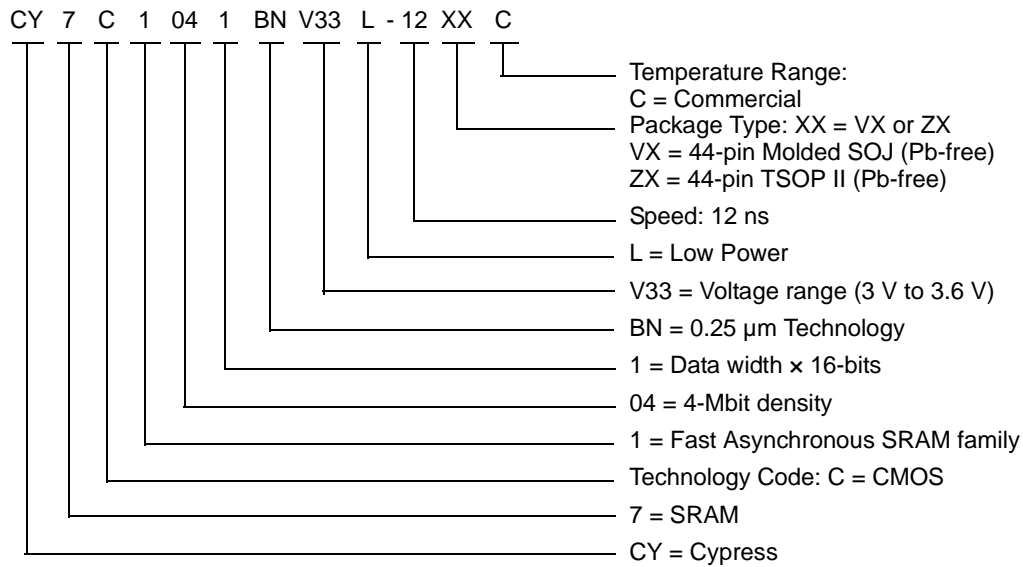

Please contact local sales representative regarding availability of these parts.

Package Diagrams

Figure 1. 44-Lead (400-Mil) Molded SOJ (51-85082)

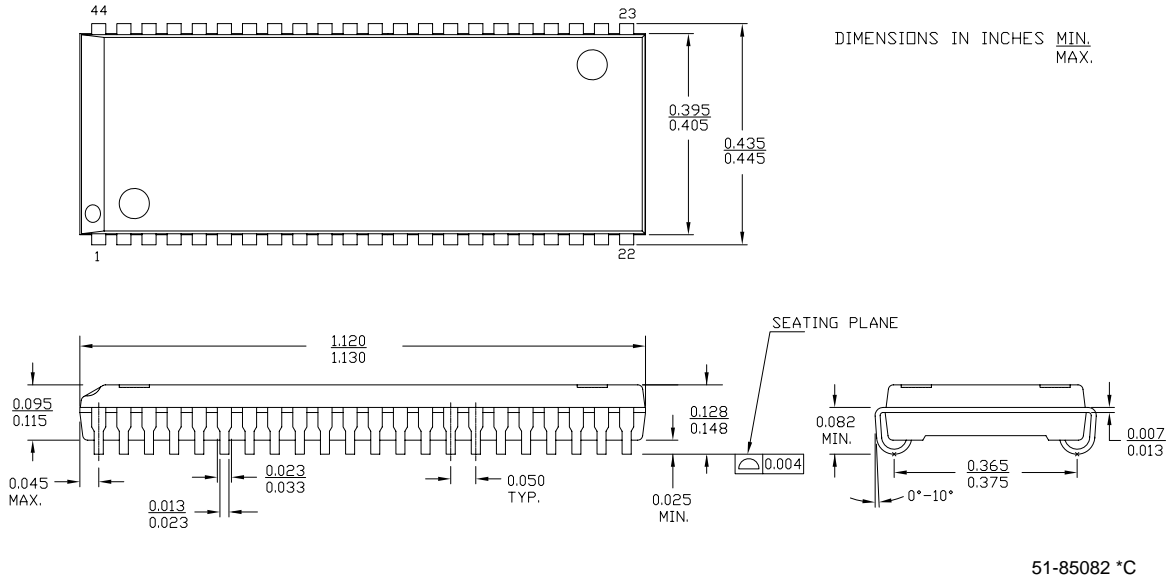
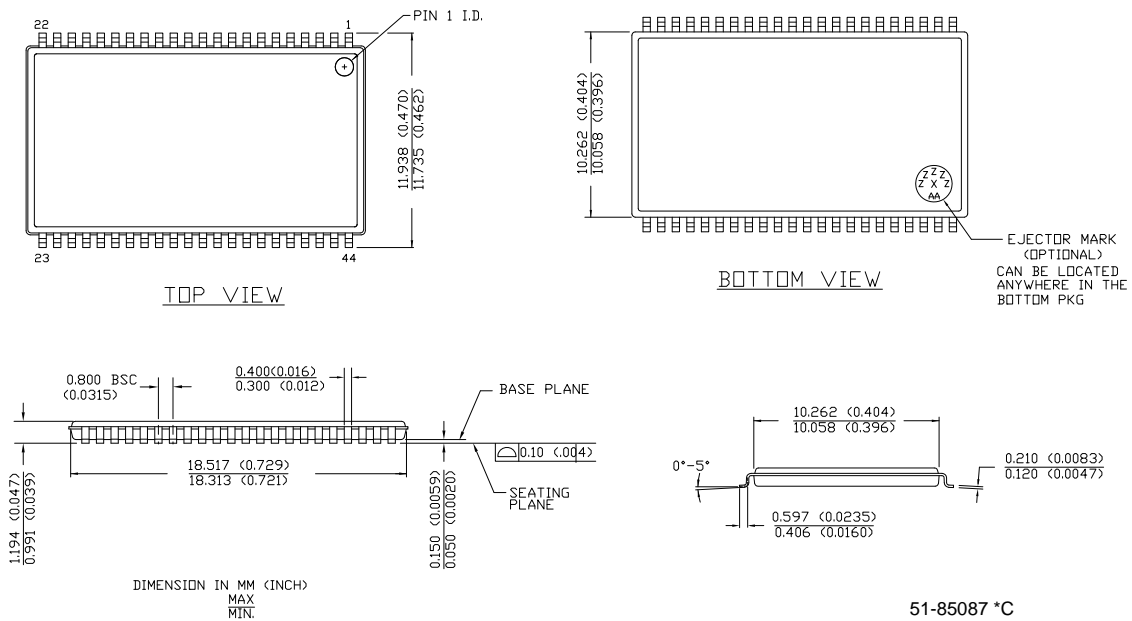

Figure 2. 44-Pin TSOP II (51-85087)



Acronyms

Acronym	Description
CMOS	Complementary metal oxide semiconductor
CE	Chip Enable
I/O	Input/output
OE	Output Enable
SRAM	Static Random Access Memory
SOJ	Small Outline J-lead
TTL	transistor-transistor logic
TSOP	thin small-outline package
WE	Write Enable

Document Conventions

Units of Measure

Symbol	Unit of Measure
°C	degree Celsius
μA	micro Amperes
mA	milli Amperes
μF	micro Farad
μs	micro seconds
ms	milli seconds
ns	nano seconds
pF	pico Farad
V	Volts
Ω	ohms
μW	micro Watts
mW	milli Watts
W	Watts
%	percent

Document History Page

Document Title: CY7C1041BNV33 256 K x 16 Static RAM Document Number: 001-06434				
Revision	ECN	Orig. of Change	Submission Date	Description of Change
**	423877	NXR	See ECN	New Data Sheet
*A	2899016	VKN	See ECN	Removed Industrial grade Removed 15ns speed Updated Ordering Information table Updated Package Diagrams
*B	3109184	AJU	12/13/2010	Added Ordering Code Definitions .
*C	3210222	PRAS	03/30/2011	Updated Selection Guide . Added Acronyms and Units of Measure . Updated in new template.
*D	3232637	PRAS	05/04/2011	Fixed unit for Input Leakage current and Output Leakage current under Electrical Characteristics table from mA to μ A.

Sales, Solutions, and Legal Information

Worldwide Sales and Design Support

Cypress maintains a worldwide network of offices, solution centers, manufacturer's representatives, and distributors. To find the office closest to you, visit us at [Cypress Locations](#).

Products

Automotive	cypress.com/go/automotive
Clocks & Buffers	cypress.com/go/clocks
Interface	cypress.com/go/interface
Lighting & Power Control	cypress.com/go/powerpsoc cypress.com/go/plc
Memory	cypress.com/go/memory
Optical & Image Sensing	cypress.com/go/image
PSoC	cypress.com/go/psoc
Touch Sensing	cypress.com/go/touch
USB Controllers	cypress.com/go/USB
Wireless/RF	cypress.com/go/wireless

PSoC Solutions

psoc.cypress.com/solutions
PSoC 1 | PSoC 3 | PSoC 5

© Cypress Semiconductor Corporation, 2006-2011. The information contained herein is subject to change without notice. Cypress Semiconductor Corporation assumes no responsibility for the use of any circuitry other than circuitry embodied in a Cypress product. Nor does it convey or imply any license under patent or other rights. Cypress products are not warranted nor intended to be used for medical, life support, life saving, critical control or safety applications, unless pursuant to an express written agreement with Cypress. Furthermore, Cypress does not authorize its products for use as critical components in life-support systems where a malfunction or failure may reasonably be expected to result in significant injury to the user. The inclusion of Cypress products in life-support systems application implies that the manufacturer assumes all risk of such use and in doing so indemnifies Cypress against all charges.



Any Source Code (software and/or firmware) is owned by Cypress Semiconductor Corporation (Cypress) and is protected by and subject to worldwide patent protection (United States and foreign), United States copyright laws and international treaty provisions. Cypress hereby grants to licensee a personal, non-exclusive, non-transferable license to copy, use, modify, create derivative works of, and compile the Cypress Source Code and derivative works for the sole purpose of creating custom software and or firmware in support of licensee product to be used only in conjunction with a Cypress integrated circuit as specified in the applicable agreement. Any reproduction, modification, translation, compilation, or representation of this Source Code except as specified above is prohibited without the express written permission of Cypress.

Disclaimer: CYPRESS MAKES NO WARRANTY OF ANY KIND, EXPRESS OR IMPLIED, WITH REGARD TO THIS MATERIAL, INCLUDING, BUT NOT LIMITED TO, THE IMPLIED WARRANTIES OF MERCHANTABILITY AND FITNESS FOR A PARTICULAR PURPOSE. Cypress reserves the right to make changes without further notice to the materials described herein. Cypress does not assume any liability arising out of the application or use of any product or circuit described herein. Cypress does not authorize its products for use as critical components in life-support systems where a malfunction or failure may reasonably be expected to result in significant injury to the user. The inclusion of Cypress' product in a life-support systems application implies that the manufacturer assumes all risk of such use and in doing so indemnifies Cypress against all charges.

Use may be limited by and subject to the applicable Cypress software license agreement.

Looking for pricing, stock, or lifecycle information?

Click below to explore more details on WIN SOURCE:

-  [View CY7C1041BNV33L-12VXC on WIN SOURCE](#)
-  [Cypress Semiconductor Corp Information](#)

Optimize Your Supply Chain with WIN SOURCE Solutions

-  Global Sourcing Solution
-  Obsolete Management
-  Cost Control Management
-  Shortage Management
-  Alternative Solution
-  Excess Inventory Management