



THE DATASHEET OF
QFS-026-01-SL-D-RA-PC4-K-TR



DO NOT SCALE FROM THIS PRINT

No OF POSITIONS
-026, -052, -078, -104
(PER ROW)

LEAD STYLE
-01: .062[1.57]
-02: .093[2.36]

PACKAGING
BLANK: TRAY (SEE NOTES 4 & 8)
-TR: TAPE & REEL (SEE NOTES 8 & 9)
-FR: FULL REEL QTY TAPE & REEL
(SEE NOTES 8 & 9)
(-TR & -FR PACKAGING AVAILABLE FOR:
-026 & -052 WITH NO OPTIONS,
-026 & -052 WITH -PC4,
-026 WITH -PC8)

PICK & PLACE OPTION
-K: POLYAMIDE FILM
(USE K-DOT-.310-.406-.005)

OPTION
-PC4: 4 POWER PINS
(SEE FIG 2, SHEET 5)
(NOT AVAILABLE WITH -104 POS)
-PC8: 8 POWER PINS
(SEE FIG 3, SHEET 5)
(NOT AVAILABLE WITH -104 POS)

-RA: RIGHT ANGLE

ROW SPECIFICATION
-D: DOUBLE (USE QFS-26-01-D-XX-RA)

PLATING SPECIFICATION
(SEE TABLE 6, SHEET 4)

-SL: 10µ" GOLD IN CONTACT AREA, MATTE TIN TAIL
-S: 30µ" GOLD IN CONTACT AREA, MATTE TIN TAIL
-L: 10µ" GOLD IN CONTACT AREA, 3µ" GOLD ON TAIL
-H: 30µ" GOLD IN CONTACT AREA, 3µ" GOLD ON TAIL

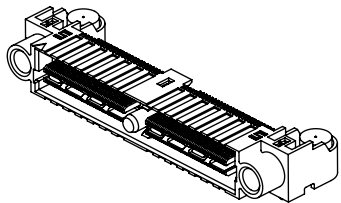
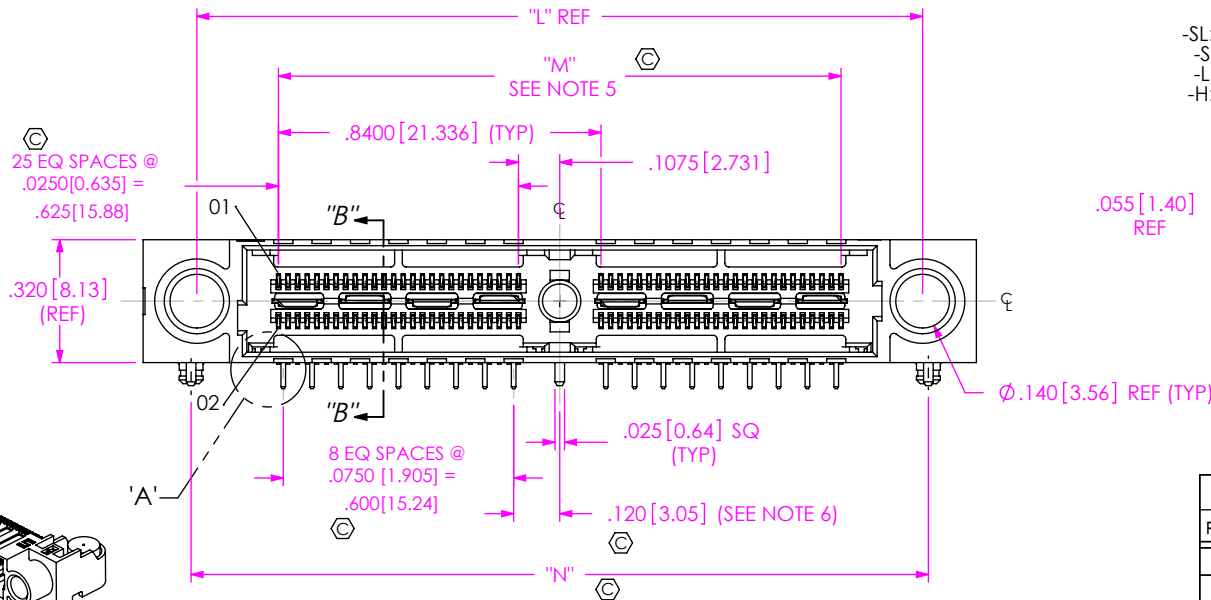
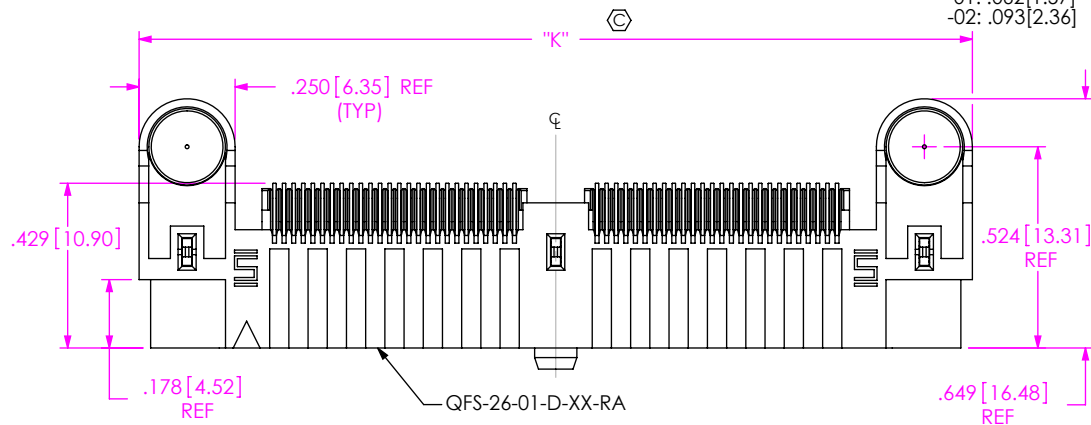

FIG 1
(QFS-052-01-XX-D-RA SHOWN)

TABLE 5				
POSITION	"K"	"L"	"M"	"N"
-026	1.330 [33.78]	1.050 [26.67]	.625 [15.88]	1.080 [27.43]
-052	2.170 [55.12]	1.890 [48.01]	1.465 [37.21]	1.920 [48.77]
-078	3.010 [76.45]	2.730 [69.34]	2.305 [58.55]	2.760 [70.10]
-104	3.850 [97.79]	3.570 [90.68]	3.145 [79.88]	3.600 [91.44]

NOTES:

1. Ⓢ REPRESENTS A CRITICAL DIMENSION.
2. MAXIMUM BURR ALLOWANCE: .0010[0.02].
3. MINIMUM PUSHOUT FORCE: SIGNAL: .5 LB [2.22 N], SHIELD/GROUND, POWER PIN AND COUNTERWEIGHT: 1 LB [4.45 N].
4. TRAYS ARE STANDARD PACKAGING.
5. PLUS .007" ALLOWED ON 4 BANK.
6. DOES NOT APPLY TO 1 BANK.
7. USE -Z- DATUM ZONE FOR ONLY MEASUREMENTS.
8. ORDERS WILL BE PACKAGED ACCORDING TO THE SAMTEC PACKAGING EFFICIENCY STANDARDS (SPES) FOUND ON WWW.SAMTEC.COM.
9. ATTACH LABEL-4X2 TO EACH REEL.

UNLESS OTHERWISE SPECIFIED, DIMENSIONS ARE IN INCHES.
TOLERANCES ARE:
DECIMALS ANGLES
.XX: ±.01 [.3] 2°
.XXX: ±.005 [.13]
.XXXX: ±.0020 [.051]

PROPRIETARY NOTE
THIS DOCUMENT CONTAINS CONFIDENTIAL AND PROPRIETARY INFORMATION AND ALL DESIGN, MANUFACTURING, REPRODUCTION, USE, PATENT RIGHTS AND SALES RIGHTS ARE EXPRESSLY RESERVED BY SAMTEC, INC. THIS DOCUMENT SHALL NOT BE DISCLOSED, IN WHOLE OR PART, TO ANY UNAUTHORIZED PERSON OR ENTITY NOR REPRODUCED, TRANSFERRED OR INCORPORATED IN ANY OTHER PROJECT IN ANY MANNER WITHOUT THE EXPRESS WRITTEN CONSENT OF SAMTEC, INC.

MATERIAL: DO NOT SCALE DRAWING SHEET SCALE: 2:1
INSULATOR: LCP, COLOR BLACK
CONTACT, POWER PIN & GROUND PLANE: PHOS BRONZE
COUNTERWEIGHT: BRASS

DESCRIPTION:
.635mm DUAL ROW RIGHT ANGLE SOCKET ASSEMBLY
DWG. NO.
QFS-XXX-XX-XX-D-RA-XXX-X-XX
BY: CLAY W 8/25/2006 SHEET 1 OF 6



520 PARK EAST BLVD, NEW ALBANY, IN 47150
PHONE: 812-944-6733 FAX: 812-948-5047
e-Mail info@SAMTEC.com code 55322

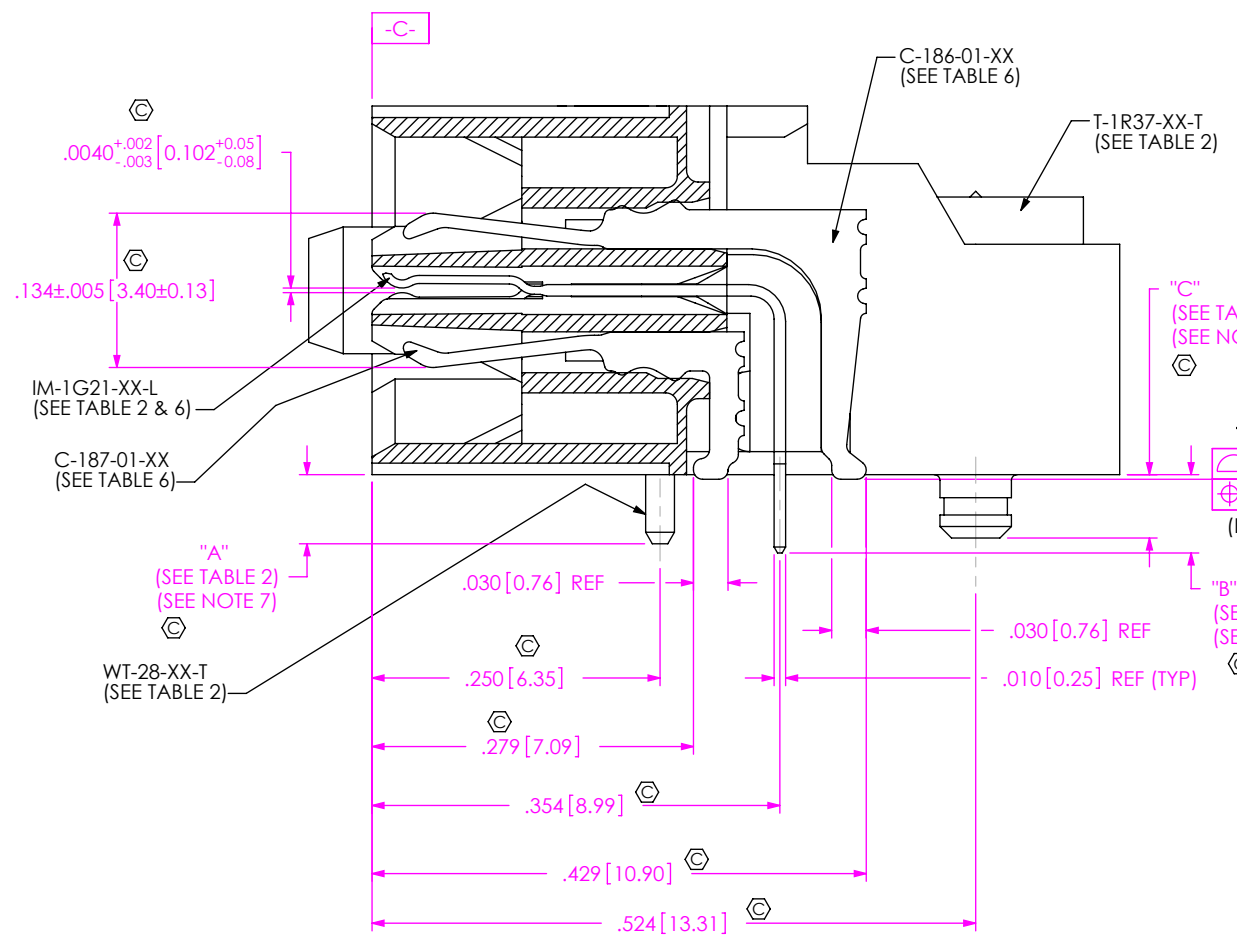

SECTION "B"- "B"
SCALE 6:1

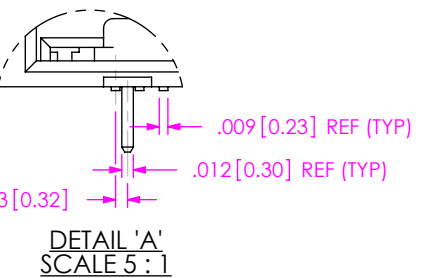

DETAIL 'A'
SCALE 5:1

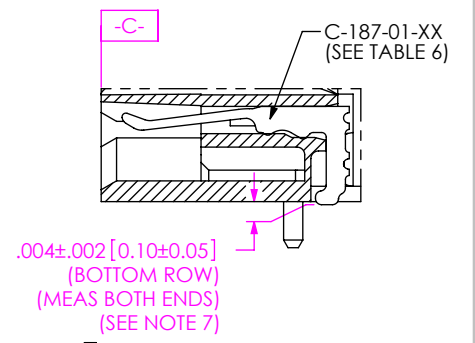

BOTTOM ROW - TAIL DETAIL
(LOCATE ASSEMBY ON DATUM -C- FOR MEASUREMENT)

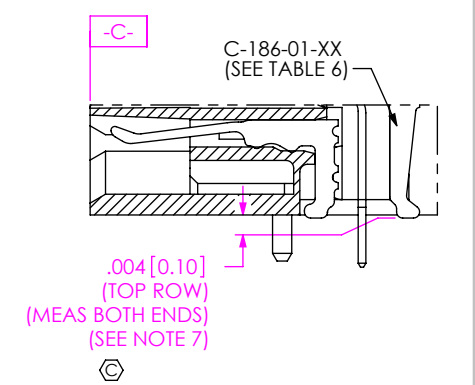

TOP ROW - TAIL DETAIL
(LOCATE ASSEMBY ON DATUM -C- FOR MEASUREMENT)

SEE TABLE 1
 TOP ROW & BOTTOM ROW
 (LOCATE ASSY ON DATUM -C- FOR MEASUREMENT)

TABLE 1

No OF POSITIONS	COPLANARITY	STRAIGHTNESS ROW 1	STRAIGHTNESS ROW 2
-026 THRU -052	.004[.10]	.004[.10]	.004[.10]
-078 THRU -104	.006[.15]	.006[.15]	.006[.15]

TABLE 2

LEAD STYLE	"A"	"B"	"C"	WT-28-XX-T	IM-1G21-XX-L	T-1R37-XX-T
-01	.060[1.52]	.068[1.73]	.055[1.40]	WT-28-01-T	IM-1G21-01-L	T-1R37-01-T
-02	.091[2.31]	.099[2.51]	.086[2.18]	WT-28-02-T	IM-1G21-02-L	T-1R37-02-T

PROPRIETARY NOTE
 THIS DOCUMENT CONTAINS CONFIDENTIAL AND PROPRIETARY INFORMATION AND ALL DESIGN, MANUFACTURING, REPRODUCTION, USE, PATENT RIGHTS AND SALES RIGHTS ARE EXPRESSLY RESERVED BY SAMTEC, INC. THIS DOCUMENT SHALL NOT BE DISCLOSED, IN WHOLE OR IN PART, TO ANY UNAUTHORIZED PERSON OR ENTITY NOR REPRODUCED, TRANSFERRED OR INCORPORATED IN ANY OTHER PROJECT IN ANY MANNER WITHOUT THE EXPRESS WRITTEN CONSENT OF SAMTEC, INC.



520 PARK EAST BLVD, NEW ALBANY, IN 47150
 PHONE: 812-944-6733 FAX: 812-948-5047
 e-Mail info@SAMTEC.com code 5332

DO NOT SCALE DRAWING

SHEET SCALE: 6:1

DESCRIPTION:
.635mm DUAL ROW RIGHT ANGLE SOCKET ASSEMBLY

DWG. NO.
QFS-XXX-XX-XX-D-RA-XXX-X-XX

BY: CLAY W 8/25/2006 SHEET 2 OF 6

INSPECTION VIEW 1
(FILL BOTTOM ROW)

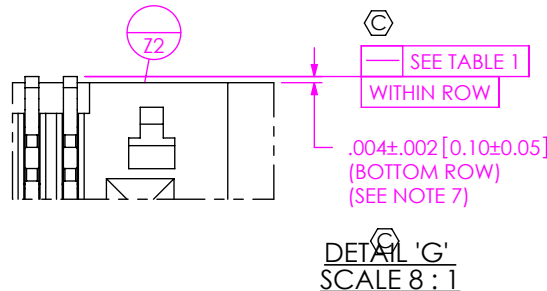
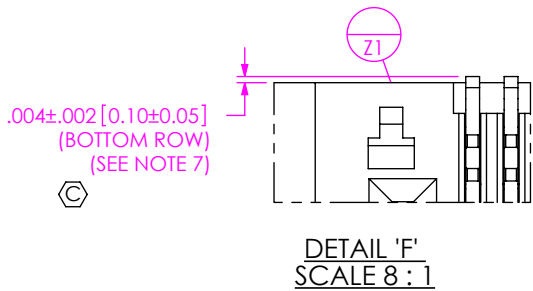
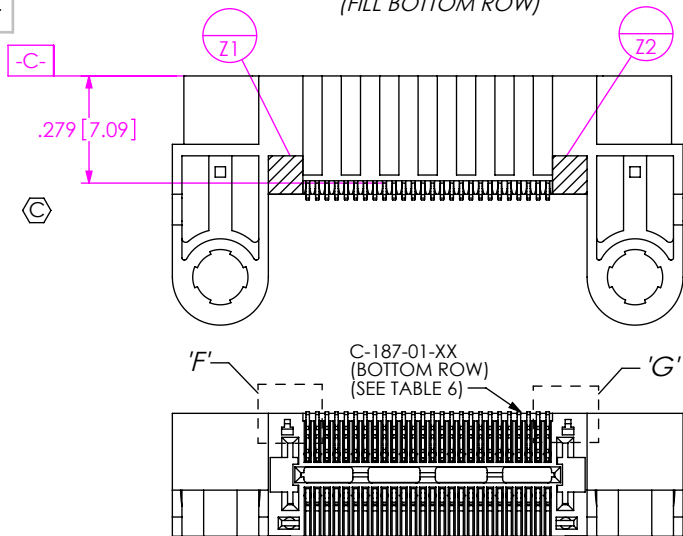

INSPECTION VIEW 2
(FILL IM-1G21)

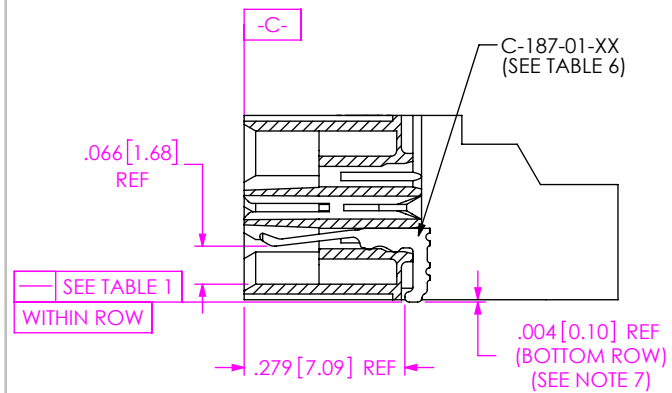
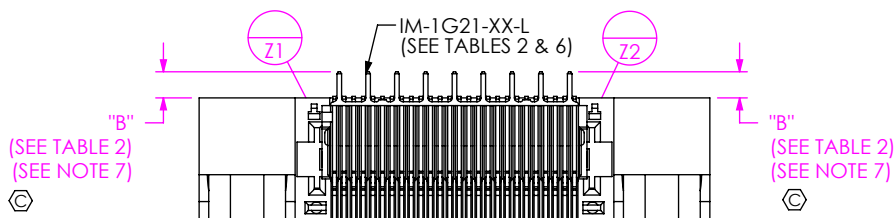
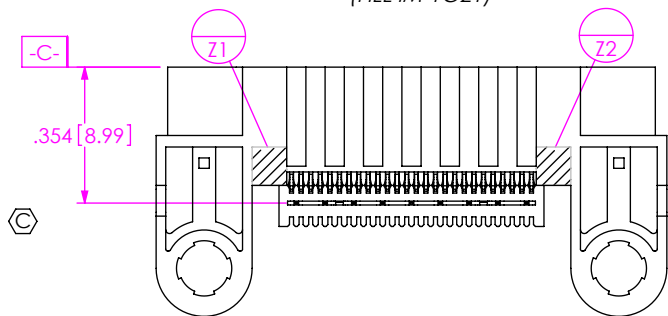

IN-PROCESS 1
(FILL BOTTOM ROW)
(SEE INSPECTION VIEW 1 FOR ORIENTATION AND CPC'S)

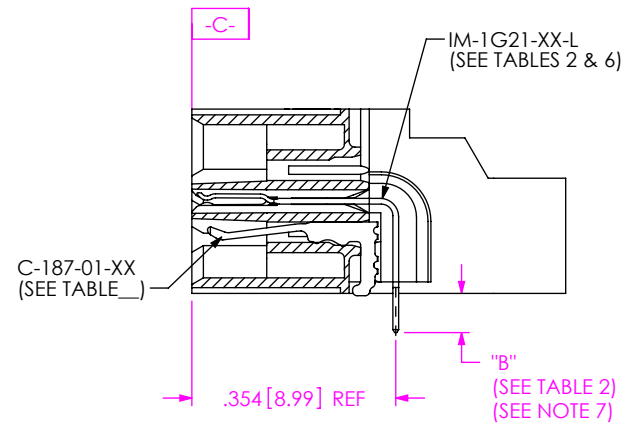

IN-PROCESS 2
(FILL IM-1G21)
(SEE INSPECTION VIEW 2 FOR ORIENTATION AND CPC'S)

PROPRIETARY NOTE
THIS DOCUMENT CONTAINS CONFIDENTIAL AND PROPRIETARY INFORMATION AND ALL DESIGN, MANUFACTURING, REPRODUCTION, USE, PATENT RIGHTS AND SALES RIGHTS ARE EXPRESSLY RESERVED BY SAMTEC, INC. THIS DOCUMENT SHALL NOT BE DISCLOSED, IN WHOLE OR PART, TO ANY UNAUTHORIZED PERSON OR ENTITY NOR REPRODUCED, TRANSFERRED OR INCORPORATED IN ANY OTHER PROJECT IN ANY MANNER WITHOUT THE EXPRESS WRITTEN CONSENT OF SAMTEC, INC.

DO NOT SCALE DRAWING
SHEET SCALE: 2:1



520 PARK EAST BLVD. NEW ALBANY, IN 47150
PHONE: 812-944-6733 FAX: 812-948-5047
e-Mail info@SAMTEC.com code 55322

DESCRIPTION:
.635mm DUAL ROW RIGHT ANGLE SOCKET ASSEMBLY

DWG. NO.
QFS-XXX-XX-XX-D-RA-XXX-X-XX

BY: CLAY W 8/25/2006 SHEET 3 OF 6

INSPECTION VIEW 3
(FILL TOP ROW)

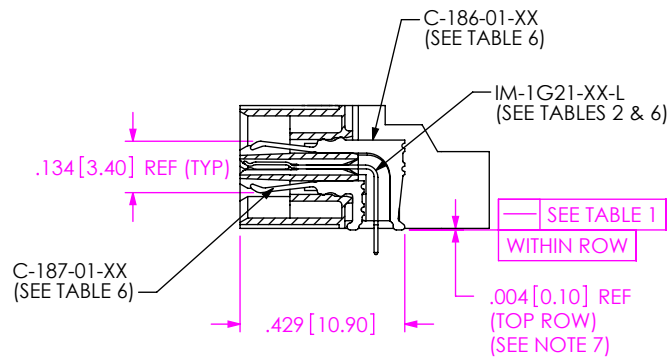
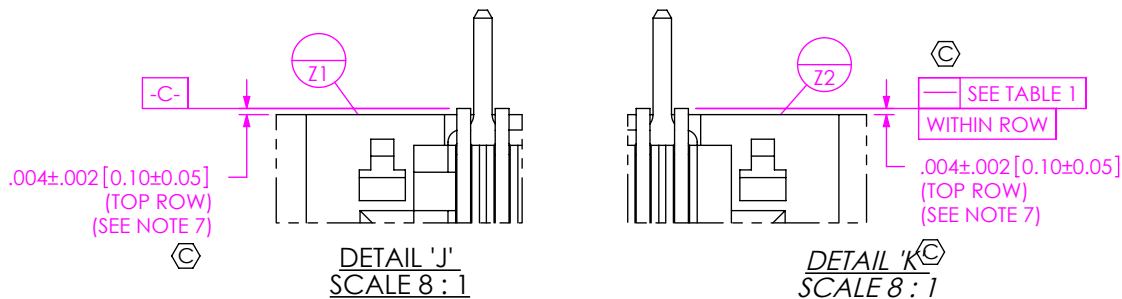
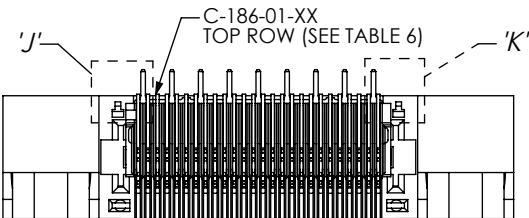
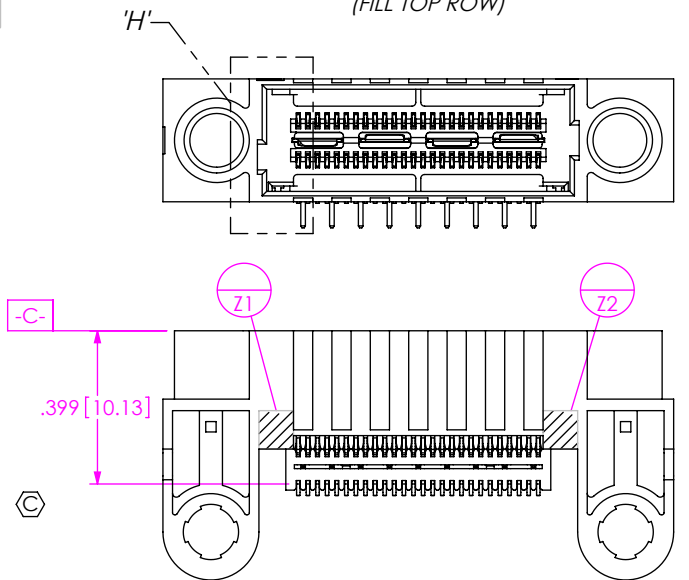

IN-PROCESS 3
(FILL TOP ROW)
(SEE INSPECTION VIEW 3 FOR ORIENTATION AND CPC'S)

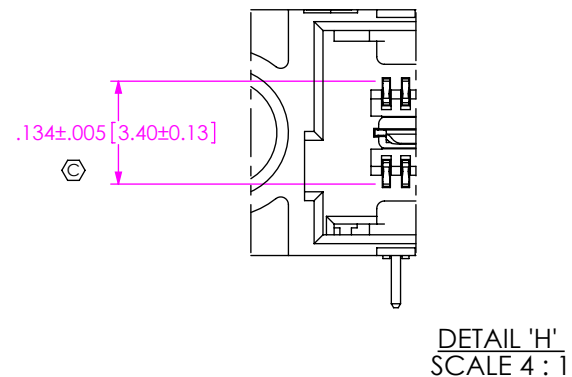

TABLE 6: PLATING SPECIFICATIONS

	CONTACT	CONTACT	GROUND PLANE	PCX CONTACTS
-SL	C-186-01-SL: 10µ" GOLD CONTACT, MATTE TIN TAIL	C-187-01-SL: 10µ" GOLD CONTACT, MATTE TIN TAIL	IM-1G21-XX-L: 10µ" GOLD CONTACT, MATTE TIN TAIL	C-79-XX-L: 10µ" GOLD CONTACT, MATTE TIN TAIL
-S	C-186-01-S: 30µ" GOLD CONTACT, MATTE TIN TAIL	C-187-01-S: 30µ" GOLD CONTACT, MATTE TIN TAIL	IM-1G21-XX-L: 10µ" GOLD CONTACT, MATTE TIN TAIL	C-79-XX-S: 30µ" GOLD CONTACT, MATTE TIN TAIL
-L	C-186-01-L: 10µ" GOLD CONTACT, 3µ" GOLD TAIL	C-187-01-L: 10µ" GOLD CONTACT, 3µ" GOLD TAIL	IM-1G21-XX-L: 10µ" GOLD CONTACT, MATTE TIN TAIL	C-79-XX-L: 10µ" GOLD CONTACT, MATTE TIN TAIL
-H	C-186-01-H: 30µ" GOLD CONTACT, 3µ" GOLD TAIL	C-187-01-H: 30µ" GOLD CONTACT, 3µ" GOLD TAIL	IM-1G21-XX-L: 10µ" GOLD CONTACT, MATTE TIN TAIL	C-79-XX-H: 50µ" GOLD CONTACT, 3µ" LIGHT GOLD TAIL

PROPRIETARY NOTE
THIS DOCUMENT CONTAINS CONFIDENTIAL AND PROPRIETARY INFORMATION AND ALL DESIGN, MANUFACTURING, REPRODUCTION, USE, PATENT RIGHTS AND SALES RIGHTS ARE EXPRESSLY RESERVED BY SAMTEC, INC. THIS DOCUMENT SHALL NOT BE DISCLOSED, IN WHOLE OR PART, TO ANY UNAUTHORIZED PERSON OR ENTITY NOR REPRODUCED, TRANSFERRED OR INCORPORATED IN ANY OTHER PROJECT IN ANY MANNER WITHOUT THE EXPRESS WRITTEN CONSENT OF SAMTEC, INC.

DO NOT SCALE DRAWING

SHEET SCALE: 1:1



520 PARK EAST BLVD, NEW ALBANY, IN 47150
PHONE: 812-944-6733 FAX: 812-948-5047
e-Mail info@SAMTEC.com code 55322

DESCRIPTION:
.635mm DUAL ROW RIGHT ANGLE SOCKET ASSEMBLY

DWG. NO.
QFS-XXX-XX-XX-D-RA-XXX-X-XX

BY: CLAY W 8/25/2006 SHEET 4 OF 6

FIG 2
(QFS-052-01-XX-D-RA-PC4 SHOWN)
(SAME AS FIG 1, DIFFERENT AS SHOWN)

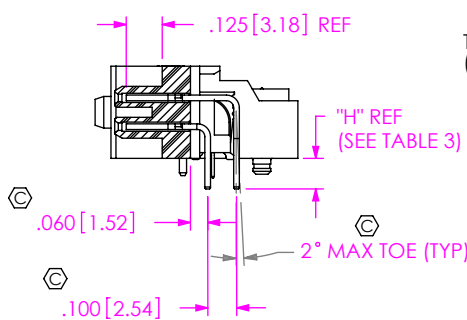
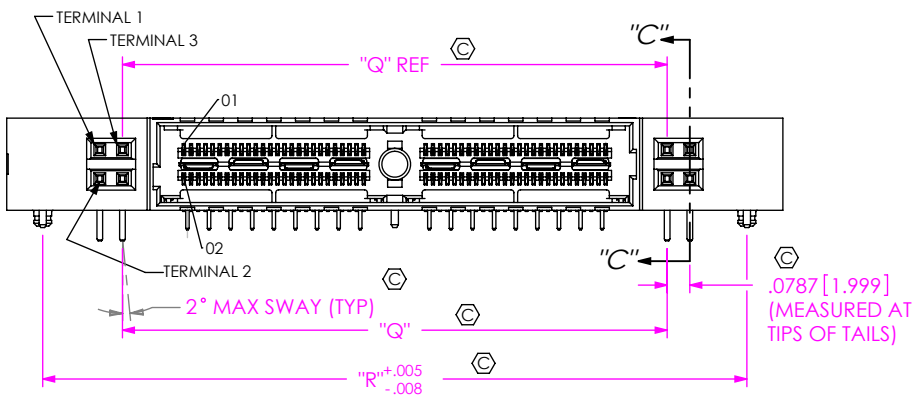
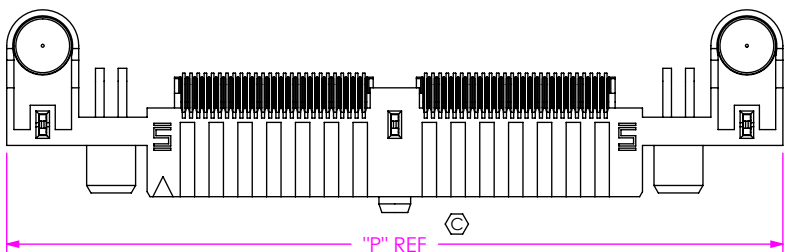

SECTION "C"- "C"
SCALE 1.5:1

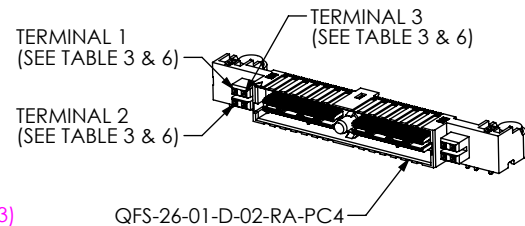
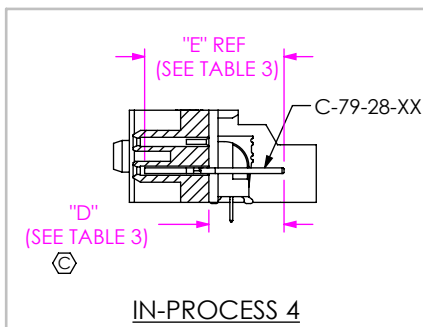

TABLE 3

LEAD STYLE	TERMINAL 1	TERMINAL 2	"D"	"E"	"F"	"G"	"H"
-01	C-79-28-XX	C-79-29-XX	.261 [6.63]	.484 [12.29]	.461 [11.71]	.684 [17.37]	.106 [2.69]
-02	C-79-20-XX	C-79-20A-XX	.287 [7.29]	.510 [12.95]	.487 [12.37]	.710 [18.03]	.132 [3.35]



IN-PROCESS 4

FIG 3
(QFS-052-01-XX-D-RA-PC8 SHOWN)
(SAME AS FIG 2, DIFFERENT AS SHOWN)

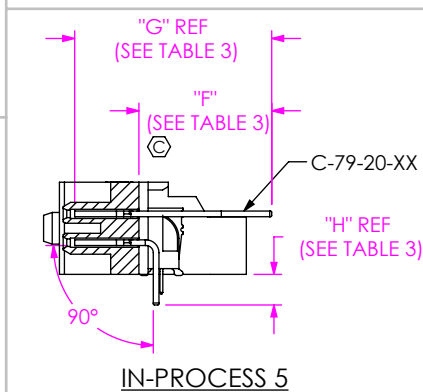
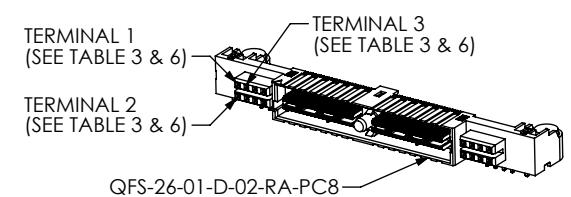
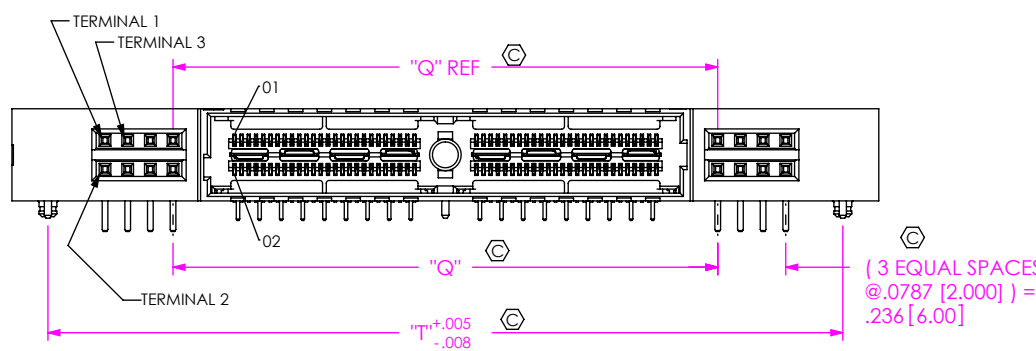
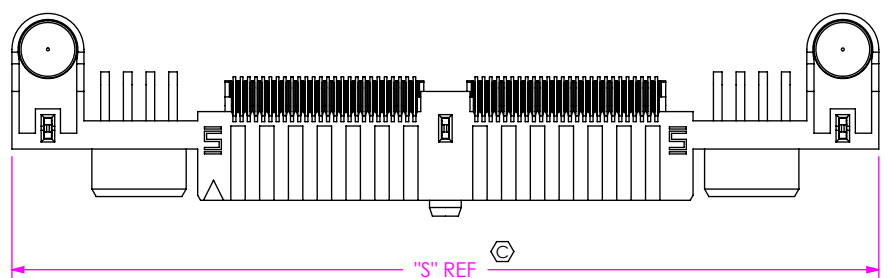

IN-PROCESS 5

TABLE 7

POSITION	"P"	"Q"	"R"	"S"	"T"
-026	1.855 [47.12]	1.051 [26.70]	1.605 [40.77]	2.170 [55.12]	1.920 [48.77]
-052	2.695 [68.45]	1.891 [48.03]	2.445 [62.10]	3.010 [76.45]	2.760 [70.10]
-078	3.535 [89.79]	2.731 [69.37]	3.285 [83.44]	3.850 [97.79]	3.600 [91.44]
-104	4.375 [111.13]	3.571 [90.70]	4.125 [104.78]	4.690 [119.13]	4.440 [112.78]

PROPRIETARY NOTE
THIS DOCUMENT CONTAINS CONFIDENTIAL AND PROPRIETARY INFORMATION AND ALL DESIGN, MANUFACTURING, REPRODUCTION, USE, PATENT RIGHTS AND SALES RIGHTS ARE EXPRESSLY RESERVED BY SAMTEC, INC. THIS DOCUMENT SHALL NOT BE DISCLOSED, IN WHOLE OR PART, TO ANY UNAUTHORIZED PERSON OR ENTITY NOR REPRODUCED, TRANSFERRED OR INCORPORATED IN ANY OTHER PROJECT IN ANY MANNER WITHOUT THE EXPRESS WRITTEN CONSENT OF SAMTEC, INC.

DO NOT SCALE DRAWING
SHEET SCALE: 1.5:1



520 PARK EAST BLVD, NEW ALBANY, IN 47150
PHONE: 812-944-6733 FAX: 812-948-5047
e-Mail info@SAMTEC.com code 55322

DESCRIPTION:
.635mm DUAL ROW RIGHT ANGLE SOCKET ASSEMBLY
DWG. NO.
QFS-XXX-XX-XX-D-RA-XXX-X-XX
BY: CLAY W 8/25/2006 SHEET 5 OF 6

TABLE 4			
	STANDARD & -MG	-PC4	-PC8
POS.	"U"		
-026	0.511 [12.98]	0.774 [19.66]	0.931 [23.65]
-052	0.931 [23.65]	1.194 [30.33]	1.351 [34.32]
-078	1.351 [34.32]	1.614 [41.00]	1.771 [44.98]
-104	1.771 [44.98]	2.033 [51.65]	2.091 [53.11]

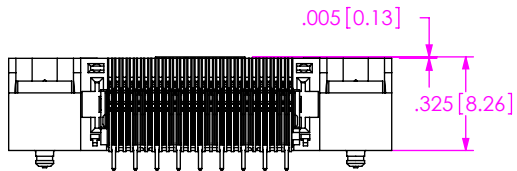
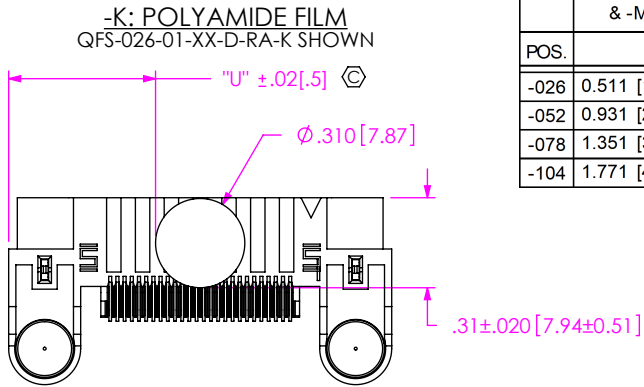
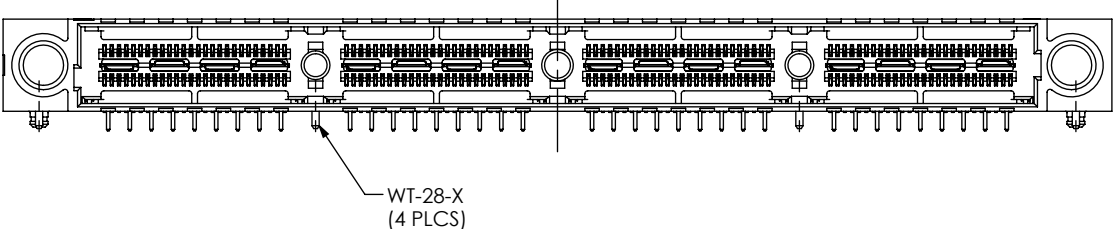
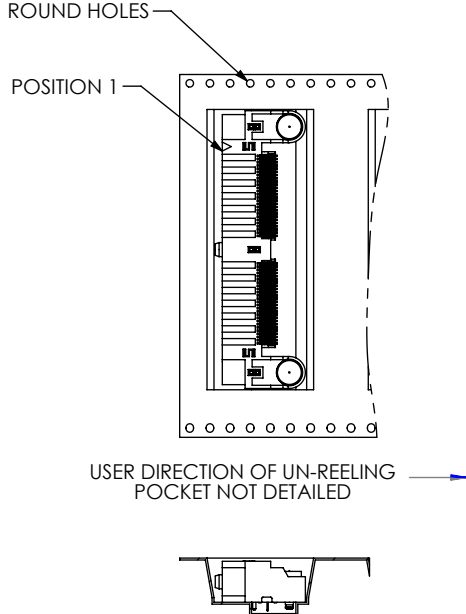

FIG 4
(QFS-104-01-XX-D-RA SHOWN)
(SAME AS FIG 1, DIFFERENT AS SHOWN)



PACKAGING VIEW
-TR: TAPE & REEL OPTION
(QFS-052-01-XX-D-RA-TR SHOWN)



PROPRIETARY NOTE
THIS DOCUMENT CONTAINS CONFIDENTIAL AND PROPRIETARY INFORMATION AND ALL DESIGN, MANUFACTURING, REPRODUCTION, USE, PATENT RIGHTS AND SALES RIGHTS ARE EXPRESSLY RESERVED BY SAMTEC, INC. THIS DOCUMENT SHALL NOT BE DISCLOSED, IN WHOLE OR PART, TO ANY UNAUTHORIZED PERSON OR ENTITY NOR REPRODUCED, TRANSFERRED OR INCORPORATED IN ANY OTHER PROJECT IN ANY MANNER WITHOUT THE EXPRESS WRITTEN CONSENT OF SAMTEC, INC.

DO NOT SCALE DRAWING

SHEET SCALE: 6:1

samtec

520 PARK EAST BLVD, NEW ALBANY, IN 47150
PHONE: 812-944-6733 FAX: 812-948-5047
e-Mail info@SAMTEC.com code 55322



DESCRIPTION:
.635mm DUAL ROW RIGHT ANGLE SOCKET ASSEMBLY

DWG. NO.
QFS-XXX-XX-XX-D-RA-XXX-X-XX

BY: CLAY W 8/25/2006 SHEET 6 OF 6

Looking for pricing, stock, or lifecycle information?

Click below to explore more details on WIN SOURCE:

-  [View QFS-026-01-SL-D-RA-PC4-K-TR on WIN SOURCE](#)
-  [Samtec Inc. Information](#)

Optimize Your Supply Chain with WIN SOURCE Solutions

-  Global Sourcing Solution
-  Obsolete Management
-  Cost Control Management
-  Shortage Management
-  Alternative Solution
-  Excess Inventory Management