



**THE DATASHEET OF  
IDT72V73273BBG**





# 3.3 VOLT TIME SLOT INTERCHANGE DIGITAL SWITCH WITH RATE MATCHING 32,768 x 32,768 CHANNELS

IDT72V73273

## FEATURES:

- Up to 64 serial input and output streams
- Maximum 32,768 x 32,768 channel non-blocking switching
- Accepts data streams at 2.048Mb/s, 4.096Mb/s, 8.192Mb/s, 16.384Mb/s or 32.768Mb/s
- Rate matching capability: rate selectable on both RX and TX in eight groups of 8 streams
- Optional Output Enable Indication Pins for external driver High-Z control
- Per-channel Variable Delay Mode for low-latency applications
- Per-channel Constant Delay Mode for frame integrity applications
- Enhanced Block programming capabilities
- TX/RX Internal Bypass
- Automatic identification of ST-BUS® and GCI serial streams
- Per-stream frame delay offset programming
- Per-channel High-Impedance output control
- Per-channel processor mode to allow microprocessor writes to TX streams
- Bit Error Rate Testing (BERT) for testing
- Direct microprocessor access to all internal memories

- Selectable Synchronous and Asynchronous microprocessor bus timing modes
- IEEE-1149.1 (JTAG) Test Port
- 208-pin (17mm x 17mm) Plastic Ball Grid Array (PBGA)
- Operating Temperature Range -40°C to +85°C

## DESCRIPTION:

The IDT72V73273 has a non-blocking switch capacity of 32,768 x 32,768 channels at 32.768Mb/s. With 64 inputs and 64 outputs, programmable per stream control, and a variety of operating modes the IDT72V73273 is designed for the TDM time slot interchange function in either voice or data applications.

Some of the main features of the IDT72V73273 are LOW power 3.3 Volt operation, automatic ST-BUS®/GCI sensing, memory block programming, simple microprocessor interface, JTAG Test Access Port (TAP) and per stream programmable input offset delay, variable or constant throughput modes, output enable and processor mode, BER testing, bypass mode, and advanced block programming.

## FUNCTIONAL BLOCK DIAGRAM

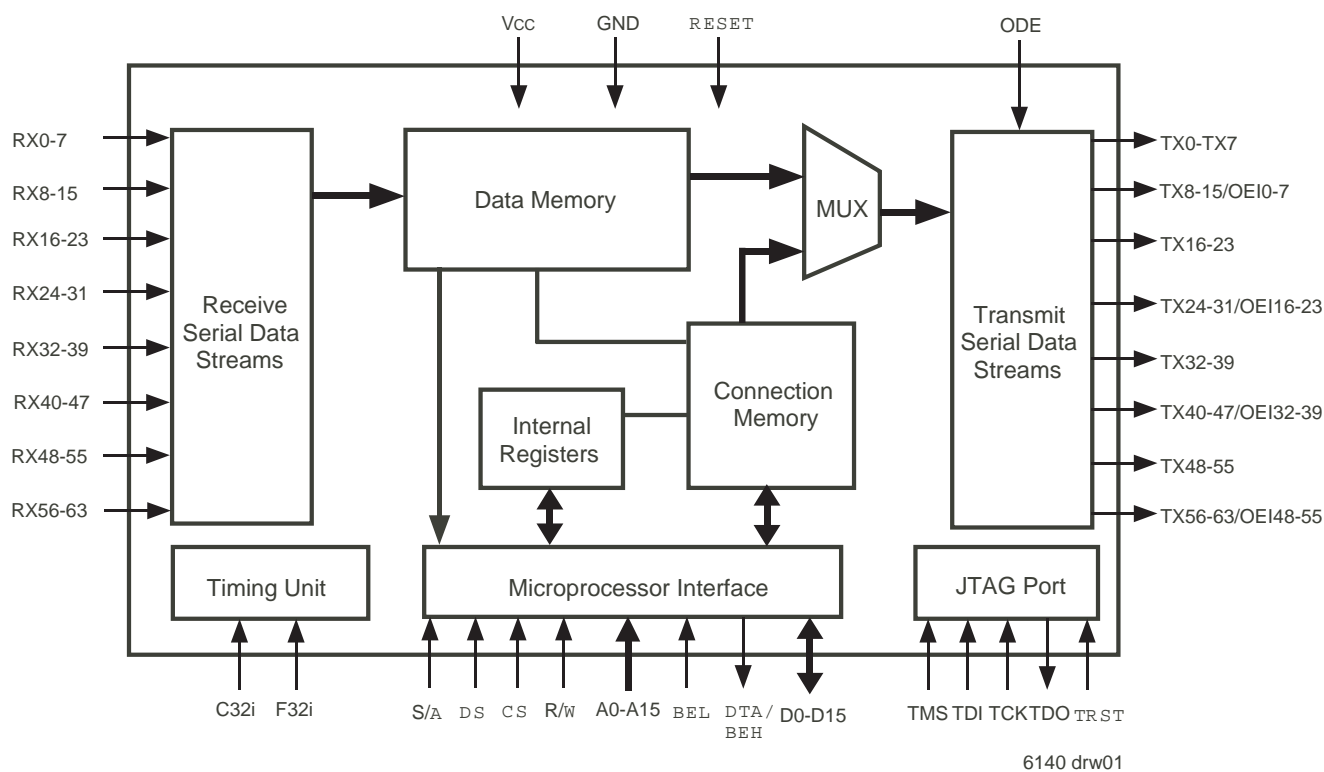

# PIN CONFIGURATIONS

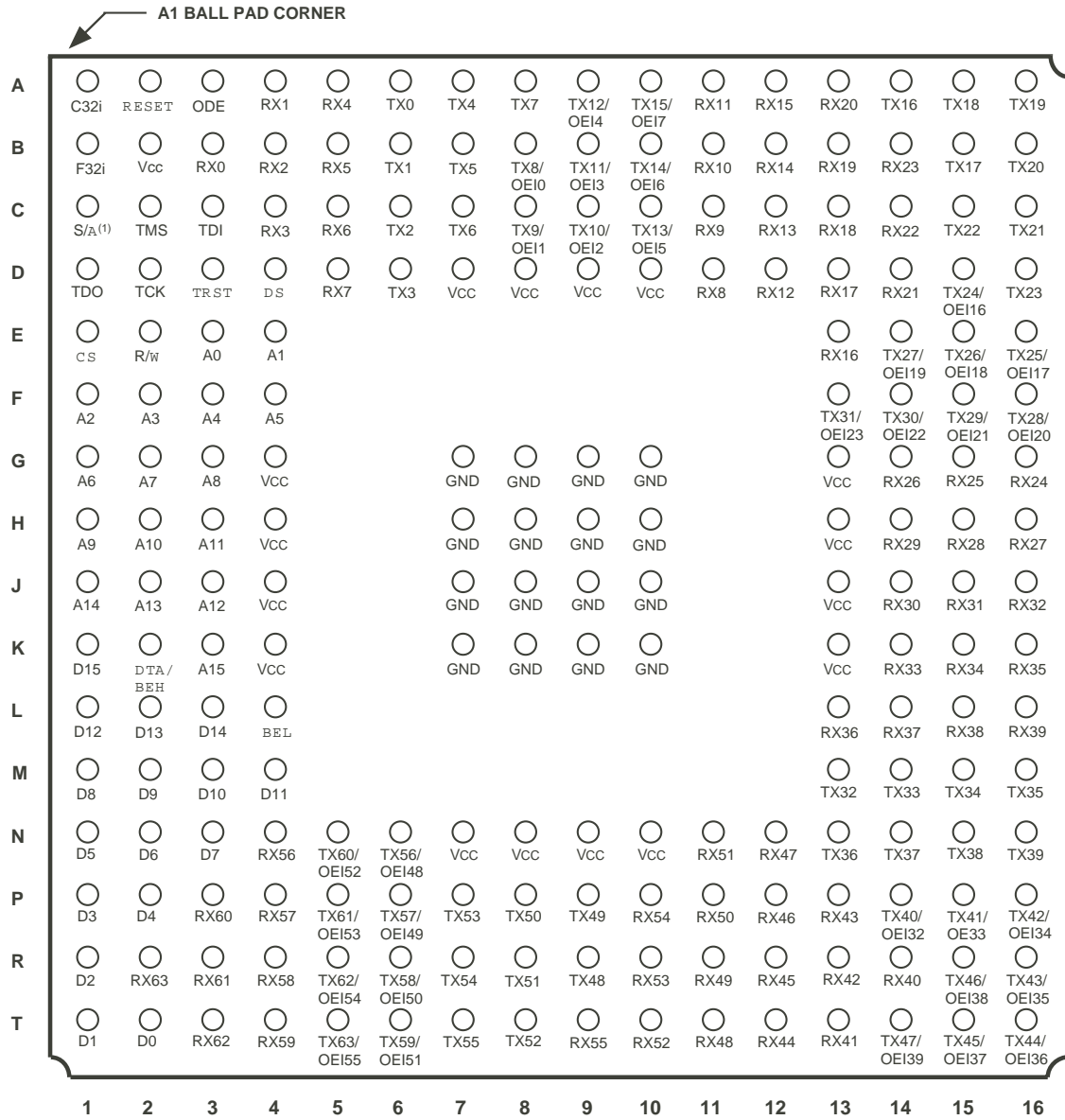

6140 drw03

**NOTES:**

1. S/A should be tied directly to Vcc or GND for proper operation.

PBGA: 1mm pitch, 17mm x 17mm (BB208-1 order code: BB)  
 TOP VIEW

**PIN DESCRIPTION**

SYMBOL	NAME	I/O	PQFP PIN NO.	PBGA PIN NO.	DESCRIPTION
A0-A15	Address 0-15	I	*See PQFP Table Below	*See PBGA Table Below	These address lines access all internal memories.
$\overline{\text{BEL}}$	Byte Enable LOW	I	31	L4	In synchronous mode, this input will enable the lower byte (D0-7) on to the data bus.
C32i	Clock	I	2	A1	Serial clock for shifting data in/out on the serial data streams. This input accepts a 32.768MHz clock.
$\overline{\text{CS}}$	Chip Select	I	12	E1	Active LOW input used by a microprocessor to activate the microprocessor port of the device.
D0-15	Data Bus 0-15	I/O	*See PQFP Table Below	*See PBGA Table Below	These pins are the data bus of the microprocessor port.
$\overline{\text{DS}}$	Data Strobe	I	11	D4	This active LOW input works in conjunction with $\overline{\text{CS}}$ to enable the read and write operations. This active LOW input sets the data bus lines (D0-D15).
$\overline{\text{DTA/BEH}}$	Data Transfer Acknowledgment Active LOW Output /Byte Enable HIGH	I/O	32	K2	In asynchronous mode this pin indicates that a data bus transfer is complete. When the bus cycle ends, this pin drives HIGH and then High-Z allowing for faster bus cycles with a weaker pull-up resistor. A pull-up resistor is required to hold a HIGH level when the pin is High-Z. When the device is in synchronous bus mode, this pin acts as an input and will enable the upper byte (D8-15) on to the data bus.
F32i	Frame Pulse	I	3	B1	This input accepts and automatically identifies frame synchronization signals formatted according to ST-BUS <sup>®</sup> and GCI specifications.
GND			*See PQFP Table Below	*See PBGA Table Below	Ground.
ODE	Output Drive Enable	I	207	A3	This is the output enable control for the TX serial outputs. When ODE input is LOW and the OSB bit of the CR register is LOW, all TX outputs are in a High-Impedance state. If this input is HIGH, the TX output drivers are enabled. However, each channel may still be put into a High-Impedance state by using the per channel control bits in the Connection Memory HIGH.
RX0-63	RX Input 0 to 63	I	*See PQFP Table Below	*See PBGA Table Below	Serial data Input Stream. These streams may have data rates of 2.048Mb/s, 4.096Mb/s, 8.192Mb/s, 16.384Mb/s, or 32.768Mb/s depending upon the selection in Receive Data Rate Selection Register (RDRSR).
$\overline{\text{RESET}}$	Device Reset:	I	208	A2	This input (active LOW) puts the device in its reset state that clears the device internal counters, registers and brings TX0-63 and microport data outputs to a High-Impedance state. The $\overline{\text{RESET}}$ pin must be held LOW for a minimum of 20ns to reset the device.
$\overline{\text{R/W}}$	Read/Write	I	13	E2	This input controls the direction of the data bus lines (D0-D15) during a microprocessor access.
$\text{S}/\overline{\text{A}}$	Synchronous/ Asynchronous Bus Mode	I	5	C1	This input will select between asynchronous microprocessor bus timing and synchronous microprocessor bus timing. In synchronous mode, $\overline{\text{DTA/BEH}}$ acts as the $\overline{\text{BEH}}$ input and is used in conjunction with $\overline{\text{BEL}}$ to output data on the data bus. In asynchronous bus mode, $\overline{\text{BEL}}$ is tied LOW and $\overline{\text{DTA/BEH}}$ acts as the DTA, data bus acknowledgment output.
TCK	Test Clock	I	9	D2	Provides the clock to the JTAG test logic.
TDI	Test Serial Data In	I	7	C3	JTAG serial test instructions and data are shifted in on this pin. This pin is pulled HIGH by an internal pull-up when not driven.
TDO	Test Serial Data Out	O	8	D1	JTAG serial data is output on this pin on the falling edge of TCK. This pin is held in High-Impedance state when JTAG scan is not enabled.
TMS	Test Mode Select	I	6	C2	JTAG signal that controls the state transitions of the TAP controller. This pin is pulled HIGH by an internal pull-up when not driven.
$\overline{\text{TRST}}$	Test Reset	I	10	D3	Asynchronously initializes the JTAG TAP controller by putting it in the Test-Logic-Reset state. This pin is pulled by an internal pull-up when not driven. This pin should be pulsed LOW on power-up, or held LOW, to ensure that the device

**PIN DESCRIPTION (CONTINUED)**

SYMBOL	NAME	I/O	PQFP PIN NO.	PBGA PIN NO.	DESCRIPTION
TX0-7 TX16-23 TX32-39 TX48-55	TX Output	O	*See PQFP Table Below	*See PBGA Table Below	Serial Data Output Stream. These streams may have data rates of 2.048Mb/s, 4.096Mb/s, 8.192Mb/s, 16.384Mb/s, or 32.768Mb/s depending upon the selection in Transmit Data Rate Selection Register (TDRSR).
TX8-15/OEI0-7 TX24-31/OEI16-23 TX40-47/OEI32-39 TX56-63/OEI48-55	TX Output/Output Enable Indication	O	*See PQFP Table Below	*See PBGA Table Below	When output streams are selected via TDRSR, these pins are the TX output streams. When output enable indication function is selected, these pins reflect the active or High-Impedance status for the corresponding TX output stream.
Vcc			*See PQFP Table Below	*See PBGA Table Below	+3.3 Volt Power Supply. is in the normal functional mode.

**PBGA PIN NUMBER TABLE**

SYMBOL	NAME	I/O	DESCRIPTION
A0-A15	Address A0-A15	I	E3, E4, F1, F2, F3, F4, G1, G2, G3, H1, H2, H3, J3, J2, J1, K3.
D0-D15	Data Bus 0-15	I/O	T2, T1, R1, P1, P2, N1, N2, N3, M1, M2, M3, M4, L1, L2, L3, K1.
GND	Ground		G7, G8, G9, G10, H7, H8, H9, H10, J7, J8, J9, J10, K7, K8, K9, K10.
RX0-63	RX Input 0 to 63	I	B3, A4, B4, C4, A5, B5, C5, D5, D11, C11, B11, A11, D12, C12, B12, A12, E13, D13, C13, B13, A13, D14, C14, B14, G16, G15, G14, H16, H15, H14, J14, J15, J16, K14, K15, K16, L13, L14, L15, L16, R14, T13, R13, P13, T12, R12, P12, N12, T11, R11, P11, N11, T10, R10, P10, T9, N4, P4, R4, T4, P3, R3, T3, R2.
TX0-7 TX16-23 TX32-39 TX48-55	TX Output	O	A6, B6, C6, D6, A7, B7, C7, A8. A14, B15, A15, A16, B16, C16, C15, D16. M13, M14, M15, M16, N13, N14, N15, N16. R9, P9, P8, R8, T8, P7, R7, T7.
TX8-15/OEI0-7 TX24-31/OEI16-23 TX40-47/OEI32-39 TX56-63/OEI48-55	TX Output/Output	O	B8, C8, C9, B9, A9, C10, B10, A10. D15, E16, E15, E14, F16, F15, F14, F13. P14, P15, P16, R16, T16, T15, R15, T14. N6, P6, R6, T6, N5, P5, R5, T5.
Vcc			B2, D7, D8, D9, D10, G4, G13, H4, H13, J4, J13, K4, K13, N7, N8, N9, N10.

## DESCRIPTION (CONTINUED)

The IDT72V73273 is capable of switching up to 32,768 x 32,768 channels without blocking. Designed to switch 64 Kbit/s PCM or N x 64 Kbit/s data, the device maintains frame integrity in data applications and minimizes throughput delay for voice applications on a per-channel basis.

The 64 serial input streams (RX) of the IDT72V73273 can be run at 2.048Mb/s, 4.096Mb/s, 8.192Mb/s, 16.384Mb/s or 32.768Mb/s allowing 32, 64, 128, 256 or 512 channels per 125µs frame. The data rates on the output streams can independently be programmed to run at any of these data rates.

With two main operating modes, Processor Mode and Connection Mode, the IDT72V73273 can easily switch data from incoming serial streams (Data Memory) or from the controlling microprocessor via Connection Memory.

As control and status information is critical in data transmission, the Processor Mode is especially useful when there are multiple devices sharing the input and output streams.

With data coming from multiple sources and through different paths, data entering the device is often delayed. To handle this problem, the IDT72V73273 has a Frame Offset feature to allow individual streams to be offset from the frame pulse in half clock-cycle intervals up to +7.5 clock cycles.

The IDT72V73273 also provides a JTAG test access port, memory block programming, Group Block Programming, RX/TX internal bypass, a simple microprocessor interface and automatic ST-BUS® /GCI sensing to shorten setup time, aid in debugging and ease use of the device without sacrificing capabilities.

## FUNCTIONAL DESCRIPTION

### DATA AND CONNECTION MEMORY

All data that comes in through the RX inputs go through a serial-to-parallel conversion before being stored into internal Data Memory. The 8 KHz frame pulse (F32i) is used to mark the 125µs frame boundaries and to sequentially address the input channels in Data Memory.

Data output on the TX streams may come from either the serial input streams (Data Memory) or from the Connection Memory via the microprocessor or in the case that RX input data is to be output, the addresses in Connection Memory are used to specify a stream and channel of the input. The Connection Memory is setup in such a way that each location corresponds to an output channel for each particular stream. In that way, more than one channel can output the same data. In Processor Mode, the microprocessor writes data to the Connection Memory locations corresponding to the stream and channel that is to be output. The lower half (8 least significant bits) of the Connection Memory LOW is output every frame until the microprocessor changes the data or mode of the channels. By using this Processor Mode capability, the microprocessor can access input and output time-slots on a per-channel basis.

The three least significant bits of the Connection Memory HIGH are used to control per-channel mode of the output streams. The MOD2-0 bits are used to select Processor Mode, Constant or Variable Delay Mode, Bit Error Rate, and the High-Impedance state of output drivers. If the MOD2-0 bits are set to 1-1-1 accordingly, only that particular output channel (8 bits) will be in the High-Impedance state. If the MOD2-0 bits are set to 1-0-0 accordingly, that particular channel will be in Processor Mode. If the MOD2-0 bits are set to 1-0-1 a Bit Error Rate Test pattern will be transmitted for that time slot. See BERT section. If the

MOD2-0 bits are set to 0-0-1 accordingly, that particular channel will be in Constant Delay Mode. Finally, if the MOD2-0 bits are set to 0-0-0, that particular channel will be in Variable Delay Mode.

### SERIAL DATA INTERFACE TIMING

The master clock frequency of the IDT72V73273 is 32.768MHz, C32i. For 32.768Mb/s data rates, this results in a single-bit per clock. For 16.384Mb/s, 8.192Mb/s, 4.096Mb/s, and 2.048Mb/s this will result in two, four, eight, and sixteen clocks per bit, respectively. The IDT72V73273 provides two different interface timing modes, ST-BUS® or GCI. The IDT72V73273 automatically detects the polarity of an input frame pulse and identifies it as either ST-BUS® or GCI.

For 32.768Mb/s, in ST-BUS® Mode, data is clocked out on a falling edge and is clocked in on the subsequent rising-edge. For 16.384Mb/s, 8.192Mb/s, 4.096Mb/s, and 2.048Mb/s however there is not the typical associated clock since the IDT72V73273 accepts only a 32.768MHz clock. As a result there will be 2, 4, 8, and 16 clock between the 32.768Mb/s transmit edge and the subsequently transmit edges. Although in this is the case, the IDT72V73273 will appropriately transmit and sample on the proper edge as if the respective clock were present. See ST-BUS® Timing for detail.

For 32.768Mb/s, in GCI Mode, data is clocked out on a rising edge and is clocked in on the subsequent falling-edge. For 16.384Mb/s, 8.192Mb/s, 4.096Mb/s, and 2.048Mb/s however, again there is not the typical associated clock since the IDT72V73273 accepts only a 32.768MHz clock. As a result there will be 2, 4, 8, and 16 clocks between the 32.768Mb/s transmit edge and the other transmit edges. Although this is the case, the IDT72V73273 will appropriately transmit and sample on the proper edge as if the respective clock were present. See GCI Bus Timing for detail.

### DELAY THROUGH THE IDT72V73273

The switching of information from the input serial streams to the output serial streams results in a throughput delay. The device can be programmed to perform time-slot interchange functions with different throughput delay capabilities on a per-channel basis. For voice applications, variable throughput delay is best as it ensure minimum delay between input and output data. In wideband data applications, constant throughput delay is best as the frame integrity of the information is maintained through the switch.

The delay through the device varies according to the type of throughput delay selected in the MOD bits of the Connection Memory.

### VARIABLE DELAY MODE (MOD2-0 = 0-0-0)

In this mode, mostly for voice applications where minimum throughput delay is desired, delay is dependent on the combination of source and destination channels. The minimum delay achievable is a 3 channel periods of the slower data rate .

### CONSTANT DELAY MODE (MOD2-0 = 0-0-1)

In this mode, frame integrity is maintained in all switching configurations by making use of a multiple data memory buffer. Input channel data is written into the data memory buffers during frame n will be read out during frame n+2. In the IDT72V73273, the minimum throughput delay achievable in Constant Delay mode will be one frame plus one channel. See Table 14.

### MICROPROCESSOR INTERFACE

The IDT72V73273's microprocessor interface looks like a standard RAM interface to improve integration into a system. With a 16-bit address bus and a 16-bit data bus all memories can be accessed. Using the TSI microprocessor interface, reads and writes are mapped into Data and Connection memories. By allowing the internal memories to be randomly accessed, the controlling microprocessor has more time to manage other peripheral devices and can more easily and quickly gather information and setup the switch paths. Table 1 shows the mapping of the addresses into internal memory blocks. In order to minimize the amount of memory mapped space however, the Memory Select (MS1-0) bits in the Control Register must be written to first to select between the Connection Memory HIGH, the Connection Memory LOW, or Data Memory. Effectively, the Memory Select bits act as an internal mux to select between the Data Memory, Connection Memory HIGH, and Connection Memory LOW.

### MEMORY MAPPING

The address bus on the microprocessor interface selects the internal registers and memories of the IDT72V73273. The most significant bit of the address select between the registers and internal memories. See Table 1 for mappings.

As explained in the initialization sections, after system power-up, the TDRSR and RDRSR, should be programmed immediately to establish the desired switching configuration.

The data in the Control Register consists of the Software Reset, RX/TX Bypass, Output Enable Polarity, All Output Enable, Full Block Programming, Block Programming Data, Begin Block Programming Enable, Reset Connection Memory LOW in Block Programming, Output Standby, and Memory Select.

### SOFTWARE RESET

The Software Reset serves the same function as the hardware reset. As with the hard reset, the Software Reset must also be set HIGH for 20ns before bringing the Software Reset LOW again for normal operation. Once the Software Reset is LOW, internal registers and other memories may be read or written. During Software Reset, the microprocessor port is still able to read from all

internal memories. The only write operation allowed during a Software Reset is to the Software Reset bit in the Control Register to complete the Software Reset.

### CONNECTION MEMORY CONTROL

If the ODE pin and the Output Standby bit are LOW, all output channels will be in three-state. See Table 2 for detail.

If MOD2-0 of the Connection Memory HIGH is 1-0-0 accordingly, the output channel will be in Processor Mode. In this case the lower eight bits of the Connection Memory LOW are output each frame until the MOD2-0 bits are changed. If MOD2-0 of the Connection Memory HIGH are 0-0-1 accordingly, the channel will be in Constant Delay Mode and bits 14-0 are used to address a location in Data Memory. If MOD2-0 of the Connection Memory HIGH are 0-0-0, the channel will be in Variable Delay Mode and bits 14-0 are used to address a location in Data Memory. If MOD2-0 of the Connection Memory HIGH are 1-1-1, the channel will be in High-Impedance mode and that channel will be in three-state.

### RX/TX INTERNAL BYPASS

When the Bypass bit of control registers is 1, all RX streams will be "shorted" to TX in effect bypassing all internal circuitry of the TSI. This effectively sets the TSI to a 1-to-1 switch mode with minimal I/O delay. A zero can be written to allow normal operation. The intention of this mode is to minimize the delay from the RX input to the TX output making the TSI "invisible".

### INITIALIZATION OF THE IDT72V73273

After power up, the state of the Connection Memory is unknown. As such, the outputs should be put in High-Impedance by holding the ODE pin LOW. While the ODE is LOW, the microprocessor can initialize the device by using the Block Programming feature and program the active paths via the microprocessor bus. Once the device is configured, the ODE pin (or Output Standby bit depending on initialization) can be switched to enable the TSI switch.

**TABLE 1 — ADDRESS MAPPING**

A15	A14	A13	A12	A11	A10	A9	A8	A7	A6	A5	A4	A3	A2	A1	A0	R/W	Location	Hex Value
1	STA5	STA4	STA3	STA2	STA1	STA0	CH8	CH7	CH6	CH5	CH4	CH3	CH2	CH1	CH0	R/W	Internal memory (CM, DM (read only)) <sup>(1)</sup>	0x8000-0xFFFF
0	0	0	0	0	0	0	X	X	X	X	X	X	X	X	X	R/W	Control	0x00XX Register
0	0	0	0	0	0	1	X	X	X	X	X	X	X	X	X	R/W	TDRSR0	0x02XX
0	0	0	0	0	1	0	X	X	X	X	X	X	X	X	X	R/W	TDRSR1	0x04XX
0	0	0	0	0	1	1	X	X	X	X	X	X	X	X	X	R/W	RDRSR0	0x06XX
0	0	0	0	1	0	0	X	X	X	X	X	X	X	X	X	R/W	RDRSR1	0x08XX
0	0	0	0	1	0	1	X	X	X	X	X	X	X	X	X	R/W	BPSA	0x0AXX
0	0	0	0	1	1	0	X	X	X	X	X	X	X	X	X	R/W	BPEA	0x0CXX
0	0	0	0	1	1	1	X	X	X	X	X	X	X	X	X	R/W	BIS	0x0EXX
0	0	0	1	0	0	0	X	X	X	X	X	X	X	X	X	R/W	BER	0x10XX
0	0	1	0	0	0	0	X	X	X	X	X	X	X	X	X	R/W	FOR0	0x20XX
0	0	1	0	0	0	1	X	X	X	X	X	X	X	X	X	R/W	FOR1	0x22XX
0	0	1	0	0	1	0	X	X	X	X	X	X	X	X	X	R/W	FOR2	0x24XX
0	0	1	0	0	1	1	X	X	X	X	X	X	X	X	X	R/W	FOR3	0x26XX
0	0	1	0	1	0	0	X	X	X	X	X	X	X	X	X	R/W	FOR4	0x28XX
0	0	1	0	1	0	1	X	X	X	X	X	X	X	X	X	R/W	FOR5	0x2AXX
0	0	1	0	1	1	0	X	X	X	X	X	X	X	X	X	R/W	FOR6	0x2CXX
0	0	1	0	1	1	1	X	X	X	X	X	X	X	X	X	R/W	FOR7	0x2EXX
0	0	1	1	0	0	0	X	X	X	X	X	X	X	X	X	R/W	FOR8	0x30XX
0	0	1	1	0	0	1	X	X	X	X	X	X	X	X	X	R/W	FOR9	0x32XX
0	0	1	1	0	1	0	X	X	X	X	X	X	X	X	X	R/W	FOR10	0x34XX
0	0	1	1	0	1	1	X	X	X	X	X	X	X	X	X	R/W	FOR11	0x36XX
0	0	1	1	1	0	0	X	X	X	X	X	X	X	X	X	R/W	FOR12	0x38XX
0	0	1	1	1	0	1	X	X	X	X	X	X	X	X	X	R/W	FOR13	0x3AXX
0	0	1	1	1	1	0	X	X	X	X	X	X	X	X	X	R/W	FOR14	0x3CXX
0	0	1	1	1	1	1	X	X	X	X	X	X	X	X	X	R/W	FOR15	0x3EXX

**NOTE:**

1) Select Connection Memory High, Connection Memory Low, or Data Memory by setting the MS1-0 bits in the Control Register.

**TABLE 2 — OUTPUT HIGH-IMPEDANCE CONTROL**

MOD2-0 BITS IN CONNECTION MEMORY HIGH	OE X BIT OF TDRSR CONTROL REGISTER	ODE PIN	OSB BIT IN	OUTPUT DRIVER STATUS CONTROL REGISTER
1-1-1	1	X	X	Per Channel High-Impedance
Any, other than 1-1-1	1	0	0	All TX in High-Impedance
Any, other than 1-1-1	1	0	1	Enable
Any, other than 1-1-1	1	1	0	Enable
Any, other than 1-1-1	1	1	1	Enable
Any, other than 1-1-1	0	X	X	Group x of OEx is in High-Impedance

**NOTE:**

X = Don't Care.

**TABLE 3 — CONTROL REGISTER (CR) BITS**

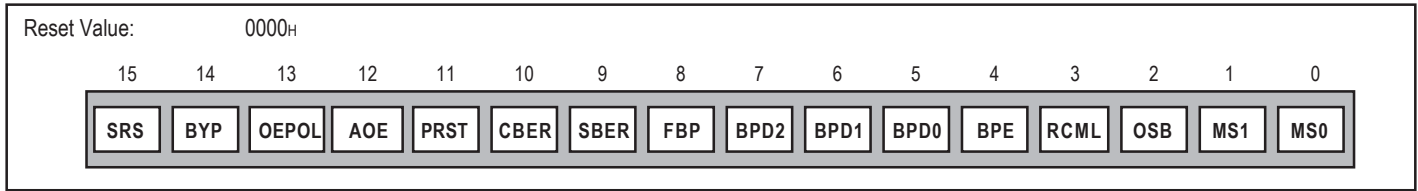

BIT	NAME	DESCRIPTION
15	SRS (Software Reset)	A one will reset the device and have the same effect as the $\overline{\text{RESET}}$ pin. Must be zero for normal operation.
14	BYP (RX/TX Bypass)	When the Bypass bit is 1, all RX streams will be “shorted” to TX-- in effect bypassing all internal circuitry of the TSI. This effectively sets the TSI to a 1-to-1 switch mode with almost only a few nanoseconds of delay. A zero can be written to allow normal operation. The intention of this mode is to minimize the delay from the RX input to the TX output making the TSI “invisible”. Any offset values in the FOR register will be required.
13	OEPOL (Output Enable Polarity)	When 1, a one on OEI pin denotes an active state on the output data stream; zero on OEI pin denotes High-Impedance state. When 0, a one denotes High-Impedance and a zero denotes an active state. OEI mode is entered on a per-group basis in the DRSR.
12	AOE (All Output Enable)	When 1, all output stream pin (TX <sub>n</sub> ) become OEI to allow for a two-chip solution for a larger switching matrix with OEI pins. When in AOE the DRS must be set to the corresponding data rates of the other device.
11	PRST (PRBS Reset)	When HIGH, the PRBS transmitter output will be initialized.
10	CBER (Clear Bit Error Rate)	A low to high transition of this bit clears the BER register (BERR).
9	SBER (Start Bit Error Rate)	A low to high transition in this bit starts the bit error rate test. The bit error test result is kept in the BER register (BERR).
8	FBP (Full Block Programming)	When 1, this bit overrides the BPSA and BPEA registers and programs the full Connection Memory space. When 0, the BPSA and BPEA determine the Connection Memory space to be programmed.
7-5	BPD2-0 (Block Programming Data)	These bits carry the value to be loaded into the Connection Memory block whenever the Connection Memory block programming feature is activated. After the BPE bit is set to 1 from 0, the contents of the bits BPD2-0 are loaded into bit 2, 1 and 0 (MOD2-0) of the Connection Memory HIGH.
4	BPE (Begin Block Programming Enable)	A zero to one transition of this bit enables the Connection Memory block programming feature delimited by the BPSA and BPEA registers as well as for a full back program. Once the BPE bit is set HIGH, the device will program the Connection Memory block as fast as than if the user manually programmed each Connection Memory location through the microprocessor. After the programming function has finished, the BPE bit returns to zero to indicate the operation has completed. When the BPE = 1, the BPE bit can be set to 0 to abort block programming.
3	RCML (Reset Connection Memory LOW in Block Programming)	When RCML = 1, all bits 14-0 in Connection Memory LOW will be reset to zero during block programming; when RCML=0, bits 14-0 in Connection Memory LOW will retain their original values during block programming.
2	OSB (Output Standby)	When ODE = 0 and OSB = 0, the output drivers of transmit serial streams are in High-Impedance mode. When either ODE = 1 or OSB = 1, the output serial stream drivers function normally.
1-0	MS1-0 (Memory Select)	These two bits decide which memory to be accessed via microprocessor port.  00 -- Connection Memory LOW 01 -- Connection Memory HIGH 10 -- Data Memory 11 -- Reserved

### MEMORY BLOCK PROGRAMMING

The IDT72V73273 provides users with the capability of initializing the entire Connection Memory block in two frames. To set bits 2,1 and 0 of every Connection Memory HIGH location, set the Full Block Program to 1, write the desired pattern in to the Block Programming Data Bits (BPD2-0), and enable the Block Program Enable bit. All of the block programming control can be found in the Control Register.

The block programming mode is enabled by setting the Block Program Enable bit of the Control Register HIGH. When the Block Programming Enable bit of the Control Register is set to HIGH, the Block Programming data will be loaded into the bits 2,1 and 0 of every Connection Memory HIGH location regardless of the selected data rate for the group. The Connection Memory LOW bits will be loaded with zeros when the Reset Connection Memory LOW (RCML) bit is enabled and is otherwise left untouched. When the memory block programming is complete, the device resets the Block Programming Enable and the BPD2-0 bits to zero.

The IDT72V73273 also incorporates a feature termed Group Block Programming. Group Block Programming, allows subsections of the Connection Memory to be block programmed as if the microprocessor were accessing the Connection Memory HIGH locations back-to-back fashion. This results in one Connection Memory High location being programmed for each 32i clock cycle. By having the TSI perform this function it allows the controlling microprocessor more time to perform other functions. Also, the TSI can be more efficient in

programming the locations since one CMH location is programmed every 32i clock cycle. The Group Block Programming function programs "Channel n" for all streams delineated by the group before going to "Channel n+1". A C-code representation is shown below. The Group Block Programming feature is composed of the Block Programming Start Address (BPSA), the Block Programming End Address (BPEA), and the BPE and BPD bits in the Control Register. The BPSA contains a start address for the block programming and BPEA contains an end address. The block programming will start at the start address and program until the end address even if the end address is "less" than the start address. In other words there is no mechanism to prevent a start address that is larger than the end address. If this occurs, the inverse CM locations in the given group are programmed resulting in a "wrap around" effect. This "wrap around" effect is independent for both the stream and channel addresses. This is illustrated in the Group Block Programming diagram see Figure 1 Group Block Programming. Users must not initiate a block program too close (ahead) of the present transmit locations. If this is done the TSI may simultaneously access the CM location that is being modified and unpredictable data on TX outputs may occur. Users should take care when using the group block programming feature. Users must not initiate a block program too close (ahead) of the present transmit location. If this is done the TSI may simultaneously access the CM location that is being modified and unpredictable data on TX outputs may occur. It should be noted however, in order to enable the Group Block Programming the Full Block Program (FBP) must be 0.

**TABLE 4 — BLOCK PROGRAMMING STARTING ADDRESS (BPSA) REGISTER**

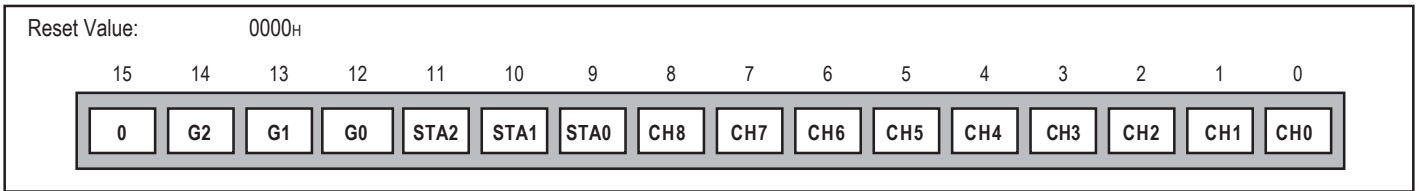

BIT	NAME	DESCRIPTION
15	Unused	Must be zero for normal operation.
14-12	G2-0 (Group Address bits 2-0)	These bits are used to select which group will be block programmed
11-9	STA2-0 (Stream Address bits 2-0)	These bits are used to select starting stream number for block programming.
8-0	CHA8-0 (Channel Address bits 8-0)	These bits are used to select starting channel number for block programming.

**TABLE 5 — BLOCK PROGRAMMING ENDING ADDRESS (BPEA) REGISTER**

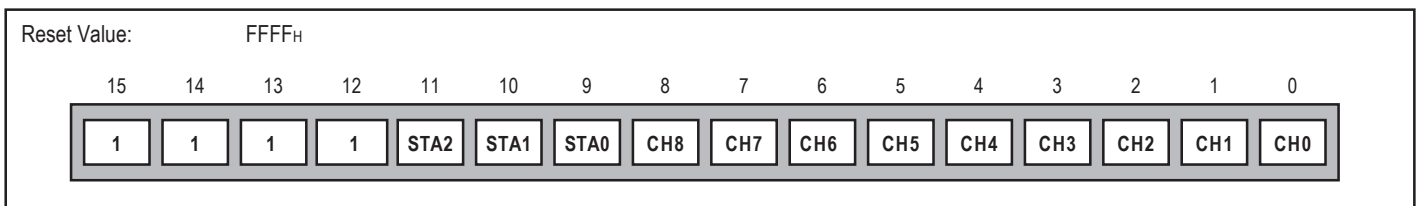

BIT	NAME	DESCRIPTION
15-12	Unused	Must be one for normal operation.
11-9	STA2-0 (Stream Address bits 2-0)	These bits are used to select ending stream number for burst programming.
8-0	CHA8-0 (Channel Address bits 8-0)	These bits are used to select starting channel number for burst programming.

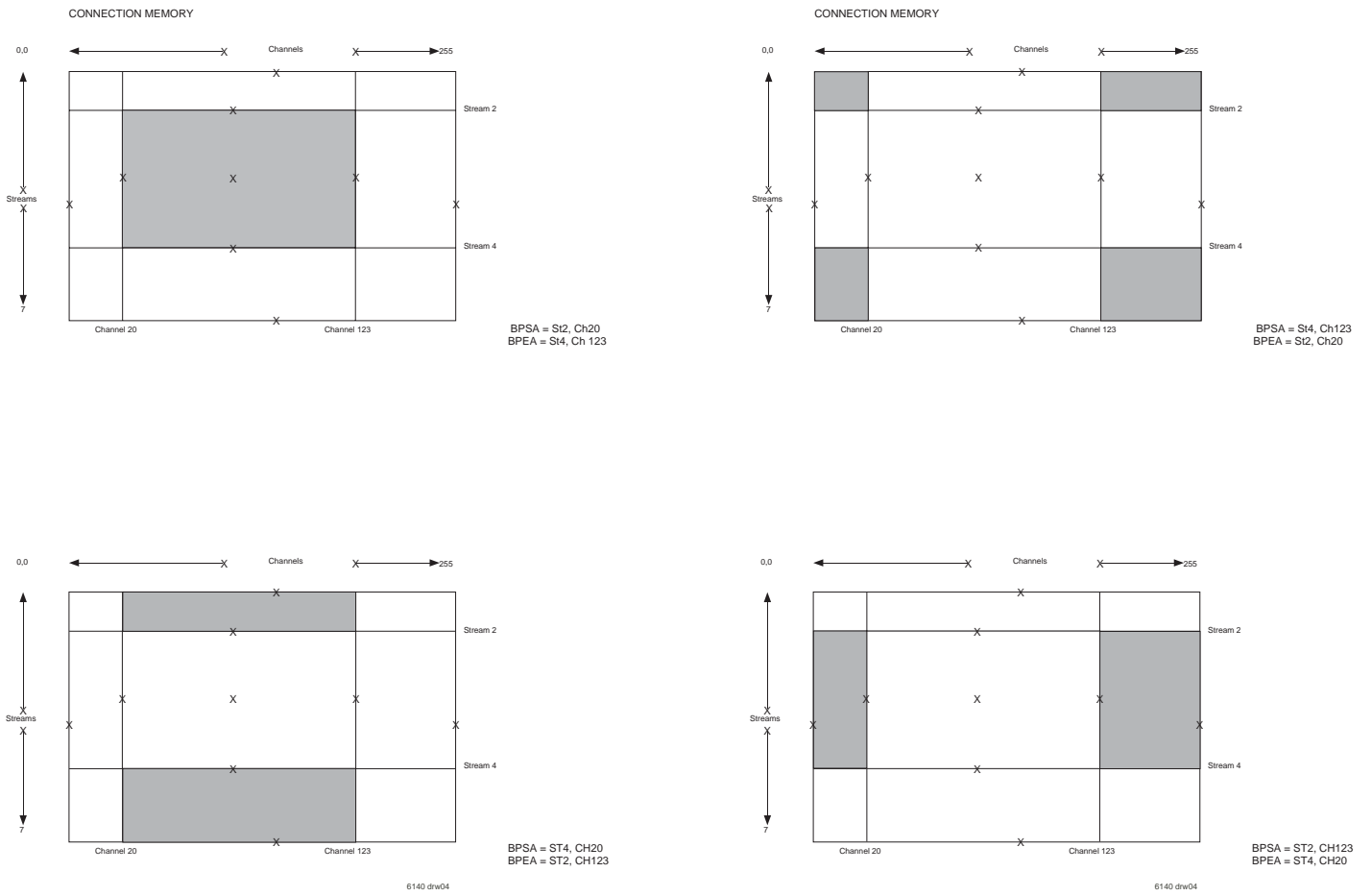

**NOTE:**  
 The group number is defined by the stream address in the BPSA.

Figure 1. Group Block Programming

```

int ST, CH
for (CH = StartChannel; CH <= EndChannel; CH++) {
  for (ST = StartStream; ST <= EndStream; ST++) {
    CMH[ST][CH] = BPD;
  }
}

```

**NOTE:**

This code is for illustrations purposes only. The IDT72V73273 is a HW instantiation of this kind of software.

**Figure 2. "Basic Instantiation"**

```

/* GroupNum is 0-7 */
/* GroupDataRate = 2, 4, 8, 16. or 32 (2Mb/s, 4Mb/s, 8Mb/s, 16Mb/s, 32Mb/s) */
functional BlockProgram (int GroupNum; int GroupDataRate) {
  int ST, CH;
  int MaxStream = ((GroupNum * 8) + 7);
  int MaxChannel = (((GroupDataRate/2) * 32) - 1);
  /* StartChannel <= EndChannel */
  if (StartChannel <= EndChannel) {
    for (CH = StartChannel; CH <= EndChannel; CH++) {
      /* StartStream <= EndStream and StartChannel <= EndChannel */
      if (StartStream <= EndStream) {
        for (ST = StartStream; ST <= EndStream; ST++) {
          CMH[ST][CH] = BPD;
        }
      }
      /* StartStream > EndStream and StartChannel <= EndChannel */
      else {
        for (ST = EndStream; ST <= MaxStream; ST++) {
          CMH [ST] [CH] = BPD;
        }
        for (ST = (GroupNum*7); ST <= StartStream; ST++) {
          CMH [ST] [CH] = BPD;
        }
      }
    }
  }
  /* End > Start Channel */
  else {
    /* The last part to be programmed */
    for (CH = EndChannel; CH <= MaxChannel; CH++) {
      /* StartStream > EndStream and StartChannel > EndChannel */
      if (StartStream <= EndStream) {
        for (ST = StartStream; ST <= EndStream; ST++) {
          CMH [ST] [CH] = BPD;
        }
      }
      /* StartStream > EndStream and StartChannel > EndChannel */
      else {
        for (ST = EndStream; ST <= MaxStream; ST++) {
          CHM [ST] [CH] = BPD;
        }
        for (ST = GroupNum*7); ST <= StartStream; ST++) {
          CMH [ST] [CH] = BPD;
        }
      }
    }
    /* The first part to be programmed */
    for (CH = 0; CH <= StartChannel; CH++) {
      /* StartStream > EndStream and StartChannel > EndChannel */
      if (StartStream <= EndStream) {
        for (ST = StartStream; ST <= EndStream; ST++) {
          CMH [ST] [CH] = BPD;
        }
      }
      /* StartStream > EndStream and StartChannel . EndChannel */
      else {
        for (ST = EndStream; ST <= MaxStream; ST++) {
          CMH [ST] [CH] = BPD;
        }
        for (ST = (GroupNum*7); ST <= StartStream; ST++) {
          CMH [ST] [CH] = BPD;
        }
      }
    }
  }
}

```

**NOTE:**

This code is for illustrations purposes only. The IDT72V73273 is a HW instantiation of this software.

**Figure 3. "Real" Instantiation of Memory Block Programming**

## BIT ERROR RATE

Pseudo-Random Bit Sequences (PRBS) can be independently transmitted and received. By setting the connection memory high bits to the BER transmit mode, that particular channel will transmit a BER pattern of the form  $2^{15}-1$ . For the receiver only one channel can be specified and monitored at a given time. By setting the BER Input Selection (BIS) to a given channel, every error in the BER sequence will be incremented by one.

If the more than  $2^{16}-1$  errors are encountered the BERR register will automatically overflow and be reset to zero. It is important to note that no interrupt or warning will be issued in this case. It is recommended that this register be

polled periodically and reset to prevent can overflow condition. To reset the Pseudo-random bit sequence and the error count registers set the PRST, CBER, and SBERR of the Control Register to high. See the Control Register for details.

Following a write to the BERR register a read of the BERR will result in the present value of the BERR data. Likewise, when the Clear Bit Rate bit (CBER) in the control register is activated, this will clear the internal BERR (iBERR).

As a general rule, a read of BERR should be preceded by a write to BERR. Again, it should be noted that the write to the BERR register will actually initiate a transfer from the iBERR to the BERR while the microprocessor data is ignored.

**TABLE 6 — BER INPUT SELECTION REGISTER (BIS)**

Reset Value:		Unknown (must be programmed)														
	15	14	13	12	11	10	9	8	7	6	5	4	3	2	1	0
	0	BG2	BG1	BG0	BSA2	BSA1	BSA0	BCA8	BCA7	BCA6	BCA5	BCA4	BCA3	BCA2	BCA1	BCA0

BIT	NAME	DESCRIPTION
15	Unused	Must be zero for normal operation
14-12	BG2-BG0 (BER Input Group Address Bits)	These bits refer to the input data group which receives the BER data.
11-9	BSA2-BSA0 (BER Input Stream Address Bits)	These bits refer to the input data stream which receives the BER data.
8-0	BCA8-BCA0 (Local BER Input Channel Address Bits)	These bits refer to the input channel which receives the BER data.

**TABLE 7 — BIT ERROR RATE REGISTER (BERR)**

Reset Value:		Unknown (must be programmed)														
	15	14	13	12	11	10	9	8	7	6	5	4	3	2	1	0
	BER15	BER14	BER13	BER12	BER11	BER10	BER9	BER8	BER7	BER6	BER5	BER4	BER3	BER2	BER1	BER0

BIT	NAME	DESCRIPTION
15-0	BER15-BER0 (Local Bit Error Rate Count Bits)	These bits refer to the local bit error counts.

**NOTE:**

Before a read of the BERR, a write to the BERR is necessary. As a read only register the write will have no effect. See the Bit Error Rate section for mor details

## INPUT FRAME OFFSET SELECTION

Input frame offset selection allows the channel alignment of individual input streams to be offset with respect to the output stream channel alignment. Although all input data comes in at the same speed, delays can be caused by variable path serial backplanes and variable path lengths which may be implemented in large centralized and distributed switching systems. Because data is often

delayed, this feature is useful in compensating for the skew between input streams.

Each input stream can have its own delay offset value by programming the frame input offset registers (FOR, Table 8). The maximum allowable skew is +7.5 clock periods forward with a resolution of  $\frac{1}{2}$  clock period, see Table 9. The output streams cannot be adjusted.

**TABLE 8 — FRAME INPUT OFFSET REGISTER (FOR) BITS**

Reset Value: 0000H.																
Register	15	14	13	12	11	10	9	8	7	6	5	4	3	2	1	0
FOR0 Register	OF32	OF31	OF30	DLE3	OF22	OF21	OF20	DLE2	OF12	OF11	OF10	DLE1	OF02	OF01	OF00	DLE0
FOR1 Register	OF72	OF71	OF70	DLE7	OF62	OF61	OF60	DLE6	OF52	OF51	OF50	DLE5	OF42	OF41	OF40	DLE4
FOR2 Register	OF112	OF111	OF110	DLE11	OF102	OF101	OF100	DLE10	OF92	OF91	OF90	DLE9	OF82	OF81	OF80	DLE8
FOR3 Register	OF152	OF151	OF150	DLE15	OF142	OF141	OF140	DLE14	OF132	OF131	OF130	DLE13	OF122	OF121	OF120	DLE12
FOR4 Register	OF192	OF191	OF190	DLE19	OF182	OF181	OF180	DLE18	OF172	OF171	OF170	DLE17	OD162	OD161	OF160	DLE16
FOR5 Register	OF232	OF231	OF230	DLE23	OF222	OF221	OF220	DLE22	OF212	OF211	OF210	DLE21	OF202	OF201	OF200	DLE20
FOR6 Register	OF272	OF271	OF270	DLE27	OF262	OF261	OF260	DLE26	OF252	OF251	OF250	DLE25	OF242	OF241	OF240	DLE24
FOR7 Register	OF312	OF311	OF310	DLE31	OF302	OF301	OF300	DLE30	OF292	OF291	OF290	DLE29	OF282	OF281	OF280	DLE28
FOR8 Register	OF352	OF351	OF350	DLE35	OF342	OF341	OF340	DLE34	OF332	OF331	OF330	DLE33	OF322	OF321	OF320	DLE32
FOR9 Register	OF392	OF391	OF390	DLE39	OF382	OF381	OF380	DLE38	OF372	OF371	OF370	DLE37	OF362	OF361	OF360	DLE36
FOR10 Register	OF432	OF431	OF430	DLE43	OF422	OF421	OF420	DLE42	OF412	OF411	OF410	DLE41	OF402	OF401	OF400	DLE40
FOR11 Register	OF472	OF471	OF470	DLE47	OF462	OF461	OF460	DLE46	OF452	OF451	OF450	DLE45	OF442	OF441	OF440	DLE44
FOR12 Register	OF512	OF511	OF510	DLE51	OF502	OF501	OF500	DLE50	OF492	OF491	OF490	DLE49	OF482	OF481	OF480	DLE48
FOR13 Register	OF552	OF551	OF550	DLE55	OF542	OF541	OF540	DLE54	OF532	OF531	OF530	DLE53	OF522	OF521	OF520	DLE52
FOR14 Register	OF592	OF591	OF590	DLE59	OF582	OF581	OF580	DLE58	OF572	OF571	OF570	DLE57	OF562	OF561	OF560	DLE56
FOR15 Register	OF632	OF631	OF630	DLE63	OF622	OF621	OF620	DLE62	OF612	OF611	OF610	DLE61	OF602	OF601	OF600	DLE60

NAME	DESCRIPTION
OFn2, OFn1, OFn0 (Offset Bits 2, 1 & 0)	These three bits define how long the serial interface receiver takes to recognize and store bit 0 from the RX input pin: i.e., to start a new frame. The input frame offset can be selected to +7.5 clock periods from the point where the external frame pulse input signal is applied to the FOi input of the device.
DLEn (Data Latch Edge)	ST-BUS® and GCI mode: DLEn = 0, offset is on the clock boundary. DLEn = 1, offset is a half cycle off of the clock boundary.

**TABLE 9 — OFFSET BITS (OFN2, OFN1, OFN0, DLEN) & FRAME DELAY BITS (FD11, FD2-0)**

INPUT STREAM OFFSET CLOCK PERIOD SHIFT BASED ON 32.768MHZ CLOCK					CORRESPONDING OFFSET BITS			
32.768Mb/s	16.384Mb/s	8.192Mb/s	4.096Mb/s	2.048Mb/s	OFn2	OFn1	OFn0	DLEn
None	None	None	None	None	0	0	0	0
+ 0.5	+ 1.0	+ 1.0	+ 2.0	+ 4.0	0	0	0	1
+ 1.0	+ 2.0	+ 2.0	+ 4.0	+ 8.0	0	0	1	0
+ 1.5	+ 3.0	+ 3.0	+ 6.0	+ 12.0	0	0	1	1
+ 2.0	+ 4.0	+ 4.0	+ 8.0	+ 16.0	0	1	0	0
+ 2.5	+ 5.0	+ 5.0	+ 10.0	+ 20.0	0	1	0	1
+ 3.0	+ 6.0	+ 6.0	+ 12.0	+ 24.0	0	1	1	0
+ 3.5	+ 7.0	+ 7.0	+ 14.0	+ 28.0	0	1	1	1
••••••••								
+ 7.5	+ 15.0	+ 15.0	+30.0	+ 60.0	1	1	1	1

Examples for Input Offset Delay Timing

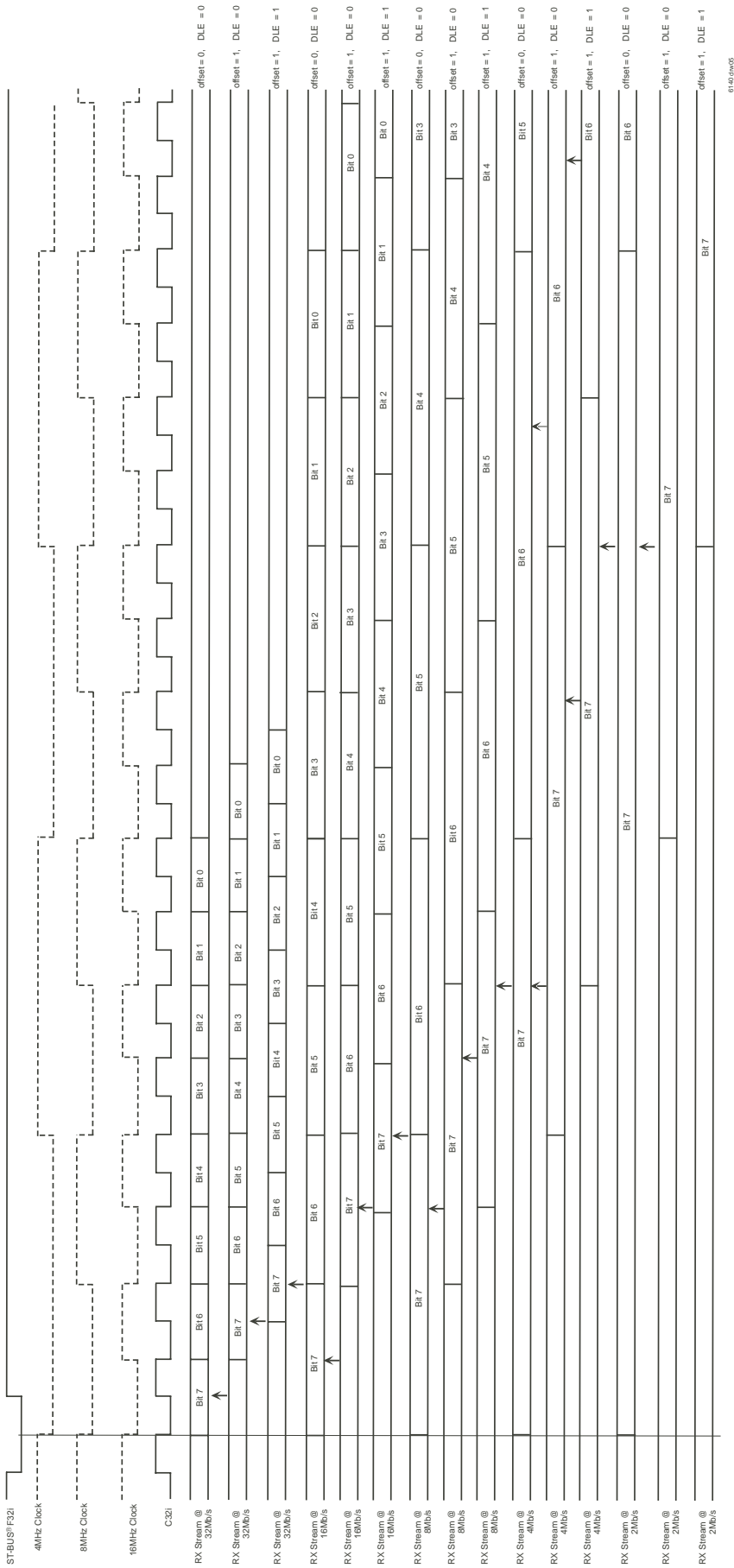

NOTE: denotes sample point of RX Data

Figure 4. ST-BUS® Offset Timing



**OUTPUT ENABLE INDICATION**

The IDT72V73273 has the capability to indicate the state of the outputs (active or three-state) by enabling the Output Enable Indication in the DRSR. In the

Output Enable Indication mode however, those output streams cannot be used to transmit CM or DM data only OE data. In the diagram below notice how the transmitting stream, TX0, is unaffected by the enabling and disabling of the OE stream (TX8).

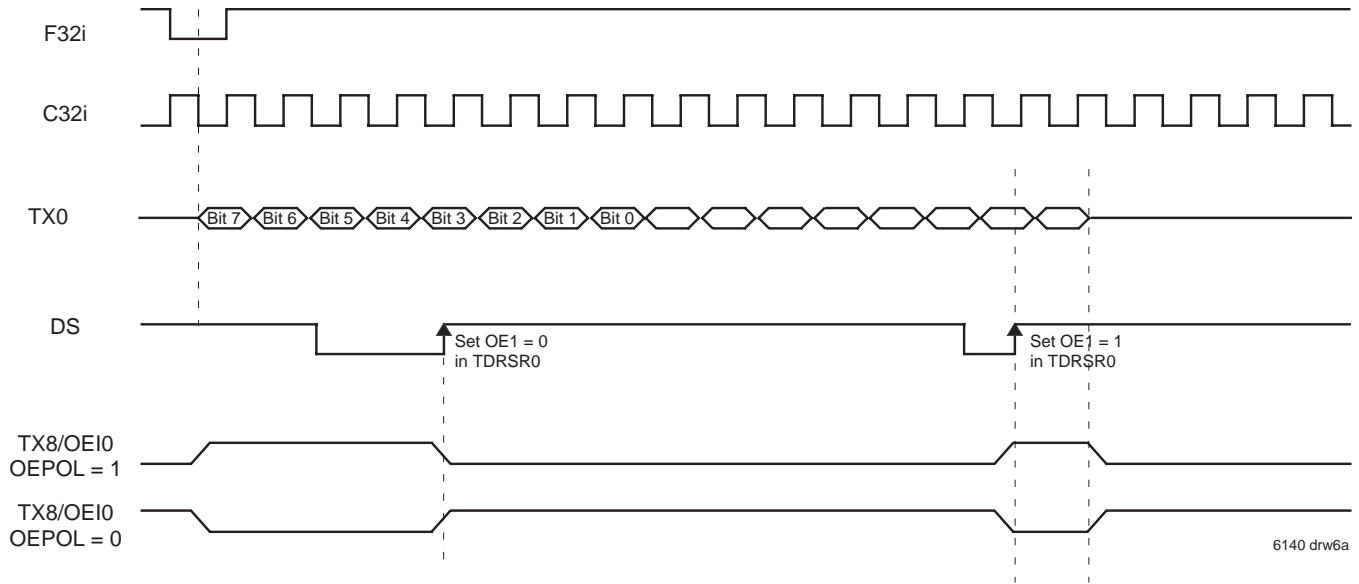

**NOTE:**

The TX0-7 pins are unaffected by the OE1 change.

*Figure 6. The Effect of Enabling and Disabling of the OE Bit in TDRSR*

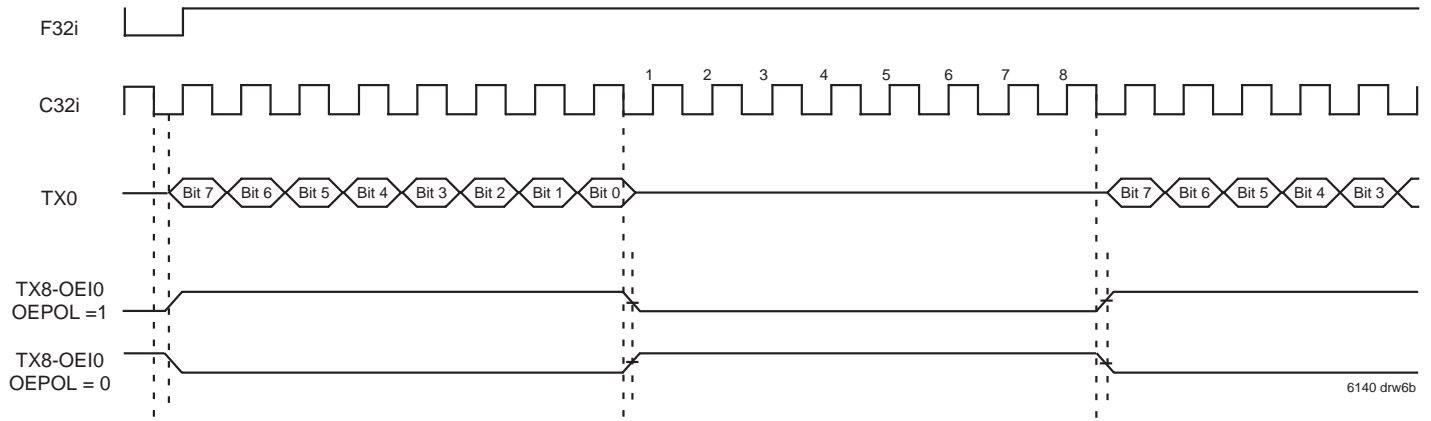

**NOTE:**  
 Group 0 is in 32Mb/s and Group 1 is in OEI Mode.

Figure 7. Group OE Operation

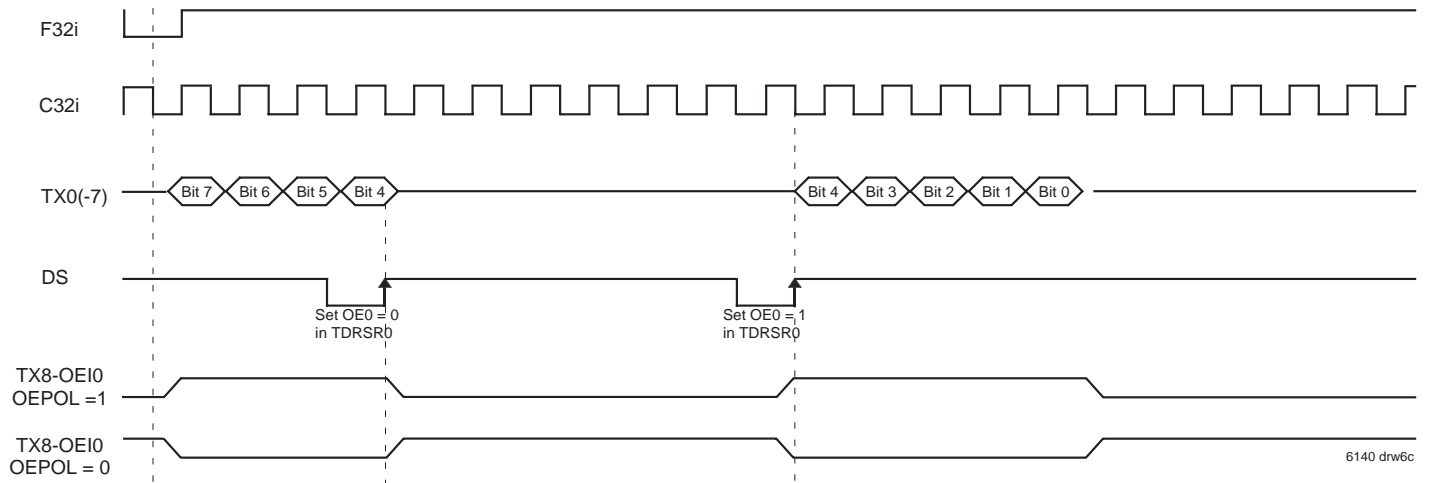

**NOTE:**  
 The OEI pins are unaffected by the OE0 change.

Figure 8. Group OE Operation

**TABLE 10 — TRANSMIT DATA RATE SELECTION REGISTER (TDRSR)**

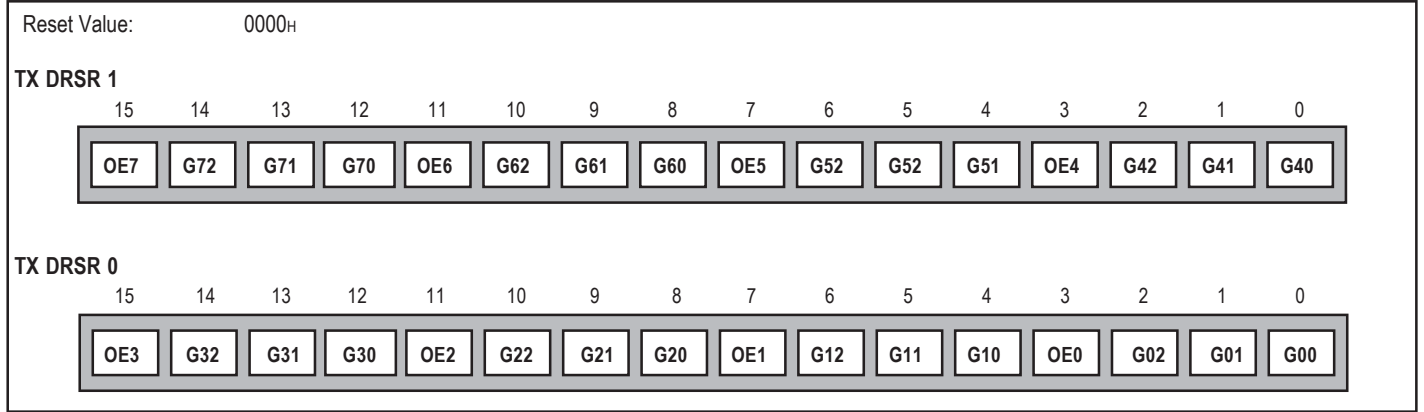

OE <sub>x</sub>	These bits can be used to High-Z the entire associated group. If OE <sub>x</sub> = 0 the group will be in High-Z. If OE <sub>x</sub> = 1, the group is in Low-Z (active state).																																				
G <sub>x2</sub> -G <sub>x0</sub>	These three group bits are used to select the transmit data rates for the eight groups of eight streams. See table 11 for data rates.																																				
	<table border="1" style="margin-left: auto; margin-right: auto; border-collapse: collapse;"> <thead> <tr> <th style="text-align: center;">G<sub>x2</sub><sup>(1)</sup></th> <th style="text-align: center;">G<sub>x1</sub><sup>(1)</sup></th> <th style="text-align: center;">G<sub>x0</sub><sup>(1)</sup></th> <th style="text-align: center;">Data Rate</th> </tr> </thead> <tbody> <tr><td style="text-align: center;">0</td><td style="text-align: center;">0</td><td style="text-align: center;">0</td><td style="text-align: center;">2.048Mb/s</td></tr> <tr><td style="text-align: center;">0</td><td style="text-align: center;">0</td><td style="text-align: center;">1</td><td style="text-align: center;">4.096Mb/s</td></tr> <tr><td style="text-align: center;">0</td><td style="text-align: center;">1</td><td style="text-align: center;">0</td><td style="text-align: center;">8.192Mb/s</td></tr> <tr><td style="text-align: center;">0</td><td style="text-align: center;">1</td><td style="text-align: center;">1</td><td style="text-align: center;">16.384Mb/s</td></tr> <tr><td style="text-align: center;">1</td><td style="text-align: center;">0</td><td style="text-align: center;">0</td><td style="text-align: center;">32.768Mb/s</td></tr> <tr><td style="text-align: center;">1</td><td style="text-align: center;">0</td><td style="text-align: center;">1</td><td style="text-align: center;">Reserved<sup>(1)</sup></td></tr> <tr><td style="text-align: center;">1</td><td style="text-align: center;">1</td><td style="text-align: center;">0</td><td style="text-align: center;">Reserved<sup>(1)</sup></td></tr> <tr><td style="text-align: center;">1</td><td style="text-align: center;">1</td><td style="text-align: center;">1</td><td style="text-align: center;">OEI<sup>(1)</sup></td></tr> </tbody> </table>	G <sub>x2</sub> <sup>(1)</sup>	G <sub>x1</sub> <sup>(1)</sup>	G <sub>x0</sub> <sup>(1)</sup>	Data Rate	0	0	0	2.048Mb/s	0	0	1	4.096Mb/s	0	1	0	8.192Mb/s	0	1	1	16.384Mb/s	1	0	0	32.768Mb/s	1	0	1	Reserved <sup>(1)</sup>	1	1	0	Reserved <sup>(1)</sup>	1	1	1	OEI <sup>(1)</sup>
G <sub>x2</sub> <sup>(1)</sup>	G <sub>x1</sub> <sup>(1)</sup>	G <sub>x0</sub> <sup>(1)</sup>	Data Rate																																		
0	0	0	2.048Mb/s																																		
0	0	1	4.096Mb/s																																		
0	1	0	8.192Mb/s																																		
0	1	1	16.384Mb/s																																		
1	0	0	32.768Mb/s																																		
1	0	1	Reserved <sup>(1)</sup>																																		
1	1	0	Reserved <sup>(1)</sup>																																		
1	1	1	OEI <sup>(1)</sup>																																		

**NOTES:**

1. "x" corresponds to groups 0-7 (8 Data streams per group).
2. If the G<sub>x2</sub>-0 are programmed to the reserved values the device will operate in the default 2.048Mb/s mode.
3. Only odd groups can be programmed for OEI. The OEI rate corresponds it's associated even group.

**TABLE 11 — TX GROUPING AND DATA RATES**

GROUP NUMBER	STREAMS	SPEED	WITH OEI=1
G0	0-7	2.048Mb/s-32.768Mb/s	2.048Mb/s-32.768Mb/s
G1	8-15	2.048Mb/s-32.768Mb/s	OEI<0-7>
G2	16-23	2.048Mb/s-32.768Mb/s	2.048Mb/s-32.768Mb/s
G3	24-31	2.048Mb/s-32.768Mb/s	OEI<16-23>
G4	32-39	2.048Mb/s-32.768Mb/s	2.048Mb/s-32.768Mb/s
G5	40-47	2.048Mb/s-32.768Mb/s	OEI<32-39>
G6	48-55	2.048Mb/s-32.768Mb/s	2.048Mb/s-32.768Mb/s
G7	56-63	2.048Mb/s-32.768Mb/s	OEI<48-55>

**TABLE 12 — RECEIVE DATA RATE SELECTION REGISTER(RDRSR)**

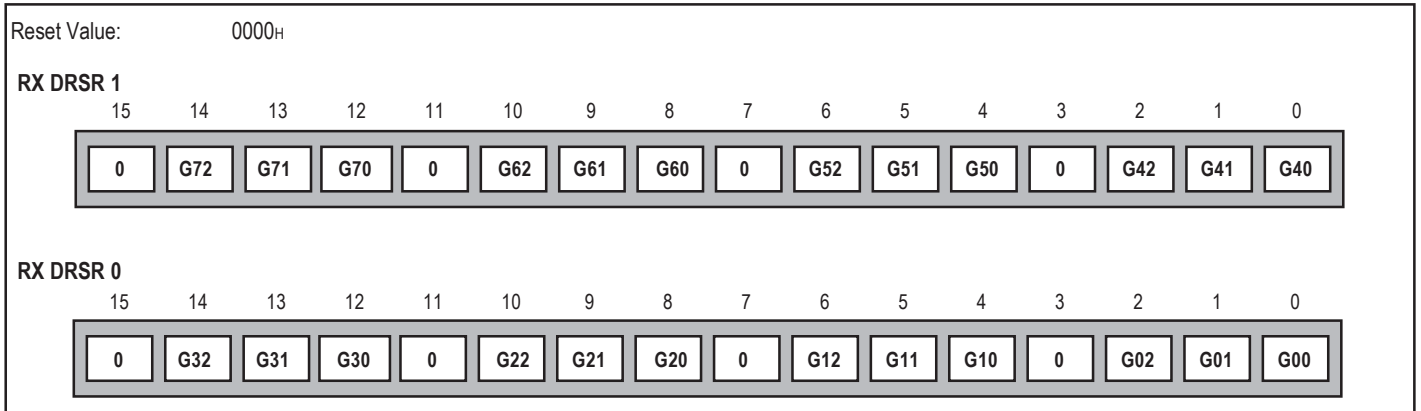

<b>Gx0-Gx2</b>	These three group bits are used to select the receive data rates for the eight groups of eight streams. See table 13 for data rates.			
	<u>Gx2</u> <sup>(1)</sup>	<u>Gx1</u> <sup>(1)</sup>	<u>Gx0</u> <sup>(1)</sup>	<u>Data Rate</u>
	0	0	0	2.048Mb/s
	0	0	1	4.096Mb/s
	0	1	0	8.192Mb/s
	0	1	1	16.384Mb/s
	1	0	0	32.768Mb/s
	1	0	1	Reserved <sup>(1)</sup>
	1	1	0	Reserved <sup>(1)</sup>
	1	1	1	Reserved <sup>(1)</sup>

**NOTES:**

1. "x" corresponds to groups 0-7 (8 Data streams per group).
2. If the Gx2-0 are programmed to the reserved values the device will operated in the default 2.048b/s mode.
3. Only odd groups can be programmed for OEI. The OEI rate corresponds to it's associated even group.

**TABLE 13 — RX GROUPING AND DATA RATES**

GROUP NUMBER	STREAMS	SPEED
G0	0-7	2.048Mb/s-32.768Mb/s
G1	8-15	2.048Mb/s-32.768Mb/s
G2	16-23	2.048Mb/s-32.768Mb/s
G3	24-31	2.048Mb/s-32.768Mb/s
G4	32-39	2.048Mb/s-32.768Mb/s
G5	40-47	2.048Mb/s-32.768Mb/s
G6	48-55	2.048Mb/s-32.768Mb/s
G7	56-63	2.048Mb/s-32.768Mb/s

**TABLE 14 — CONNECTION MEMORY HIGH**

Reset Value:		Unknown (must be programmed)															
		15	14	13	12	11	10	9	8	7	6	5	4	3	2	1	0
		0	0	0	0	0	0	0	0	0	0	0	0	0	MOD2	MOD1	MOD0

BIT	NAME	DESCRIPTION																																													
15-3	Unused	Must be zero for normal operation.																																													
2-0	MOD2-0	<table border="1"> <thead> <tr> <th>MOD2</th> <th>MOD1</th> <th>MOD0</th> <th>MODE</th> <th></th> </tr> </thead> <tbody> <tr> <td>0</td><td>0</td><td>0</td><td>0</td><td>Variable Delay Mode</td> </tr> <tr> <td>0</td><td>0</td><td>1</td><td>1</td><td>Constant Delay Mode</td> </tr> <tr> <td>0</td><td>1</td><td>0</td><td>0</td><td>Reserved</td> </tr> <tr> <td>0</td><td>1</td><td>1</td><td>1</td><td>Reserved</td> </tr> <tr> <td>1</td><td>0</td><td>0</td><td>0</td><td>Processor Mode</td> </tr> <tr> <td>1</td><td>0</td><td>1</td><td>1</td><td>Bit Error Rate Test</td> </tr> <tr> <td>1</td><td>1</td><td>0</td><td>0</td><td>Reserved</td> </tr> <tr> <td>1</td><td>1</td><td>1</td><td>1</td><td>High-Impedance</td> </tr> </tbody> </table>	MOD2	MOD1	MOD0	MODE		0	0	0	0	Variable Delay Mode	0	0	1	1	Constant Delay Mode	0	1	0	0	Reserved	0	1	1	1	Reserved	1	0	0	0	Processor Mode	1	0	1	1	Bit Error Rate Test	1	1	0	0	Reserved	1	1	1	1	High-Impedance
MOD2	MOD1	MOD0	MODE																																												
0	0	0	0	Variable Delay Mode																																											
0	0	1	1	Constant Delay Mode																																											
0	1	0	0	Reserved																																											
0	1	1	1	Reserved																																											
1	0	0	0	Processor Mode																																											
1	0	1	1	Bit Error Rate Test																																											
1	1	0	0	Reserved																																											
1	1	1	1	High-Impedance																																											

**TABLE 15 — CONNECTION MEMORY LOW**

Reset Value:		Unknown (must be programmed)															
		15	14	13	12	11	10	9	8	7	6	5	4	3	2	1	0
		0	SAB5	SAB4	SAB3	SAB2	SAB1	SAB0	CAB8	CAB7	CAB6	CAB5	CAB4	CAB3	CAB2	CAB1	CAB0

BIT	NAME	DESCRIPTION
15	Unused	Must be zero for normal operation
14-9	SAB5-0 (Source Stream Address Bits)	The binary value is the number of the data stream for the source of the connection.
8-0	CAB8-0 (Source Channel Address Bits)	The binary value is the number of the channel for the source of the connection.

**NOTES:**

- When running the device at lower bit rates (i.e. 2, 4, 8, or 16Mb/s), make sure the bits corresponding to the unused channels are set to 0.
- All streams can run at 32.768Mb/s simultaneously for the IDT72V73273.
- In processor mode, data in the lower byte (bits0-7) of the Connection Memory LOW will be outputted to the TX streams. The order in which the data are outputted will be starting from the LSB (Bit 0) to the MSB (Bit 7) - the lower byte. The figure below illustrates the sequence:

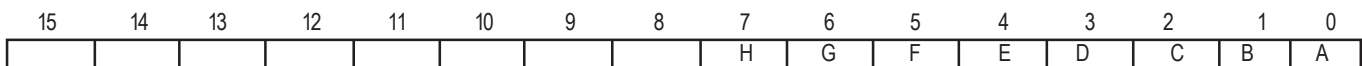

*Figure 9. Processor Mode Bit Sequencing*

**TABLE 16 — BOUNDARY SCAN REGISTER BITS**

Device Pin	Boundary Scan Bit 0 to 267		
	Input Scan Cell	Output Scan Cell	Three-state Control
ODE	0		
RESET	1		
C32i	2		
F32i	3		
S/A	4		
DS	5		
CS	6		
R/W	7		
A0	8		
A1	9		
A2	10		
A3	11		
A4	12		
A5	13		
A6	14		
A7	15		
A8	16		
A9	17		
A10	18		
A11	19		
A12	20		
A13	21		
A14	22		
A15	23		
BEL	24		
DTA/BEH	25	26	27
D15	28	29	30
D14	31	32	33
D13	34	35	36
D12	37	38	39
D11	40	41	42
D10	43	44	45
D9	46	47	48
D8	49	50	51
D7	52	53	54
D6	55	56	57
D5	58	59	60
D4	61	62	63
D3	64	65	66
D2	67	68	69
D1	70	71	72
D0	73	74	75
RX63	76		
RX62	77		
RX61	78		

Device Pin	Boundary Scan Bit 0 to 267		
	Input Scan Cell	Output Scan Cell	Three-state Control
RX60	79		
RX59	80		
RX58	81		
RX57	82		
RX56	83		
TX63/OE131		84	85
TX62/OE130		86	87
TX61/OE129		88	89
TX60/OE128		90	91
TX59/OE127		92	93
TX58/OE126		94	95
TX57/OE125		96	97
TX56/OE124		98	99
TX55/OE123		100	101
TX54/OE122		102	103
TX53/OE121		104	105
TX52/OE120		106	107
TX51/OE119		108	109
TX50/OE118		110	111
TX49/OE117		112	113
TX48/OE116		114	115
RX55	116		
RX54	117		
RX53	118		
RX52	119		
RX51	120		
RX50	121		
RX49	122		
RX48	123		
RX47	124		
RX46	125		
RX45	126		
RX44	127		
RX43	128		
RX42	129		
RX41	130		
RX40	131		
TX47/OE115		132	133
TX46/OE114		134	135
TX45/OE113		136	137
TX44/OE112		138	139
TX43/OE111		140	141
TX42/OE110		142	143
TX41/OE109		144	145
TX40/OE108		146	147

**TABLE 16 — BOUNDARY SCAN REGISTER BITS (CONTINUED)**

Device Pin	Boundary Scan Bit 0 to 267		
	Input Scan Cell	Output Scan Cell	Three-state Control
TX39/OEI7		148	149
TX38/OEI6		150	151
TX37/OEI5		152	153
TX36/OEI4		154	155
TX35/OEI3		156	157
TX34/OEI2		158	159
TX33/OEI1		160	161
TX32/OEI0		162	163
RX39	164		
RX38	165		
RX37	166		
RX36	167		
RX35	168		
RX34	169		
RX33	170		
RX32	171		
RX31	172		
RX30	173		
RX29	174		
RX28	175		
RX27	176		
RX26	177		
RX25	178		
RX24	179		
TX31		180	181
TX30		182	183
TX29		184	185
TX28		186	187
TX27		188	189
TX26		190	191
TX25		192	193
TX24		194	195
TX23		196	197
TX22		198	199
TX21		200	201
TX20		202	203
TX19		204	205
TX18		206	207
TX17		208	209
TX16		210	211
RX23	212		
RX22	213		
RX21	214		
RX20	215		

Device Pin	Boundary Scan Bit 0 to 267		
	Input Scan Cell	Output Scan Cell	Three-state Control
RX19	216		
RX18	217		
RX17	218		
RX16	219		
RX15	220		
RX14	221		
RX13	222		
RX12	223		
RX11	224		
RX10	225		
RX9	226		
RX8	227		
TX15		228	229
TX14		230	231
TX13		232	233
TX12		234	235
TX11		236	237
TX10		238	239
TX9		240	241
TX8		242	243
TX7		244	245
TX6		246	247
TX5		248	249
TX4		250	251
TX3		252	253
TX2		254	255
TX1		256	257
TX0		258	259
RX7	260		
RX6	261		
RX5	262		
RX4	263		
RX3	264		
RX2	265		
RX1	266		
RX0	267		

## JTAG SUPPORT

The IDT72V73273 JTAG interface conforms to the Boundary-Scan standard IEEE-1149.1. This standard specifies a design-for-testability technique called Boundary-Scan test (BST). The operation of the boundary-scan circuitry is controlled by an external test access port (TAP) Controller.

### TEST ACCESS PORT (TAP)

The Test Access Port (TAP) provides access to the test functions of the IDT72V73273. It consists of three input pins and one output pin.

- Test Clock Input (TCK)

TCK provides the clock for the test logic. The TCK does not interfere with any on-chip clock and thus remains independent. The TCK permits shifting of test data into or out of the Boundary-Scan register cells concurrently with the operation of the device and without interfering with the on-chip logic.

- Test Mode Select Input (TMS)

The logic signals received at the TMS input are interpreted by the TAP Controller to control the test operations. The TMS signals are sampled at the rising edge of the TCK pulse. This pin is internally pulled to VCC when it is not driven from an external source.

- Test Data Input (TDI)

Serial input data applied to this port is fed either into the instruction register or into a test data register, depending on the sequence previously applied to the TMS input. Both registers are described in a subsequent section. The received input data is sampled at the rising edge of TCK pulses. This pin is internally pulled to VCC when it is not driven from an external source.

- Test Data Output (TDO)

Depending on the sequence previously applied to the TMS input, the contents of either the instruction register or data register are serially shifted out through the TDO pin on the falling edge of each TCK pulse. When no data is shifted through the boundary scan cells, the TDO driver is set to a High-Impedance state.

- Test Reset (TRST)

Reset the JTAG scan structure. This pin is internally pulled to VCC when it is not driven from an external source.

### INSTRUCTION REGISTER

In accordance with the IEEE-1149.1 standard, the IDT72V73273 uses public instructions. The IDT72V73273 JTAG interface contains a four-bit instruction register. Instructions are serially loaded into the instruction register from the TDI when the TAP Controller is in its shift-IR state. Subsequently, the instructions are decoded to achieve two basic functions: to select the test data register that may operate while the instruction is current, and to define the serial test data register path, which is used to shift data between TDI and TDO during data register scanning. See Table 12 for Instruction decoding.

### TEST DATA REGISTER

As specified in IEEE-1149.1, the IDT72V73273 JTAG Interface contains two test data registers:

- The Boundary-Scan register

The Boundary-Scan register consists of a series of Boundary-Scan cells arranged to form a scan path around the boundary of the IDT72V73273 core logic.

- The Bypass Register

The Bypass register is a single stage shift register that provides a one-bit path from TDI to TDO. The IDT72V73273 boundary scan register bits are shown in Table 14. Bit 0 is the first bit clocked out. All three-state enable bits are active HIGH.

### ID CODE REGISTER

As specified in IEEE-1149.1, this instruction loads the IDR with the Revision Number, Device ID, JEDEC ID, and ID Register Indicator Bit. See Table 10.

**TABLE 17 — IDENTIFICATION REGISTER DEFINITIONS**

INSTRUCTION FIELD	VALUE	DESCRIPTION
Revision Number (31:28)	0x0	Reserved for version number
IDT Device ID (27:12)	0x0430	Defines IDT part number
IDT JEDEC ID (11:1)	0x33	Allows unique identification of device vendor as IDT
ID Register Indicator Bit (Bit 0)	1	Indicates the presence of an ID register

**TABLE 18 — SCAN REGISTER SIZES**

REGISTER NAME	BIT SIZE
Instruction (IR)	4
Bypass (BYR)	1
Identification (IDR)	32
Boundary Scan (BSR)	Note(1)

**NOTES:**

1. The Boundary Scan Descriptive Language (BSDL) file for this device is available on the IDT website ([www.idt.com](http://www.idt.com)), or by contacting your local IDT sales representative.

**TABLE 19 — SYSTEM INTERFACE PARAMETERS**

INSTRUCTION	CODE	DESCRIPTION
EXTEST	0000	Forces contents of the boundary scan cells onto the device outputs <sup>(1)</sup> . Places the boundary scan register (BSR) between TDI and TDO.
BYPASS	1111	Places the bypass register (BYR) between TDI and TDO.
IDCODE	0010	Loads the ID register (IDR) with the vendor ID code and places the register between TDI and TDO.
HIGH-Z	0011	Places the bypass register (BYR) between TDI and TDO. Forces all device output drivers to a High-Z state.
SAMPLE/PRELOAD	0001	Places the boundary scan register (BSR) between TDI and TDO. SAMPLE allows data from device inputs <sup>(2)</sup> and outputs <sup>(1)</sup> to be captured in the boundary scan cells and shifted serially through TDO. PRELOAD allows data to be input serially into the boundary scan cells via the TDI.
RESERVED	All other codes	Several combinations are reserved. Do not use other codes than those identified above.

**NOTES:**

1. Device outputs = All device outputs except TDO.
2. Device inputs = All device inputs except TDI, TMS and  $\overline{\text{TRST}}$ .

**TABLE 20 — JTAG AC ELECTRICAL CHARACTERISTICS (1,2,3,4)**

SYMBOL	PARAMETER	MIN.	MAX.	UNITS
t <sub>CYC</sub>	JTAG Clock Input Period	100	—	ns
t <sub>CH</sub>	JTAG Clock HIGH	40	—	ns
t <sub>CL</sub>	JTAG Clock LOW	40	—	ns
t <sub>IR</sub>	JTAG Clock Rise Time	—	3 <sup>(1)</sup>	ns
t <sub>IF</sub>	JTAG Clock Fall Time	—	3 <sup>(1)</sup>	ns
t <sub>JRST</sub>	JTAG Reset	50	—	ns
t <sub>JRSR</sub>	JTAG Reset Recovery	50	—	ns
t <sub>CD</sub>	JTAG Data Output	—	25	ns
t <sub>DC</sub>	JTAG Data Output Hold	0	—	ns
t <sub>S</sub>	JTAG Setup	15	—	ns
t <sub>H</sub>	JTAG Hold	15	—	ns

**NOTES:**

1. Guaranteed by design.
2. 30pF loading on external output signals.
3. Refer to AC Electrical Test Conditions stated earlier in this document.
4. JTAG operations occur at one speed (10MHz). The base device may run at any speed specified in this datasheet.

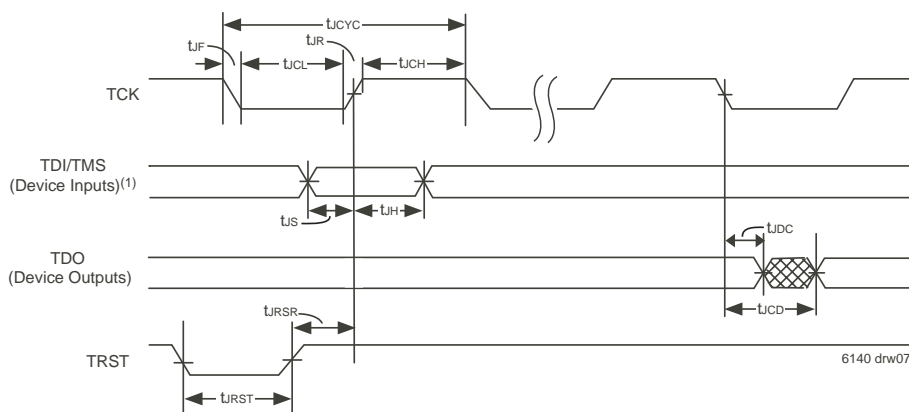

**NOTE:**

1. Device inputs = All device inputs except TDI, TMS and  $\overline{\text{TRST}}$ .

**Figure 10. JTAG Timing Specifications**

### ABSOLUTE MAXIMUM RATINGS<sup>(1)</sup>

Symbol	Parameter	Min.	Max.	Unit
V <sub>CC</sub>	Supply Voltage	-0.5	+4.0	V
V <sub>i</sub>	Voltage on Digital Inputs	GND -0.3	V <sub>CC</sub> +0.3	V
I <sub>o</sub>	Current at Digital Outputs	-50	50	mA
T <sub>s</sub>	Storage Temperature	-55	+125	°C
P <sub>D</sub>	Package Power Dissipation	—	2	W

**NOTE:**

1. Exceeding these values may cause permanent damage. Functional operation under these conditions is not implied.

### RECOMMENDED OPERATING CONDITIONS<sup>(1)</sup>

Symbol	Parameter	Min.	Typ.	Max.	Unit
V <sub>CC</sub>	Positive Supply	3.0	3.3	3.6	V
V <sub>IH</sub> <sup>(1)</sup>	Input HIGH Voltage	2.0	—	V <sub>CC</sub>	V
V <sub>IL</sub>	Input LOW Voltage	-0.3	—	0.8	V
T <sub>OP</sub>	Operating Temperature Industrial	-40	25	+85	°C

**NOTES:**

1. Input/Outputs are not 5V tolerant.  
2. Voltages are with respect to ground (GND) unless otherwise stated.

### DC ELECTRICAL CHARACTERISTICS

Symbol	Parameter	Min.	Typ.	Max.	Units
I <sub>CC</sub> <sup>(2)</sup>	Supply Current	—	—	380	mA
I <sub>IL</sub> <sup>(3,4)</sup>	Input Leakage (input pins)	—	—	60	μA
I <sub>BL</sub> <sup>(3,4)</sup>	Input Leakage (I/O pins)	—	—	60	μA
I <sub>oZ</sub> <sup>(3,4)</sup>	High-Impedance Leakage	—	—	60	μA
V <sub>OH</sub> <sup>(5)</sup>	Output HIGH Voltage	2.4	—	—	V
V <sub>OL</sub> <sup>(6)</sup>	Output LOW Voltage	—	—	0.4	V

**NOTES:**

1. Voltages are with respect to ground (GND) unless otherwise stated.  
2. Outputs unloaded.  
3.  $0 \leq V \leq V_{CC}$ .  
4. Maximum leakage on pins (output or I/O pins in High-Impedance state) is over an applied voltage (V).  
5. I<sub>OH</sub> = 10 mA.  
6. I<sub>OL</sub> = 10 mA.

### AC ELECTRICAL CHARACTERISTICS - TIMING PARAMETER MEASUREMENT VOLTAGE LEVELS

Symbol	Rating	Level	Unit
V <sub>TT</sub>	TTL Threshold	1.5	V
V <sub>HM</sub>	TTL Rise/Fall Threshold Voltage HIGH	2.0	V
V <sub>LM</sub>	TTL Rise/Fall Threshold Voltage LOW	0.8	V
	Input Pulse Levels		V
t <sub>r,f</sub>	Input Rise/Fall Times	1	ns
	Input Timing Reference Levels		V
	Output Reference Levels		V
C <sub>L</sub> <sup>(1)</sup>	Output Load	50	pF

**NOTE:**

1. JTAG C<sub>L</sub> is 30pF

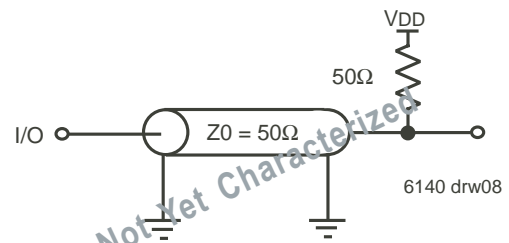

Figure 11. AC Termination

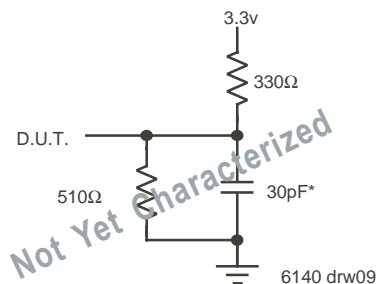

Figure 12. AC Test Load

### AC ELECTRICAL CHARACTERISTICS - RESET AND ODE TIMING

Symbol	Parameter	Min.	Typ.	Max.	Units
t <sub>ODEZ</sub>	Output Driver Enable (ODE) to Low-Z	6	—	—	ns
t <sub>RS</sub>	Reset Pulse Width	20	—	—	ns
t <sub>RZ</sub>	Active to High-Z on Master Reset	—	—	12	ns

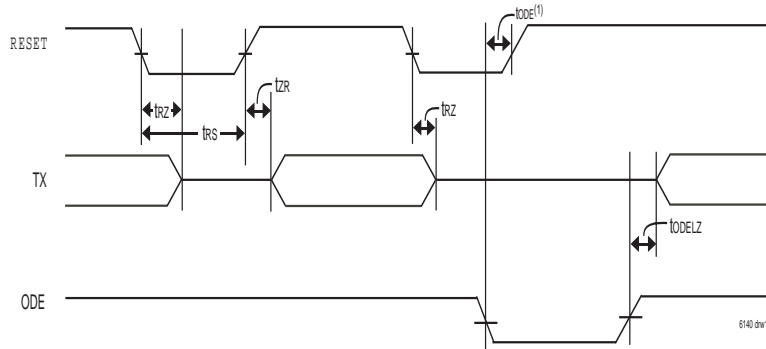

Figure 13. Reset and ODE Timing

### AC ELECTRICAL CHARACTERISTICS - C32i AND ODE TO HIGH-Z TIMING AND C32i AND ODE TO LOW-Z TIMING

Symbol	Parameter	Min.	Typ.	Max.	Units
t <sub>CLZ</sub> <sup>(1)</sup>	Clock to Low-Z	3	—	—	ns
t <sub>CHZ</sub> <sup>(1)</sup>	Clock to High-Z	—	—	9	ns
t <sub>ODEA</sub>	ODE to Valid Data	6	—	—	ns
t <sub>ODEHZ</sub>	Output Driver Enable (ODE) to High-Z	3	—	9	ns
t <sub>ODELZ</sub>	Output Driver Enable (ODE) to Low-Z	4	—	—	ns
t <sub>SIH</sub> <sup>(1)</sup>	RX Hold Time	4	—	—	ns
t <sub>SOD</sub>	Clock to Valid Data	3	7	9	ns

NOTE:  
 1. C<sub>L</sub> = 30pF

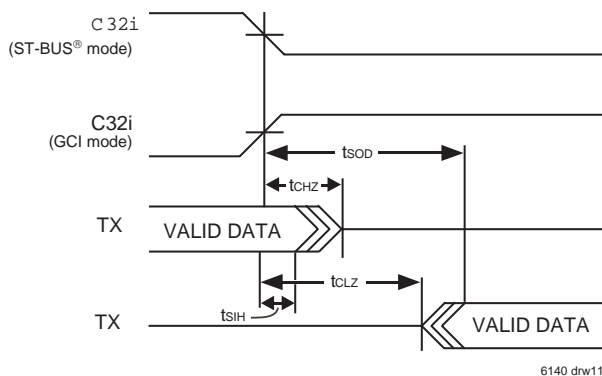

Figure 14. Serial Output and External Control

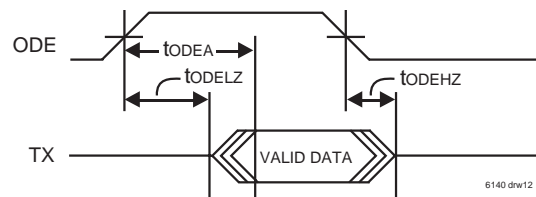

Figure 15. Output Driver Enable (ODE)

## AC ELECTRICAL CHARACTERISTICS - ST-BUS® TIMING

Symbol	Parameter	Min.	Typ.	Max.	Units
t <sub>CH</sub>	C32i Pulse Width HIGH Clock rate = 32.768Mb/s	13	15.25	17	ns
t <sub>CL</sub>	C32i Pulse Width LOW Clock rate = 32.768Mb/s	13	15.25	17	ns
t <sub>CP</sub>	C32i Period Clock rate = 32.768Mb/s	29	30.5	35	ns
t <sub>FPH</sub>	Frame Pulse Hold Time from C32i falling (ST-BUS® or GCI)	5	—	—	ns
t <sub>FPS</sub>	Frame Pulse Setup time before C32i falling (ST-BUS® or GCI)	5	—	—	ns
t <sub>FPW</sub>	Frame Pulse Width (ST-BUS®, GCI) Clock rate = 32.768Mb/s	13	—	31	ns
t <sub>r,tf(1)</sub>	Clock Rise/Fall Time	—	1	—	ns
t <sub>SIH</sub>	RX Hold Time	4	—	—	ns
t <sub>SIS</sub>	RX Setup Time	2	—	—	ns
t <sub>SOD</sub>	Clock to Valid Data	3	7	9	ns

**NOTE:**

1. Parameters verified under test conditions.

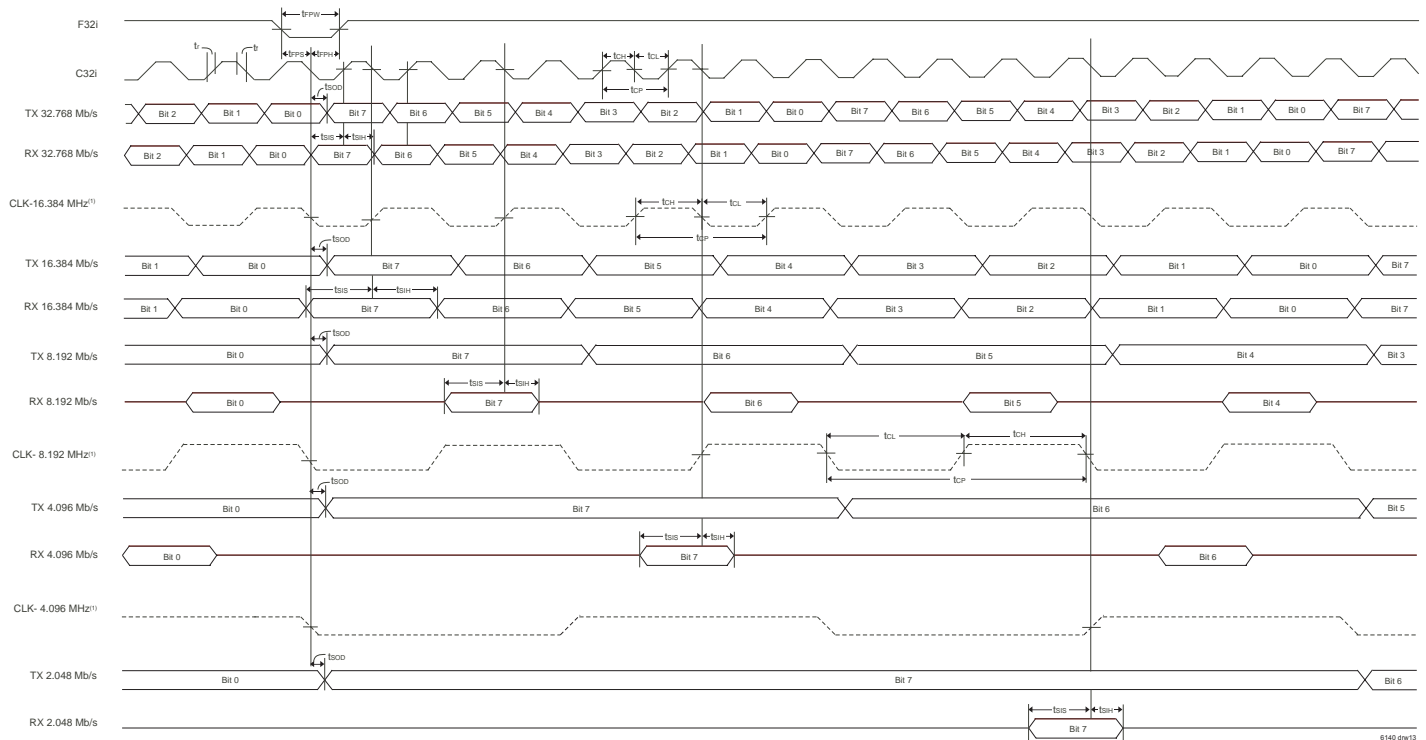

**NOTE:**

1. These clocks are for reference purposes only.  
 The TSI only accepts a 32.768MHz clock.

Figure 16 ST-BUS® Timing

### AC ELECTRICAL CHARACTERISTICS - GCI BUS TIMING

Symbol	Parameter	Min.	Typ.	Max.	Units
t <sub>CH</sub>	C32i Pulse Width HIGH Clock rate = 32.768Mb/s	13	15.25	17	ns
t <sub>CL</sub>	C32i Pulse Width LOW Clock rate = 32.768Mb/s	13	15.25	17	ns
t <sub>CP</sub>	C32i Period Clock rate = 32.768Mb/s	29	30.5	35	ns
t <sub>FPH</sub>	Frame Pulse Hold Time from C32i falling (ST-BUS® or GCI)	5	—	—	ns
t <sub>FPS</sub>	Frame Pulse Setup Time before C32i falling (ST-BUS® or GCI)	5	—	—	ns
t <sub>FPW</sub>	Frame Pulse Width (ST-BUS®, GCI) Clock rate = 32.768Mb/s	13	—	31	ns
t <sub>r,tf</sub>	Clock Rise/Fall Time	—	1	—	ns
t <sub>SIH</sub>	RX Hold Time	4	—	—	ns
t <sub>SIS</sub>	RX Setup Time	2	—	—	ns
t <sub>SOD</sub>	Clock to Valid Data	3	7	9	ns

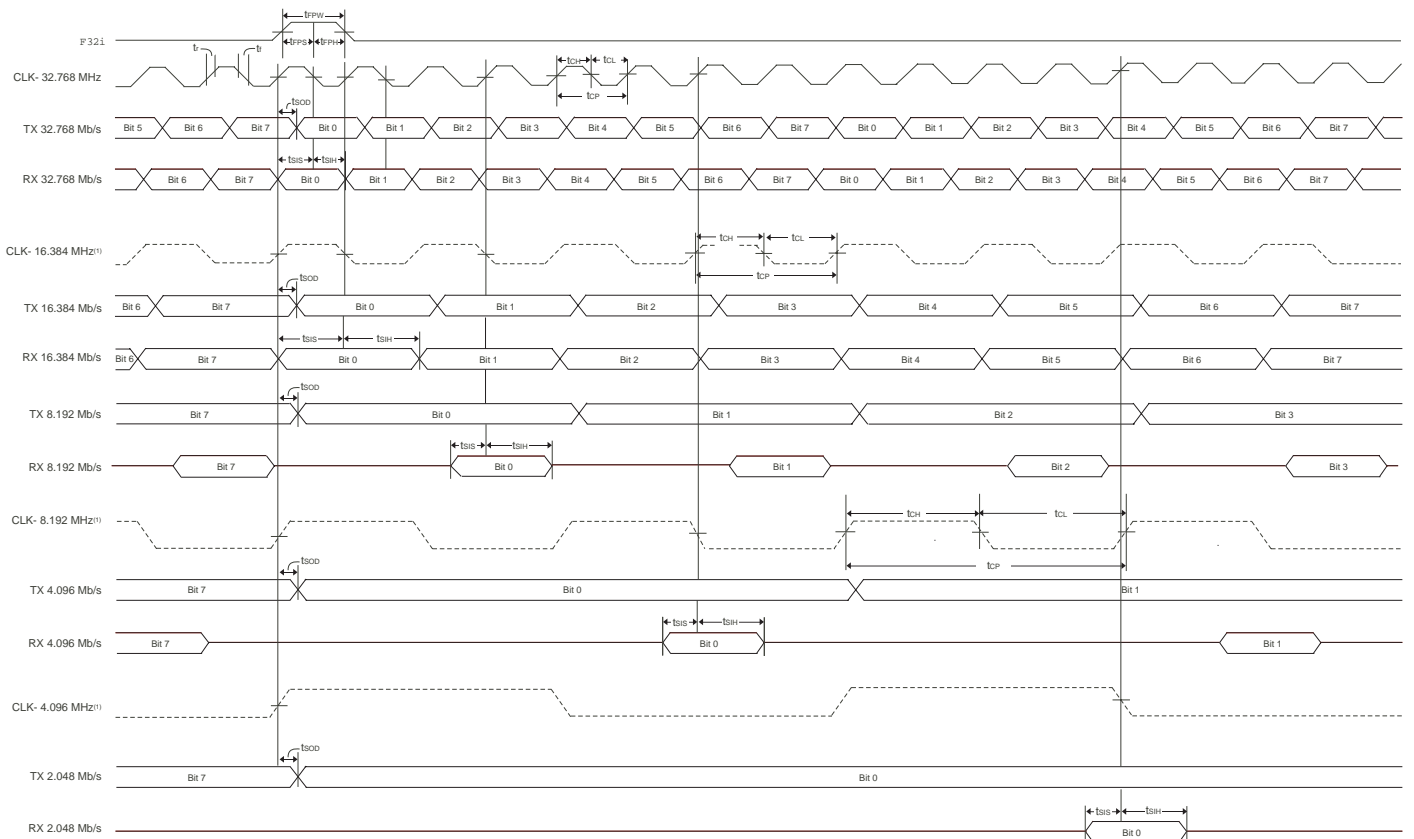

**NOTE:**  
 1. These clocks are for reference purposes only.  
 The TSI only accepts a 32.768MHz clock.

Figure 17. GCI Bus Timing

### AC ELECTRICAL CHARACTERISTICS - OEI BUS TIMING IN ST-BUS® MODE

Symbol	Parameter	Min.	Typ.	Max.	Units
t <sub>CH</sub>	C32i Pulse Width HIGH Clock rate = 32.768Mb/s	13	15.25	17	ns
t <sub>CHZ</sub> <sup>(2)</sup>	Clock to High-Z	—	—	9	ns
t <sub>CL</sub>	C32i Pulse Width LOW Clock rate = 32.768Mb/s	13	15.25	17	ns
t <sub>CLZ</sub> <sup>(2)</sup>	Clock to Low-Z	3	—	—	ns
t <sub>CP</sub>	C32i Period Clock rate = 32.768Mb/s	29	30.5	35	ns
t <sub>FPH</sub>	Frame Pulse Hold Time from C32i falling (ST-BUS® or GCI)	5	—	—	ns
t <sub>FPS</sub>	Frame Pulse Setup Time before C32i falling (ST-BUS® or GCI)	5	—	—	ns
t <sub>FPW</sub>	Frame Pulse Width (ST-BUS®, GCI) Clock rate = 32.768Mb/s	13	—	31	ns
t <sub>OEIE</sub>	Clock to OEI Enable	3	—	9	ns
t <sub>OEID</sub>	Clock to OEI disable	3	—	9	ns
t <sub>r</sub> , t <sub>f</sub> <sup>(1)</sup>	Clock Rise/Fall Time	—	1	—	ns
t <sub>SOD</sub>	Clock to Valid Data	3	7	9	ns

**NOTES:**

- Parameters verified under test conditions.
- C<sub>L</sub> = 300pF

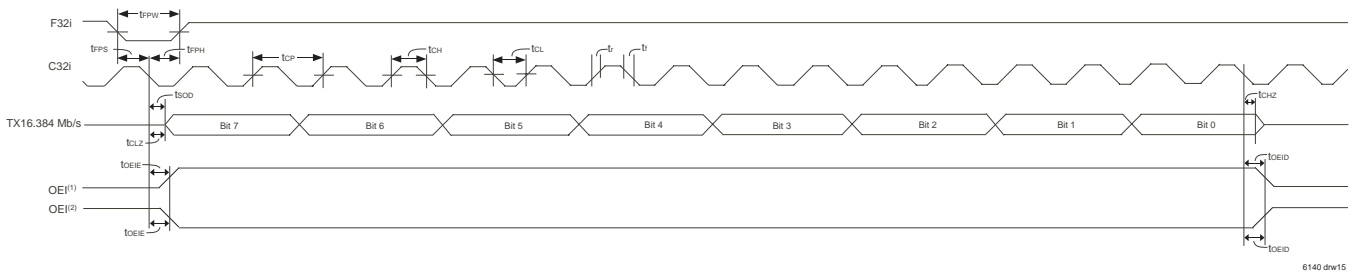

**NOTES:**

- OEPOL = 1
- OEPOL = 0

Figure 18. OEI Bus Timing in ST-BUS® Mode

**AC ELECTRICAL CHARACTERISTICS - RX TO TX INTERNAL BYPASS BIT**

Symbol	Parameter	Min.	Typ.	Max.	Units
$t_{bc}$		2	8	12	ns

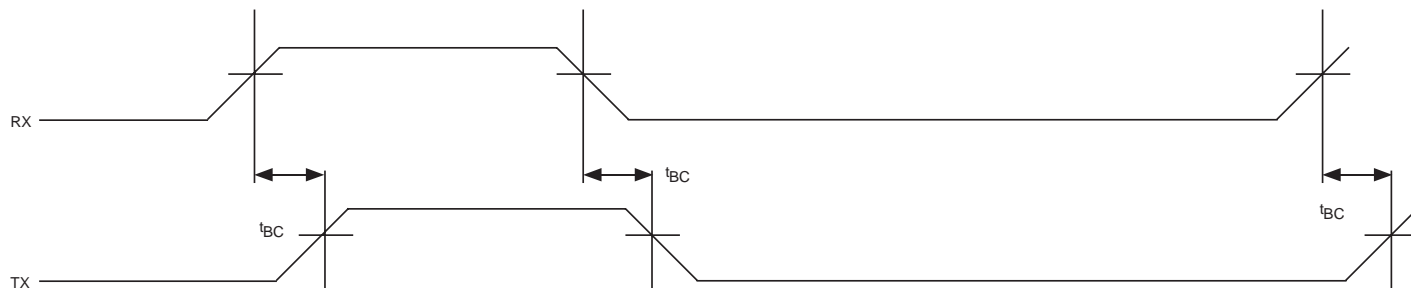

6140 drw16

$t_{bc}$  = end to end chip delay

Figure 19 . RX to TX Internal Bypass Bit

### AC ELECTRICAL CHARACTERISTICS - MOTOROLA NON-MULTIPLEXED BUS ASYNCHRONOUS TIMING MEMORY ACCESS

SYMBOL	PARAMETER	MIN.	TYP.	MAX.	UNITS
tADH	Address Hold after $\overline{DS}$ Rising	2	—	—	ns
tADS	Address Setup from $\overline{DS}$ Falling	2	—	—	ns
tAKD <sup>(1)</sup>	Acknowledgement Delay: Reading/Writing Memory	—	—	30	ns
tAKH <sup>(1,2,3)</sup>	Acknowledgement Hold Time	—	—	10	ns
tCSH	$\overline{CS}$ Hold after $\overline{DS}$ Rising	0	—	—	ns
tCSS	$\overline{CS}$ Setup from $\overline{DS}$ Falling	0	—	—	ns
tDDR <sup>(1)</sup>	Data Setup from $\overline{DTA}$ LOW on Read	2	—	—	ns
tDHR <sup>(1,2,3)</sup>	Data Hold on Read	10	15	25	ns
tDHW	Data Hold on Write	5	—	—	ns
tDSS	Data Strobe Setup Time	2	—	—	ns
tDSPW	Data Strobe Pulse Width	6	—	—	ns
tRWH	R/ $\overline{W}$ Hold after $\overline{DS}$ Rising	3	—	—	ns
tRWS	R/ $\overline{W}$ Setup from $\overline{DS}$ Falling	3	—	—	ns
tSWD	Valid Data Delay on Write	2	—	—	ns

**NOTES:**

1.  $C_L = 30\text{pF}$
2.  $R_L = 1\text{K}$
3. High-Impedance is measured by pulling to the appropriate rail with  $R_L$ , with timing corrected to cancel time taken to discharge  $C_L$ .
4. To achieve on clock cycle fast memory access, this setup time, tDSS should be met. Otherwise, worst-case memory access operation is determined by tAKD.

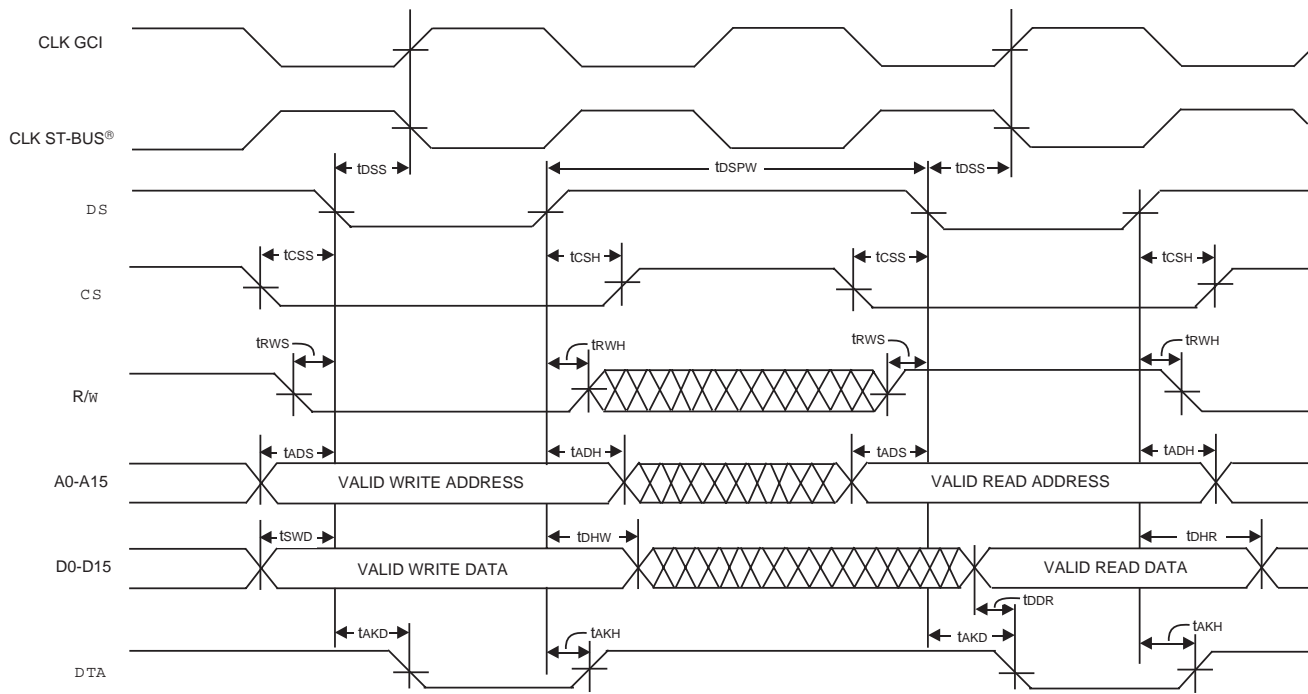

6140 drw17

Figure 20. Motorola Non-Multiplexed Bus Asynchronous Timing Memory Access

### AC ELECTRICAL CHARACTERISTICS - MOTOROLA NON-MULTIPLEXED BUS ASYNCHRONOUS TIMING REGISTER ACCESS

SYMBOL	PARAMETER	MIN.	TYP.	MAX.	UNITS
tADH	Address Hold after $\overline{DS}$ Rising	2	—	—	ns
tADS	Address Setup from $\overline{DS}$ Falling	2	—	—	ns
tAKD <sup>(1)</sup>	Acknowledgement Delay: Reading/Writing Registers	—	—	40	ns
tAKH <sup>(1,2,3)</sup>	Acknowledgement Hold Time	—	—	20	ns
tCSH	$\overline{CS}$ Hold after $\overline{DS}$ Rising	0	—	—	ns
tCSS	$\overline{CS}$ Setup from $\overline{DS}$ Falling	0	—	—	ns
tDDR <sup>(1)</sup>	Data Setup from $\overline{DTA}$ LOW on Read	2	—	—	ns
tDHR <sup>(1,2,3)</sup>	Data Hold on Read	10	15	25	ns
tDHW	Data Hold on Write	5	—	—	ns
tDSPW	Data Strobe Pulse Width	6	—	—	ns
tDSW	Data Setup on Write	10	—	—	ns
tRWH	R/ $\overline{W}$ Hold after $\overline{DS}$ Rising	3	—	—	ns
tRWS	R/ $\overline{W}$ Setup from $\overline{DS}$ Falling	3	—	—	ns

**NOTES:**

1.  $C_L = 30\text{pF}$
2.  $R_L = 1\text{K}$
3. High-Impedance is measured by pulling to the appropriate rail with  $R_L$ , with timing corrected to cancel time taken to discharge  $C_L$ .
4. To achieve on clock cycle fast memory access, this setup time, tDSS should be met. Otherwise, worst-case memory access operation is determined by tAKD.

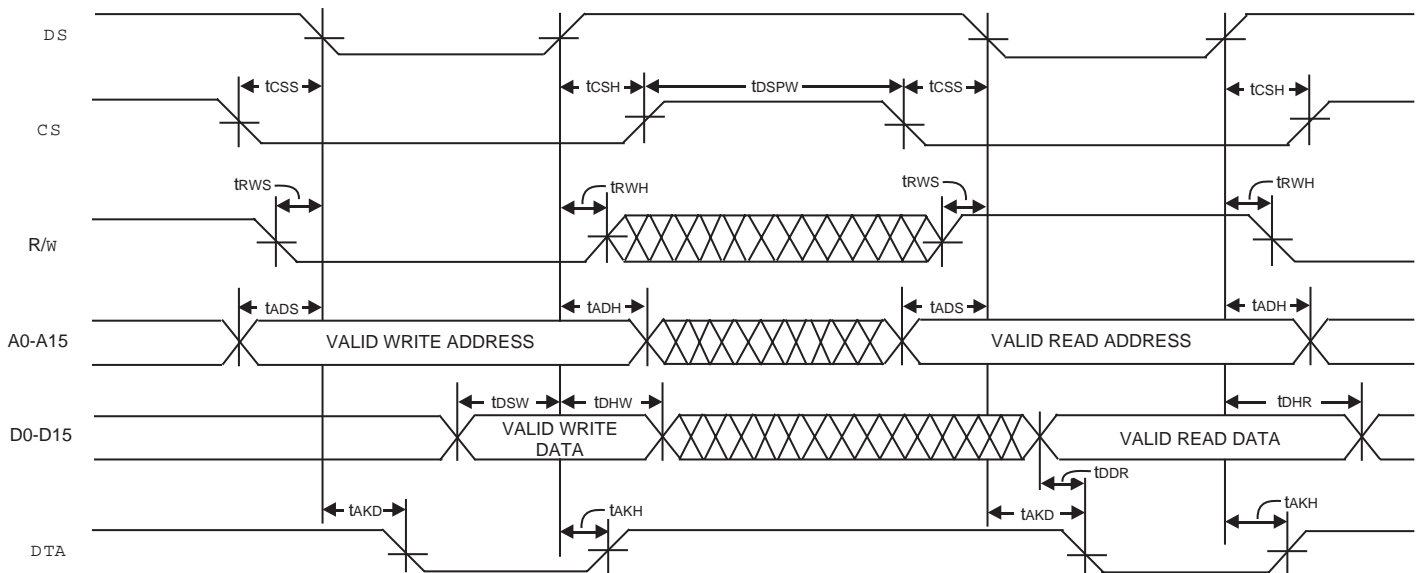

6140 drw17a

Figure 21. Motorola Non-Multiplexed Bus Asynchronous Timing Register Access

### AC ELECTRICAL CHARACTERISTICS - SYNCHRONOUS BUS TIMING

SYMBOL	PARAMETER	MIN.	TYP.	MAX.	UNITS
tADH	Address Hold	3	—	—	ns
tADS	Address Setup	3	—	—	ns
tBEH	Byte Enable Hold	3	—	—	ns
tBES	Byte Enable Setup	3	—	—	ns
tCD	Clock to Data	—	—	20	ns
tDHR <sup>(1,2,3)</sup>	Data Hold on Read	10	15	25	ns
tDHW	Data Hold on Write	3	—	—	ns
tDSW	Data Setup on Write	3	—	—	ns
tRWH	R/W Hold	3	—	—	ns
tRWS	R/W Setup	3	—	—	ns
tSCSH	$\overline{CS}$ Hold	3	—	—	ns
tSCSS	$\overline{CS}$ Setup	3	—	—	ns

**NOTES:**

1.  $C_L = 30\text{pF}$
2.  $R_L = 1\text{K}$
3. High-Impedance is measured by pulling to the appropriate rail with  $R_L$ , with timing corrected to cancel time taken to discharge  $C_L$ .

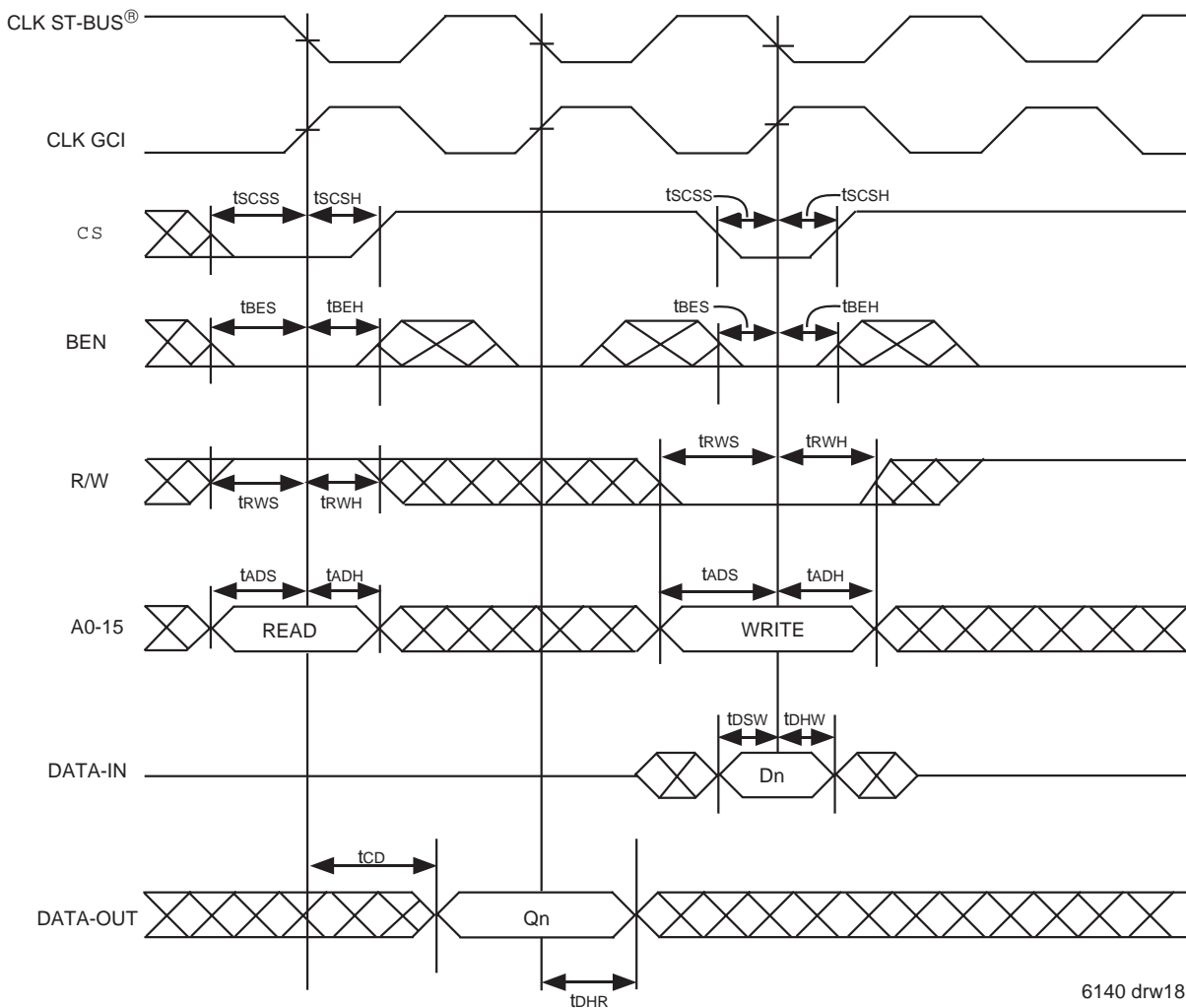

6140 drw18

Figure 22. Synchronous Bus Timing

**AC ELECTRICAL CHARACTERISTICS - BYTE ENABLE**

SYMBOL	PARAMETER	MIN.	TYP.	MAX.	UNITS
tADH	Address Hold	3	—	—	ns
tADS	Address Setup	3	—	—	ns
tBEH	Byte Enable Hold	3	—	—	ns
tBES	Byte Enable Setup	3	—	—	ns
tCD	Clock to Data	—	—	20	ns
tDHR <sup>(1,2,3)</sup>	Data Hold on Read	10	15	25	ns
tRWH	R/W Hold	3	—	—	ns
tRWS	R/W Setup	3	—	—	ns
tSCSH	$\overline{CS}$ Hold	3	—	—	ns
tSCSS	$\overline{CS}$ Setup	3	—	—	ns

**NOTES:**

1.  $C_L = 30\text{pF}$
2.  $R_L = 1\text{K}$
3. High-Impedance is measured by pulling to the appropriate rail with  $R_L$ , with timing corrected to cancel time taken to discharge  $C_L$ .

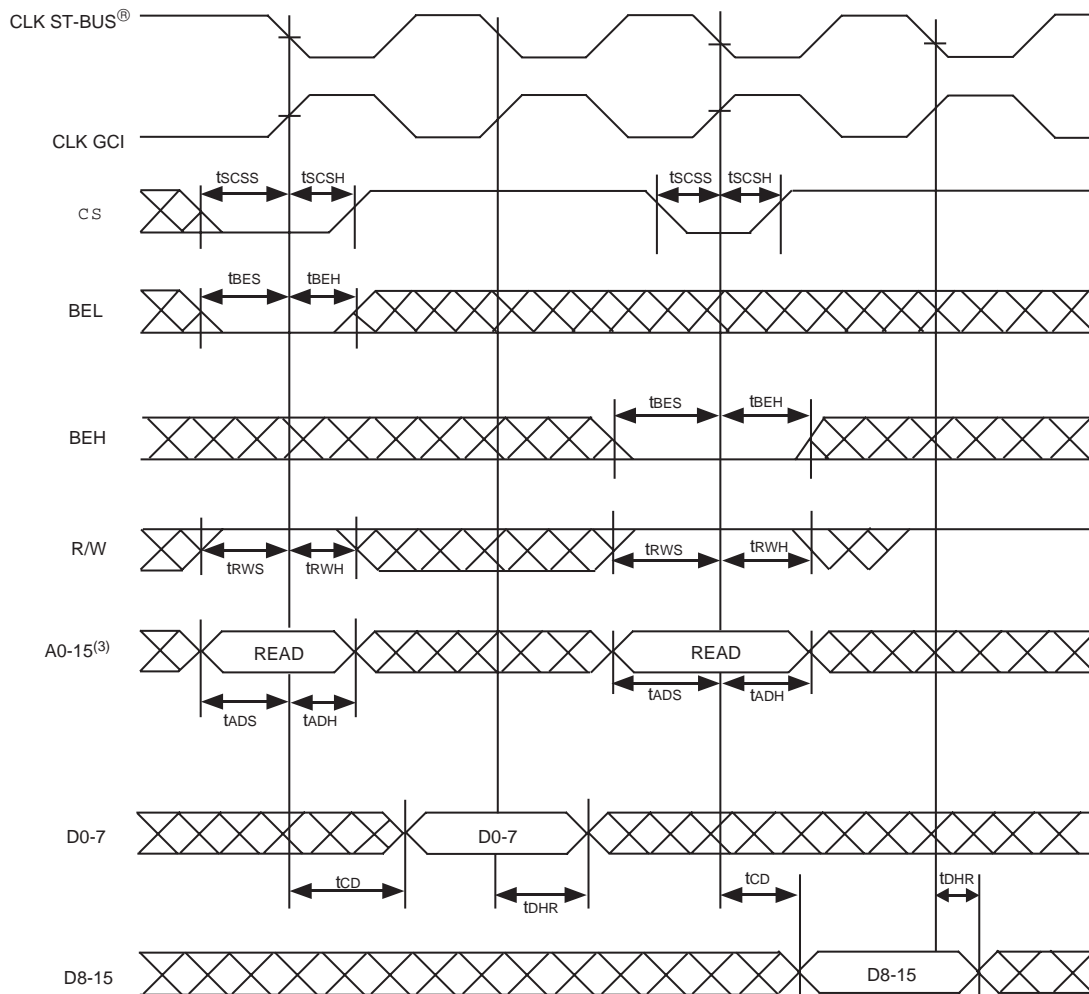

6140 drw19

Figure 23. Byte Enable

## ORDERING INFORMATION

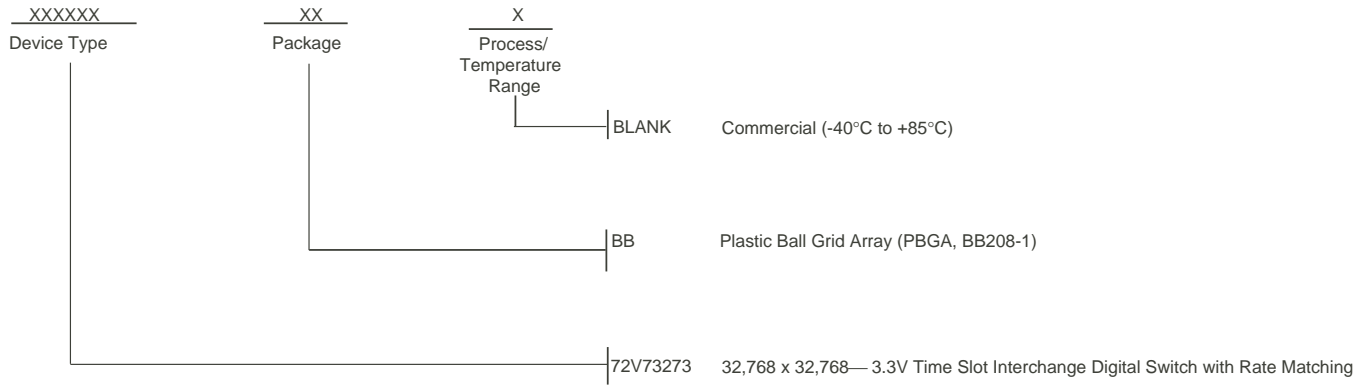

6140 drw22

## DATASHEET DOCUMENT HISTORY

06/30/2003	pgs. 9, 14, 33 and 34.
09/08/2003	pgs. 1, 4, 20, 28, 33 and 34.
10/28/2003	pg. 1.
02/09/2009	pg. 36 removed IDT from orderable part number



**CORPORATE HEADQUARTERS**  
2975 Stender Way  
Santa Clara, CA 95054

**for SALES:**  
800-345-7015 or 408-727-6116  
fax: 408-492-8674  
www.idt.com

**for Tech Support:**  
408-330-1753  
email: TELECOMhelp@idt.com

## Looking for pricing, stock, or lifecycle information?

Click below to explore more details on WIN SOURCE:

- ⊖ [View IDT72V73273BBG on WIN SOURCE](#)
- ⊖ [IDT, Integrated Device Technology Inc Information](#)

## Optimize Your Supply Chain with WIN SOURCE Solutions

- ✓ Global Sourcing Solution
- ✓ Obsolete Management
- ✓ Cost Control Management
- ✓ Shortage Management
- ✓ Alternative Solution
- ✓ Excess Inventory Management